

MECHANICAL DATA

Dimensions in mm (inches)

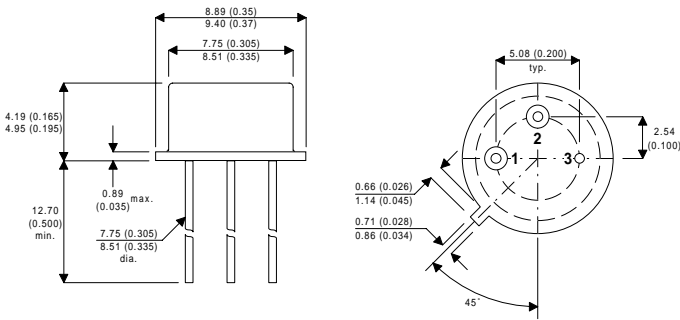

TO-39

Pin 1 – Emitter Pin 2 – Base Pin 3 – Collector

**HIGH SPEED
MEDIUM VOLTAGE
SWITCH**

DESCRIPTION

The 2N4033 is a silicon epitaxial planar PNP transistors in jedec TO-39 metal case intended for use in switching applications.

ABSOLUTE MAXIMUM RATINGS $T_{case} = 25^{\circ}C$ unless otherwise stated

V_{CEO}	Collector – Emitter Voltage	-80V
V_{CBO}	Collector – Base Voltage	-80V
V_{EBO}	Emitter – Base Voltage	-5V
I_C	Continuous Collector Current	-1A
P_D	Total Device Dissipation at $T_A = 25^{\circ}C$	0.8W
	Derate above $25^{\circ}C$	4.56 mW/ $^{\circ}C$
P_D	Total Device Dissipation at $T_C = 25^{\circ}C$	4W
	Derate above $25^{\circ}C$	22.8mW/ $^{\circ}C$
T_{stg}	Operating and Storage Temperature Range	-65 to +200 $^{\circ}C$

THERMAL CHARACTERISTICS

$R_{thj-case}$	Thermal Resistance Junction-case	Max	25	°C/W
$R_{thj-amb}$	Thermal Resistance Junction-ambient	Max	140	°C/W

ELECTRICAL CHARACTERISTICS ($T_{case} = 25^{\circ}C$ unless otherwise stated)

Parameter	Test Conditions	Min.	Typ.	Max.	Unit		
I_{CBO}	Collector Cut Off Current			-50	nA		
	$V_{CB} = -60V$ $T_A = 150^{\circ}C$			-50	μA		
I_{EBO}	Emitter Cut Off Current			-10	μA		
	$V_{EB} = -5V$						
$V_{CE(sat)}$	Collector Emitter Saturation Voltage ¹			-0.15	V		
	$I_C = -150mA$ $I_B = -15mA$						
	$I_C = -500mA$ $I_B = -50mA$			0.50			
$V_{BE(sat)}$	Base Emitter Saturation Voltage ¹			-0.9	V		
	$I_C = -150mA$ $I_B = -15mA$						
$V_{BE(on)}$	Base Emitter on Voltage			-1.1	V		
	$I_C = -500mA$ $V_{CE} = -0.5V^1$						
$V_{(BR)CEO}$	Collector Emitter Breakdown Voltage	-80			V		
	$I_C = -10mA$						
$V_{(BR)CBO}$	Collector Base Breakdown Voltage	-80			V		
	$I_C = -10\mu A$						
$V_{(BR)EBO}$	Emitter Base Breakdown Voltage	-5.0			V		
	$I_E = -10\mu A$						
h_{FE}	DC Current Gain	$I_C = -100mA$ $V_{CE} = -5.0V$ @-55°C ¹			40	—	
		$I_C = -100\mu A$ $V_{CE} = -5.0V$			75		
		$I_C = -100mA$ $V_{CE} = -5.0V^1$			100		300
		$I_C = -500mA$ $V_{CE} = -5.0V^1$			70		
		$I_C = -1.0A$ $V_{CE} = -5.0V^1$			25		

SMALL SIGNAL CHARACTERISTICS

C_{obo}	Output Capacitance	$V_{CE} = -10V$ $f = 1MHz$			20	pF
C_{ibo}	Input Capacitance	$V_{EB} = -0.5V$ $f = 1MHz$			110	
h_{fe}	Small Signal Gain	$I_C = -50mA$ $V_{CE} = -10V$ $f = 100MHz$	1.5		5.0	—

SWITCHING CHARACTERISTICS

t_{on}	Turn On Time	$I_C = -500mA$ $I_{B1} = -I_{B2} = -50mA$			100	ns
t_f	Fall Time				50	
t_s	Storage Time				350	

¹Pulse test $t_p = 300\mu s$, $\delta = 1\%$