

## Silicon PNP Power Transistors

## 2N5954 2N5955 2N5956

## DESCRIPTION

- With TO-66 package
- Low collector-emitter saturation voltage
- Excellent safe operating area
- Complement to type 2N6372 2N6373 2N6374

## APPLICATIONS

- Designed for driver circuits, switching and amplifier applications

## PINNING

PIN	DESCRIPTION
1	Base
2	Emitter
3	Collector

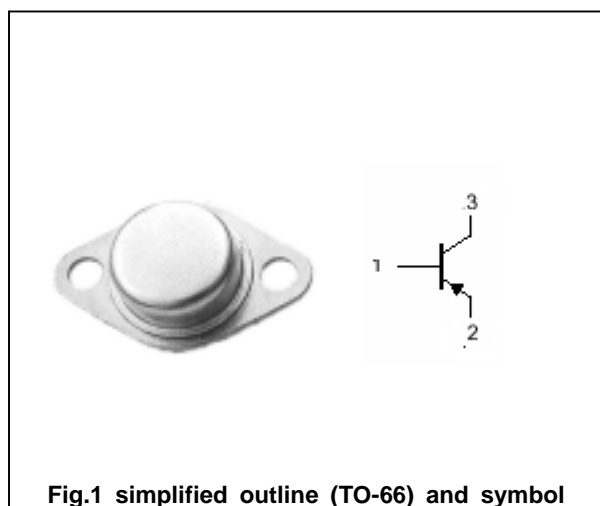

Fig.1 simplified outline (TO-66) and symbol

Absolute maximum ratings( $T_a =$ )

SYMBOL	PARAMETER	CONDITIONS	VALUE	UNIT
$V_{CBO}$	Collector-base voltage	2N5954	90	V
		2N5955	70	
		2N5956	50	
$V_{CEO}$	Collector-emitter voltage	2N5954	80	V
		2N5955	60	
		2N5956	40	
$V_{EBO}$	Emitter-base voltage	Open collector	5	V
$I_C$	Collector current		6	A
$I_B$	Base current		2	A
$P_D$	Total Power Dissipation	$T_C=25$	40	W
$T_j$	Junction temperature		150	
$T_{stg}$	Storage temperature		-65~200	

## THERMAL CHARACTERISTICS

SYMBOL	PARAMETER	VALUE	UNIT
$R_{th-j-c}$	Thermal resistance junction to case	4.3	/W

## Silicon PNP Power Transistors

## 2N5954 2N5955 2N5956

## CHARACTERISTICS

T<sub>j</sub>=25 unless otherwise specified

SYMBOL	PARAMETER	CONDITIONS	MIN	TYP.	MAX	UNIT
V <sub>CEO(sus)</sub>	Collector-emitter sustaining voltage	2N5954	80			V
		2N5955	60			
		2N5956	40			
V <sub>CEsat</sub>	Collector-emitter saturation voltage	2N5954			1.0	V
		2N5955				
		2N5956				
V <sub>BE-1</sub>	Base-emitter on voltage	2N5954			2.0	V
		2N5955				
		2N5956				
V <sub>BE-2</sub>	Base-emitter on voltage	I <sub>C</sub> =6A ; V <sub>CE</sub> =4V			3.0	V
I <sub>CEO</sub>	Collector cut-off current	2N5954			1.0	mA
		2N5955				
		2N5956				
I <sub>CEV</sub>	Collector cut-off current(R <sub>BE</sub> =100 )	V <sub>CE</sub> =Rated V <sub>CE</sub> ; V <sub>BE(off)</sub> =1.5V T <sub>C</sub> =150			0.1 2.0	mA
I <sub>EBO</sub>	Emitter cut-off current	V <sub>EB</sub> =5V; I <sub>C</sub> =0			0.1	mA
h <sub>FE-1</sub>	DC current gain	2N5954		20	100	
		2N5955				
		2N5956				
h <sub>FE-2</sub>	DC current gain	I <sub>C</sub> =6A ; V <sub>CE</sub> =4V	5			
f <sub>T</sub>	Transition frequency	I <sub>C</sub> =1A;V <sub>CE</sub> =4V;f=1.0MHz	5			MHz

Silicon PNP Power Transistors

2N5954 2N5955 2N5956

PACKAGE OUTLINE

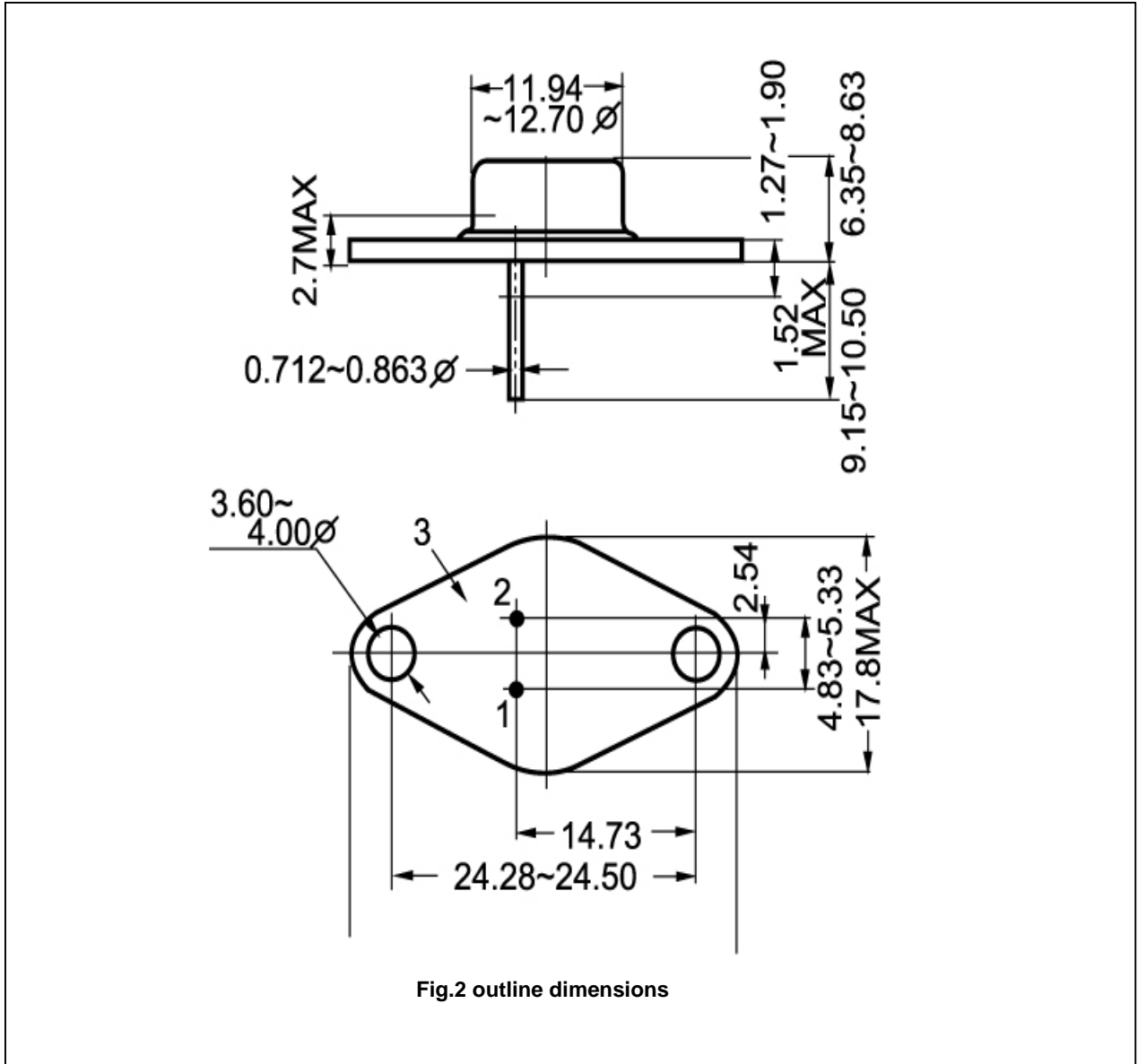

Fig.2 outline dimensions