

2 Amps, 600/650 Volts N-CHANNEL MOSFET

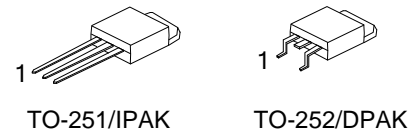
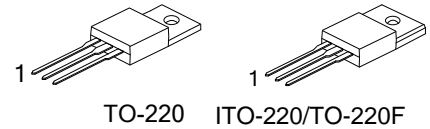

DESCRIPTION

2N60 2N65 is a high voltage MOSFET and is designed to have better characteristics, such as fast switching time, low gate charge, low on-state resistance and have a high rugged avalanche characteristics. This power MOSFET is usually used at high speed switching applications in power supplies, PWM motor controls, high efficient DC to DC converters and bridge circuits.

FEATURES

- * $R_{DS(ON)} = 5\Omega @ V_{GS} = 10V$
- * Ultra Low gate charge (typical 9.0nC)
- * Low reverse transfer capacitance ($C_{RSS} =$ typical 5.0 pF)
- * Fast switching capability
- * Avalanche energy specified
- * Improved dv/dt capability, high ruggedness

SYMBOL

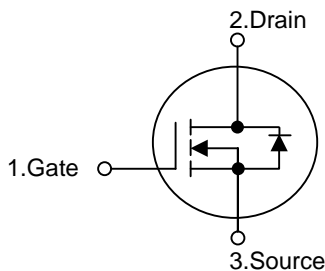

ORDERING INFORMATION

Ordering Number	Package	Pin Assignment		
		1	2	3
2N60	TO-220	G	D	S
	ITO-220/TO-220F	G	D	S
2N65	TO-251/IPAK	G	D	S
	TO-252/DPAK	G	D	S

Note: Pin Assignment: G: Gate D: Drain S: Source

Part No.	Package	Packing
2N6*-TU	TO-251	75pcs / Tube
2N6*-TR	TO-252	2.5Kpcs / 13" Reel
2N6*-TU	TO-252	75pcs / Tube
2N6*-TU	TO-220	50pcs / Tube
2N6*-TU	ITO-220/TO-220F	50pcs / Tube
2N6*-TU	TO-262	50pcs / Tube
2N6*-TU	TO-263	50pcs / Tube
2N6*-TR	TO-263	800pcs / 13" Reel

■ ABSOLUTE MAXIMUM RATINGS ($T_C = 25^\circ\text{C}$, unless otherwise specified)

PARAMETER		SYMBOL	RATINGS	UNIT
Drain-Source Voltage	2N60	V_{DSS}	600	V
	2N65		650	V
Gate-Source Voltage		V_{GSS}	± 30	V
Avalanche Current (Note 2)		I_{AR}	2.0	A
Drain Current	Continuous	I_D	2.0	A
	Pulsed (Note 2)	I_{DM}	8.0	A
Avalanche Energy	Single Pulsed (Note 3)	E_{AS}	140	mJ
	Repetitive (Note 2)	E_{AR}	4.5	mJ
Peak Diode Recovery dv/dt (Note 4)		dv/dt	4.5	V/ns
Power Dissipation	TO-220	P_D ($T_C = 25^\circ\text{C}$)	54	W
	TO-220F		23	W
	TO-251/IPAK		44	W
	TO-252/DPAK		44	W
Junction Temperature		T_J	+150	$^\circ\text{C}$
Ambient Operating Temperature		T_{OPR}	-55 ~ +150	$^\circ\text{C}$
Storage Temperature		T_{STG}	-55 ~ +150	$^\circ\text{C}$

Notes: 1. Absolute maximum ratings are those values beyond which the device could be permanently damaged.

Absolute maximum ratings are stress ratings only and functional device operation is not implied.

2. Repetitive Rating : Pulse width limited by T_J

3. $L=64\text{mH}$, $I_{AS}=2.0\text{A}$, $V_{DD}=50\text{V}$, $R_G=25\ \Omega$, Starting $T_J = 25^\circ\text{C}$

4. $I_{SD} \leq 2.0\text{A}$, $di/dt \leq 200\text{A}/\mu\text{s}$, $V_{DD} \leq BV_{DSS}$, Starting $T_J = 25^\circ\text{C}$

■ THERMAL DATA

PARAMETER		SYMBOL	RATINGS	UNIT
Junction-to-Ambient	TO-251/IPAK	θ_{JA}	100	$^\circ\text{C}/\text{W}$
	TO-252/DPAK		100	
	TO-220		62.5	
	TO-220F		62.5	
Junction-to-Case	TO-251/IPAK	θ_{JC}	2.87	$^\circ\text{C}/\text{W}$
	TO-252/DPAK		2.87	
	TO-220		2.32	
	TO-220F		5.50	

■ ELECTRICAL CHARACTERISTICS ($T_J=25^\circ\text{C}$, unless otherwise specified)

PARAMETER	SYMBOL	TEST CONDITIONS	MIN	TYP	MAX	UNIT
OFF CHARACTERISTICS						
Drain-Source Breakdown Voltage	2N60	$V_{GS} = 0V, I_D = 250\mu A$	600			V
	2N65		650			V
Drain-Source Leakage Current	I_{DSS}	$V_{DS} = 600V, V_{GS} = 0V$			10	μA
Gate-Source Leakage Current	Forward	$V_{GS} = 30V, V_{DS} = 0V$ $V_{GS} = -30V, V_{DS} = 0V$			100	nA
	Reverse				-100	nA
Breakdown Voltage Temperature Coefficient	$\Delta BV_{DSS}/\Delta T_J$	$I_D = 250 \mu A$, Referenced to 25°C		0.4		$^\circ\text{C}^{-1}$
ON CHARACTERISTICS						
Gate Threshold Voltage	$V_{GS(TH)}$	$V_{DS} = V_{GS}, I_D = 250\mu A$	2.0		4.0	V
Static Drain-Source On-State Resistance	$R_{DS(ON)}$	$V_{GS} = 10V, I_D = 1A$		3.8	5	Ω
DYNAMIC CHARACTERISTICS						
Input Capacitance	C_{ISS}	$V_{DS} = 25V, V_{GS} = 0V, f = 1\text{MHz}$		270	350	pF
Output Capacitance	C_{OSS}		40	50	pF	
Reverse Transfer Capacitance	C_{RSS}		5	7	pF	
SWITCHING CHARACTERISTICS						
Turn-On Delay Time	$t_{D(ON)}$	$V_{DD} = 300V, I_D = 2.0A,$ $R_G = 25\Omega$ (Note 1, 2)		10	30	ns
Turn-On Rise Time	t_R		25	60	ns	
Turn-Off Delay Time	$t_{D(OFF)}$		20	50	ns	
Turn-Off Fall Time	t_F		25	60	ns	
Total Gate Charge	Q_G	$V_{DS} = 480V, V_{GS} = 10V,$ $I_D = 2.0A$ (Note 1, 2)		9.0	11	nC
Gate-Source Charge	Q_{GS}		1.6		nC	
Gate-Drain Charge	Q_{GD}		4.3		nC	
DRAIN-SOURCE DIODE CHARACTERISTICS						
Drain-Source Diode Forward Voltage	V_{SD}	$V_{GS} = 0V, I_{SD} = 2.0A$			1.4	V
Continuous Drain-Source Current	I_{SD}				2.0	A
Pulsed Drain-Source Current	I_{SM}				8.0	A
Reverse Recovery Time	t_{RR}	$V_{GS} = 0V, I_{SD} = 2.0A,$ $di/dt = 100 A/\mu s$ (Note1)		180		ns
Reverse Recovery Charge	Q_{RR}		0.72		μC	

Notes: 1. Pulse Test: Pulse width $\leq 300\mu s$, Duty cycle $\leq 2\%$
2. Essentially independent of operating temperature

■ TEST CIRCUITS AND WAVEFORMS

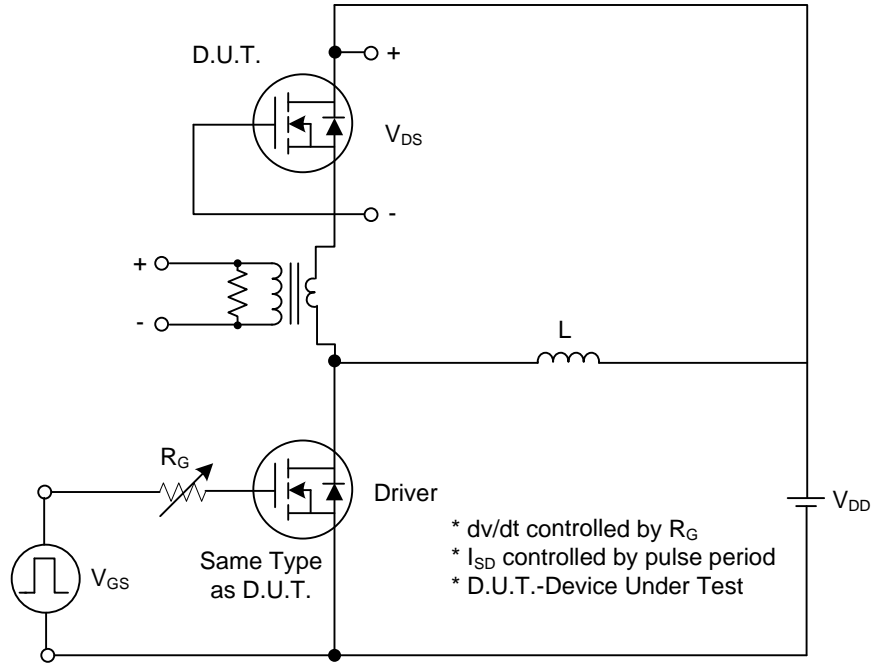

Fig. 1A Peak Diode Recovery dv/dt Test Circuit

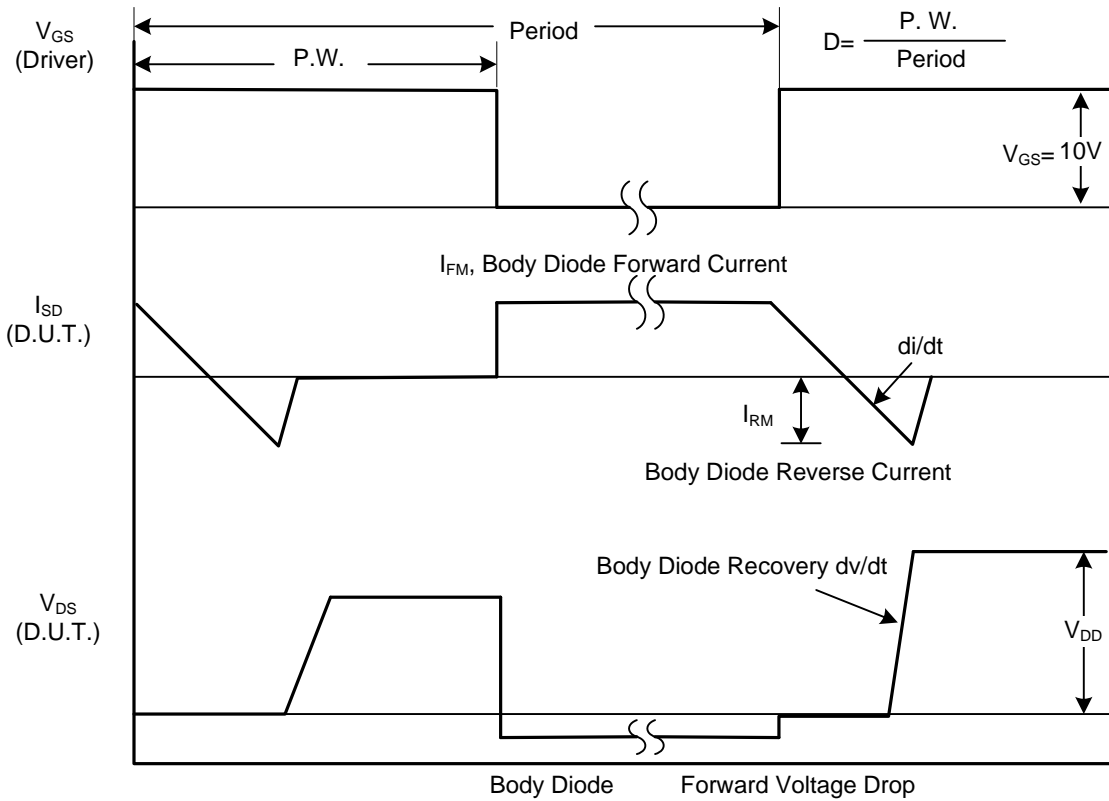

Fig. 1B Peak Diode Recovery dv/dt Waveforms

■ TEST CIRCUITS AND WAVEFORMS (Cont.)

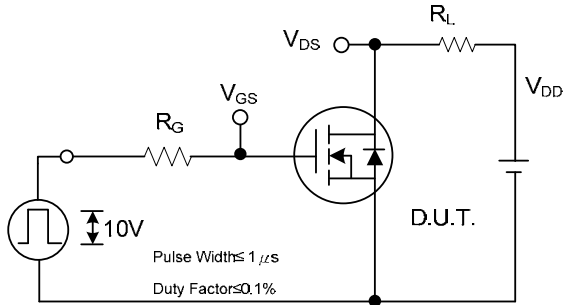

Fig. 2A Switching Test Circuit

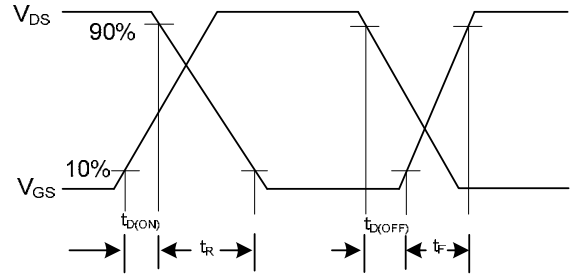

Fig. 2B Switching Waveforms

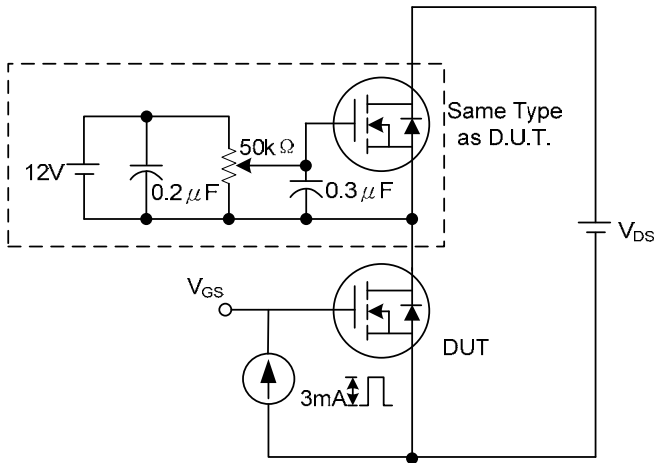

Fig. 3A Gate Charge Test Circuit

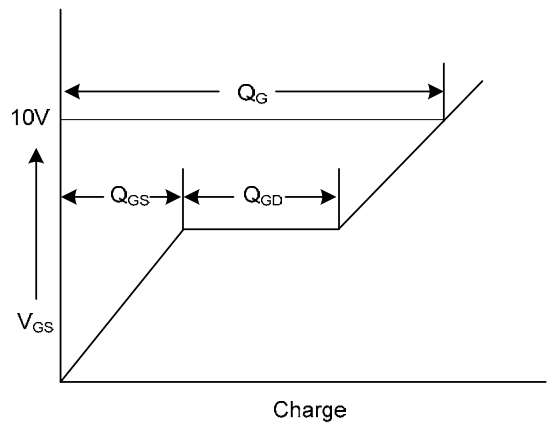

Fig. 3B Gate Charge Waveform

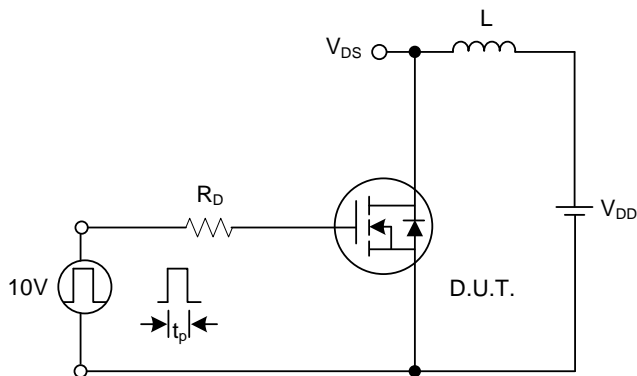

Fig. 4A Unclamped Inductive Switching Test Circuit

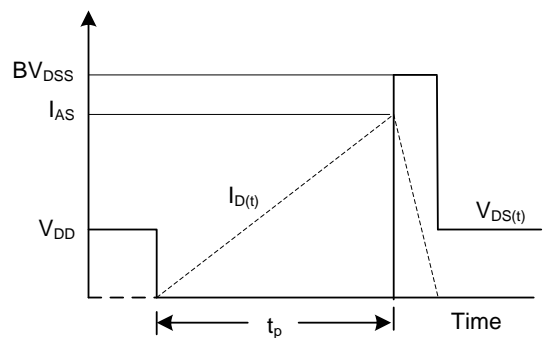

Fig. 4B Unclamped Inductive Switching Waveforms

■ TYPICAL CHARACTERISTICS

