

Silicon NPN Power Transistors

2N6077 2N6078 2N6079

DESCRIPTION

- With TO-66 package
- Low collector saturation voltage
- High breakdown voltage

APPLICATIONS

- For horizontal deflection output stages of TV's and CRT's

PINNING

PIN	DESCRIPTION
1	Base
2	Emitter
3	Collector

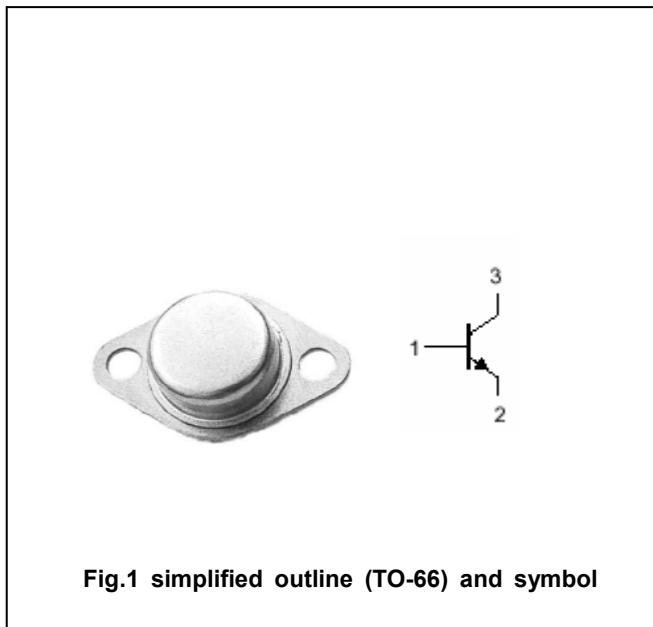

Absolute maximum ratings(Ta=□)

SYMBOL	PARAMETER	CONDITIONS	VALUE	UNIT
V _{CBO}	Collector-base voltage	2N6077	300	V
		2N6078	275	
		2N6079	375	
V _{CEO}	Collector-emitter voltage	2N6077	275	V
		2N6078	250	
		2N6079	350	
V _{EBO}	Emitter-base voltage	Open collector	6	V
I _C	Collector current		7	A
P _D	Total Power Dissipation	T _C =25□	45	W
T _j	Junction temperature		150	□
T _{stg}	Storage temperature		-65~200	□

THERMAL CHARACTERISTICS

SYMBOL	PARAMETER	VALUE	UNIT
R _{th j-c}	Thermal resistance junction to case	4.28	□/W

Silicon NPN Power Transistors

2N6077 2N6078 2N6079

CHARACTERISTICS

T_j=25°C unless otherwise specified

SYMBOL	PARAMETER	CONDITIONS	MIN	TYP.	MAX	UNIT
V _{CEO(SUS)}	Collector-emitter sustaining voltage	2N6077	275			V
		2N6078	250			
		2N6079	350			
		I _C =0.1A ; I _B =0				
V _{CEsat}	Collector-emitter saturation voltage	I _C =5A; I _B =0.5A			1.0	V
V _{BEsat}	Base-emitter saturation voltage	I _C =5A; I _B =0.5A			1.2	V
I _{CEO}	Collector cut-off current	V _{CE} = Rated V _{CEO} ; I _B =0			2.0	mA
I _{CEX}	Collector cut-off current	V _{CE} =Rated V _{CEO} ; V _{BE(off)} =1.5V T _C =125°C			0.1 1.0	mA
I _{CBO}	Collector cut-off current	V _{CB} =Rated V _{CBO} ; I _E =0			0.1	mA
I _{EBO}	Emitter cut-off current	V _{EB} =6V; I _C =0			1.0	mA
h _{FE}	DC current gain	I _C =1.2A ; V _{CE} =1V	12		70	
f _T	Transition frequency	I _C =0.5A; V _{CE} =10V; f=1MHz		7		MHz

Silicon NPN Power Transistors

2N6077 2N6078 2N6079

PACKAGE OUTLINE

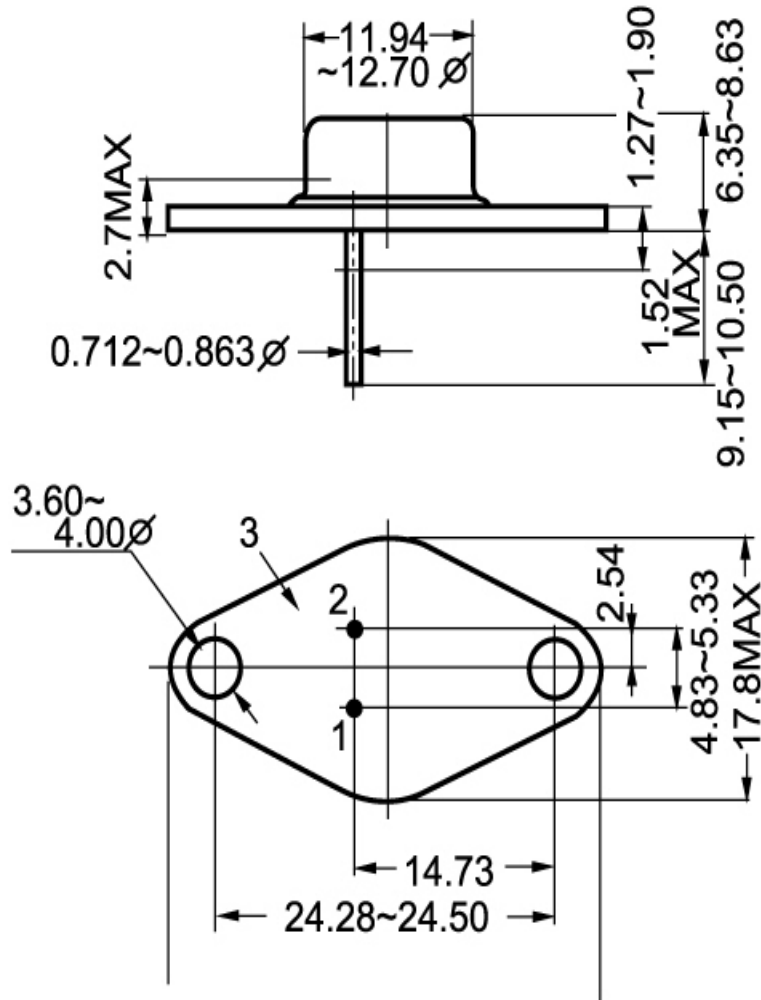

Fig.2 outline dimensions