

## Silicon Planar Epitaxial Transistor

2SA1213

### FEATURES

- Low saturation voltage
- High speed switching time
- Small flat package
- $P_C=1.0$  to  $2.0W$ (mounted on ceramic substrate)
- Complementary to 2SC2873

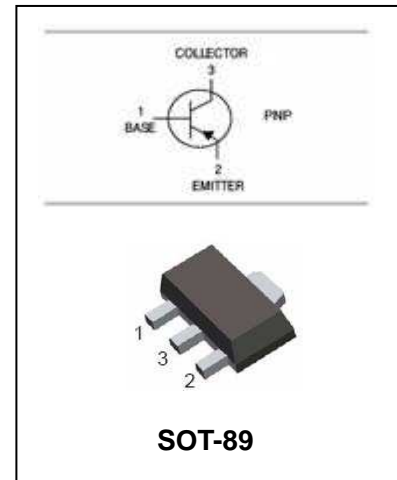

### ORDERING INFORMATION

Type No.	Marking	Package Code
2SA1213	NO/NY	SOT-89

### MAXIMUM RATING @ $T_a=25^{\circ}C$ unless otherwise specified

Symbol	Parameter	Value	Units
$V_{CBO}$	Collector-Base Voltage	-50	V
$V_{CEO}$	Collector-Emitter Voltage	-50	V
$V_{EBO}$	Emitter-Base Voltage	-5	V
$I_C$	Collector Current	-2	A
$I_B$	Base Current	-0.4	A
$P_C$	Collector Dissipation	500 1000(Note1)	mW
$R_{\theta JA}$	Thermal resistance junction to ambient air	75	$^{\circ}C/W$
$R_{\theta JC}$	Junction-case thermal resistance	35	$^{\circ}C/W$
$T_j, T_{stg}$	Junction and Storage Temperature	-55 to +150	$^{\circ}C$

Note1: Mounted on ceramic substrate( $250mm^2 \times 0.8t$ )

Silicon Planar Epitaxial Transistor

2SA1213

ELECTRICAL CHARACTERISTICS @ Ta=25°C unless otherwise specified

Parameter	Symbol	Test conditions	MIN	TYP	MAX	UNIT
Collector-emitter breakdown voltage	$V_{(BR)CEO}$	$I_C=-10mA, I_B=0$	-50			V
Collector cut-off current	$I_{CBO}$	$V_{CB}=-50V, I_E=0$			-0.1	$\mu A$
Emitter cut-off current	$I_{EBO}$	$V_{EB}=-5V, I_C=0$			-0.1	$\mu A$
DC current gain	$h_{FE}$	$V_{CE}=-2V, I_C=-0.5A$	70		240	
		$V_{CE}=-2V, I_C=-2.0A$	20			
Collector-emitter saturation voltage	$V_{CE(sat)}$	$I_C=-1A, I_B=-0.05A$			-0.5	V
Base-emitter saturation voltage	$V_{BE(sat)}$	$I_C=-1A, I_B=-0.05A$			-1.2	V
Transition frequency	$f_T$	$V_{CE}=-2V, I_C=-0.5A$		120		MHz
Collector output capacitance	$C_{ob}$	$V_{CB}=-10V, I_E=0, f=1MHz$		40		pF

CLASSIFICATION OF  $h_{FE}$

Rank	O	Y
Range	70-140	120-240
Marking	NO	NY

Silicon Planar Epitaxial Transistor

2SA1213

TYPICAL CHARACTERISTICS @  $T_a=25^\circ\text{C}$  unless otherwise specified

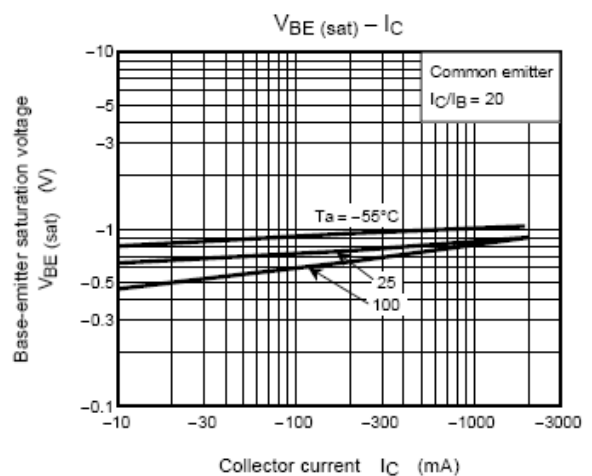
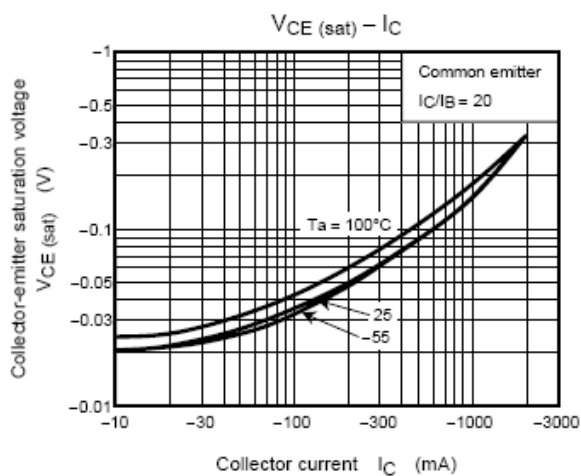
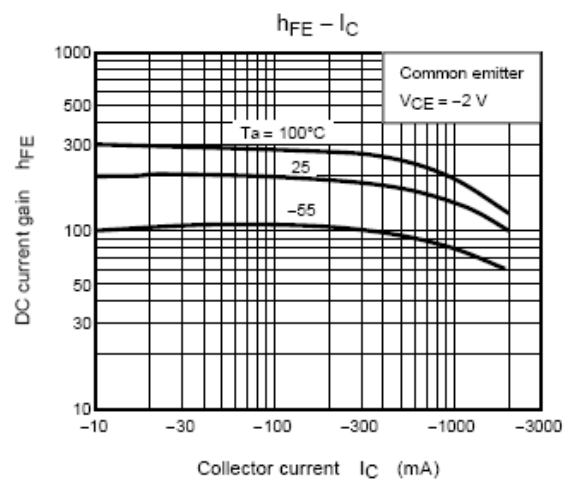
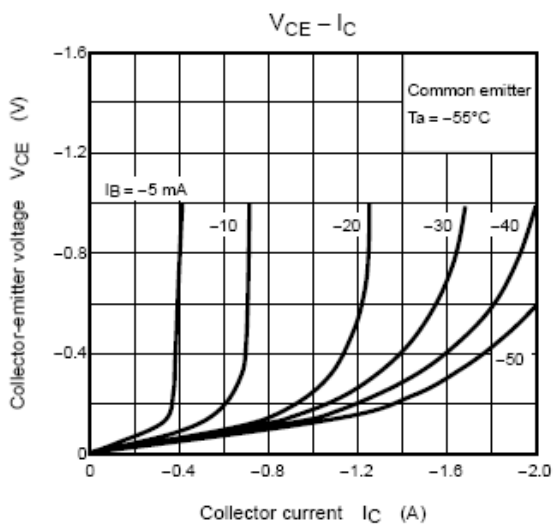
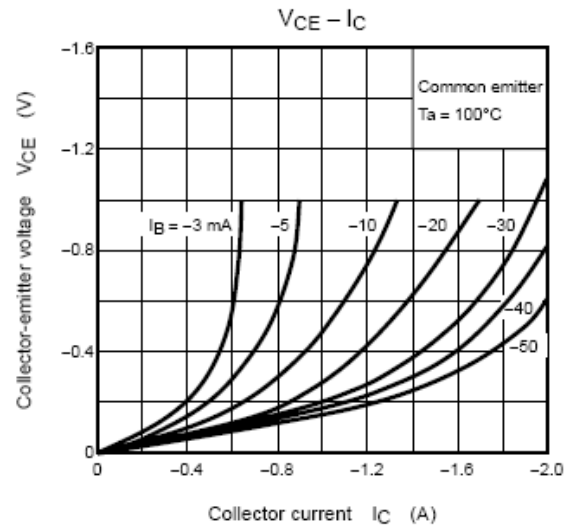
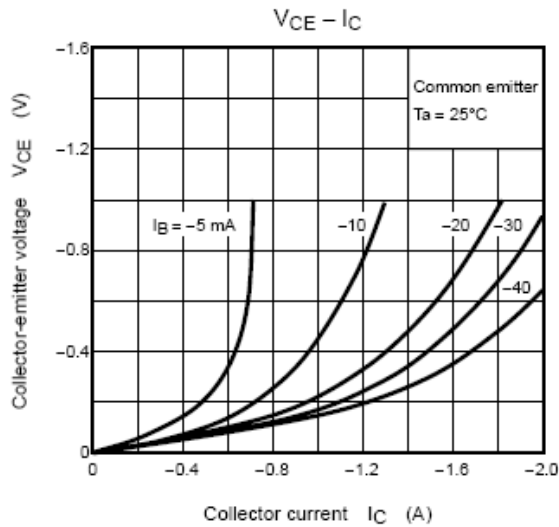

# Silicon Planar Epitaxial Transistor

2SA1213

## PACKAGE OUTLINE

Plastic surface mounted package

SOT-89

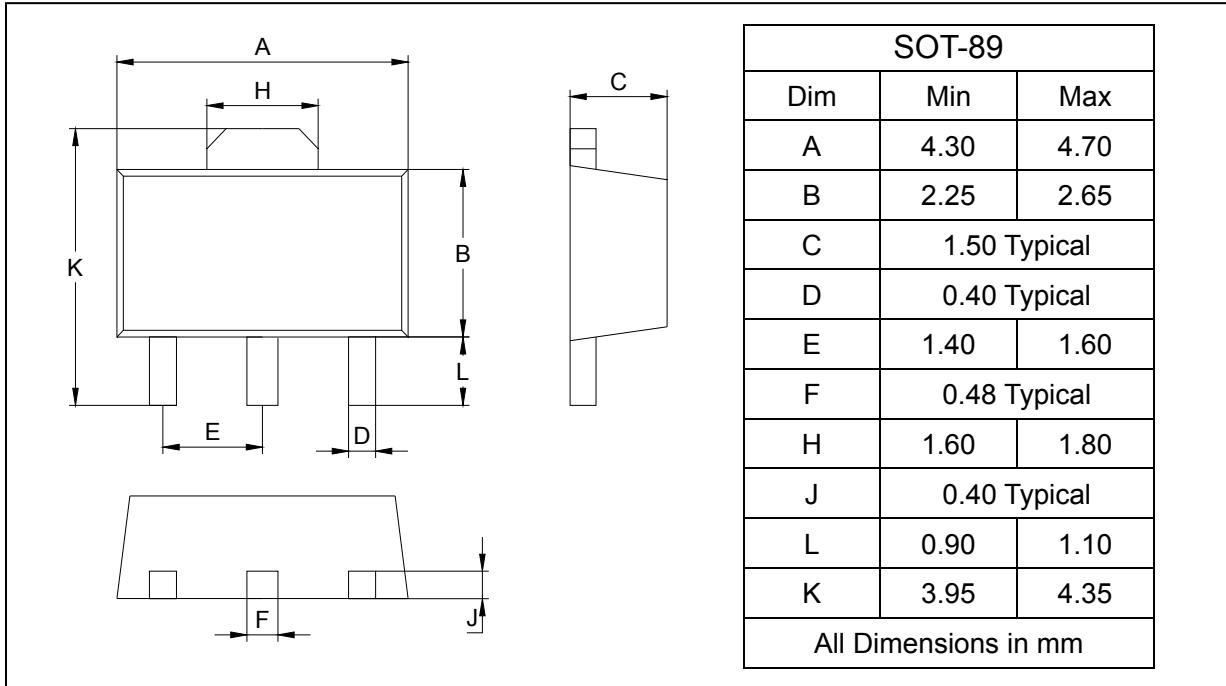

## SOLDERING FOOTPRINT

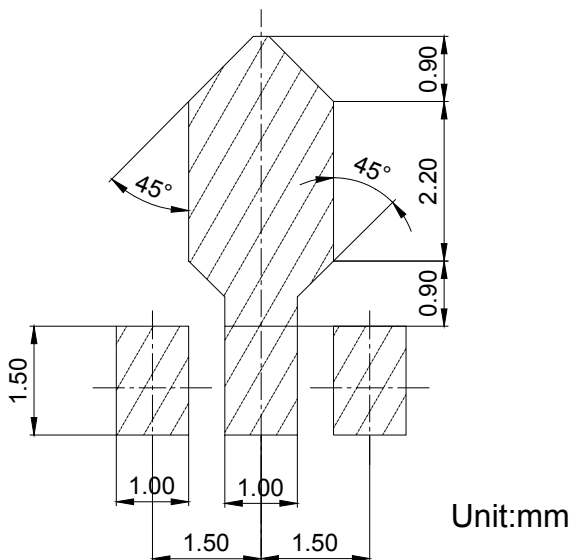

## PACKAGE INFORMATION

Device	Package	Shipping
2SA1213	SOT-89	1000/Tape&Reel