

High-Voltage Switching Applications

2SA1419

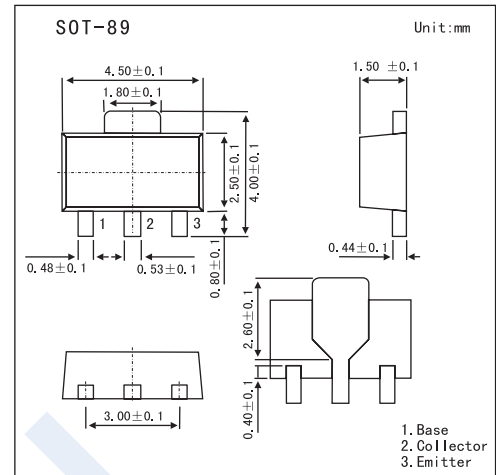

■ Features

- Adoption of FBET, MBIT Processes
- High Breakdown Voltage and Large Current Capacity

■ Absolute Maximum Ratings $T_a = 25^\circ\text{C}$

Parameter	Symbol	Rating	Unit
Collector-Base Voltage	V_{CB0}	-180	V
Collector-Emitter Voltage	V_{CEO}	-160	V
Emitter-Base Voltage	V_{EBO}	-6	V
Collector Current	I_C	-1.5	A
Collector Current (Pulse)	I_{CP}	-2.5	A
Collector Power Dissipation	P_C	500	mW
	P_C^*	1.5	W
Junction temperature	T_j	150	$^\circ\text{C}$
Storage temperature Range	T_{stg}	-55 to +150	$^\circ\text{C}$

* Mounted on ceramic board ($250\text{ mm}^2 \times 0.8\text{ mm}$)

■ Electrical Characteristics $T_a = 25^\circ\text{C}$

Parameter	Symbol	Testconditions	Min	Typ	Max	Unit
Collector Cut-off Current	I_{CBO}	$V_{CB} = -120\text{V}$, $I_E = 0$			-1	μA
Emitter Cut-off Current	I_{EBO}	$V_{EB} = -4\text{V}$, $I_C = 0$			-1	μA
Collector-Base Breakdown Voltage	$V_{(BR)CBO}$	$I_C = -10\mu\text{A}$, $I_E = 0$	-180			V
Collector-Emitter Breakdown Voltage	$V_{(BR)CEO}$	$I_C = -1\text{mA}$, $R_{BE} = \infty$	-160			V
Emitter-Base Breakdown Voltage	$V_{(BR)EBO}$	$I_E = -10\mu\text{A}$, $I_C = 0$	-6			V
DC Current Gain	h_{FE}	$V_{CE} = -5\text{V}$, $I_C = -100\text{mA}$	100		400	
		$V_{CE} = -5\text{V}$, $I_C = -10\text{mA}$	80			
Collector-Emitter Saturation Voltage	$V_{CE(sat)}$	$I_C = -500\text{mA}$, $I_B = -50\text{mA}$		-0.2	-0.5	V
Base-Emitter Saturation Voltage	$V_{BE(sat)}$	$I_C = -500\text{mA}$, $I_B = -50\text{mA}$		-0.85	-1.2	V
Gain-Bandwidth Product	f_T	$V_{CE} = -10\text{V}$, $I_C = -50\text{mA}$		120		MHz
Collector Output Capacitance	C_{ob}	$V_{CB} = -10\text{V}$, $I_E = 0$, $f = 1\text{MHz}$		22		pF
Turn-On Time	t_{on}	See Test Circuit.		40		ns
Storage Time	t_{stg}			0.7		μs
Fall Time	t_f			40		ns

2SA1419

Test Circuit

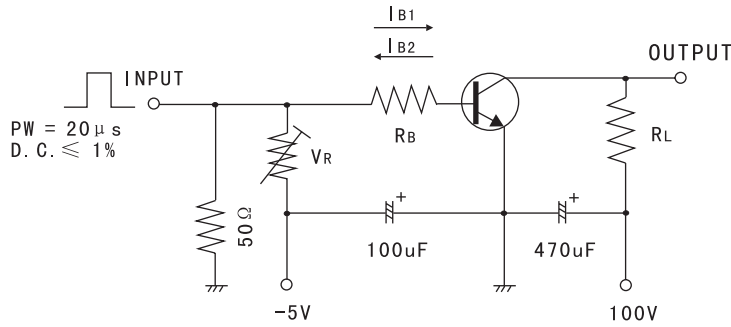

$10I_{B1} = -10I_{B2} = I_C = 0.7A$
 (For PNP, the polarity is reversed.)

hFE Classification

Marking	AE		
Rank	R	S	T
hFE	100 ~ 200	140 ~ 280	200 ~ 400

Electrical Characteristics Curves

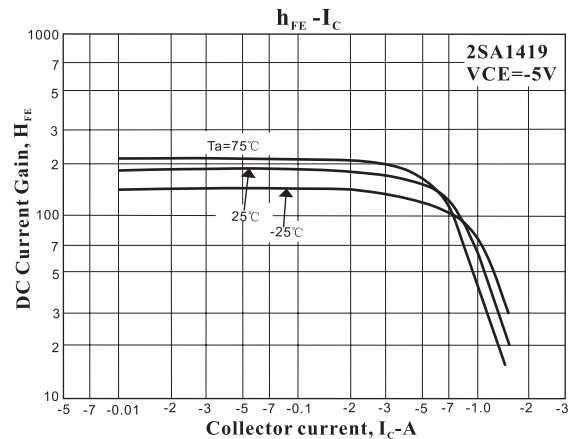
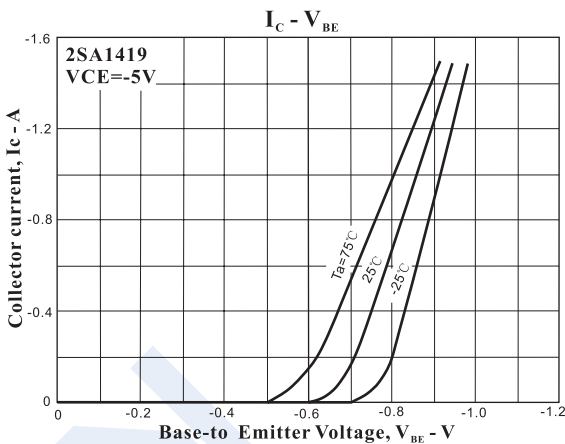
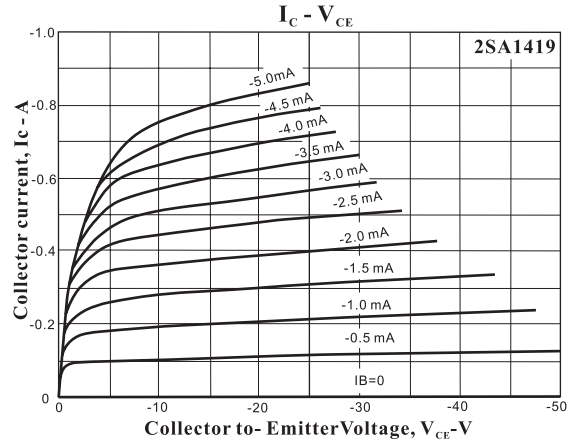
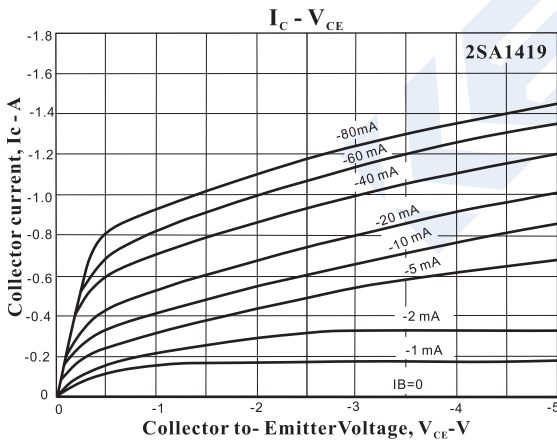

2SA1419

