

isc Silicon PNP Power Transistor

2SA2210

DESCRIPTION

- Large current capacitance
- High-speed switching
- 100% avalanche tested
- Minimum Lot-to-Lot variations for robust device performance and reliable operation

APPLICATIONS

- relay drivers, lamp drivers, motor drivers

ABSOLUTE MAXIMUM RATINGS(T_a=25°C)

SYMBOL	PARAMETER	VALUE	UNIT
V _{CBO}	Collector-Base Voltage	-50	V
V _{CEO}	Collector-Emitter Voltage	-50	V
V _{EBO}	Emitter-Base Voltage	-6	V
I _C	Collector Current-Continuous	-20	A
I _{CM}	Collector Current-Peak	-25	A
P _C	Collector Power Dissipation @ T _C =25°C	30	W
	Collector Power Dissipation @ T _a =25°C	2	
T _J	Junction Temperature	150	°C
T _{stg}	Storage Temperature Range	-55~150	°C

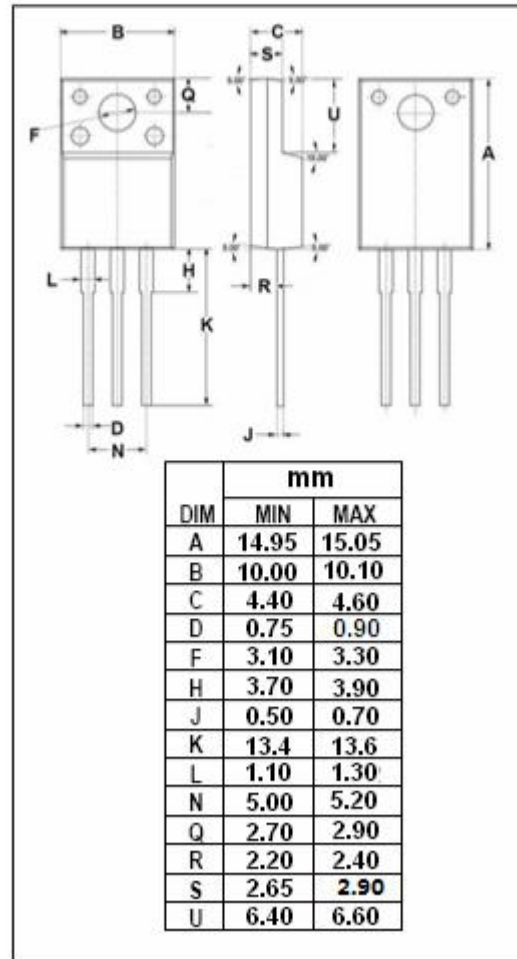
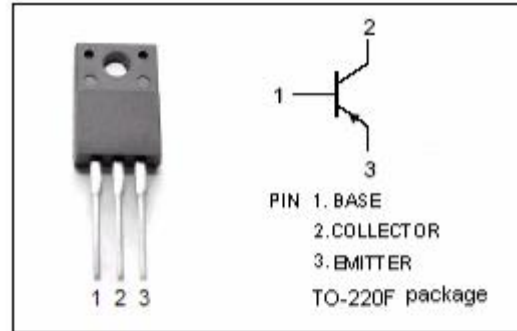

isc Silicon PNP Power Transistor**2SA2210****ELECTRICAL CHARACTERISTICS****T_c=25°C unless otherwise specified**

SYMBOL	PARAMETER	CONDITIONS	MIN	TYP.	MAX	UNIT
V _{CE(sat)}	Collector-Emitter Saturation Voltage	I _C = -7A; I _B = -350mA			-0.5	V
V _{BE(sat)}	Base-Emitter Saturation Voltage	I _C = -7A; I _B = -350mA			-1.2	V
V _{(BR)CEO}	Collector-Emitter Breakdown Voltage	I _C = -1mA; I _B = 0	-50			V
V _{(BR)EBO}	Emitter-Base Breakdown Voltage	I _E = -100uA; I _C = 0	-6			V
I _{CBO}	Collector Cutoff Current	V _{CB} = -40V; I _E = 0			-10	μ A
I _{EBO}	Emitter Cutoff Current	V _{EB} = -4V; I _C = 0			-10	μ A
h _{FE}	DC Current Gain	I _C = -1A; V _{CE} = -2V	200		560	
C _{OB}	Output Capacitance	I _E = 0; V _{CB} = -10V; f= 1.0MHz		215		pF
f _T	Current-Gain—Bandwidth Product	I _C = -1A; V _{CE} = -10V		140		MHz