

isc Silicon PNP Darlington Power Transistor

2SB1253

DESCRIPTION

- High DC Current Gain-
: $h_{FE} = 5000(\text{Min}) @ I_C = -5A$
- Low-Collector Saturation Voltage-
: $V_{CE(\text{sat})} = -2.5V(\text{Max.}) @ I_C = -5A$
- Complement to Type 2SD1893
- Minimum Lot-to-Lot variations for robust device performance and reliable operation

APPLICATIONS

- Designed for power amplifier applications

ABSOLUTE MAXIMUM RATINGS($T_a=25^\circ\text{C}$)

SYMBOL	PARAMETER	VALUE	UNIT
V_{CBO}	Collector-Base Voltage	-130	V
V_{CEO}	Collector-Emitter Voltage	-110	V
V_{EBO}	Emitter-Base Voltage	-5	V
I_C	Collector Current-Continuous	-6	A
I_{CM}	Collector Current-Peak	-10	A
P_C	Collector Power Dissipation @ $T_C=25^\circ\text{C}$	50	W
	Collector Power Dissipation @ $T_a=25^\circ\text{C}$	3	
T_J	Junction Temperature	150	$^\circ\text{C}$
T_{stg}	Storage Temperature Range	-55~150	$^\circ\text{C}$

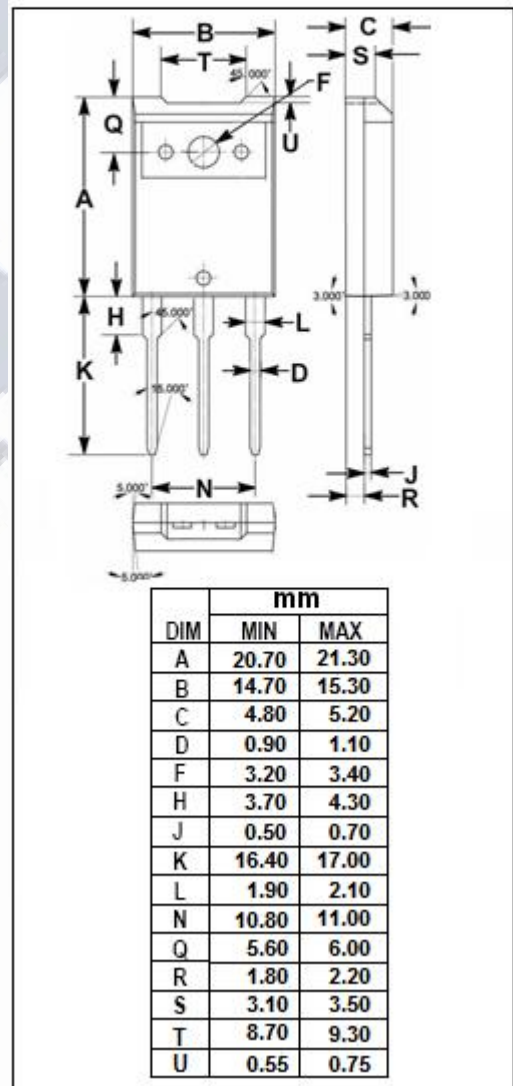
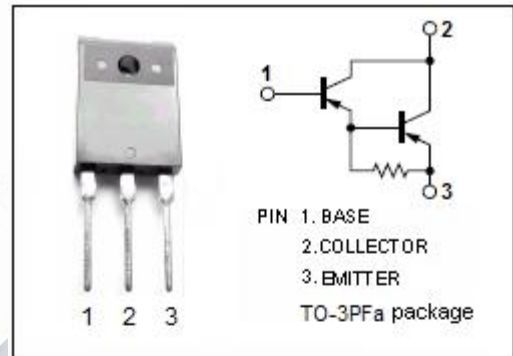

isc Silicon PNP Darlington Power Transistor**2SB1253****ELECTRICAL CHARACTERISTICS** $T_C=25^\circ\text{C}$ unless otherwise specified

SYMBOL	PARAMETER	CONDITIONS	MIN	TYP.	MAX	UNIT
$V_{(BR)CEO}$	Collector-Emitter Breakdown Voltage	$I_C = -30\text{mA}; I_B = 0$	-110			V
$V_{CE(sat)}$	Collector-Emitter Saturation Voltage	$I_C = -5\text{A}; I_B = -5\text{mA}$			-2.5	V
$V_{BE(sat)}$	Base-Emitter Saturation Voltage	$I_C = -5\text{A}; I_B = -5\text{mA}$			-3.0	V
I_{CBO}	Collector Cutoff Current	$V_{CB} = -130\text{V}; I_E = 0$			-100	μA
I_{CEO}	Collector Cutoff Current	$V_{CE} = -110\text{V}; I_B = 0$			-100	μA
I_{EBO}	Emitter Cutoff Current	$V_{EB} = -5\text{V}; I_C = 0$			-100	μA
h_{FE-1}	DC Current Gain	$I_C = -1\text{A}; V_{CE} = -5\text{V}$	2000			
h_{FE-2}	DC Current Gain	$I_C = -5\text{A}; V_{CE} = -5\text{V}$	5000		30000	
f_T	Current-Gain—Bandwidth Product	$I_C = -0.5\text{A}; V_{CE} = -10\text{V}$		20		MHz

Switching Times

t_{on}	Turn-on Time	$I_C = -5\text{A}; I_{B1} = -I_{B2} = -5\text{mA}, V_{CC} = -50\text{V},$		0.9		μs
t_{stg}	Storage Time			2.5		μs
t_f	Fall Time			1.7		μs

◆ **h_{FE-2} Classifications**

Q	P
5000-15000	8000-30000