

isc Silicon NPN Power Transistor

2SC3996

DESCRIPTION

- High Switching Speed
- High Breakdown Voltage-
: $V_{(BR)CBO} = 1500V(\text{Min})$

APPLICATIONS

- Designed for horizontal deflection output applications.

ABSOLUTE MAXIMUM RATINGS($T_a=25^\circ\text{C}$)

SYMBOL	PARAMETER	VALUE	UNIT
V_{CBO}	Collector-Base Voltage	1500	V
V_{CEO}	Collector-Emitter Voltage	800	V
V_{EBO}	Emitter-Base Voltage	6	V
I_C	Collector Current-Continuous	15	A
I_{CM}	Collector Current-Pulse	35	A
P_C	Collector Power Dissipation @ $T_C=25^\circ\text{C}$	180	W
T_J	Junction Temperature	150	$^\circ\text{C}$
T_{stg}	Storage Temperature Range	-55~150	$^\circ\text{C}$

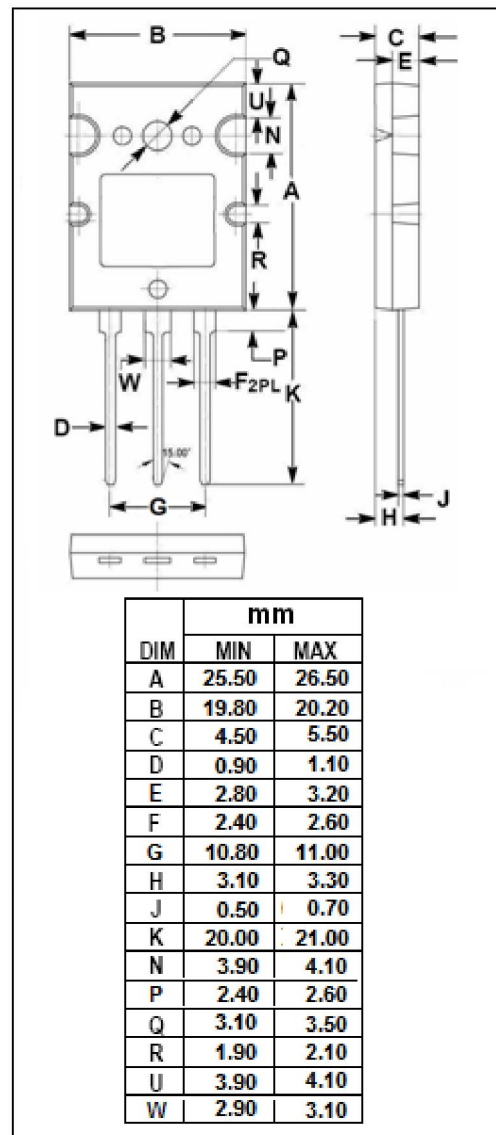
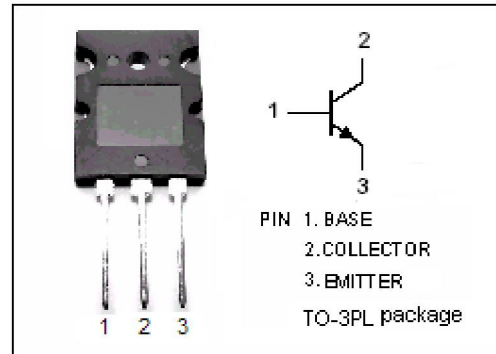

isc Silicon NPN Power Transistor**2SC3996****ELECTRICAL CHARACTERISTICS** $T_C=25^{\circ}\text{C}$ unless otherwise specified

SYMBOL	PARAMETER	CONDITIONS	MIN	TYP.	MAX	UNIT
$V_{CEO(SUS)}$	Collector-Emitter Sustaining Voltage	$I_C=100\text{mA}; I_B=0$	800			V
$V_{CE(sat)}$	Collector-Emitter Saturation Voltage	$I_C=12\text{A}; I_B=3\text{A}$			5.0	V
$V_{BE(sat)}$	Base-Emitter Saturation Voltage	$I_C=12\text{A}; I_B=3\text{A}$			1.5	V
I_{CBO}	Collector Cutoff Current	$V_{CB}=800\text{V}; I_E=0$			10	μA
I_{CES}	Collector Cutoff Current	$V_{CE}=1500\text{V}; R_{BE}=0$			1.0	mA
I_{EBO}	Emitter Cutoff Current	$V_{EB}=4\text{V}; I_C=0$			1.0	mA
h_{FE-1}	DC Current Gain	$I_C=1\text{A}; V_{CE}=5\text{V}$	8		40	
h_{FE-2}	DC Current Gain	$I_C=12\text{A}; V_{CE}=5\text{V}$	4		8	
t_{stg}	Storage Time	$I_C=12\text{A}; I_{B1}=2.4\text{A}; I_{B2}=-4.8\text{A}$			3.0	μs
t_f	Fall Time				0.2	μs