

isc Silicon NPN Power Transistor

2SC4234

DESCRIPTION

- Collector-Emitter Sustaining Voltage-
: $V_{CEO(SUS)} = 800V(\text{Min})$
- Fast Switching speed

APPLICATIONS

- Electronic ballasts for fluorescent lighting
- Switch mode power supplies

ABSOLUTE MAXIMUM RATINGS($T_a=25^\circ\text{C}$)

SYMBOL	PARAMETER	VALUE	UNIT
V_{CBO}	Collector-Base Voltage	1200	V
V_{CEO}	Collector-Emitter Voltage	800	V
V_{EBO}	Emitter-Base Voltage	7	V
I_C	Collector Current-Continuous	3	A
I_{CM}	Collector Current-Peak	6	A
I_B	Base Current-Continuous	1	A
I_{BM}	Base Current-Peak	2	A
P_T	Total Power Dissipation @ $T_C=25^\circ\text{C}$	45	W
T_J	Junction Temperature	150	$^\circ\text{C}$
T_{stg}	Storage Temperature Range	-55~150	$^\circ\text{C}$

THERMAL CHARACTERISTICS

SYMBOL	PARAMETER	MAX	UNIT
$R_{th\ j-c}$	Thermal Resistance, Junction to Case	2.77	$^\circ\text{C/W}$

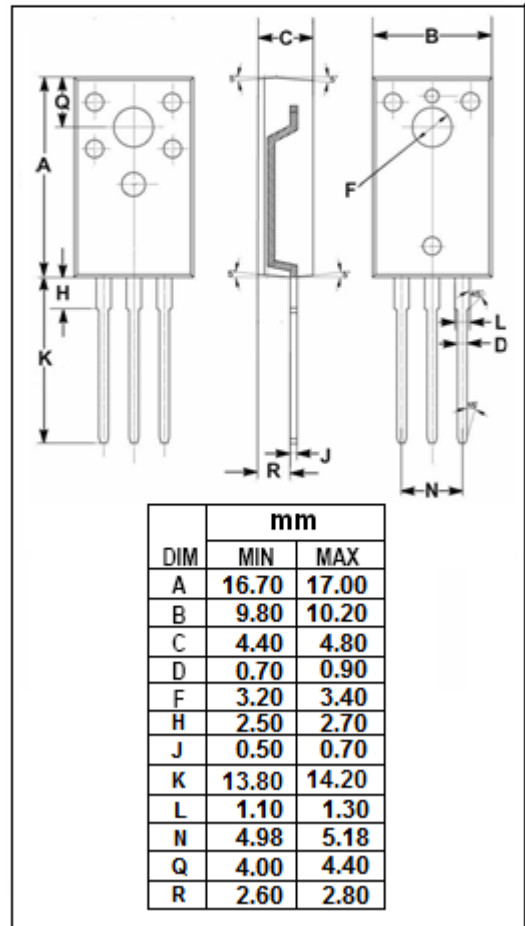
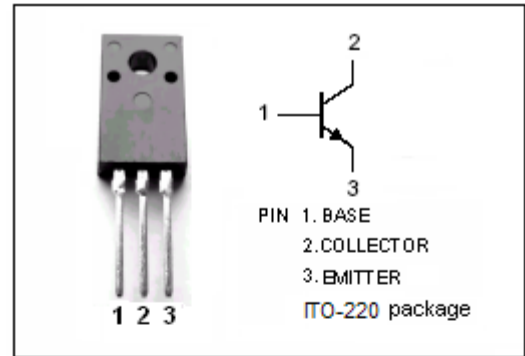

isc Silicon NPN Power Transistor

2SC4234

ELECTRICAL CHARACTERISTICS

 $T_C=25^\circ\text{C}$ unless otherwise specified

SYMBOL	PARAMETER	CONDITIONS	MIN	TYP.	MAX	UNIT
$V_{CEO(SUS)}$	Collector-Emitter Sustaining Voltage	$I_C=0.1\text{A}; I_B=0$	800			V
$V_{CE(sat)}$	Collector-Emitter Saturation Voltage	$I_C=1.5\text{A}; I_B=0.3\text{A}$			1.0	V
$V_{BE(sat)}$	Base-Emitter Saturation Voltage	$I_C=1.5\text{A}; I_B=0.3\text{A}$			1.5	V
I_{CBO}	Collector Cutoff Current	At rated Voltage			100	μA
I_{CEO}	Collector Cutoff Current	At rated Voltage			100	μA
I_{EBO}	Emitter Cutoff Current	At rated Voltage			100	μA
h_{FE-1}	DC Current Gain	$I_C=1.5\text{A}; V_{CE}=5\text{V}$	8			
h_{FE-2}	DC Current Gain	$I_C=1\text{mA}; V_{CE}=5\text{V}$	7			
f_T	Current-Gain—Bandwidth Product	$I_C=0.3\text{A}; V_{CE}=10\text{V}$		8		MHz

Switching times

t_{on}	Turn-on Time	$I_C=1.5\text{A}; I_{B1}=0.3\text{A}; I_{B2}=-0.6\text{A}$ $R_L=170\Omega; V_{BB2}=4\text{V}$			0.5	μs
t_{stg}	Storage Time				3.5	μs
t_f	Fall Time				0.3	μs

isc Silicon NPN Power Transistor

2SC4234

$h_{FE}-I_C$ Characteristics

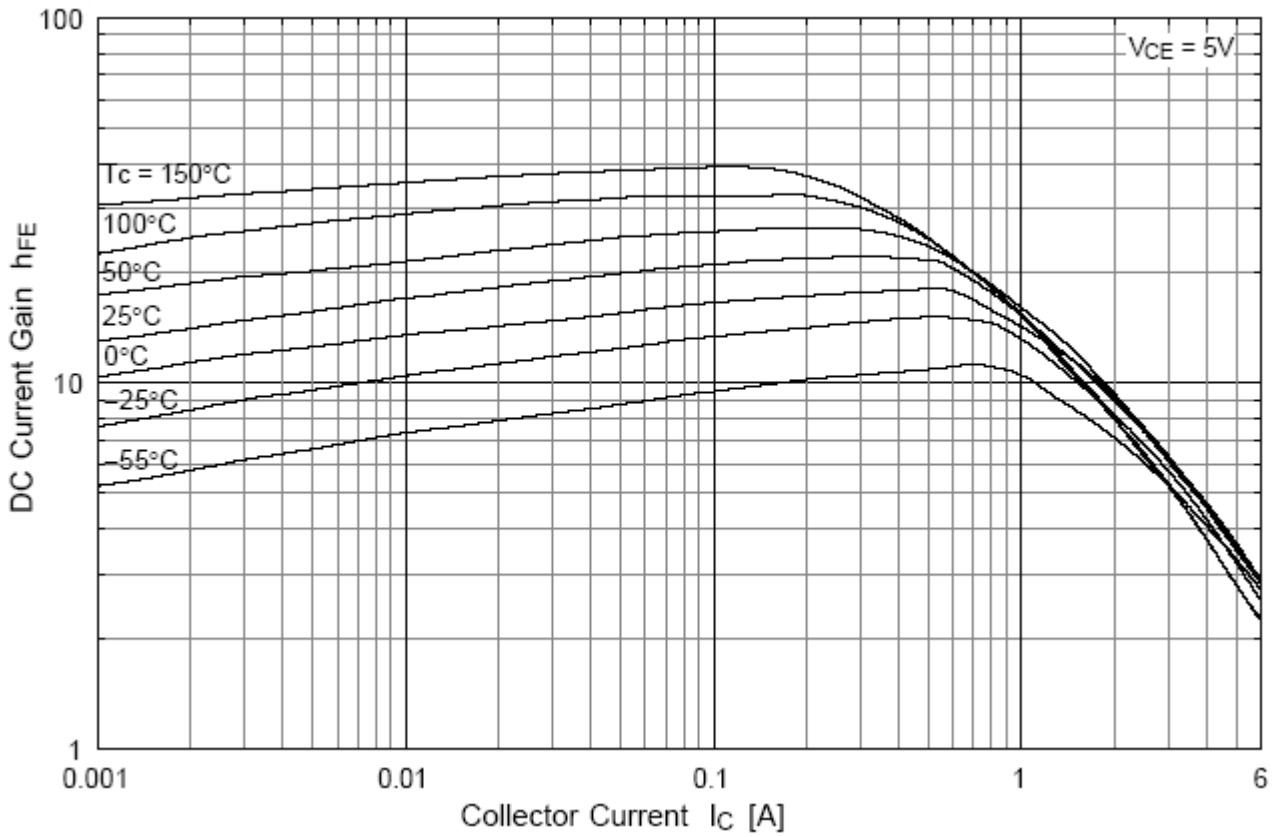

$V_{CE(sat)}-I_B$ & $V_{BE(sat)}-I_B$ Characteristics

