

NPN Transistors

2SD1253A

■ Features

- High forward current transfer ratio h_{FE} which has satisfactory linearity
- Low collector to emitter saturation voltage $V_{CE(sat)}$
- Complementary to 2SB930A

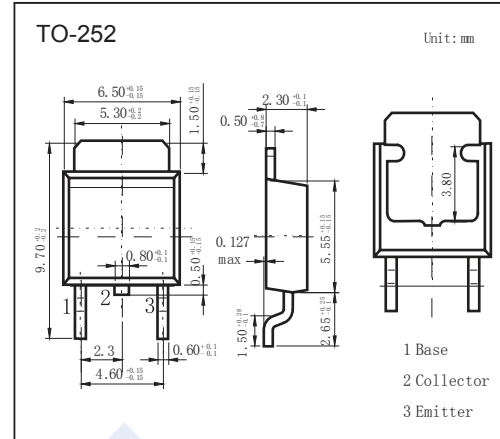

■ Absolute Maximum Ratings $T_a = 25^\circ\text{C}$

Parameter	Symbol	Rating	Unit	
Collector - Base Voltage	V_{CBO}	80	V	
Collector - Emitter Voltage	V_{CEO}	80		
Emitter - Base Voltage	V_{EBO}	5		
Collector Current - Continuous	I_C	4	A	
Collector Current - Pulse	I_{CP}	8		
Collector Power Dissipation	P_C	$T_c = 25^\circ\text{C}$	40	W
		$T_a = 25^\circ\text{C}$	1.3	
Junction Temperature	T_J	150	$^\circ\text{C}$	
Storage Temperature Range	T_{stg}	-55 to 150		

■ Electrical Characteristics $T_a = 25^\circ\text{C}$

Parameter	Symbol	Test Conditions	Min	Typ	Max	Unit
Collector-base breakdown voltage	V_{CBO}	$I_C = 100 \mu\text{A}$, $I_E = 0$	80			V
Collector-emitter breakdown voltage	V_{CEO}	$I_C = 30 \text{mA}$, $I_B = 0$	80			
Emitter - base breakdown voltage	V_{EBO}	$I_E = 100 \mu\text{A}$, $I_C = 0$	5			
Collector-base cut-off current	I_{CBO}	$V_{CB} = 80 \text{V}$, $I_E = 0$			0.1	mA
Collector cutoff current	I_{CES}	$V_{CB} = 80 \text{V}$, $I_E = 0$			400	
Collector cutoff current	I_{CEO}	$V_{CB} = 60 \text{V}$, $I_E = 0$			700	uA
Emitter cut-off current	I_{EBO}	$V_{EB} = 5 \text{V}$, $I_C = 0$			0.1	
Collector-emitter saturation voltage	$V_{CE(sat)}$	$I_C = 4 \text{A}$, $I_B = 400 \text{mA}$			1.5	V
Base - emitter saturation voltage	$V_{BE(sat)}$	$I_C = 4 \text{A}$, $I_B = 400 \text{mA}$			1.2	
Base - emitter voltage	V_{BE}	$V_{CE} = 4 \text{V}$, $I_C = 3 \text{A}$			2	
DC current gain	$h_{FE(1)}$	$V_{CE} = 4 \text{V}$, $I_C = 1 \text{A}$	40		250	
	$h_{FE(2)}$	$V_{CE} = 4 \text{V}$, $I_C = 3 \text{A}$	15			
Turn-on time	t_{on}	$I_C = 4 \text{A}$, $I_{B1} = 0.4 \text{A}$, $I_{B2} = -0.4 \text{A}$, $V_{CC} = 50 \text{V}$		0.4		us
Storage time	t_{stg}			1.2		
Fall time	t_f			0.5		
Transition frequency	f_T	$V_{CE} = 5 \text{V}$, $I_C = 500 \text{mA}$, $f = 10 \text{MHz}$		20		MHz

■ Classification of $h_{FE(1)}$

Type	2SD1253A-R	2SD1253A-Q	2SD1253A-P
Marking	40-90	70-150	120-250

NPN Transistors

2SD1253A

■ Typical Characteristics

