

Silicon NPN Power Transistors

2SD1655

DESCRIPTION

- With TO-3PML package
- High voltage;high speed
- High reliability.

APPLICATIONS

- For color TV horizontal deflection output applications

PINNING

PIN	DESCRIPTION
1	Base
2	Collector
3	Emitter

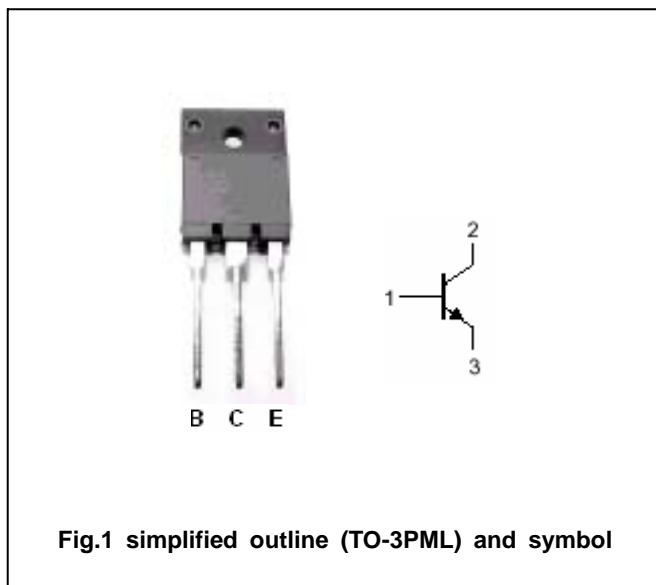

Absolute maximum ratings(Ta=25)

SYMBOL	PARAMETER	CONDITIONS	VALUE	UNIT
V_{CBO}	Collector-base voltage	Open emitter	1500	V
V_{CEO}	Collector-emitter voltage	Open base	800	V
V_{EBO}	Emitter-base voltage	Open collector	6	V
I_C	Collector current		5	A
I_{CM}	Collector current-peak		16	A
P_C	Collector power dissipation	$T_C=25$	60	W
T_j	Junction temperature		150	
T_{stg}	Storage temperature		-55~150	

Silicon NPN Power Transistors

2SD1655

CHARACTERISTICS

T_j=25 unless otherwise specified

SYMBOL	PARAMETER	CONDITIONS	MIN	TYP.	MAX	UNIT
V _{(BR)CEO}	Collector-emitter breakdown voltage	I _C =0.1A; R _{BE} =	800			
V _{(BR)CBO}	Collector-base breakdown voltage	I _C =5mA; I _E =0	1500			
V _{CEsat}	Collector-emitter saturation voltage	I _C =4A; I _B =0.8A			5.0	V
V _{BEsat}	Base-emitter saturation voltage	I _C =4A; I _B =0.8A			1.5	V
I _{EBO}	Emitter cut-off current	V _{EB} =5V; I _C =0			1.0	mA
I _{CBO}	Collector cut-off current	V _{CB} =800V; I _E =0			10	μA
h _{FE}	DC current gain	I _C =1 A ; V _{CE} =5V	8			
f _T	Transition frequency	I _C =1 A ; V _{CE} =10V		3		MHz
t _f	Fall time	I _C =4A; I _{B1} =0.8A; I _{B2} =-1.6A V _{CC} =200V; R _L =50			0.7	μs

Silicon NPN Power Transistors

2SD1655

PACKAGE OUTLINE

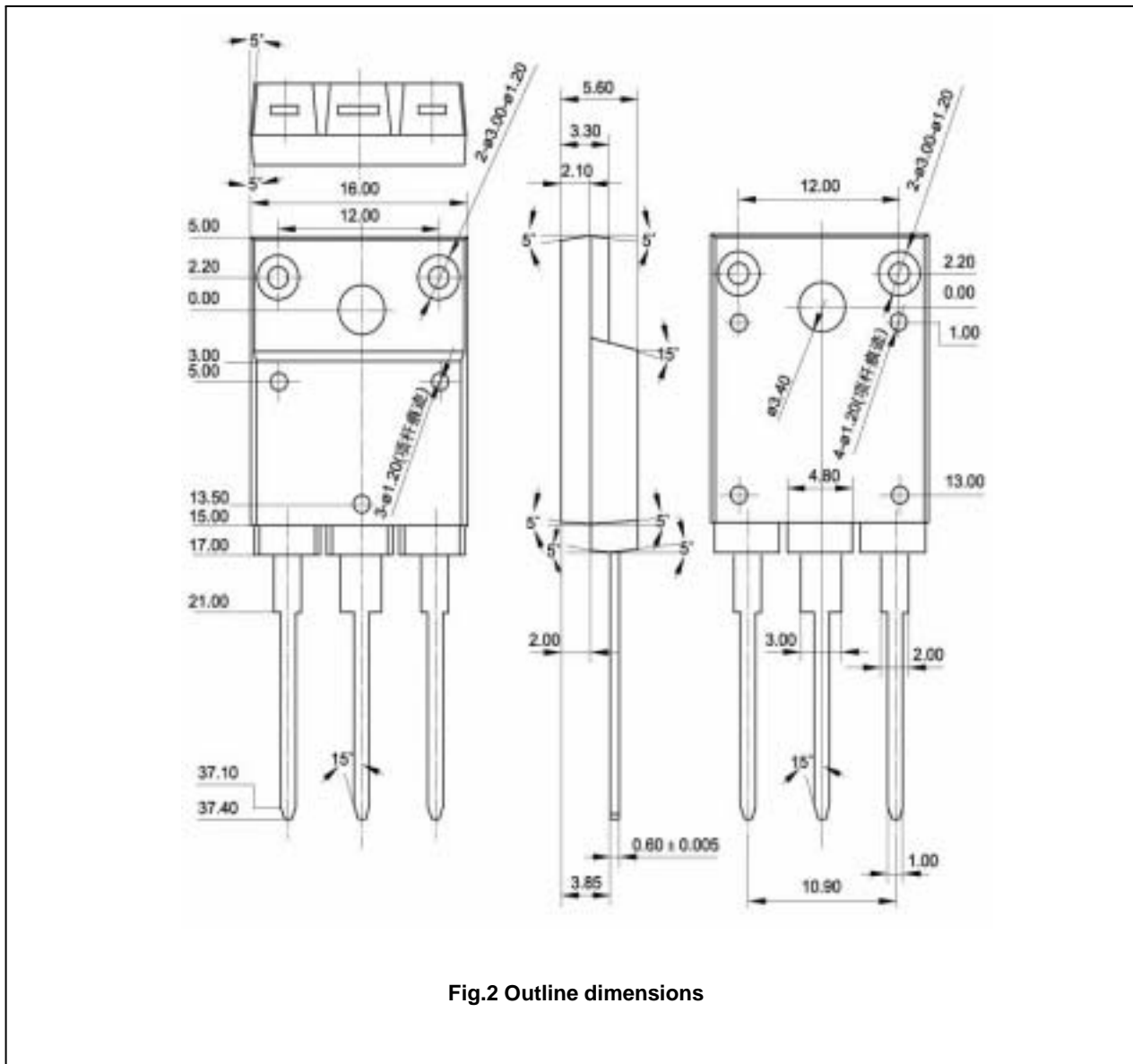

Fig.2 Outline dimensions