

Silicon NPN Power Transistors

2SD2340

DESCRIPTION

- With TO-3PN package
- DARLINGTON
- High DC current gain

APPLICATIONS

- Audio ,regulator and general purpose

PINNING

PIN	DESCRIPTION
1	Base
2	Collector;connected to mounting base
3	Emitter

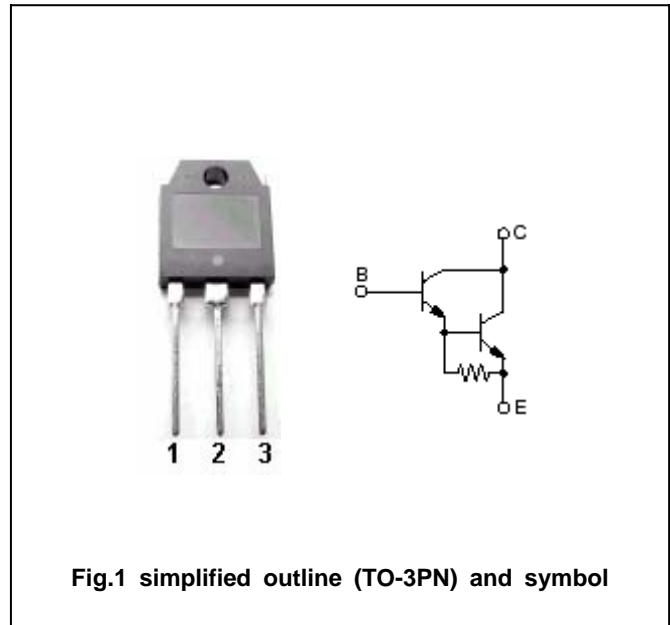

Fig.1 simplified outline (TO-3PN) and symbol

Absolute maximum ratings(Ta=°C)

SYMBOL	PARAMETER	CONDITIONS	VALUE	UNIT
V _{CBO}	Collector-base voltage	Open emitter	130	V
V _{CEO}	Collector-emitter voltage	Open base	110	V
V _{EBO}	Emitter-base voltage	Open collector	5	V
I _C	Collector current		6	A
P _C	Collector power dissipation	T _C =25°C	50	W
		T _a =25°C	2.5	
T _j	Junction temperature		150	°C
T _{stg}	Storage temperature		-55~150	°C

Silicon NPN Power Transistors

2SD2340

CHARACTERISTICS

T_j=25°C unless otherwise specified

SYMBOL	PARAMETER	CONDITIONS	MIN	TYP.	MAX	UNIT
V _{(BR)CEO}	Collector-emitter breakdown voltage	I _C =30mA ; I _B =0	110			V
V _{CEsat}	Collector-emitter saturation voltage	I _C =5A ; I _B =5mA			2.5	V
V _{BEsat}	Base-emitter saturation voltage	I _C =5A ; I _B =5mA			3.0	V
I _{CBO}	Collector cut-off current	V _{CB} =130V; I _E =0			100	μ A
I _{CEO}	Collector cut-off current	V _{CE} =110V I _B =0			100	μ A
I _{EBO}	Emitter cut-off current	V _{EB} =5V; I _C =0			100	μ A
h _{FE}	DC current gain	I _C =3A ; V _{CE} =5V	5000			
f _T	Transition frequency	I _C =0.5A ; V _{CE} =10V		20		MHz

Silicon NPN Power Transistors

2SD2340

PACKAGE OUTLINE

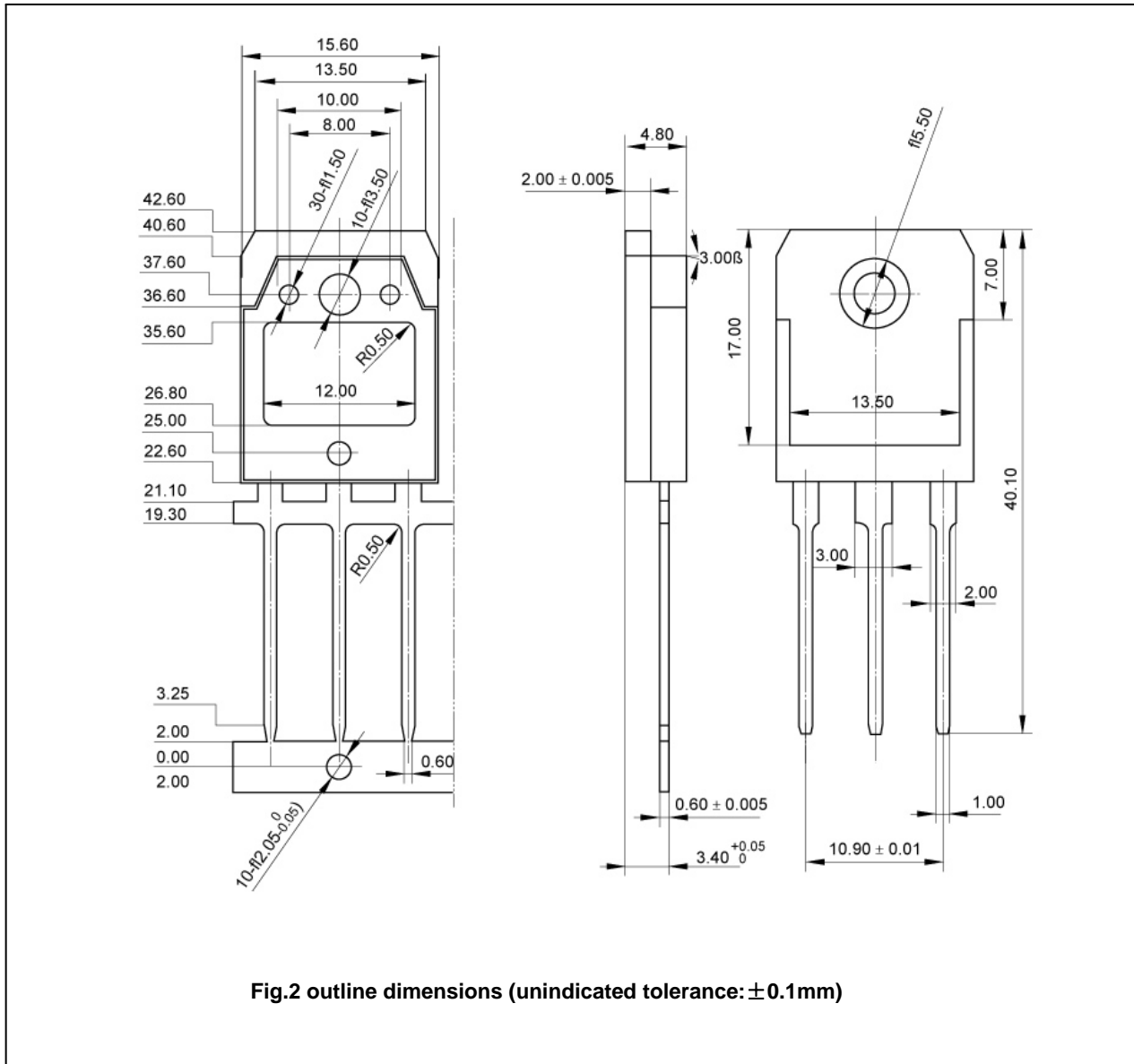

Fig.2 outline dimensions (unindicated tolerance: ± 0.1 mm)