

# 2SD2530

## Silicon NPN triple diffusion planer type Darlington

For power amplification

### ■ Features

- High forward current transfer ratio  $h_{FE}$
- Allowing supply with the radial taping
- Low collector to emitter saturation voltage  $V_{CE(sat)}: < 2.5 \text{ V}$

### ■ Absolute Maximum Ratings $T_C = 25^\circ\text{C}$

Parameter	Symbol	Rating	Unit	
Collector to base voltage	$V_{CBO}$	100	V	
Collector to emitter voltage	$V_{CEO}$	100	V	
Emitter to base voltage	$V_{EBO}$	5	V	
Peak collector current	$I_{CP}$	10	A	
Collector current	$I_C$	5	A	
Collector power dissipation	$P_C$	$T_C = 25^\circ\text{C}$	15	W
		$T_a = 25^\circ\text{C}$	2	
Junction temperature	$T_j$	150	$^\circ\text{C}$	
Storage temperature	$T_{stg}$	-55 to +150	$^\circ\text{C}$	

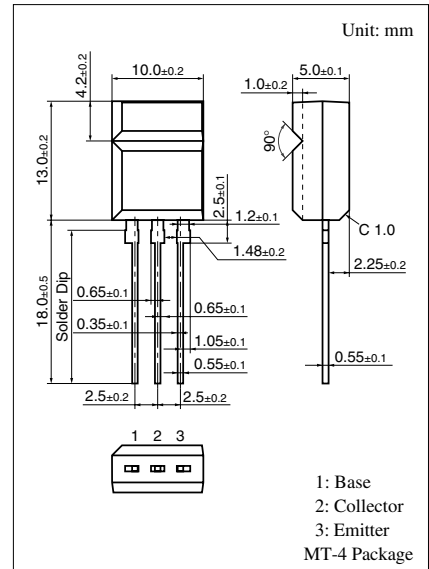

### Internal Connection

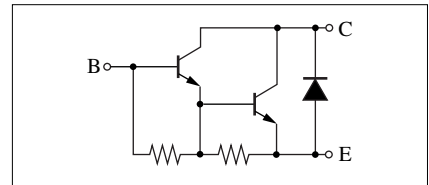

### ■ Electrical Characteristics $T_C = 25^\circ\text{C} \pm 2^\circ\text{C}$

Parameter	Symbol	Conditions	Min	Typ	Max	Unit
Collector cutoff current	$I_{CBO}$	$V_{CB} = 100 \text{ V}, I_E = 0$			100	$\mu\text{A}$
	$I_{CEO}$	$V_{CE} = 80 \text{ V}, I_B = 0$			100	$\mu\text{A}$
Emitter cutoff current	$I_{EBO}$	$V_{EB} = 5 \text{ V}, I_C = 0$			5	mA
Collector to emitter voltage	$V_{CEO}$	$I_C = 10 \text{ mA}, I_B = 0$	100			V
Forward current transfer ratio	$h_{FE1}$	$V_{CE} = 4 \text{ V}, I_C = 2 \text{ A}$	2 000		15 000	
	$h_{FE2}$	$V_{CE} = 4 \text{ V}, I_C = 4 \text{ A}$	500			
Collector to emitter saturation voltage	$V_{CE(sat)}$	$I_C = 2 \text{ A}, I_B = 2 \text{ mA}$			1.5	V
		$I_C = 4 \text{ A}, I_B = 16 \text{ mA}$			2.5	V
Base to emitter saturation voltage	$V_{BE(sat)}$	$I_C = 4 \text{ A}, I_B = 16 \text{ mA}$			2.5	V
Transition frequency	$f_T$	$V_{CE} = 10 \text{ V}, I_C = 0.5 \text{ A}, f = 1 \text{ MHz}$		20		MHz
Turn-on time	$t_{on}$	$I_C = 4 \text{ A}, I_{B1} = 16 \text{ mA}, I_{B2} = -16 \text{ mA}$		0.27		$\mu\text{s}$
Storage time	$t_{stg}$	$V_{CC} = 50 \text{ V}$		2.9		$\mu\text{s}$
Fall time	$t_f$			1.0		$\mu\text{s}$