

> **Features**

- Include Fast Recovery Diode
- High Voltage
- Low Driving Power

> **Applications**

- Motor Control
- Inverters
- Choppers

> **Outline Drawing**

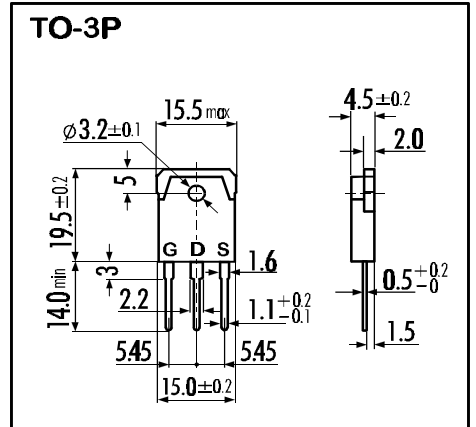

> **Maximum Ratings and Characteristics**

- Absolute Maximum Ratings ( $T_C=25^\circ\text{C}$ ), unless otherwise specified

Item	Symbol	Rating	Unit
Drain-Source-Voltage	$V_{DS}$	500	V
Continuous Drain Current	$I_D$	15	A
Pulsed Drain Current	$I_{D(puls)}$	60	A
Continuous Reverse Drain Current	$I_{DR}$	15	A
Gate-Source-Voltage	$V_{GS}$	$\pm 20$	V
Max. Power Dissipation	$P_D$	125	W
Operating and Storage Temperature Range	$T_{ch}$	150	$^\circ\text{C}$
	$T_{stg}$	-55 ~ +150	$^\circ\text{C}$

> **Equivalent Circuit**

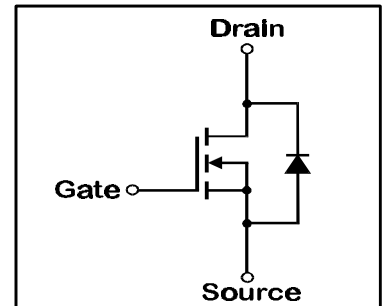

- Electrical Characteristics ( $T_C=25^\circ\text{C}$ ), unless otherwise specified

Item	Symbol	Test conditions	Min.	Typ.	Max.	Unit
Drain-Source Breakdown-Voltage	$V_{(BR)DSS}$	$I_D=1\text{mA}$ $V_{GS}=0\text{V}$	500			V
Gate Threshold Voltage	$V_{GS(th)}$	$I_D=10\text{mA}$ $V_{DS}=V_{GS}$	2,1	3,0	4,0	V
Zero Gate Voltage Drain Current	$I_{DSS}$	$V_{DS}=500\text{V}$ $T_{ch}=25^\circ\text{C}$ $V_{GS}=0\text{V}$		10	500	$\mu\text{A}$
Gate Source Leakage Current	$I_{GSS}$	$V_{GS}=\pm 20\text{V}$ $V_{DS}=0\text{V}$		10	100	nA
Drain Source On-State Resistance	$R_{DS(on)}$	$I_D=8\text{A}$ $V_{GS}=10\text{V}$		0,4	0,58	$\Omega$
Forward Transconductance	$g_{fs}$	$I_D=8\text{A}$ $V_{DS}=25\text{V}$	7	13		S
Input Capacitance	$C_{iss}$	$V_{DS}=25\text{V}$		2000	3000	pF
Output Capacitance	$C_{oss}$	$V_{GS}=0\text{V}$		270	400	pF
Reverse Transfer Capacitance	$C_{rss}$	$f=1\text{MHz}$		140	210	pF
Turn-On-Time $t_{on}$ ( $t_{on}=t_{d(on)}+t_r$ )	$t_{d(on)}$	$V_{CC}=300\text{V}$		30	45	ns
	$t_r$	$I_D=15\text{A}$		100	150	ns
Turn-Off-Time $t_{off}$ ( $t_{off}=t_{d(off)}+t_f$ )	$t_{d(off)}$	$V_{GS}=10\text{V}$		400	600	ns
	$t_f$	$R_{GS}=25\ \Omega$		160	240	ns
Diode Forward On-Voltage	$V_{SD}$	$I_F=I_{DR}$ $V_{GS}=0\text{V}$ $T_{ch}=25^\circ\text{C}$		0,95	1,8	V
Reverse Recovery Time	$t_{rr}$	$I_F=I_{DR}$ $V_{GS}=0\text{V}$		150	200	ns
		$-di_F/dt=100\text{A}/\mu\text{s}$ $T_{ch}=25^\circ\text{C}$				

- Thermal Characteristics

Item	Symbol	Test conditions	Min.	Typ.	Max.	Unit
Thermal Resistance	$R_{th(ch-a)}$	channel to air			35	$^\circ\text{C}/\text{W}$
	$R_{th(ch-c)}$	channel to case			1,0	$^\circ\text{C}/\text{W}$

> Characteristics

Typical Output Characteristics

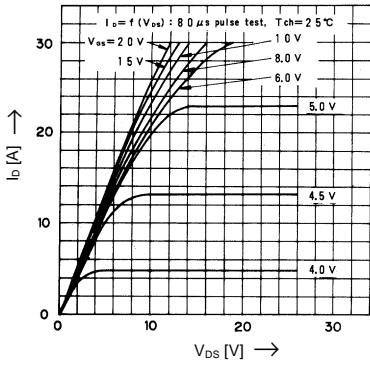

Drain-Source-On-State Resistance vs.  $T_{ch}$

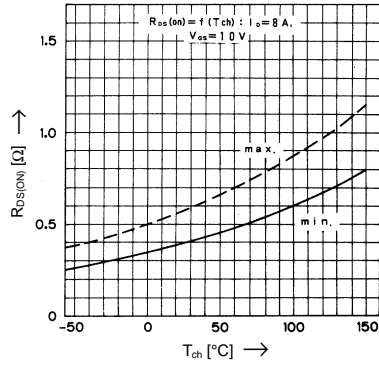

Typical Transfer Characteristics

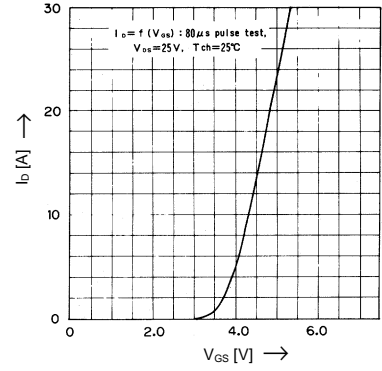

Typical Drain-Source-On-State-Resistance vs.  $I_D$

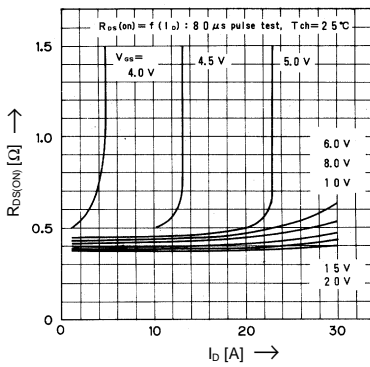

Typical Forward Transconductance vs.  $I_D$

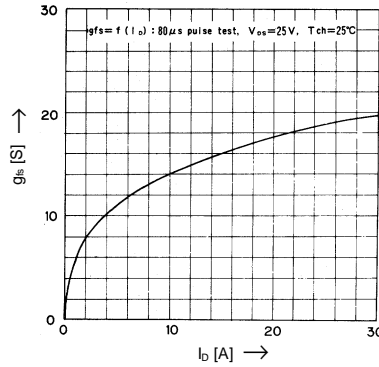

Gate Threshold Voltage vs.  $T_{ch}$

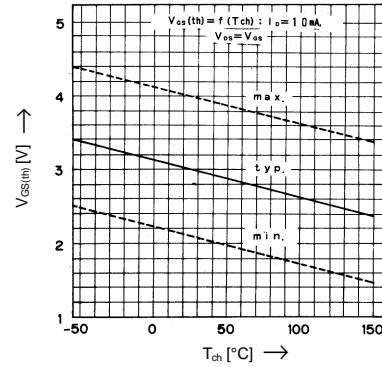

Typical Capacitance vs.  $V_{DS}$

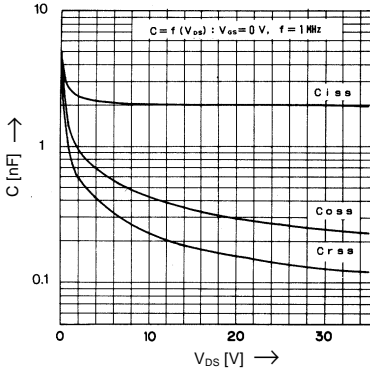

Typical Input Charge

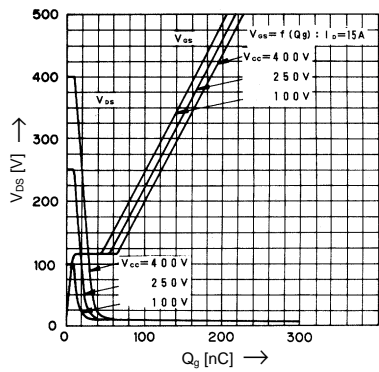

Forward Characteristics of Reverse Diode

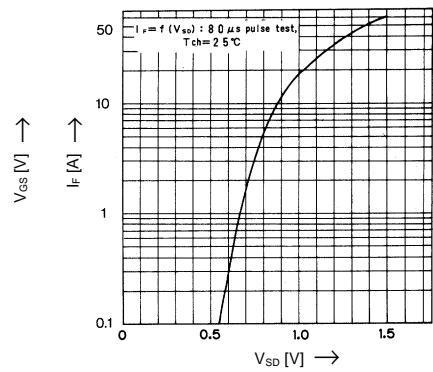

Allowable Power Dissipation vs.  $T_c$

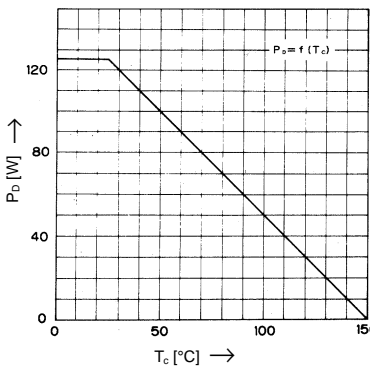

Safe operation area

