

FEATURES

- Available in Normal & Reverse Polarity
- All Diffused Series
- Industrial Grade
- Available in Avalanche Characteristic

TYPICAL APPLICATIONS

- Power supplies
- Machine tool controls
- Battery chargers
- Welders

TECHNICAL DATA

DEVICE TYPE	V_{RRM} (V)	V_{RSM} (V)
320NG40/320RG40 320NF40/320RF40	400	500
320NG120/320RG120 320NF120/320RF120	1200	1300
320NG160/320RG160 320NF160/320RF160	1600	1700

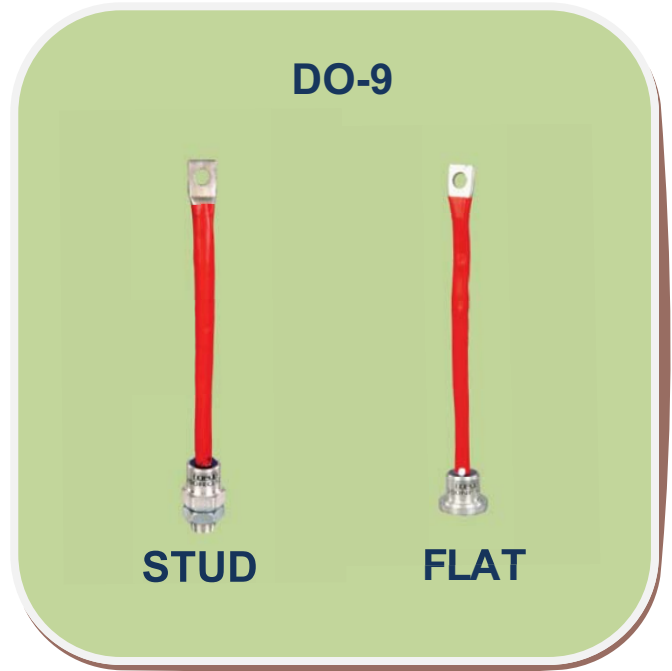

SYMBOL	CONDITIONS	VALUES
$I_{F(AV)}$	Maximum average forward Current $T_c = 130^{\circ}C$	320A
V_{FM}	Maximum peak forward Voltage drop @ Rated $I_{F(Peak)}$	1.65 V
I_{FSM}	Maximum peak one cycle (non-rep.) surge current 10 msec	5500A
I^2t	Max. I^2t rating (non-rep.) for 10 msec	151000 A ² Sec
I_{RRM}	Peak reverse current at $T_{vj} = 175^{\circ}C$	50 mA
V_0	$T_{vj} = \text{max}$	0.85 V
R_0	$T_{vj} = \text{max}$	0.45 mΩ
$R_{th(j-c)}$	Maximum thermal resistance (Junction to case)	0.12 °C/W
$R_{th(c-h)}$	Maximum thermal resistance (Case to heat sink)(NG, RG)	0.10 °C/W
$R_{th(c-h)}$	Maximum thermal resistance (Case to heat sink)(NF, RF)	0.07 °C/W
T_{vj}	Junction temperature	200 °C
T_{stg}	Storage temperature	200 °C
Mounting torque		30 Nm
Weight	Approx.	260 gms
Package Outline		G, F

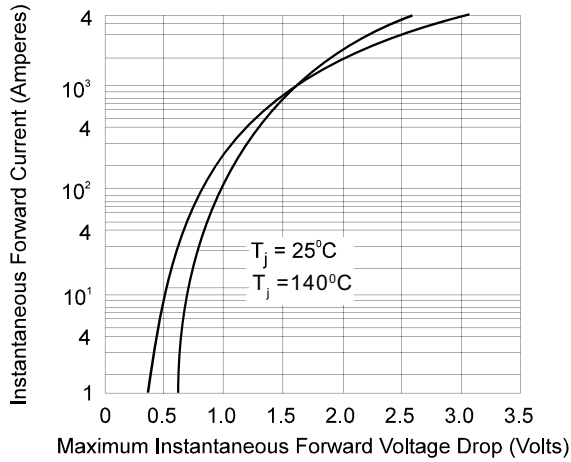

Fig. 1 - Forward Voltage Drop Vs. Forward Current

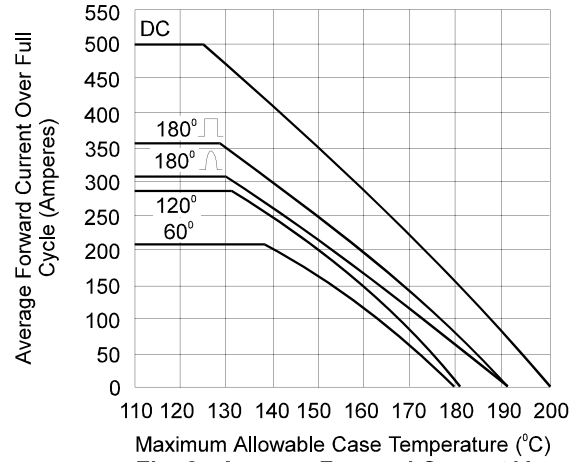

Fig. 2 - Average Forward Current Vs. Case Temperature

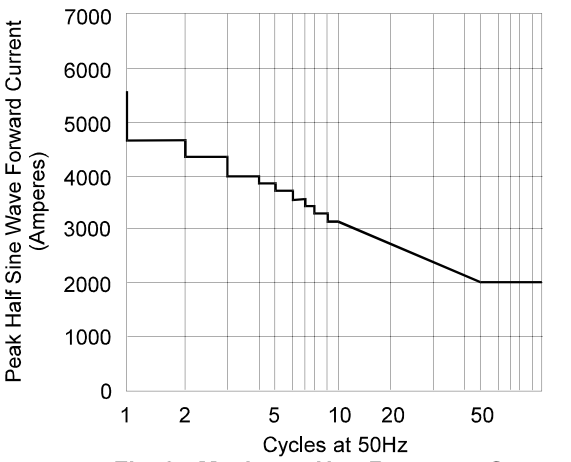

Fig. 3 - Maximum Non Recurrent Surge Current

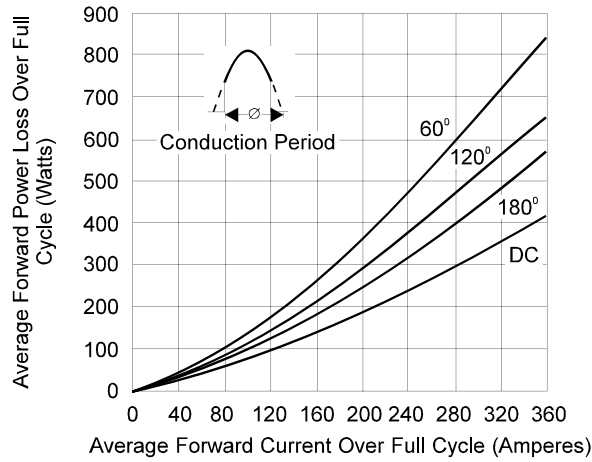

Fig. 4 - Maximum Forward Power Loss Vs. Forward Current

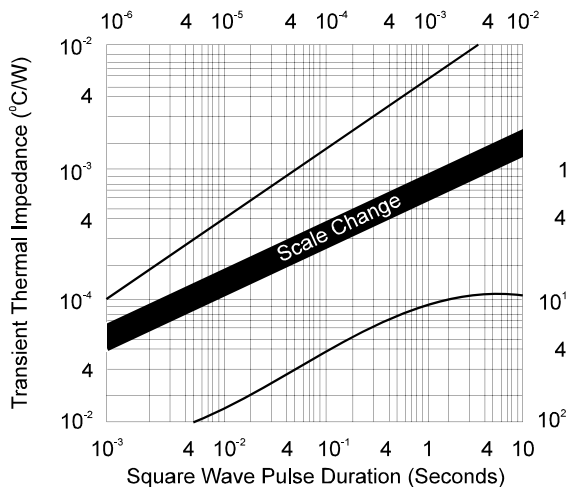

Fig. 5 - Transient Thermal Impedance

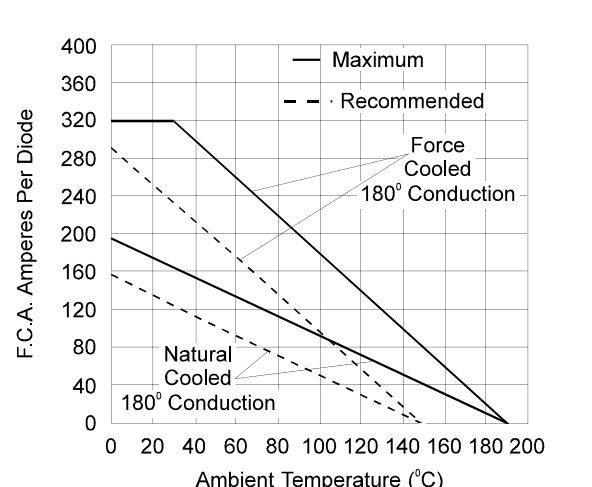
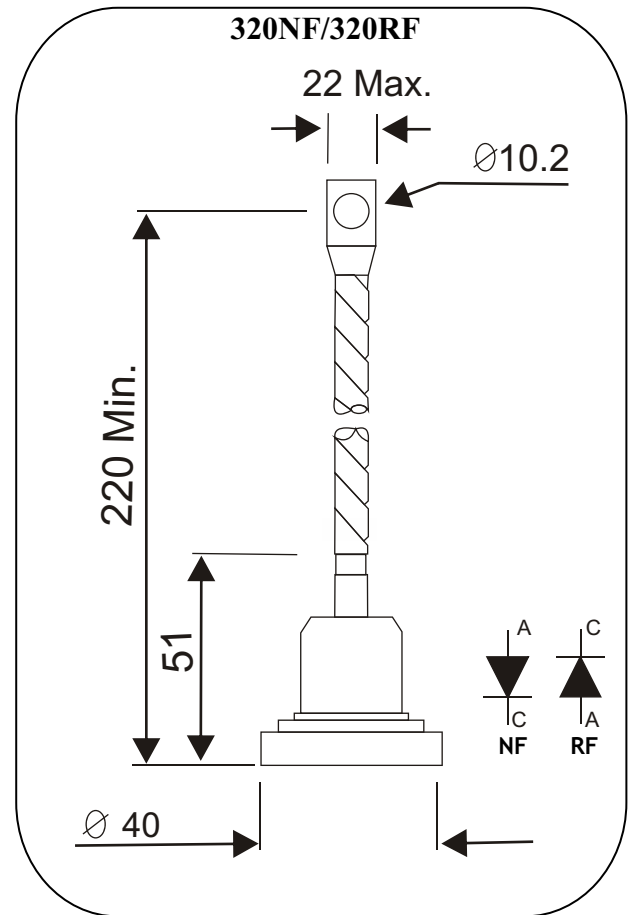
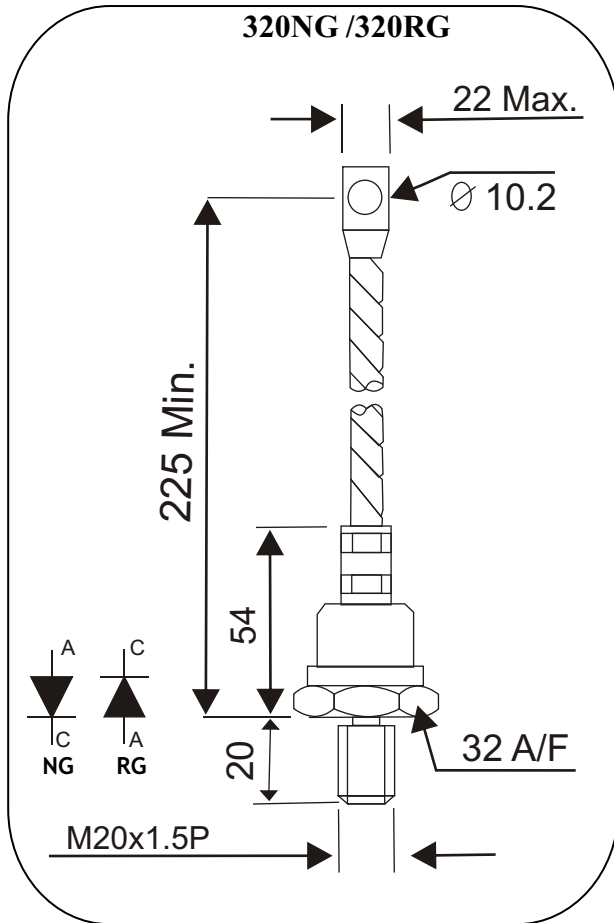

Fig. 6 - Diode 320NG/RG Mounted on Heat Sink

PACKAGE OUTLINE



All dimensions are in mm.

Insel Rectifiers (India) Pvt. Ltd.

(An ISO 9001:2015, ISO 14001:2015 Certified Company)

Plot No 151, Udyog Kendra, Extn.-II, Ecotech-III, Greater Noida-201306

Toll Free No.: 1800 3070 9989, Fax : 011-27491404

E-mail : insel@rectifierindia.com, sales@rectifierindia.com