



**3N40K-MT**

Preliminary

**Power MOSFET**

**3A, 400V N-CHANNEL  
POWER MOSFET**

■ DESCRIPTION

The UTC **3N40K-MT** is an N-channel mode power MOSFET using UTC's advanced technology to provide customers with planar stripe and DMOS technology. This technology specializes in allowing a minimum on-state resistance and superior switching performance. It also can withstand high energy pulse in the avalanche and commutation mode.

The UTC **3N40K-MT** is universally applied in electronic lamp ballast based on half bridge topology and high efficient switched mode power supply.

■ FEATURES

- \*  $R_{DS(ON)} < 2.0\Omega @ V_{GS} = 10V, I_D = 1.5A$
- \* High switching speed
- \* 100% avalanche tested

■ SYMBOL

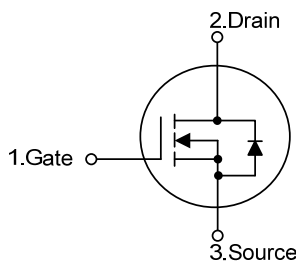

■ ORDERING INFORMATION

Ordering Number		Package	Pin Assignment			Packing
Lead Free	Halogen Free		1	2	3	
3N40KL-TA3-T	3N40KG-TA3-T	TO-220	G	D	S	Tube
3N40KL-TF3-T	3N40KG-TF3-T	TO-220F	G	D	S	Tube
3N40KL-TF1-T	3N40KG-TF1-T	TO-220F1	G	D	S	Tube
3N40KL-TF2-T	3N40KG-TF2-T	TO-220F2	G	D	S	Tube
3N40KL-TF3T-T	3N40KG-TF3T-T	TO-220F3	G	D	S	Tube
3N40KL-TM3-T	3N40KG-TM3-T	TO-251	G	D	S	Tube
3N40KL-TN3-R	3N40KG-TN3-R	TO-252	G	D	S	Tape Reel

Note: Pin Assignment: G: Gate D: Drain S: Source

<p>3N40KL-TF3-T</p> <p>(1) Packing Type</p> <p>(2) Package Type</p> <p>(3) Green Package</p>	<p>(1) T: Tube, R: Tape Reel</p> <p>(2) TA3: TO-220, TF3: TO-220F, TF1: TO-220F1, TF2: TO-220F2, TF3T: TO-220F3, TM3: TO-251, TN3: TO-252</p> <p>(3) L: Lead Free, G: Halogen Free and Lead Free</p>
--	--

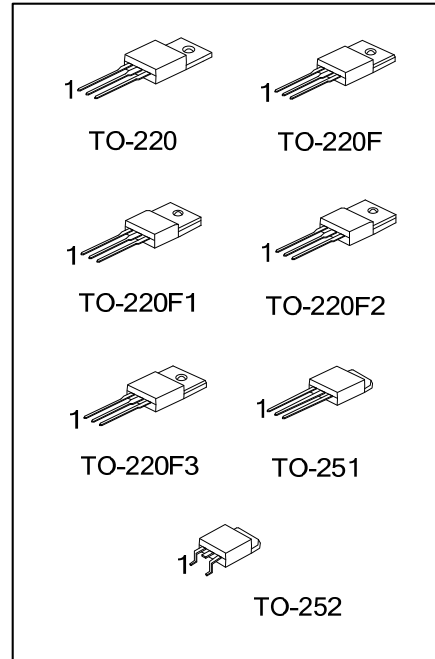

MARKING

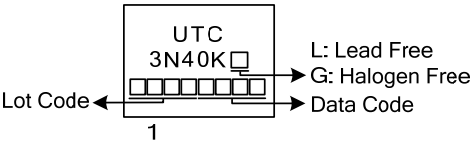

■ ABSOLUTE MAXIMUM RATINGS ( $T_C=25^\circ\text{C}$ , unless otherwise specified)

PARAMETER		SYMBOL	RATINGS	UNIT
Drain-Source Voltage		$V_{DSS}$	400	V
Gate-Source Voltage		$V_{GSS}$	$\pm 30$	V
Drain Current	Continuous ( $T_C=25^\circ\text{C}$ )	$I_D$	3	A
	Pulsed (Note 2)	$I_{DM}$	12	A
Avalanche Energy	Single Pulsed (Note 3)	$E_{AS}$	290	mJ
	Repetitive (Note 2)	$E_{AR}$	3	mJ
Power Dissipation	TO-220	$P_D$	54	W
	TO-220F/TO-220F1		25	W
	TO-220F3		26	W
	TO-251/TO-252		50	W
Junction Temperature		$T_J$	+150	$^\circ\text{C}$
Storage Temperature		$T_{STG}$	-55~+150	$^\circ\text{C}$

Notes: 1. Absolute maximum ratings are those values beyond which the device could be permanently damaged.

Absolute maximum ratings are stress ratings only and functional device operation is not implied.

2. Repetitive Rating: Pulse width limited by maximum junction temperature.

3.  $L=56\text{mH}$ ,  $I_{AS}=3.0\text{A}$ ,  $V_{DD}=50\text{V}$ ,  $R_G=25\ \Omega$ , Starting  $T_J = 25^\circ\text{C}$

4.  $I_{SD}\leq 4.4\text{A}$ ,  $di/dt \leq 200\text{A}/\mu\text{s}$ ,  $V_{DD}\leq BV_{DSS}$ , Starting  $T_J = 25^\circ\text{C}$

■ THERMAL DATA

PARAMETER		SYMBOL	RATINGS	UNIT
Junction to Ambient	TO-220/TO-220F TO-220F1/TO-220F2 TO-220F3	$\theta_{JA}$	62.5	$^\circ\text{C}/\text{W}$
	TO-251/TO-252		110	$^\circ\text{C}/\text{W}$
	TO-220		2.28	$^\circ\text{C}/\text{W}$
Junction to Case	TO-220F/TO-220F1 TO-220F3	$\theta_{JC}$	4.9	$^\circ\text{C}/\text{W}$
	TO-220F2		4.8	$^\circ\text{C}/\text{W}$
	TO-251/TO-252		2.5	$^\circ\text{C}/\text{W}$

■ ELECTRICAL CHARACTERISTICS ( $T_c=25^\circ\text{C}$ , unless otherwise specified)

PARAMETER	SYMBOL	TEST CONDITIONS	MIN	TYP	MAX	UNIT
<b>OFF CHARACTERISTICS</b>						
Drain-Source Breakdown Voltage	$BV_{DSS}$	$I_D=250\mu\text{A}$ , $V_{GS}=0\text{V}$	400			V
Breakdown Voltage Temperature Coefficient	$\Delta BV_{DSS}/\Delta T_J$	Reference to $25^\circ\text{C}$ , $I_D=250\mu\text{A}$		0.38		$\text{V}/^\circ\text{C}$
Drain-Source Leakage Current	$I_{DSS}$	$V_{DS}=400\text{V}$ , $V_{GS}=0\text{V}$			10	$\mu\text{A}$
Gate- Source Leakage Current	Forward	$V_{GS}=+30\text{V}$ , $V_{DS}=0\text{V}$			+100	nA
	Reverse	$V_{GS}=-30\text{V}$ , $V_{DS}=0\text{V}$			-100	nA
<b>ON CHARACTERISTICS</b>						
Gate Threshold Voltage	$V_{GS(TH)}$	$V_{DS}=V_{GS}$ , $I_D=250\mu\text{A}$	3.0		5.0	V
Static Drain-Source On-State Resistance	$R_{DS(ON)}$	$V_{GS}=10\text{V}$ , $I_D=1.5\text{A}$			2.0	$\Omega$
<b>DYNAMIC PARAMETERS</b>						
Input Capacitance	$C_{ISS}$	$V_{GS}=0\text{V}$ , $V_{DS}=25\text{V}$ , $f=1.0\text{MHz}$		248	350	pF
Output Capacitance	$C_{OSS}$			40	80	pF
Reverse Transfer Capacitance	$C_{RSS}$			5	9	pF
<b>SWITCHING PARAMETERS</b>						
Turn-ON Delay Time	$t_{D(ON)}$	$V_{DS}=30\text{V}$ , $I_D=0.5\text{A}$ , $R_G=25\Omega$ (Note 1, 2)		40		ns
Rise Time	$t_R$			48		ns
Turn-OFF Delay Time	$t_{D(OFF)}$			48		ns
Fall-Time	$t_F$			27		ns
Total Gate Charge	$Q_G$	$V_{GS}=10\text{V}$ , $V_{DS}=50\text{V}$ , $I_D=1.3\text{A}$ (Note 1, 2)		12.3	15	nC
Gate to Source Charge	$Q_{GS}$			4.48		nC
Gate to Drain Charge	$Q_{GD}$			2.2		nC
<b>SOURCE- DRAIN DIODE RATINGS AND CHARACTERISTICS</b>						
Maximum Body-Diode Continuous Current	$I_{SD}$				3.0	A
Maximum Body-Diode Pulsed Current	$I_{SM}$				12	A
Drain-Source Diode Forward Voltage	$V_{SD}$	$I_S=3\text{A}$ , $V_{GS}=0\text{V}$			1.5	V

Notes: 1. Pulse Test: Pulse width  $\leq 300\mu\text{s}$ , Duty cycle  $\leq 2\%$

2. Essentially independent of operating temperature

■ TEST CIRCUITS AND WAVEFORMS

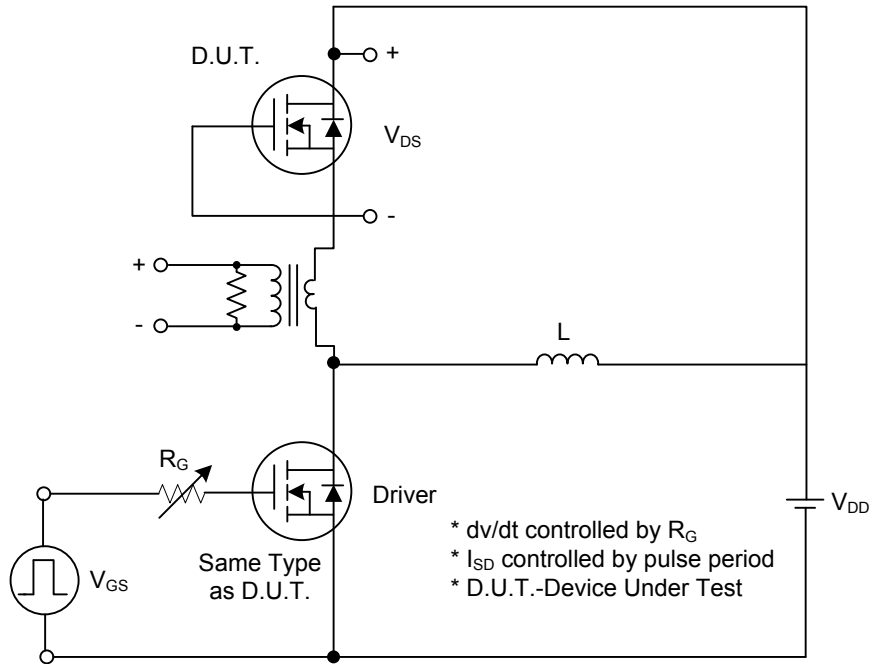

Peak Diode Recovery dv/dt Test Circuit

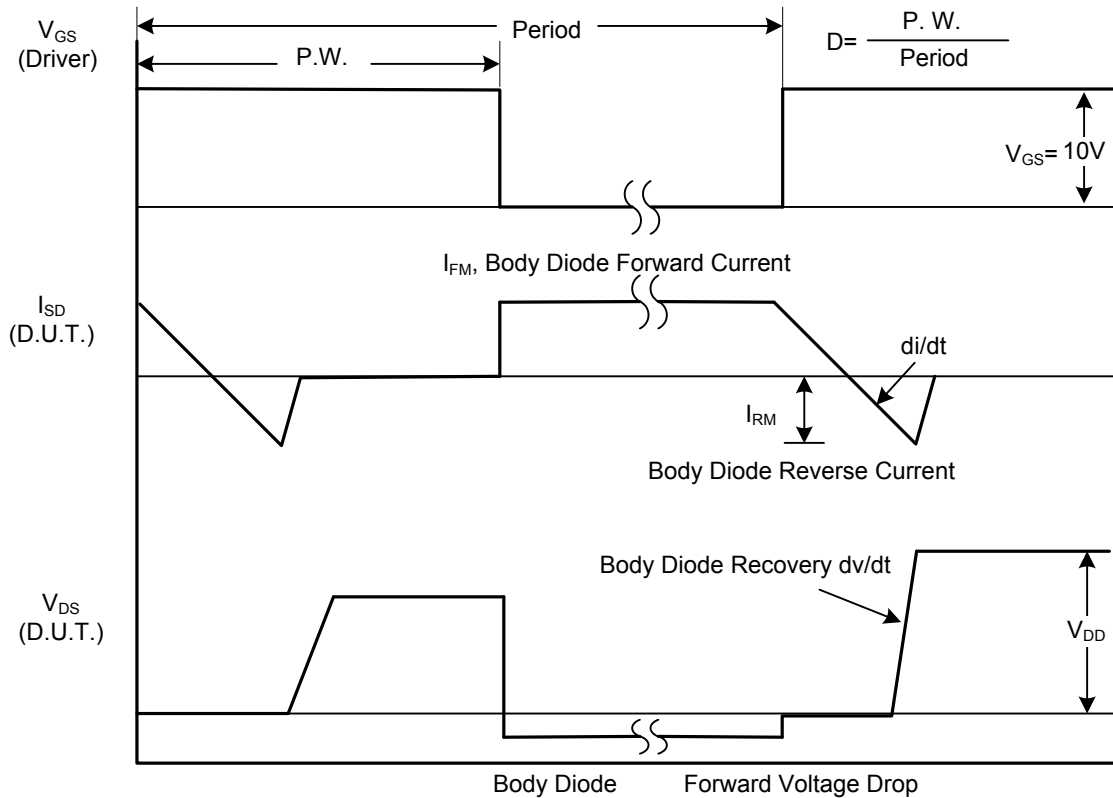

Peak Diode Recovery dv/dt Waveforms

■ TEST CIRCUITS AND WAVEFORMS (Cont.)

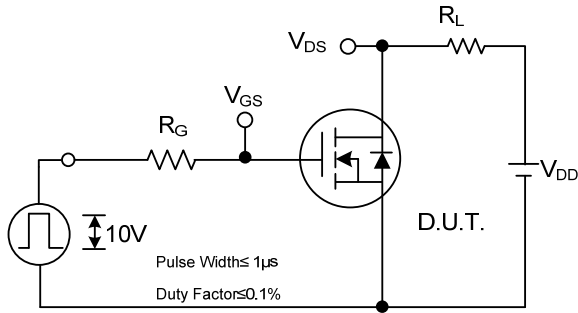

Switching Test Circuit

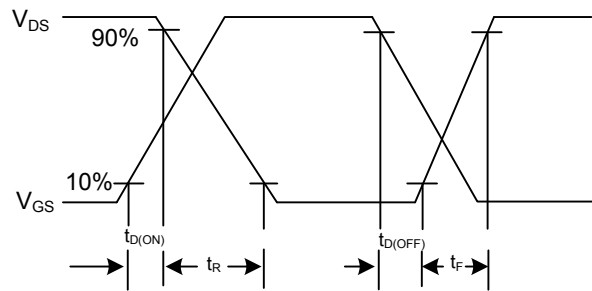

Switching Waveforms

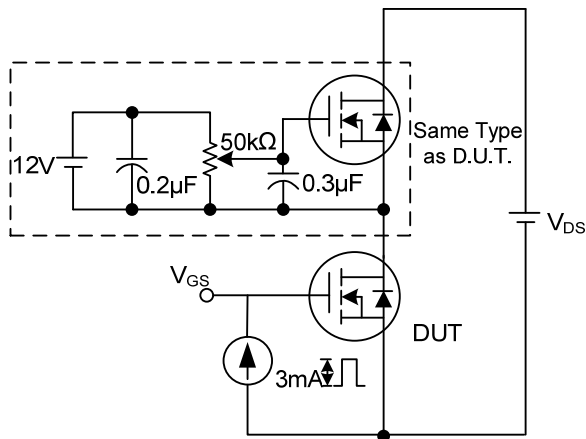

Gate Charge Test Circuit

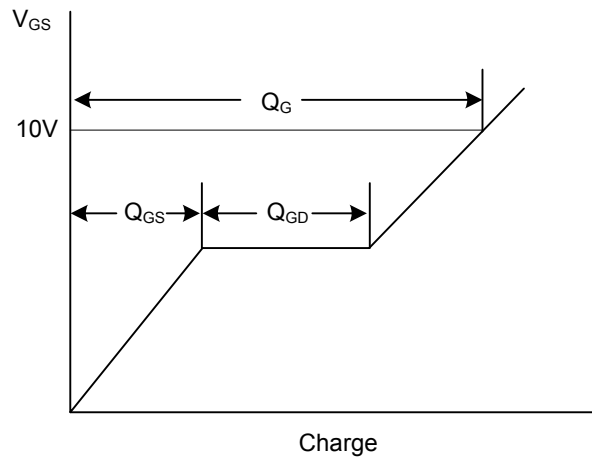

Charge

Gate Charge Waveform

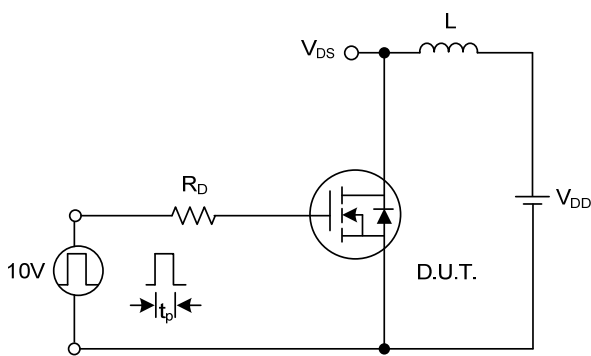

Unclamped Inductive Switching Test Circuit

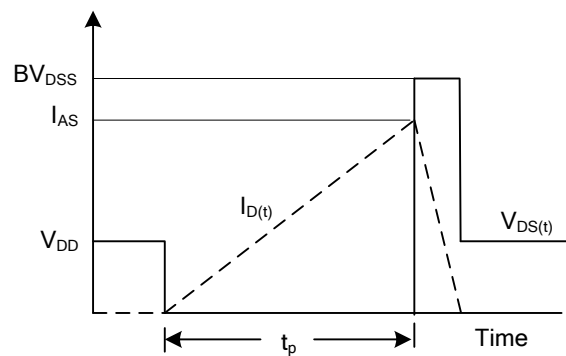

Unclamped Inductive Switching Waveforms

UTC assumes no responsibility for equipment failures that result from using products at values that exceed, even momentarily, rated values (such as maximum ratings, operating condition ranges, or other parameters) listed in products specifications of any and all UTC products described or contained herein. UTC products are not designed for use in life support appliances, devices or systems where malfunction of these products can be reasonably expected to result in personal injury. Reproduction in whole or in part is prohibited without the prior written consent of the copyright owner. The information presented in this document does not form part of any quotation or contract, is believed to be accurate and reliable and may be changed without notice.