

CMOS QUAD 3-STATE R-S LATCHES

FEATURES

- ◆ Separate Set and Reset Inputs for each Latch
- ◆ Active-High (4043 B) or Active-Low (4044 B) Inputs
- ◆ 3-State Outputs with Common Enable

DESCRIPTION

4043B types are Quad cross-coupled 3-state CMOS NOR Latches, and the 4044 B types are Quad cross-coupled 3-state CMOS NAND Latches. Each latch has a separate Q output and individual Set and Reset inputs. The Q outputs are gated through transmission gates controlled by a common Enable input. A logic "1" or "high" on the Enable input connects the latch states to the Q outputs. A logic "0" or "low" on the Enable input disconnects the latch states from the Q outputs, resulting in an open circuit condition on the Q outputs. The open circuit feature allows common bussing of the outputs. The logic operation of the latches is summarized in the truth table below.

TRUTH TABLES

4043 B

S	R	E	Q
X	X	0	OC*
0	0	1	NC+
1	0	1	1
0	1	1	0
1	1	1	Δ

- * OPEN CIRCUIT
- + NO CHANGE
- Δ DOMINATED BY S = 1 INPUT

4044 B

S	R	E	Q
X	X	0	OC*
1	1	1	NC+
0	1	1	1
1	0	1	0
0	0	1	ΔΔ

- * OPEN CIRCUIT
- + NO CHANGE
- ΔΔ DOMINATED BY R = 0 INPUT

CONNECTION DIAGRAMS (all packages)

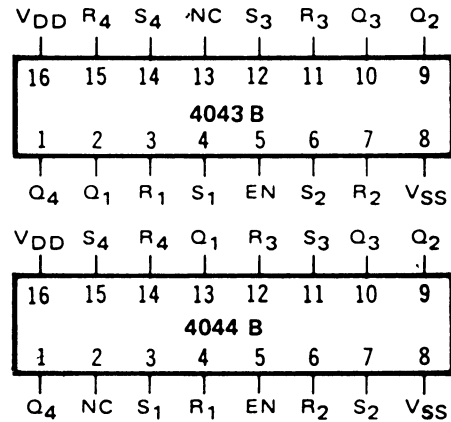

Add suffix for package:

- C 16-pin Cerdip
- E 16-pin Epoxy

RECOMMENDED OPERATING CONDITIONS

For maximum reliability:

DC Supply Voltage $V_{DD} - V_{SS}$ 3 to 15 Vdc

Operating Temperature T_A

C -55 to +125 °C

E -40 to +85 °C

BLOCK DIAGRAMS

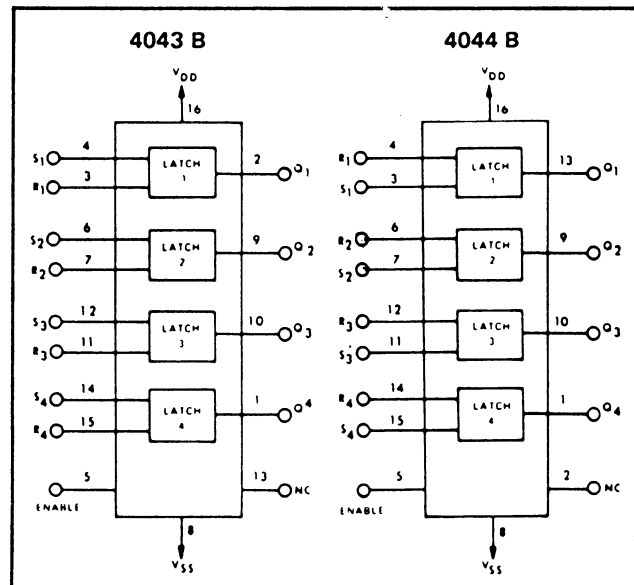

ELECTRICAL CHARACTERISTICS

STATIC CHARACTERISTICS ¹

PARAMETER	V _{DD} (Vdc)	CONDITIONS	T _{LOW} ²		+25°C			T _{HIGH} ²		Units	
			Min.	Max.	Min.	Typ.	Max.	Min.	Max.		
QUIESCENT DEVICE CURRENT	I _{DD}	V _{IN} =V _{SS} or V _{DD} All valid input combinations	-	1.0	-	0.005	1.0	-	30	μAdc	
			-	2.0	-	0.01	2.0	-	60		
			-	4.0	-	0.02	4.0	-	120		
3-STATE OUTPUT LEAKAGE CURRENT	I _{ZL}	15	Enable = V _{SS}	-	±0.1	-	±10 ⁻⁴	±0.1	-	±1.0	μAdc

NOTES: ¹ Remaining Static Electrical Characteristics are listed under "4000B Series Family Specifications".

² T_{LOW} = -55°C for C
 = -40°C for E
 T_{HIGH} = +125°C for C
 = + 85°C for E

DYNAMIC CHARACTERISTICS (C_L = 50pF, T_A = 25°C)

PARAMETER		V _{DD} (Vdc)	Min.	Typ.	Max.	Units
PROPAGATION DELAY TIME From S or R Inputs	t _{PLH} , t _{PHL}	5	-	150	300	ns
		10	-	70	140	
		15	-	50	100	
From Enable Input	t _{PHZ} , t _{PLZ} t _{PZH} , t _{PZL}	5	-	75	150	ns
		10	-	35	70	
		15	-	30	60	
OUTPUT TRANSITION TIME	t _{TLH} , t _{THL}	5	-	100	200	ns
		10	-	50	100	
		15	-	40	80	
MINIMUM SET OR RESET PULSE WIDTH	PW _S , PW _R	5	-	80	160	ns
		10	-	40	80	
		15	-	30	60	
SET OR RESET REMOVAL TIME	t _{rem}	5	-	25	50	ns
		10	-	15	30	
		15	-	10	20	

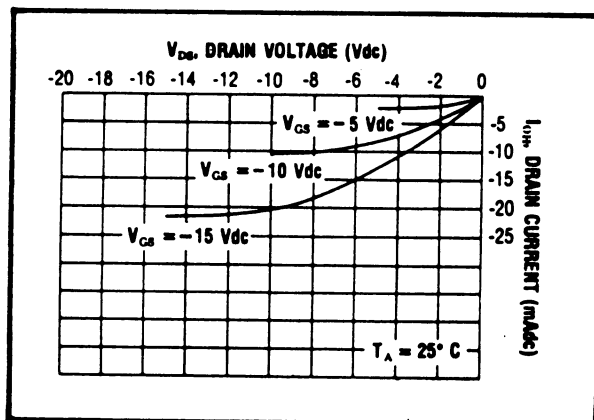

Typical P-Channel Source Current Characteristics

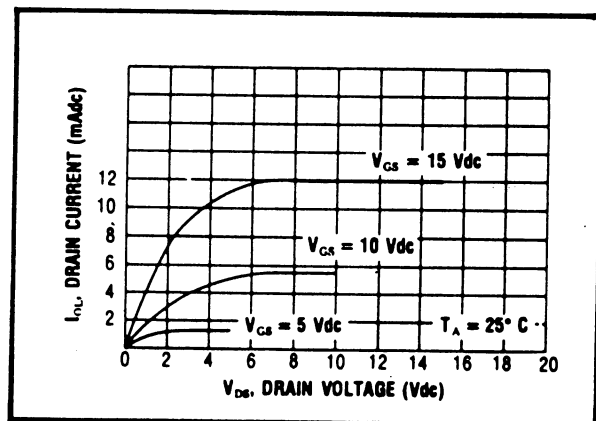

Typical N-Channel Sink Current Characteristics

LOGIC DIAGRAMS

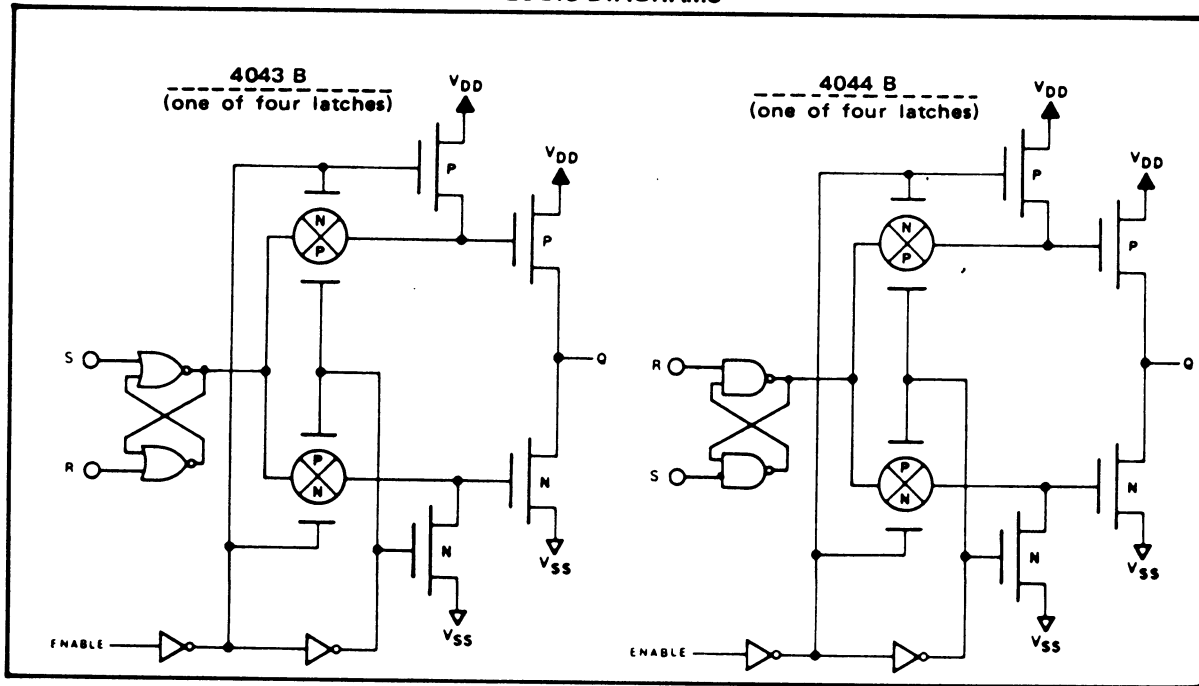

APPLICATIONS INFORMATION

