

**42141 POSITIVE REGULATOR + 5 VOLTS**



**Features:**

- Output noise typically less than 3 $\mu$ v
- Output current up to 150 mA
- Input voltage up to 30V
- Internal short circuit protection, foldback and current limiting

**Applications:**

- Down hole oil exploration
- Military & high reliability applications where a hermetically sealed product for harsh environments is required

**DESCRIPTION**

This regulator is fabricated using hybrid techniques and will operate at temperatures up to 200°C. This device is complete with internal short circuit protection which includes voltage shutdown and current foldback. The new 42141 series regulator normally does not require any additional components. However, for good design practice, an external filter cap should be installed at the input, as close to the case as possible.

**ABSOLUTE MAXIMUM RATINGS AT 200°C**

Output Current (I <sub>OUT</sub> ) .....	150mA
Input Voltage (V <sub>IN</sub> ) .....	+30V <sub>DC</sub>
Operating Temperature (T <sub>C</sub> ).....	200°C
Power Dissipation @ t <sub>A</sub> = 25°C (Pd).....	1.0W

**MECHANICAL CONFIGURATION**

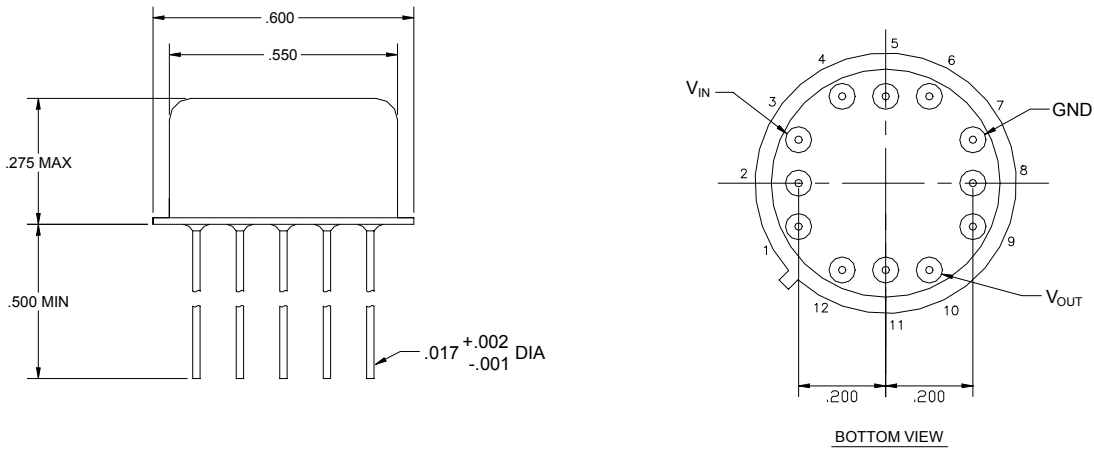

PIN	FUNCTION
3	V <sub>IN</sub>
7	GROUND (COMMON)
10	V <sub>OUT</sub>

Micropac Industries cannot assume any responsibility for any circuits shown or represent that they are free from patent infringement. Micropac reserves the right to make changes at any time in order to improve design and to supply the best product possible.

**ELECTRICAL CHARACTERISTICS**

PARAMETER	TEST CONDITIONS	CASE TEMPERATURE	TYPICAL
Output Voltage	$I_{OUT} = 150 \text{ mA}$ $V_{IN} = V_{OUT} + 3V_{DC}$	0°C to +200°C	$V_{OUT} \pm 1.0\%$
Line Regulation	$V_{IN} = V_{OUT} + 3V_{DC}$ $I_{OUT} = 50 \text{ mA}$	0°C to +200°C	$V_{OUT} \pm 0.3\%$
Load Regulation	$V_{IN} = V_{OUT} + 5V_{DC}$ $I_{OUT} = 50 \text{ to } 150 \text{ mA}$	0°C to +200°C	$V_{OUT} \pm 0.5\%$
Ripple Rejection at 120 Hz	$V_{IN} = V_{OUT} + 5V_{DC}$	+25°C	-55 db
Standby Current	$V_{IN} = V_{OUT} + 5V_{DC}$ $I_{OUT} = 0$	+25°C	20 mA
Short Circuit Current	$V_{IN} = V_{OUT} + 5V_{DC}$	+25°C	150 mA
Foldback Current	$V_{IN} = V_{OUT} + 5V_{DC}$	+25°C	450 mA
Differential Voltage ( $\Delta V = V_{IN} - V_{OUT}$ )	$I_{OUT} = 150 \text{ mA}$	+25°C to +200°C	3V Min.

NOTE: Under condition  $V_{IN} - V_{OUT} \times I_{OUT} \leq 2.0$  watts using EG&G Wakefield Engineering Model 215 Heatsink or 1.5 watts without Heatsink.

**TYPICAL CONNECTION DIAGRAM**

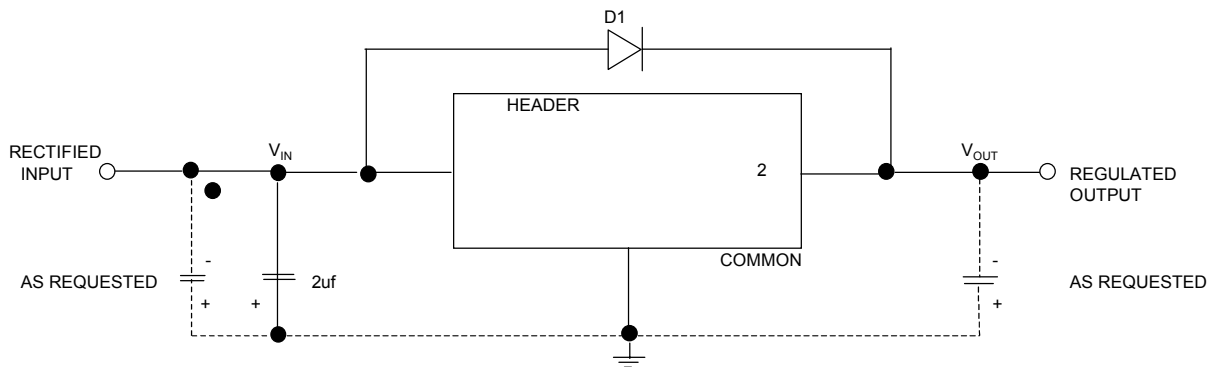

Micropac Industries cannot assume any responsibility for any circuits shown or represent that they are free from patent infringement.  
Micropac reserves the right to make changes at any time in order to improve design and to supply the best product possible.