



HIGH POWER OP-AMP

541 SERIES

4707 Dey Road Liverpool, N.Y. 13088

(315) 701-6751

MIL-PRF-38534 QUALIFIED

FEATURES:

- Available as SMD #5962-8870101
- High Output Current - 10 Amps Peak
- Wide Power Supply Range - $\pm 10V$ to $\pm 40V$
- Programmable Current Limit
- FET Input
- Isolated Case
- Replacement for OMA 541SKB - MSK 541
OMA 541SDB - MSK 146
OMA 541SZB - MSK 147

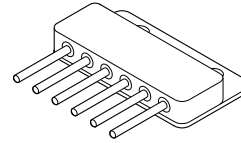

MSK145

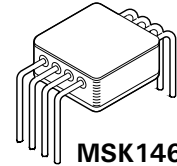

MSK146

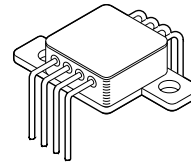

MSK147

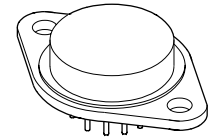

MSK541

DESCRIPTION:

The MSK 541 Series is a high power monolithic amplifier ideally suited for high power amplification and magnetic deflection applications. This amplifier is capable of operation at a supply voltage rating of 80 volts and can deliver guaranteed continuous output currents up to 5A, making the 541 series an excellent low cost choice for motor drive circuits. The amplifier and load can be protected from fault conditions through the use of internal current limit circuitry that can be user programmed with a single external resistor. The MSK 541 is pin compatible with popular op-amps such as the Burr-Brown OPA501, OPA511, OPA512, OPA541 and 3573. The MSK 541 is available in a hermetically sealed 8 pin TO-3 package. Other package styles are also available for a wide range of applications. The MSK 145 is available in a 6 pin SIP Package. The MSK 146 is an 8 pin Power DIP Package and the MSK 147 is available in an 8 pin Power Z-TAB Package for applications requiring bolt down heat sinking.

EQUIVALENT SCHEMATIC

MSK 541 ONLY

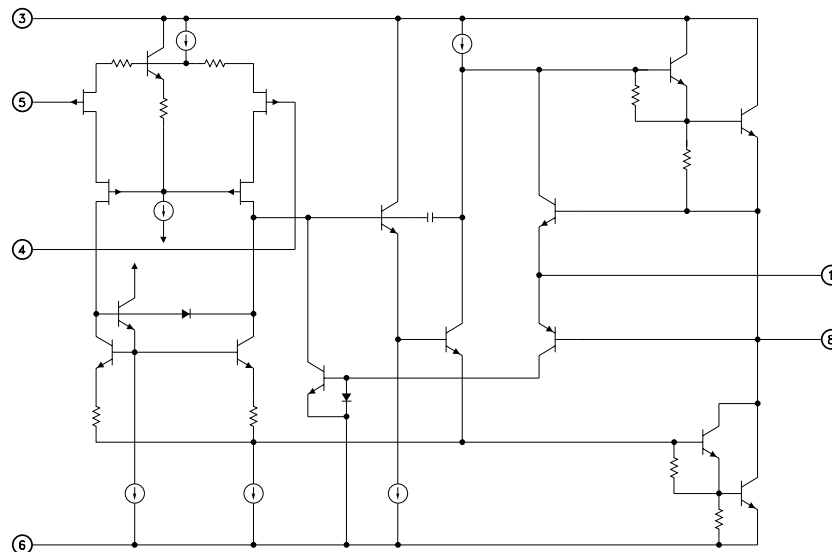

TYPICAL APPLICATIONS

- Servo Amplifier
- Motor Driver
- Audio Amplifier
- Programmable Power Supply

PIN-OUT INFORMATION

- | | |
|-------------------------|-------------------------|
| 1 Current Sense | 5 Inverting Input |
| 2 No Connection | 6 Negative Power Supply |
| 3 Positive Power Supply | 7 No Connection |
| 4 Non-Inverting Input | 8 Output Drive |

The above pin out table is for the MSK 541 (TO-3). Refer to the mechanical specifications page for the pin out information of additional package styles.

ABSOLUTE MAXIMUM RATINGS

$\pm V_{CC}$	Supply Voltage	$\pm 40V$	T_{ST}	Storage Temperature Range	-65° to $+150^{\circ}C$
I_{OUT}	Peak Output Current	See S.O.A.	T_{LD}	Lead Temperature Range	300°
V_{IN}	Differential Input Voltage	$\pm V_{CC}$		(10 Seconds)	
V_{IN}	Common Mode Input Voltage	$\pm V_{CC}$	P_D	Power Dissipation	125W
R_{TH}	Thermal Resistance-Junction to Case		T_J	Junction Temperature	$150^{\circ}C$
	MSK 541	$1.9^{\circ} C/W$	T_C	Case Operating Temperature Range	
	MSK 145	$1.2^{\circ} C/W$		Military Versions	$-55^{\circ}C$ to $+125^{\circ}C$
	MSK 146	$1.2^{\circ} C/W$		Industrial Versions	$-40^{\circ}C$ to $+85^{\circ}C$
	MSK 147	$1.2^{\circ} C/W$			

ELECTRICAL SPECIFICATIONS ^⑨

Parameter	Test Conditions	Group A Subgroup	Military			Industrial ^⑤			Units
			Min.	Typ.	Max.	Min.	Typ.	Max.	
STATIC									
Supply Voltage Range ^② ^④		-	± 10	± 35	± 40	± 10	± 35	± 40	V
Quiescent Current	$V_{IN} = 0V$	1, 2, 3	-	± 20	± 30	-	± 20	± 35	mA
INPUT									
Input Offset Voltage	$V_{IN} = 0V$	1	-	± 0.1	± 1.0	-	± 1.0	± 10	mV
Input Offset Voltage Drift	$V_{IN} = 0V$	2, 3	-	± 15	± 50	-	± 15	-	$\mu V/^{\circ}C$
Input Bias Current ^④	$V_{CM} = 0V$ Either Input	1	-	± 4	± 50	-	± 4	± 100	pA
		2, 3	-	± 0.2	± 10	-	± 0.2	-	nA
Input Offset Current ^④	$V_{CM} = 0V$	1	-	2.0	30	-	2.0	30	pA
		2, 3	-	-	20	-	-	-	nA
Input Capacitance		-	-	5	-	-	5	-	pF
Input Impedance	$F = DC$	-	-	10^{12}	-	-	10^{12}	-	W
Common Mode Rejection Ratio ^④	$F = DC$ $V_{CM} = \pm 22V$	-	95	113	-	90	113	-	dB
Power Supply Rejection Ratio	$V_{CC} = \pm 10V$ to $\pm 40V$	-	-	90	-	-	90	-	dB
Input Noise Voltage	$F = 10$ Hz to 1 KHz	-	-	10	-	-	10	-	$\mu VRMS$
OUTPUT									
Output Voltage Swing	$R_L = 5.6\Omega$ $F = 10$ KHz	4	± 28	± 29	-	± 28	± 29	-	V
	$R_L = 10\Omega$ $F = 10$ KHz	5, 6	± 30	± 31	-	-	-	-	V
Output Current	$R_L = 5.6\Omega$ $F = 10$ KHz	4	± 5	± 8	-	± 5	± 8	-	A
	$R_L = 10\Omega$ $F = 10$ KHz	5, 6	± 3.0	-	-	-	-	-	A
Settling Time ^③	0.1% 2V step	-	-	2	-	-	2	-	μS
Power Bandwidth ^④	$R_L = 10\Omega$ $V_O = 20$ VRMS	4	45	55	-	40	50	-	KHz
TRANSFER CHARACTERISTICS									
Slew Rate	$V_{OUT} = \pm 10V$ $R_L = 10\Omega$	4	6	10	-	6	10	-	$V/\mu S$
Open Loop Voltage Gain ^④	$F = 10$ Hz $R_L = 10$ K Ω	4	95	100	-	90	100	-	dB
		5, 6	85	-	-	-	-	-	dB

NOTES:

- ① Unless otherwise specified $R_{CL} = 0\Omega$, $\pm V_{CC} = \pm 34$ VDC
- ② Electrical specifications are derated for power supply voltages other than ± 34 VDC.
- ③ $A_V = -1$, measured in false summing junction circuit.
- ④ Devices shall be capable of meeting the parameter, but need not be tested. Typical parameters are for reference only.
- ⑤ Industrial grade devices shall be tested to subgroups 1 and 4 unless otherwise specified.
- ⑥ Military grade devices ('B' suffix) shall be 100% tested to subgroups 1, 2, 3 and 4.
- ⑦ Subgroup 5 and 6 testing available upon request.
- ⑧ Subgroup 1, 4 $T_A = T_C = +25^{\circ}C$
Subgroup 2, 5 $T_A = T_C = +125^{\circ}C$
Subgroup 3, 6 $T_A = T_C = -55^{\circ}C$
- ⑨ Reference DSCC SMD 5962-8870101 for electrical specifications for devices purchased as such.

APPLICATION NOTES

HEAT SINKING

To select the correct heat sink for your application, refer to the thermal model and governing equation below.

Thermal Model:

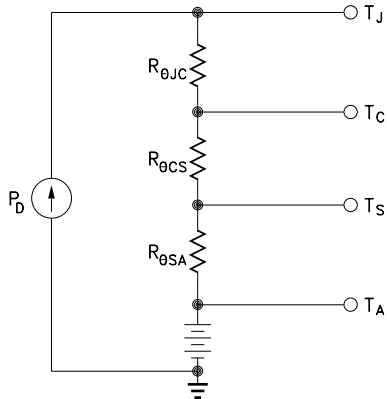

Governing Equation:

$$T_J = P_D \times (R_{\theta JC} + R_{\theta CS} + R_{\theta SA}) + T_A$$

Where

T_J	=	Junction Temperature
P_D	=	Total Power Dissipation
$R_{\theta JC}$	=	Junction to Case Thermal Resistance
$R_{\theta CS}$	=	Case to Heat Sink Thermal Resistance
$R_{\theta SA}$	=	Heat Sink to Ambient Thermal Resistance
T_C	=	Case Temperature
T_A	=	Ambient Temperature
T_S	=	Sink Temperature

Example: (TO-3 PACKAGE)

In our example the amplifier application requires the output to drive a 20 volt peak sine wave across a 5 ohm load for 4 amps of output current. For a worst case analysis we will treat the 4 amps peak output current as a D.C. output current. The power supplies are ± 35 VDC.

1.) Find Power Dissipation

$$\begin{aligned} P_D &= [(quiescent\ current) \times (+V_{CC} - (V_{CC}))] + [(V_S - V_O) \times I_{OUT}] \\ &= (30\ mA) \times (70V) + (15V) \times (4A) \\ &= 2.1W + 60W \\ &= 62.1W \end{aligned}$$

2.) For conservative design, set $T_J = +150^\circ C$

3.) For this example, worst case $T_A = +25^\circ C$

4.) $R_{\theta JC} = 1.2^\circ C/W$ typically for the TO-3 package

5.) $R_{\theta CS} = 0.15^\circ C/W$ for most thermal greases

6.) Rearrange governing equation to solve for $R_{\theta SA}$

$$\begin{aligned} R_{\theta SA} &= (T_J - T_A) / P_D - (R_{\theta JC}) - (R_{\theta CS}) \\ &= (150^\circ C - 25^\circ C) / 62.1W - (1.2^\circ C/W) - (0.15^\circ C/W) \\ &= 0.66^\circ C/W \end{aligned}$$

The heat sink in this example must have a thermal resistance of no more than $0.66^\circ C/W$ to maintain a junction temperature of no more than $+150^\circ C$. Since this value of thermal resistance may be difficult to find, other measures may have to be taken to decrease the overall power dissipation.

CURRENT LIMIT

The MSK 541 has an on-board current limit scheme designed to limit the output drivers anytime output current exceeds a predetermined limit. The following formula may be used to determine the value of the current limit resistance necessary to establish the desired current limit.

$$R_{CL} (\text{OHMS}) = (0.809 \text{ volts} / \text{current limit in amps}) - 0.057 \text{ OHM}$$

The 0.057 OHM term takes into account any wire bond and lead resistance. Since the 0.809 volt term is obtained from the base emitter voltage drop of a bipolar transistor, the equation only holds true for operation at $+25^\circ C$ case temperature. The effect that temperature has on current limit may be seen on the Current Limit vs. Case Temperature Curve in the Typical Performance Curves.

Current Limit Connection

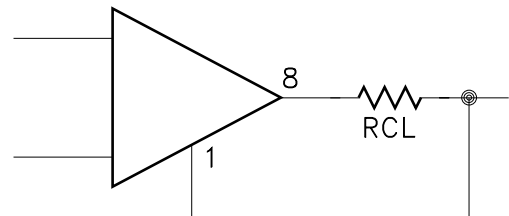

See "Application Circuits" in this data sheet for additional information on current limit connections.

POWER SUPPLY BYPASSING

Both the negative and the positive power supplies must be effectively decoupled with a high and low frequency bypass circuit to avoid power supply induced oscillation. An effective decoupling scheme consists of a 0.1 microfarad ceramic capacitor in parallel with a 4.7 microfarad tantalum capacitor from each power supply pin to ground. It is also a good practice with very high power op-amps, such as the MSK 541, to place a 30-50 microfarad nonelectrolytic capacitor with a low effective series resistance in parallel with the other two power supply decoupling capacitors. This capacitor will eliminate any peak output voltage clipping which may occur due to poor power supply load regulation. All power supply decoupling capacitors should be placed as close to the package power supply pins as possible (pins 3 and 6 for the MSK 541).

SAFE OPERATING AREA

The safe operating area curve is a graphical representation of the power handling capability of the amplifier under various conditions. The wire bond current carrying capability, transistor junction temperature and secondary breakdown limitations are all incorporated into the safe operating area curves. All applications should be checked against the S.O.A. curves to ensure high M.T.B.F.

APPLICATION CIRCUITS

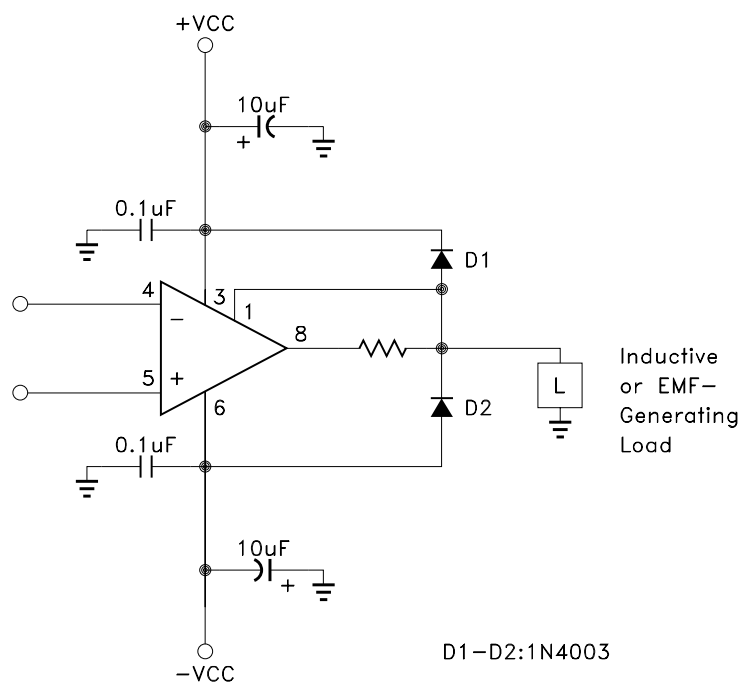

Clamping Output for EMF-Generating Loads

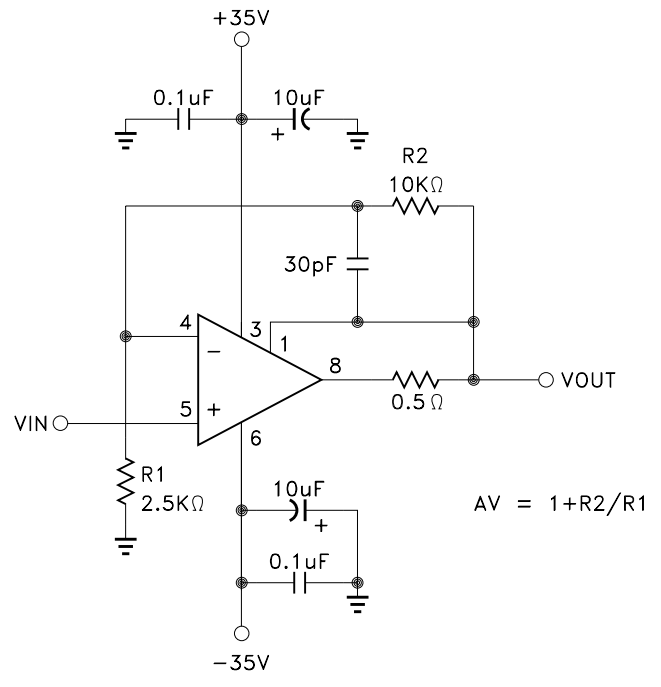

Isolating Capacitive Loads

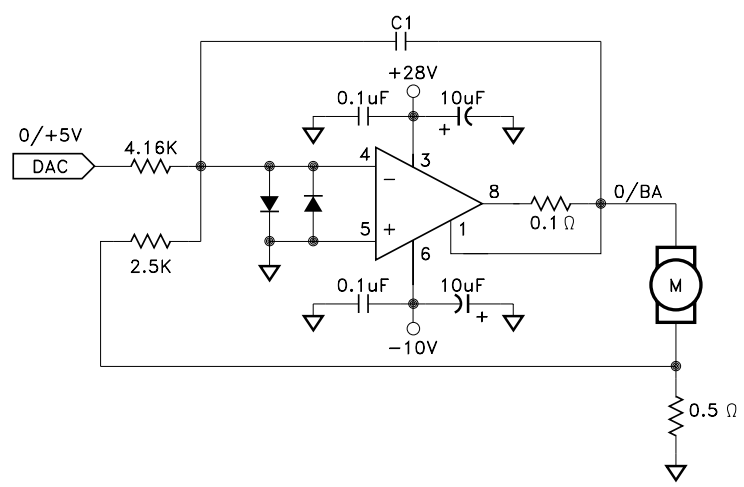

**Motor Current a Function of VIN
Programmable Torque Circuit**

The linear relationship of torque output to current input of the modern torque motor makes this simple control circuit ideal for many material processing and testing applications. The sense resistor develops a feedback voltage proportional to motor current and the small signal properties of the Power Op Amp insure accuracy. With this closed loop operation, temperature induced impedance variations of the motor winding are automatically compensated.

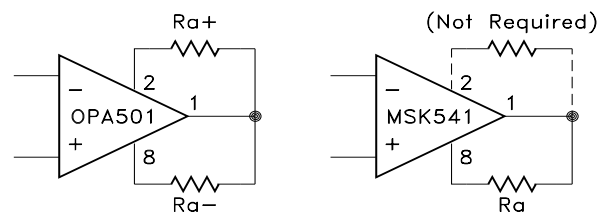

Replacing OPA501 with MSK 541

When replacing the OPA501, OPA511, OPA512 or 3573 with the MSK 541, it is not necessary to make any changes in the current limit scheme. Since pin 2 is not connected in the MSK 541, the current limit resistor connected from pin 1 to pin 2 can be left in the circuit or removed.

TYPICAL PERFORMANCE CURVES

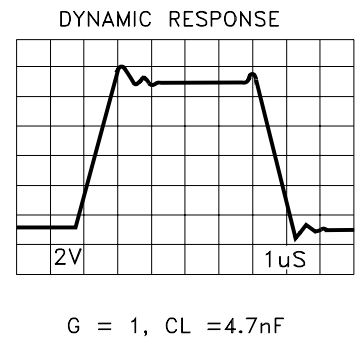
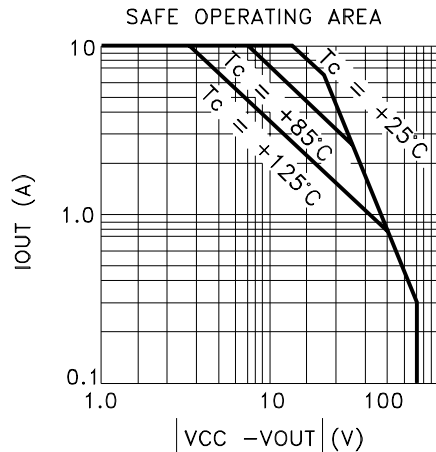
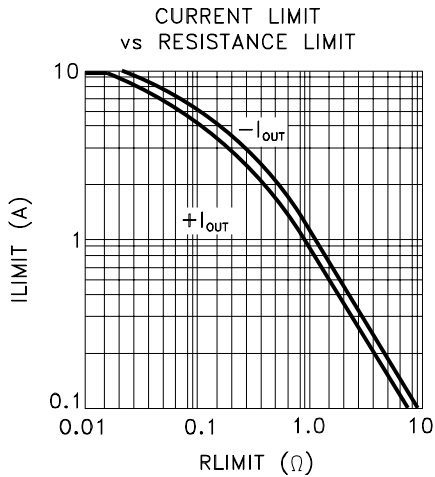
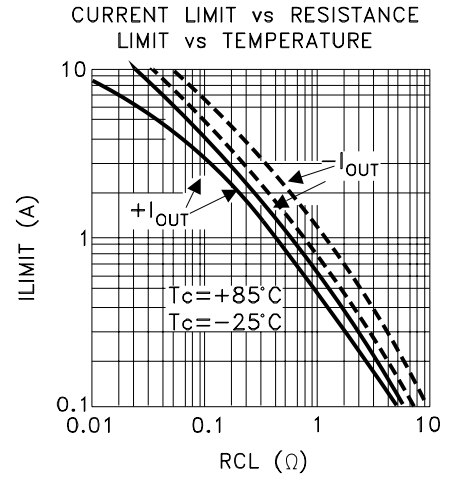
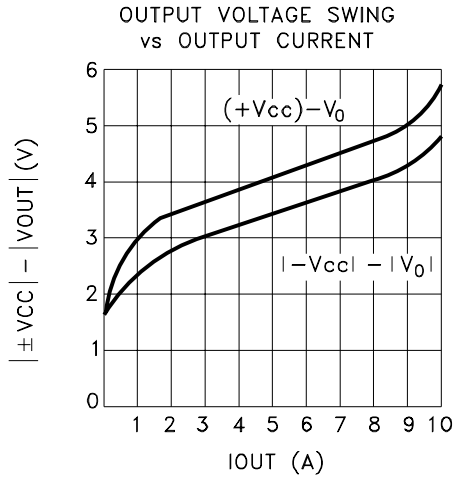
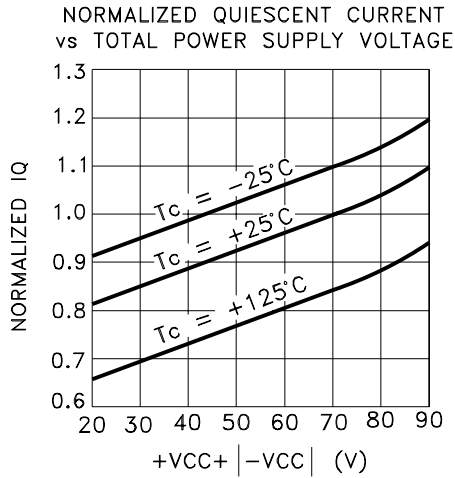
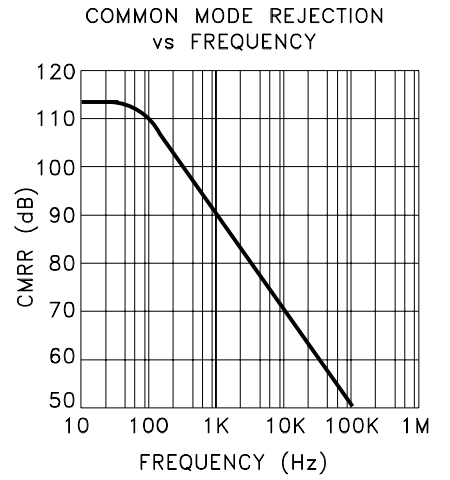
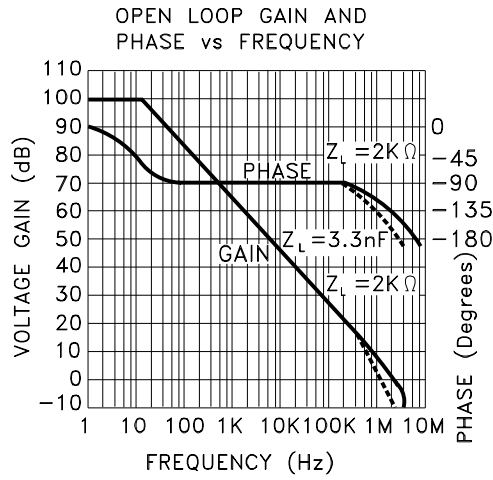
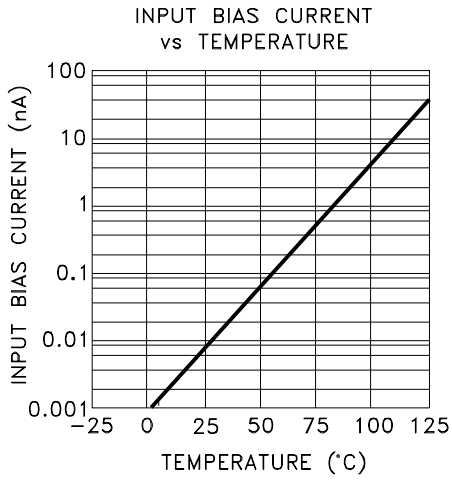

MECHANICAL SPECIFICATIONS

MSK145

POWER SIP PACKAGE

ORDERING INFORMATION

PART NO.	SCREENING LEVEL
MSK145	INDUSTRIAL
MSK145B	MIL-PRF-38534
5962-8870101Z	DSCC-SMD

PIN NO.	FUNCTION
1	-VCC
2	OUTPUT DRIVE
3	CURRENT SENSE
4	+VCC
5	+INPUT
6	-INPUT

ALL DIMENSIONS ARE ±0.01 INCHES UNLESS OTHERWISE SPECIFIED ESD TRIANGLE INDICATES PIN 1

MSK146

POWER DIP PACKAGE

ORDERING INFORMATION

PART NO.	SCREENING LEVEL
MSK146	INDUSTRIAL
MSK146B	MIL-PRF-38534
5962-8870101Y	DSCC-SMD

PIN NO.	FUNCTION
1	-VCC
2	N/C
3	OUTPUT DRIVE
4	CURRENT SENSE
5	+VCC
6	N/C
7	+INPUT
8	-INPUT

MSK147

POWER Z-TAB PACKAGE

ORDERING INFORMATION

PART NO.	SCREENING LEVEL
MSK147	INDUSTRIAL
MSK147B	MIL-PRF-38534
5962-8870101U	DSCC-SMD

PIN NO.	FUNCTION
1	-VCC
2	N/C
3	OUTPUT DRIVE
4	CURRENT SENSE
5	+VCC
6	N/C
7	+INPUT
8	-INPUT

MECHANICAL SPECIFICATIONS CONTINUED

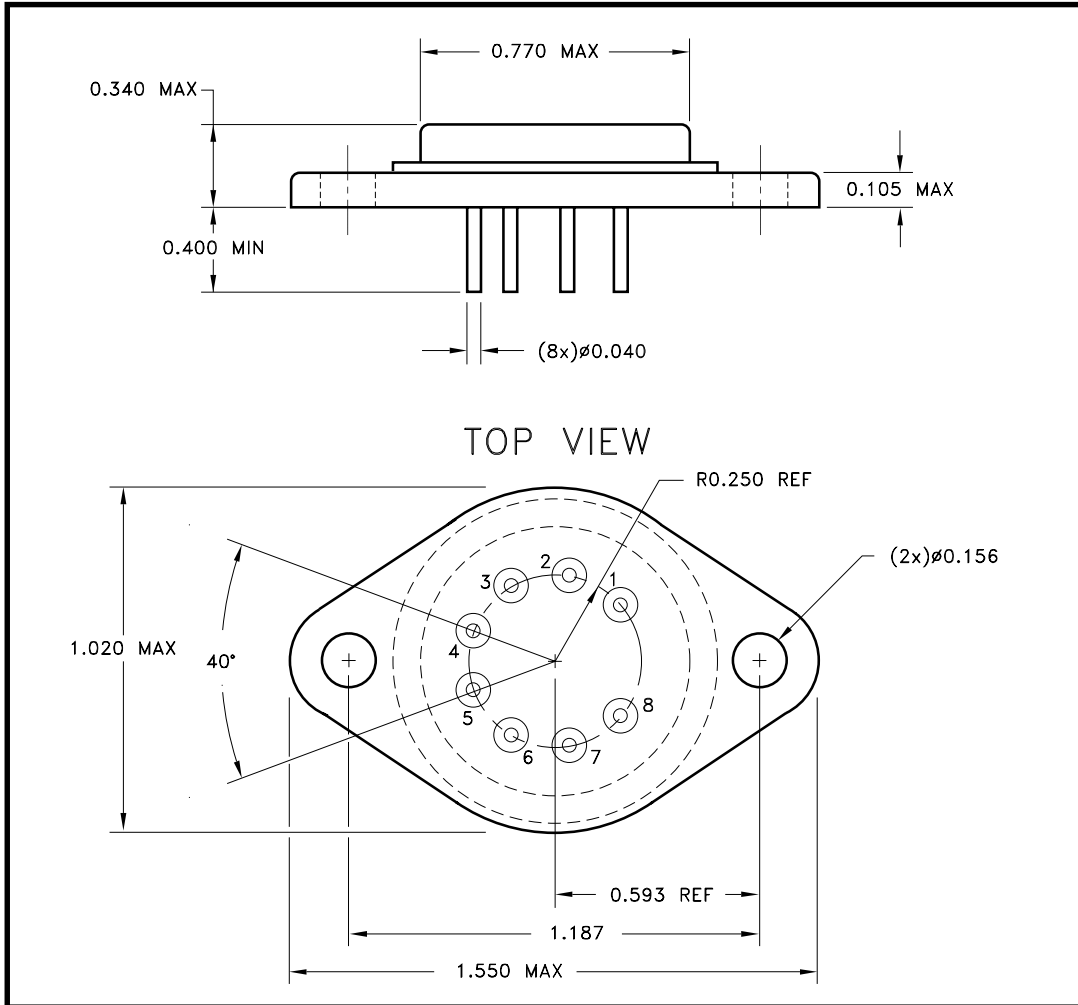

ALL DIMENSIONS ARE ± 0.010 INCHES UNLESS OTHERWISE SPECIFIED

ORDERING INFORMATION

Part Number	Screening Level
MSK 541	Industrial
MSK 541 B	Military - MIL-PRF-38534
5962-8870101X	DSCC - SMD

M.S. Kennedy Corp.
 4707 Dey Road, Liverpool, New York 13088
 Phone (315) 701-6751
 Fax (315) 701-6752
 www.mskennedy.com

The information contained herein is believed to be accurate at the time of printing. MSK reserves the right to make changes to its products or specifications without notice, however and assumes no liability for the use of its products. Please visit our website for the most recent revision of this datasheet