

FEATURES

- The plastic package carries Underwrites Laboratory
- Flammability Classification 94V-0
- High forward current capability
- High surge current capability
- Construction utilizes void-free molded plastic technique
- High temperature soldering guaranteed:260°C/10 seconds at terminals
- Component in accordance to RoHS 2011/65/EU

MECHANICAL DATA

- Case: JEDEC DO-201AD molded plastic body
- Terminals: Plated axial leads, solderable per MIL-STD-750,method 2026
- Polarity: Color band denotes cathode end
- Mounting Position: Any
- Weight: 0.041ounce, 1.15 grams

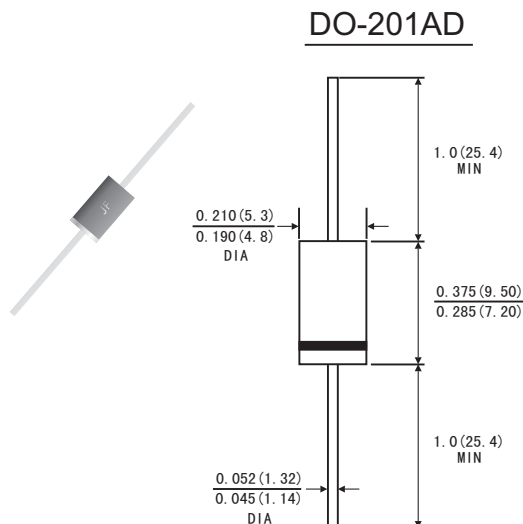

MAXIMUM RATINGS AND ELECTRICAL CHARACTERISTICS

Dimensions in inches and (millimeters)

(Ratings at 25°C ambient temperature unless otherwise specified ,Single phase ,half wave 60Hz,,resistive or inductive load. For capacitive load, derate by 20%.)

	Symbols	6A05G	6A1G	6A2G	6A3G	6A4G	6A6G	6A8G	6A10G	Unis
Maximum recurrent peak reverse voltage	V _{RRM}	50	100	200	300	400	600	800	1000	Volts
Maximum RMS voltage	V _{RMS}	35	70	140	210	280	420	560	700	Volts
Maximum DC blocking voltage	V _{DC}	50	100	200	300	400	600	800	1000	Volts
Maximum average forward rectified current	I(AV)	6.0								Amps
Peak forward surge current (8.3ms half sine-wave superimposed on rated load (JEDEC method)	I _{FSM}	250.0								Amps
Maximum instantaneous forward voltage at 6.0 A	V _F	1.1								Volts
Maximum reverse current at rated DC blocking voltage	T _a =25°C	10.0								μA
	T _a =100°C	250.0								
Maximum Full Load Reverse Current, Full Cycle Average .375" (9.5mm) Lead Length @T _a =75°C	HTIR	5.0								μA
Typical thermal resistance (Note 2)	R _{θJA}	35.0								°C/W
Typical junction capacitance (Note 1)	C _J	90								pF
Operating and Storage temperature range	T _J	-55 to +150								°C
	T _{STG}									

Note: 1.Measured at 1MHz and applied reverse voltage of 4.0V D. C .

2.Mounton Cu-Pad Size 16mm 16mm on P. C. B.

RATINGS AND CHARACTERISTIC CURVES 6A05G THRU 6A10G

FIG.1-FORWARD CURRENT DERATING CURVE

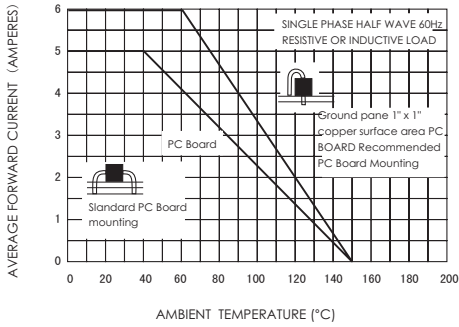

FIG.2-TYPICAL INSTANTANEOUS FORWARD CHARACTERISTICS

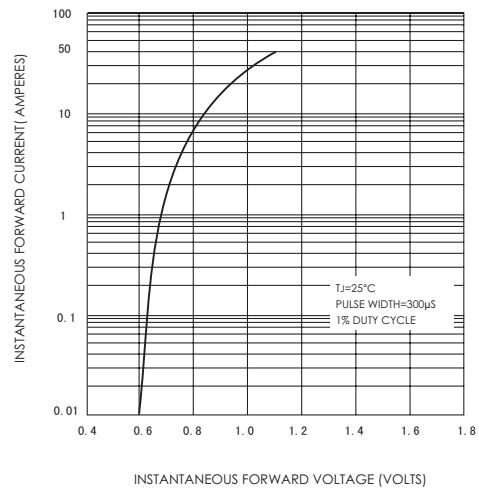

FIG.3-MAXIMUM NON-REPETITIVE PEAK FORWARD SURGE CURRENT

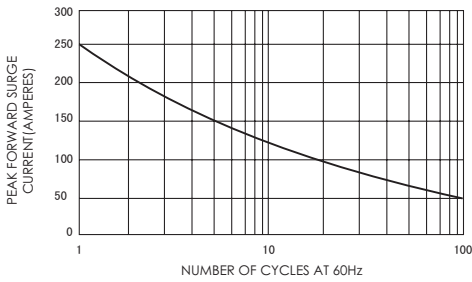

FIG.4-TYPICAL REVERSE CHARACTERISTICS

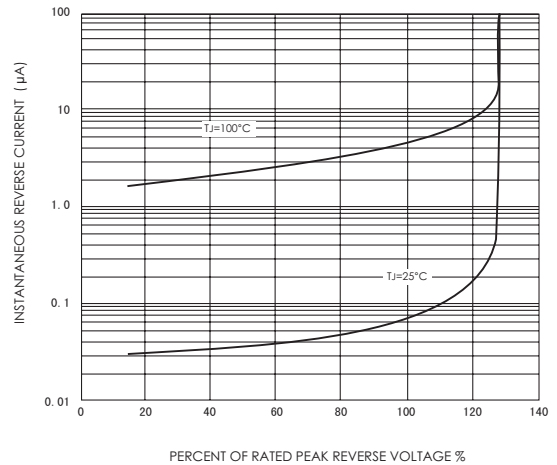

FIG.5-TYPICAL JUNCTION CAPACITANCE

