

DATA SHEET

74F827

10-bit buffer/line driver, non-inverting
(3-State)

74F828

10-bit buffer/line driver, inverting
(3-State)

Product specification

1994 Dec 5

IC15 Data Handbook

Philips Semiconductors



PHILIPS

Buffers

74F827, 74F828

74F827 10-bit buffer/line driver, non-inverting (3-State)
74F828 10-bit buffer/line driver, inverting (3-State)

FEATURES

- High impedance NPN base inputs for reduced loading (20µA in High and Low states)
- I_{IL} is 20µA vs FAST family spec of 600µA and 1000µA for AMD 29827/29828 series
- Ideal where high speed, light bus loading and increased fan-in are required
- Controlled rise and fall times to minimize ground bounce
- Glitch free power-up in 3-State
- Flow through pinout architecture for microprocessor oriented applications
- Outputs sink 64mA
- 74F827 available in SSOP type II package

DESCRIPTION

The 74F827 and 74F828 10-Bit buffers provide high performance bus interface buffering for wide data/address paths or buses carrying parity. They have NOR Output Enables ($\overline{OE}0$, $\overline{OE}1$) for maximum control flexibility.

The 74F827 and 74F828 are functionally and pin compatible to AMD AM29827 and AM29828. The 74F828 is an inverting version of 74F827.

TYPE	TYPICAL PROPAGATION DELAY	TYPICAL SUPPLY CURRENT (TOTAL)
74F827	6.0ns	60mA
74F828	6.0ns	55mA

ORDERING INFORMATION

PACKAGES	COMMERCIAL RANGE $V_{CC} = 5V \pm 10\%$; $T_A = 0^\circ C$ to $+70^\circ C$	DRAWING NUMBER
24-Pin Plastic DIP (300 mil)	N74F827N, N74F828N	SOT222-1
24-Pin Plastic SOL	N74F827D, N74F828D	SOT137-1
24-Pin Plastic SSOP Type II	N74F827DB	SOT340-1

INPUT AND OUTPUT LOADING AND FAN-OUT TABLE

PINS	DESCRIPTION	74F(U.L.) HIGH/LOW	LOAD VALUE HIGH/LOW
D0-D9	Data inputs	1.0/0.033	20µA/20µA
$\overline{OE}0$ - $\overline{OE}1$	Output enable inputs (active Low)	1.0/0.033	20µA/20µA
Q0-Q9	Data outputs (74F827)	1200/106.7	24mA/64mA
$\overline{Q}0$ - $\overline{Q}9$	Data outputs (74F828)	1200/106.7	24mA/64mA

NOTES:

One (1.0) FAST Unit Load is defined as: 20µA in the High state and 0.6 mA in the Low state.

Buffers

74F827, 74F828

PIN CONFIGURATION - 74F827

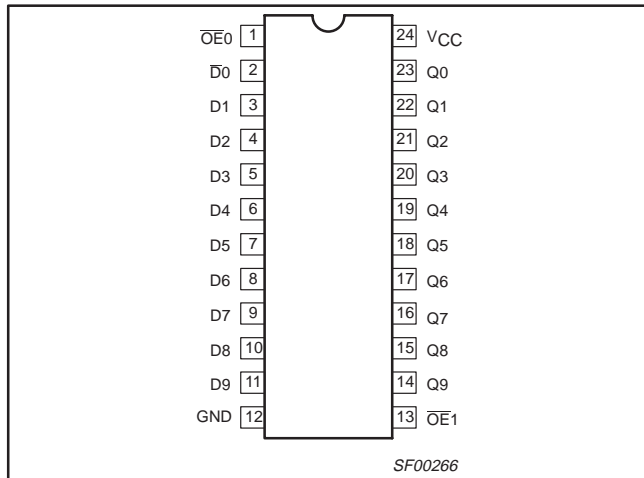

PIN CONFIGURATION - 74F828

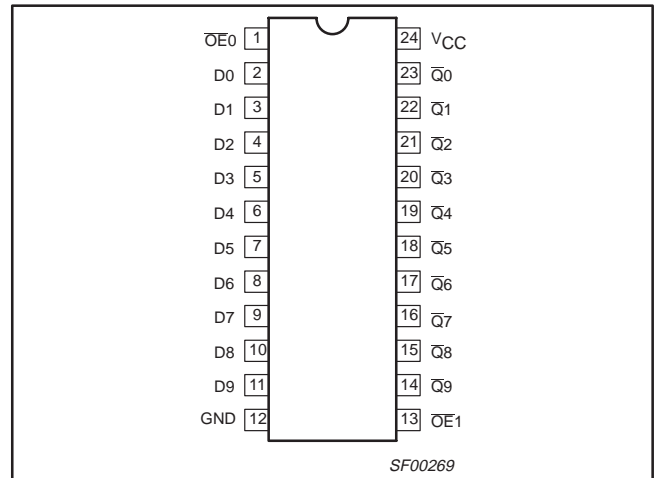

LOGIC SYMBOL - 74F827

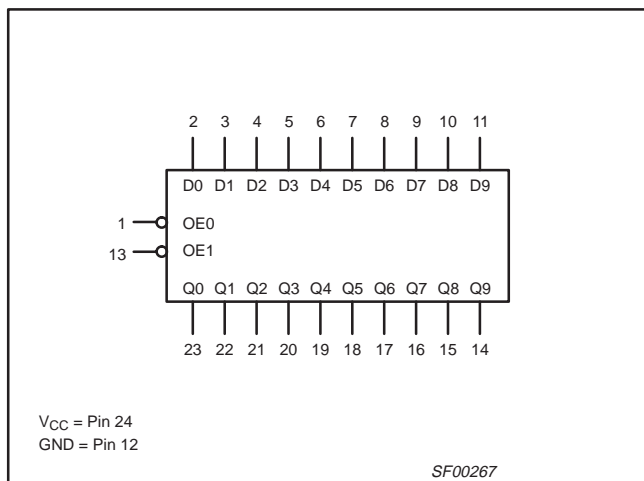

LOGIC SYMBOL - 74F828

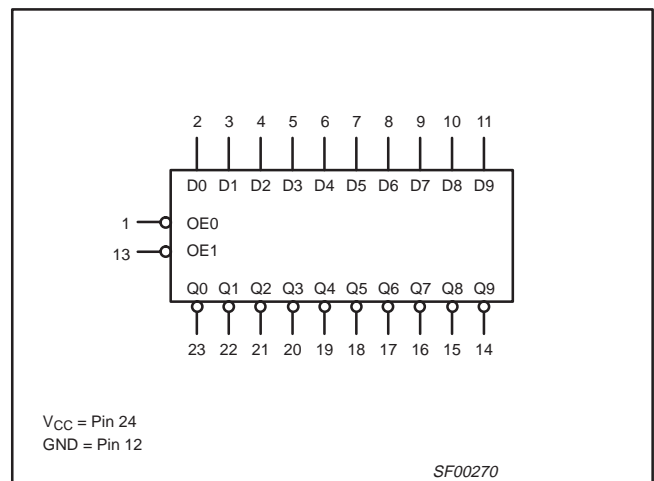

LOGIC SYMBOL (IEEE/IEC) - 74F827

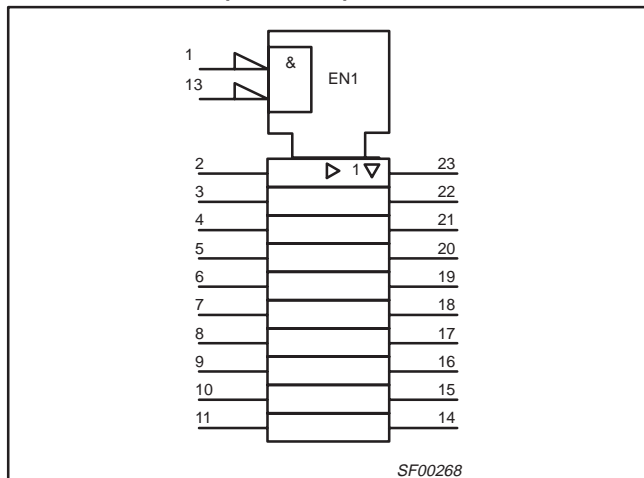

LOGIC SYMBOL (IEEE/IEC) - 74F828

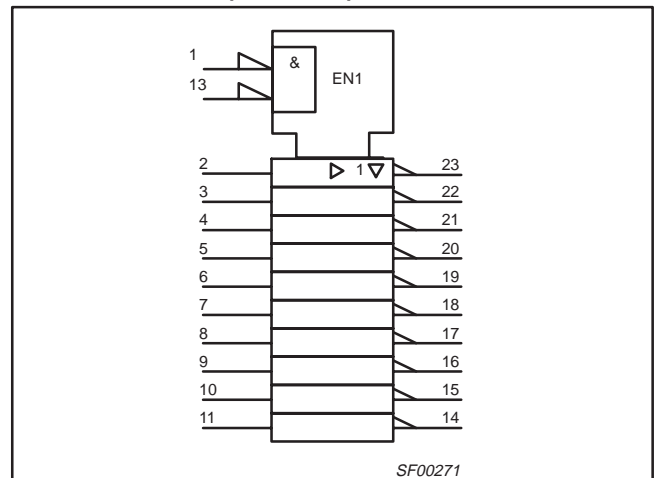

Buffers

74F827, 74F828

LOGIC DIAGRAM 74F827

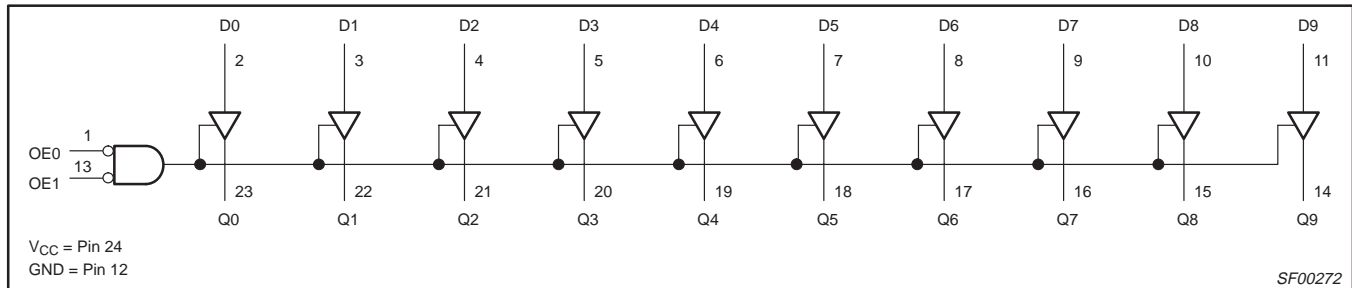

LOGIC DIAGRAM 74F828

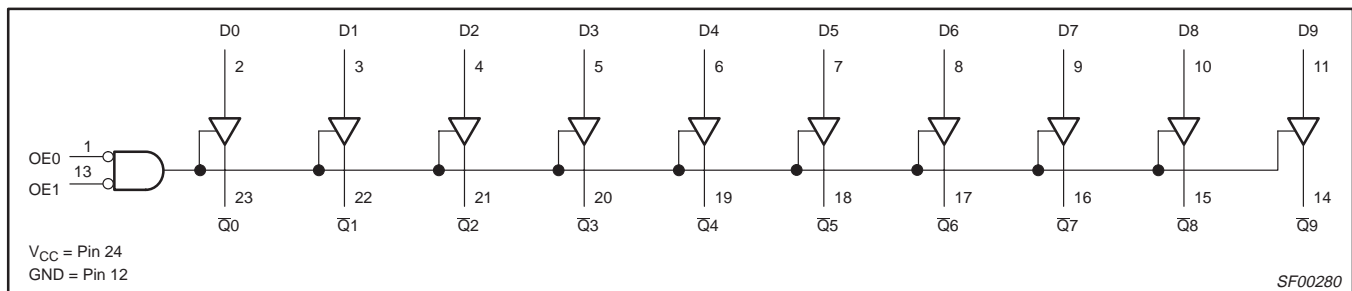

FUNCTION TABLE

INPUTS		OUTPUTS		OPERATING MODE
		74F827	74F828	
OE _n	D _n	Q _n	Q̄ _n	
L	L	L	H	Transparent
L	H	H	L	Transparent
H	X	Z	Z	High impedance

H = High voltage level
 L = Low voltage level
 X = Don't care
 Z = High impedance "off" state

ABSOLUTE MAXIMUM RATINGS

Operation beyond the limits set forth in this table may impair the useful life of the device. Unless otherwise noted these limits are over the operating free-air temperature range.

SYMBOL	PARAMETER	RATING	UNIT
V _{CC}	Supply voltage	-0.5 to +7.0	V
V _{IN}	Input voltage	-0.5 to +7.0	V
I _{IN}	Input current	-30 to +5	mA
V _{OUT}	Voltage applied to output in High output state	-0.5 to +V _{CC}	V
I _{OUT}	Current applied to output in Low output state	128	mA
T _A	Operating free-air temperature range	0 to +70	°C
T _{stg}	Storage temperature range	-65 to +150	°C

Buffers

74F827, 74F828

RECOMMENDED OPERATING CONDITIONS

SYMBOL	PARAMETER	LIMITS			UNIT
		Min	Nom	Max	
V_{CC}	Supply voltage	4.5	5.0	5.5	V
V_{IH}	High-level input voltage	2.0			V
V_{IL}	Low-level input voltage			0.8	V
I_{IK}	Input clamp current			-18	mA
I_{OH}	High-level output current			-24	mA
I_{OL}	Low-level output current			64	mA
T_{amb}	Operating free-air temperature range	0		+70	°C

DC ELECTRICAL CHARACTERISTICS

Over recommended operating free-air temperature range unless otherwise noted.

SYMBOL	PARAMETER	TEST CONDITIONS ¹		LIMITS			UNIT	
				MIN	TYP ²	MAX		
V_{OH}	High-level output voltage	$V_{CC} = \text{MIN}, V_{IL} = \text{MAX}, V_{IH} = \text{MIN}$	$I_{OH} = -15\text{mA}$	$\pm 10\%V_{CC}$	2.4		V	
				$\pm 5\%V_{CC}$	2.4	3.3	V	
		$V_{CC} = \text{MIN}, V_{IL} = \text{MAX}, V_{IH} = \text{MIN}$	$I_{OH} = -24\text{mA}$	$\pm 10\%V_{CC}$	2.0		V	
				$\pm 5\%V_{CC}$	2.0		V	
V_{OL}	Low-level output voltage	$V_{CC} = \text{MIN}, V_{IL} = \text{MAX}, V_{IH} = \text{MIN}$	$I_{OL} = \text{MAX}$	$\pm 10\%V_{CC}$		0.55	V	
				$\pm 5\%V_{CC}$		0.42	0.55	V
V_{IK}	Input clamp voltage	$V_{CC} = \text{MIN}, I_I = I_{IK}$			-0.73	-1.2	V	
I_I	Input current at maximum input voltage	$V_{CC} = 0.0\text{V}, V_I = 7.0\text{V}$				100	μA	
I_{IH}	High-level input current	$V_{CC} = \text{MAX}, V_I = 2.7\text{V}$				20	μA	
I_{IL}	Low-level input current	$V_{CC} = \text{MAX}, V_I = 0.5\text{V}$				-20	μA	
I_{OZH}	Off-state output current, High voltage applied	$V_{CC} = \text{MAX}, V_O = 2.7\text{V}$				50	μA	
I_{OZL}	Off-state output current, Low voltage applied	$V_{CC} = \text{MAX}, V_O = 0.5\text{V}$				-50	μA	
I_{OS}	Short circuit output current ³	$V_{CC} = \text{MAX}$		-100		-225	mA	
I_{CC}	Supply current (total)	74F827	I_{CCH}	$V_{CC} = \text{MAX}$		50	70	mA
			I_{CCL}			70	100	mA
			I_{CCZ}			60	90	mA
		74F828	I_{CCH}			30	45	mA
			I_{CCL}			65	85	mA
			I_{CCZ}			55	70	mA

NOTES:

- For conditions shown as MIN or MAX, use the appropriate value specified under operating conditions for the applicable type.
- All typical values are at $V_{CC} = 5\text{V}, T_A = 25^\circ\text{C}$.
- Not more than one output should be shorted at one time. For testing I_{OS} , the use of high-speed test apparatus and/or sample-and-hold techniques are preferable in order to minimize internal heating and more accurately reflect operational values. Otherwise, prolonged shorting of a High output may raise the chip temperature well above normal and thereby cause invalid readings in other parameter tests. In any sequence of parameter tests, I_{OS} tests should be performed last.

Buffers

74F827, 74F828

AC CHARACTERISTICS

SYMBOL	PARAMETER			LIMITS					UNIT
				T _{amb} = +25°C V _{CC} = 5V C _L = 50pF R _L = 500Ω			T _{amb} = 0 °C to +70°C V _{CC} = 5V ±10% C _L = 50pF R _L = 500Ω		
				Min	Typ	Max	Min	Max	
t _{PLH} t _{PHL}	Propagation delay D _n to Q _n	74F827	Waveform 1	2.0 2.0	5.5 4.5	8.5 8.5	2.0 2.0	9.0 9.0	ns
t _{PZH} t _{PZL}			Output enable time OE _n to Q _n	Waveform 3 Waveform 4	5.0 4.0	8.0 6.0	12.0 10.5	4.5 4.0	
t _{PHZ} t _{PLZ}	Output disable time OE _n to Q _n		Waveform 3 Waveform 4	2.5 2.5	5.0 5.0	8.0 8.0	2.0 2.0	8.5 8.5	ns
t _{PLH} t _{PHL}	Propagation delay D _n to Q _n	74F828	Waveform 2	2.0 1.0	6.0 3.0	8.5 7.0	2.0 1.0	9.5 8.0	
t _{PZH} t _{PZL}			Output enable time OE _n to Q _n	Waveform 3 Waveform 4	6.0 5.0	8.0 7.0	11.5 10.5	5.5 4.5	14.0 12.0
t _{PHZ} t _{PLZ}	Output disable time OE _n to Q _n		Waveform 3 Waveform 4	2.5 1.5	5.0 4.0	8.5 7.0	2.0 1.5	9.0 8.0	ns

AC CHARACTERISTICS

for 1 Output switching with C_L = 300pF and R_L = 500Ω load

SYMBOL	PARAMETER			LIMITS					UNIT
				T _{amb} = +25°C V _{CC} = 5V C _L = 300pF R _L = 500Ω			T _{amb} = 0 °C to +70°C V _{CC} = 5V ±10% C _L = 300pF R _L = 500Ω		
				MIN	Typ	Max	MIN	Max	
t _{PLH} t _{PHL}	Propagation delay D _n to Q _n	74F827	Waveform 1		9.5 7.5	13.0 10.0		14.0 11.0	ns
t _{PZH} t _{PZL}			Output enable time OE _n to Q _n	Waveform 3 Waveform 4		15.0 9.5	20.0 13.0		
t _{PHZ} t _{PLZ}	Output disable time OE _n to Q _n		Waveform 3 Waveform 4		15.0 9.5	19.0 13.5		20.0 14.0	ns
t _{PLH} t _{PHL}	Propagation delay D _n to Q _n	74F828	Waveform 2		10.0 6.0	13.0 9.0		14.0 10.0	
t _{PZH} t _{PZL}			Output enable time OE _n to Q _n	Waveform 3 Waveform 4		15.5 10.5	19.0 13.0		21.0 14.0
t _{PHZ} t _{PLZ}	Output disable time OE _n to Q _n		Waveform 3 Waveform 4		15.0 10.0	18.0 13.0		20.0 14.5	ns

Buffers

74F827, 74F828

AC CHARACTERISTICS

for 10 Outputs switching with $C_L = 300\text{pF}$ and $R_L = 500\Omega$ load

SYMBOL	PARAMETER		LIMITS	LIMITS					UNIT
				$T_{amb} = +25^\circ\text{C}$ $V_{CC} = 5\text{V}$ $C_L = 50\text{pF}$ $R_L = 500\Omega$			$T_{amb} = 0^\circ\text{C to } +70^\circ\text{C}$ $V_{CC} = 5\text{V} \pm 10\%$ $C_L = 50\text{pF}$ $R_L = 500\Omega$		
				MIN	Typ	Max	MIN	Max	
t_{PLH} t_{PHL}	Propagation delay D_n to Q_n	74F827	Waveform 1		12.0 14.0	16.0 17.0		17.0 18.0	ns
t_{PZH} t_{PZL}	Output enable time \overline{OE}_n to Q_n		Waveform 3 Waveform 4		15.0 17.0	20.0 21.0		21.0 21.5	ns
t_{PHZ} t_{PLZ}	Output disable time \overline{OE}_n to Q_n		Waveform 3 Waveform 4		15.0 12.5	19.0 15.5		20.0 16.0	ns
t_{PLH} t_{PHL}	Propagation delay D_n to \overline{Q}_n	74F828	Waveform 2		10.0 10.0	17.0 13.5		18.0 14.0	ns
t_{PZH} t_{PZL}	Output enable time \overline{OE}_n to \overline{Q}_n		Waveform 3 Waveform 4		18.0 15.0	21.0 18.0		23.0 19.0	ns
t_{PHZ} t_{PLZ}	Output disable time \overline{OE}_n to \overline{Q}_n		Waveform 3 Waveform 4		16.5 11.5	19.5 14.5		22.5 15.0	ns

AC WAVEFORMS

For all waveforms, $V_M = 1.5\text{V}$

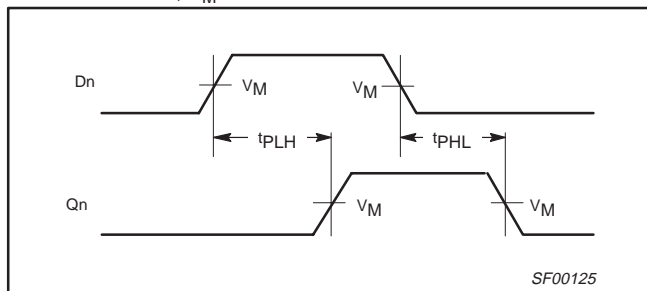

Waveform 1. Propagation Delay for Non-Inverting Output

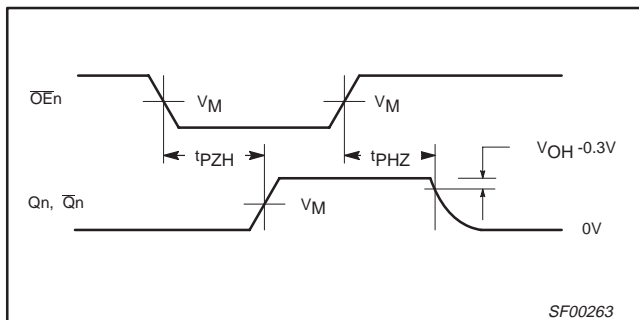

Waveform 3. 3-State Output Enable Time to High Level and Output Disable Time from High Level

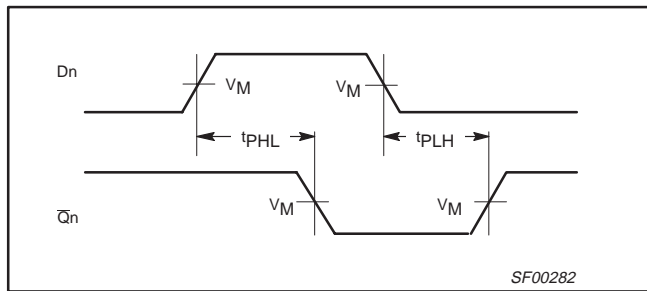

Waveform 2. Propagation Delay for Inverting Output

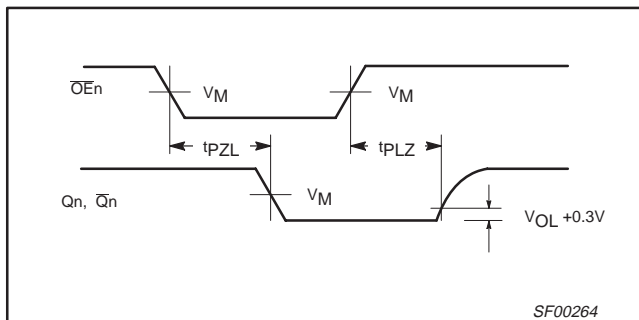

Waveform 4. 3-State Output Enable Time to Low Level and Output Disable Time from Low Level

Buffers

74F827, 74F828

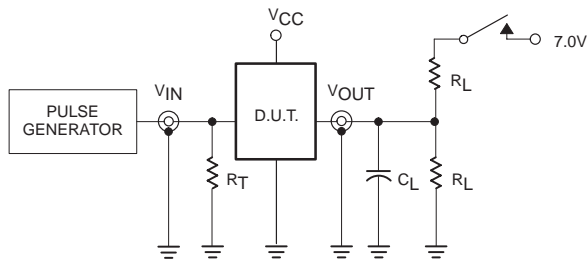

Test Circuit for Open Collector Outputs

SWITCH POSITION

TEST	SWITCH
t_{PLZ}	closed
t_{PZL}	closed
All other	open

DEFINITIONS:

- R_L = Load resistor; see AC electrical characteristics for value.
- C_L = Load capacitance includes jig and probe capacitance; see AC electrical characteristics for value.
- R_T = Termination resistance should be equal to Z_{OUT} of pulse generators.

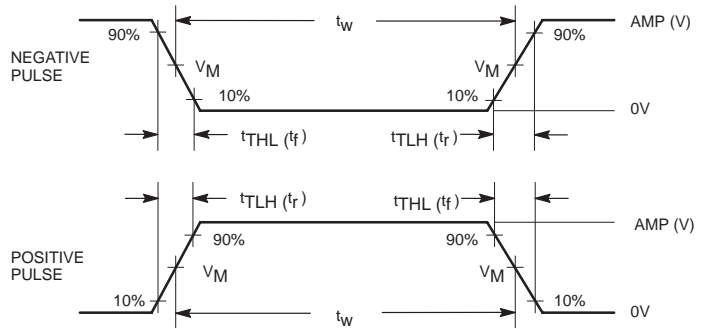

Input Pulse Definition

family	INPUT PULSE REQUIREMENTS					
	amplitude	V_M	rep. rate	t_w	t_{TLH}	t_{THL}
74F	3.0V	1.5V	1MHz	500ns	2.5ns	2.5ns

SF00128

Buffers

74F827, 74F828

DIP24: plastic dual in-line package; 24 leads (300 mil)

SOT222-1

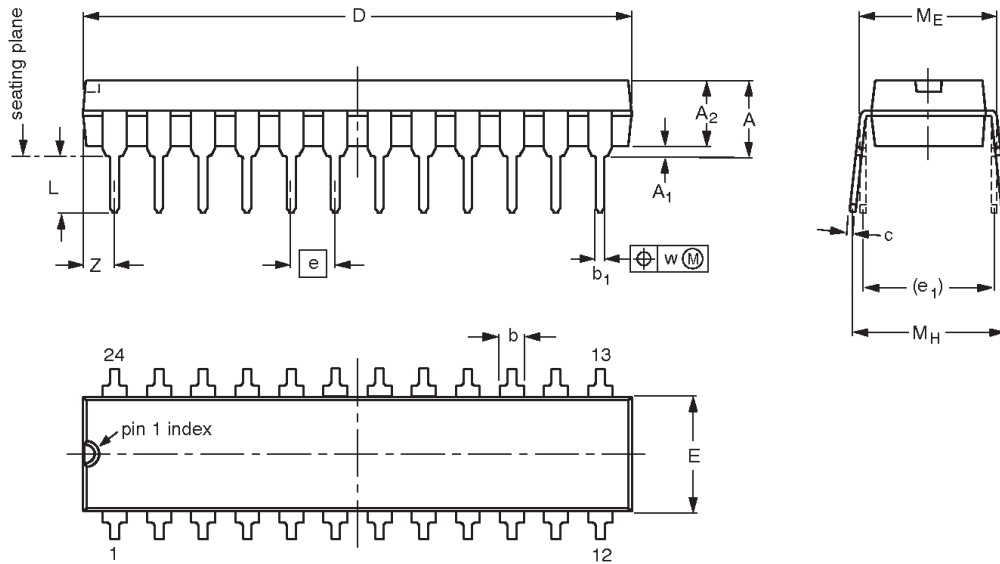

DIMENSIONS (millimetre dimensions are derived from the original inch dimensions)

UNIT	A max.	A ₁ min.	A ₂ max.	b	b ₁	c	D ⁽¹⁾	E ⁽¹⁾	e	e ₁	L	M _E	M _H	w	Z ⁽¹⁾ max.
mm	4.70	0.38	3.94	1.63 1.14	0.56 0.43	0.36 0.25	31.9 31.5	6.73 6.48	2.54	7.62	3.51 3.05	8.13 7.62	10.03 7.62	0.25	2.05
inches	0.185	0.015	0.155	0.064 0.045	0.022 0.017	0.014 0.010	1.256 1.240	0.265 0.255	0.100	0.300	0.138 0.120	0.32 0.30	0.395 0.300	0.01	0.081

Note

1. Plastic or metal protrusions of 0.01 inches maximum per side are not included.

OUTLINE VERSION	REFERENCES				EUROPEAN PROJECTION	ISSUE DATE
	IEC	JEDEC	EIAJ			
SOT222-1		MS-001AF				95-03-11

Buffers

74F827, 74F828

SO24: plastic small outline package; 24 leads; body width 7.5 mm

SOT137-1

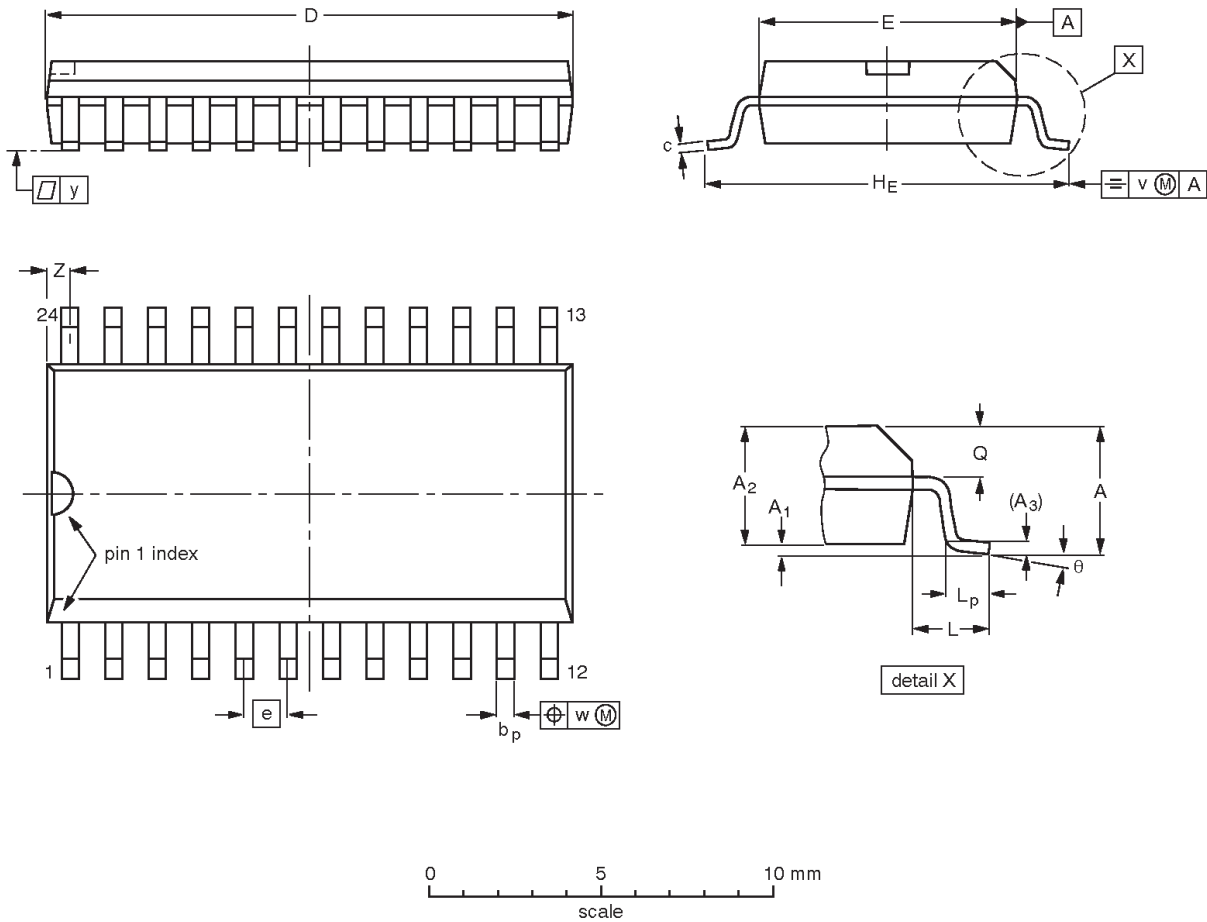

DIMENSIONS (inch dimensions are derived from the original mm dimensions)

UNIT	A max.	A ₁	A ₂	A ₃	b _p	c	D ⁽¹⁾	E ⁽¹⁾	e	H _E	L	L _p	Q	v	w	y	z ⁽¹⁾	θ
mm	2.65	0.30 0.10	2.45 2.25	0.25	0.49 0.36	0.32 0.23	15.6 15.2	7.6 7.4	1.27	10.65 10.00	1.4	1.1 0.4	1.1 1.0	0.25	0.25	0.1	0.9 0.4	8° 0°
inches	0.10	0.012 0.004	0.096 0.089	0.01	0.019 0.014	0.013 0.009	0.61 0.60	0.30 0.29	0.050	0.419 0.394	0.055	0.043 0.016	0.043 0.039	0.01	0.01	0.004	0.035 0.016	

Note

1. Plastic or metal protrusions of 0.15 mm maximum per side are not included.

OUTLINE VERSION	REFERENCES				EUROPEAN PROJECTION	ISSUE DATE
	IEC	JEDEC	EIAJ			
SOT137-1	075E05	MS-013AD				95-01-24 97-05-22

Buffers

74F827, 74F828

SSOP24: plastic shrink small outline package; 24 leads; body width 5.3 mm

SOT340-1

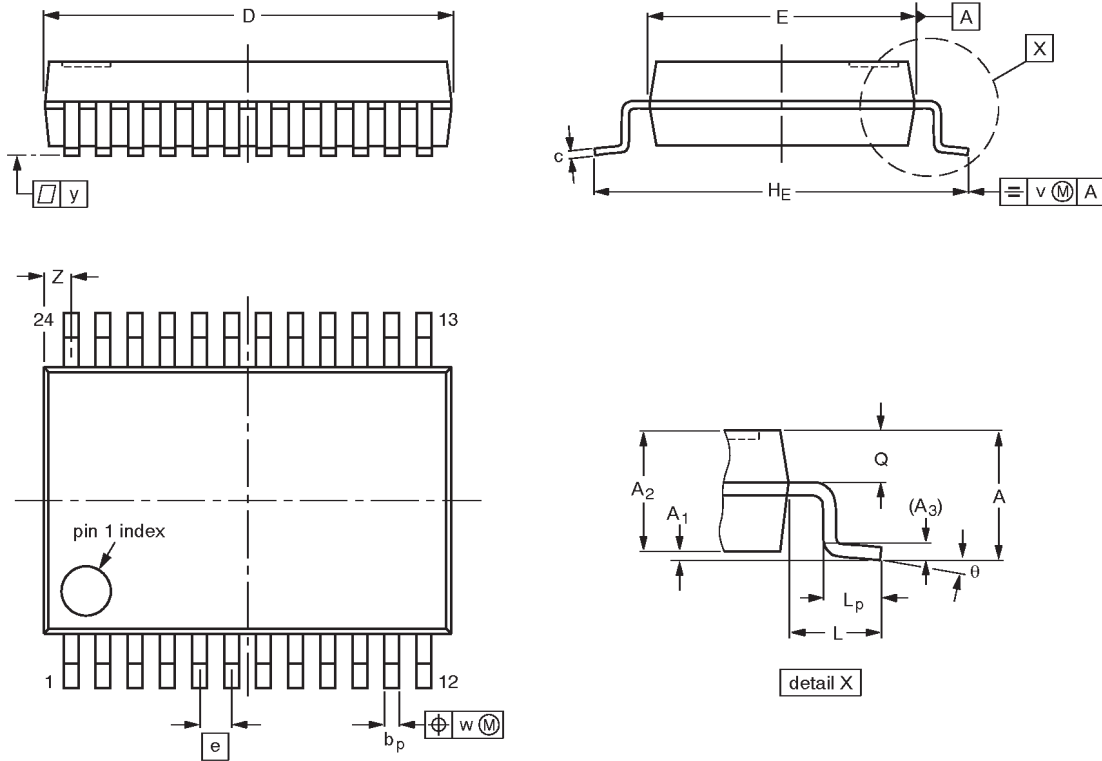

DIMENSIONS (mm are the original dimensions)

UNIT	A max.	A ₁	A ₂	A ₃	b _p	c	D ⁽¹⁾	E ⁽¹⁾	e	H _E	L	L _p	Q	v	w	y	Z ⁽¹⁾	θ
mm	2.0	0.21 0.05	1.80 1.65	0.25	0.38 0.25	0.20 0.09	8.4 8.0	5.4 5.2	0.65	7.9 7.6	1.25	1.03 0.63	0.9 0.7	0.2	0.13	0.1	0.8 0.4	8° 0°

Note

1. Plastic or metal protrusions of 0.20 mm maximum per side are not included.

OUTLINE VERSION	REFERENCES				EUROPEAN PROJECTION	ISSUE DATE
	IEC	JEDEC	EIAJ			
SOT340-1		MO-150AG				93-09-08 95-02-04

Buffers

74F827, 74F828

DEFINITIONS

Data Sheet Identification	Product Status	Definition
<i>Objective Specification</i>	Formative or in Design	This data sheet contains the design target or goal specifications for product development. Specifications may change in any manner without notice.
<i>Preliminary Specification</i>	Preproduction Product	This data sheet contains preliminary data, and supplementary data will be published at a later date. Philips Semiconductors reserves the right to make changes at any time without notice in order to improve design and supply the best possible product.
<i>Product Specification</i>	Full Production	This data sheet contains Final Specifications. Philips Semiconductors reserves the right to make changes at any time without notice, in order to improve design and supply the best possible product.

Philips Semiconductors and Philips Electronics North America Corporation reserve the right to make changes, without notice, in the products, including circuits, standard cells, and/or software, described or contained herein in order to improve design and/or performance. Philips Semiconductors assumes no responsibility or liability for the use of any of these products, conveys no license or title under any patent, copyright, or mask work right to these products, and makes no representations or warranties that these products are free from patent, copyright, or mask work right infringement, unless otherwise specified. Applications that are described herein for any of these products are for illustrative purposes only. Philips Semiconductors makes no representation or warranty that such applications will be suitable for the specified use without further testing or modification.

LIFE SUPPORT APPLICATIONS

Philips Semiconductors and Philips Electronics North America Corporation Products are not designed for use in life support appliances, devices, or systems where malfunction of a Philips Semiconductors and Philips Electronics North America Corporation Product can reasonably be expected to result in a personal injury. Philips Semiconductors and Philips Electronics North America Corporation customers using or selling Philips Semiconductors and Philips Electronics North America Corporation Products for use in such applications do so at their own risk and agree to fully indemnify Philips Semiconductors and Philips Electronics North America Corporation for any damages resulting from such improper use or sale.

Philips Semiconductors
811 East Arques Avenue
P.O. Box 3409
Sunnyvale, California 94088-3409
Telephone 800-234-7381

Philips Semiconductors and Philips Electronics North America Corporation register eligible circuits under the Semiconductor Chip Protection Act.
 © Copyright Philips Electronics North America Corporation 1994
 All rights reserved. Printed in U.S.A.