

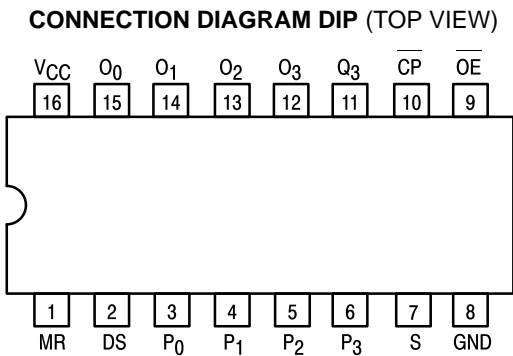

4-BIT SHIFT REGISTER WITH 3-STATE OUTPUTS

The SN74LS395 is a 4-Bit Register with 3-state outputs and can operate in either a synchronous parallel load or a serial shift-right mode, as determined by the Select input. An asynchronous active LOW Master Reset (MR) input overrides the synchronous operations and clears the register. An active HIGH Output Enable (OE) input controls the 3-state output buffers, but does not interfere with the other operations. The fourth stage also has a conventional output for linking purposes in multi-stage serial operations.

- Shift Left or Parallel 4-Bit Register
- 3-State Outputs
- Input Clamp Diodes Limit High-Speed Termination Effects



PIN NAMES

P ₀ –P ₃	Parallel Inputs
D _S	Serial Data Input
S	Mode Select Input
CP	Clock (Active LOW) Input
MR	Master Reset (Active LOW) Input
OE	Output Enable (Active HIGH) Input
O ₀ –O ₃	3-State Register Outputs
Q ₃	Register Output

NOTES:

a) 1 TTL Unit Load (U.L.) = 40 μA HIGH/1.6 mA LOW.

LOADING (Note a)

	HIGH	LOW
O ₀ –O ₃	0.5 U.L.	0.25 U.L.
Q ₃	0.5 U.L.	0.25 U.L.
P ₀ –P ₃	0.5 U.L.	0.25 U.L.
CP	0.5 U.L.	0.25 U.L.
MR	0.5 U.L.	0.25 U.L.
OE	0.5 U.L.	0.25 U.L.
O ₀ –O ₃	65 U.L.	15 U.L.
Q ₃	10 U.L.	5 U.L.

SN74LS395

4-BIT SHIFT REGISTER WITH 3-STATE OUTPUTS LOW POWER SCHOTTKY

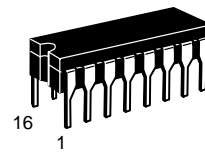

J SUFFIX
CERAMIC
CASE 620-09

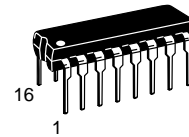

N SUFFIX
PLASTIC
CASE 648-08

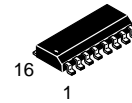

D SUFFIX
SOIC
CASE 751B-03

ORDERING INFORMATION

SN74LSXXXJ	Ceramic
SN74LSXXXN	Plastic
SN74LSXXXD	SOIC

LOGIC SYMBOL

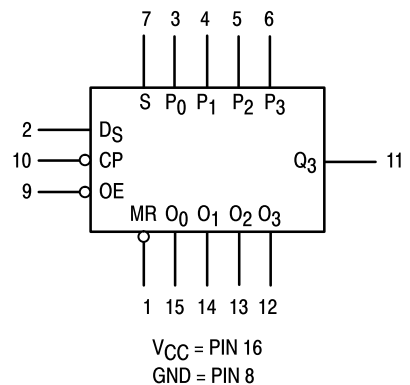

SN74LS395

LOGIC DIAGRAM

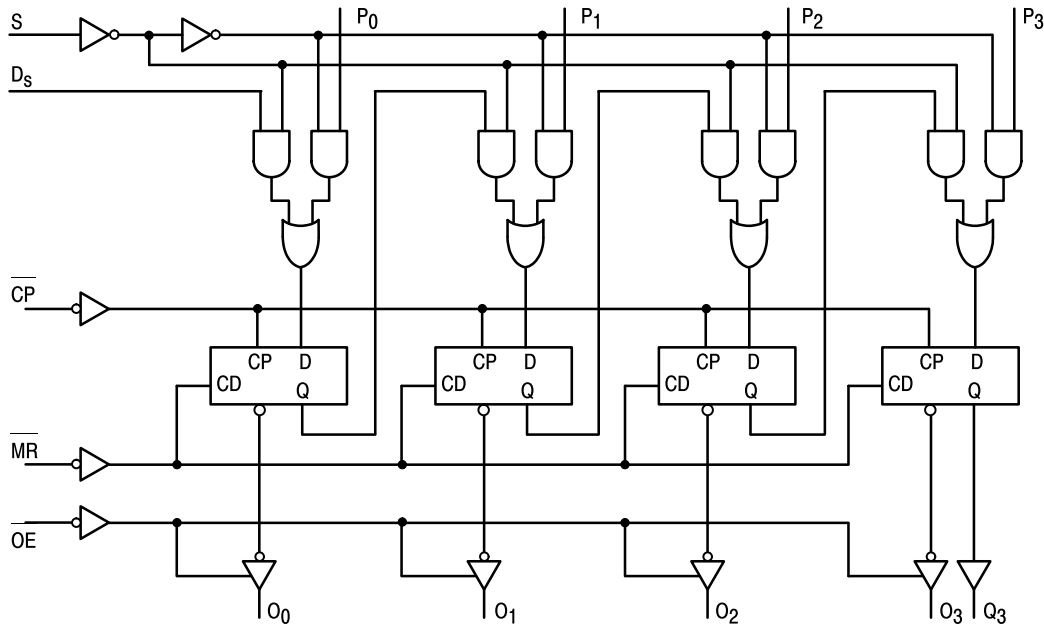

FUNCTION DESCRIPTION

The SN74LS395 contains four D-type edge-triggered flip-flops and auxiliary gating to select a D input either from a Parallel (P_n) input or from the preceding stage. When the Select input is HIGH, the P_n inputs are enabled. A LOW signal on the S input enables the serial inputs for shift-right operations, as indicated in the Truth Table.

State changes are initiated by HIGH-to-LOW transitions on the Clock Pulse (CP) input. Signals on the P_n , D_s and S inputs can change when the Clock is in either state, provided that the recommended set-up and hold times are observed. When the

S input is LOW, a CP HIGH-LOW transition transfers data in Q_0 to Q_1 , Q_1 to Q_2 , and Q_2 to Q_3 . A left-shift is accomplished by connecting the outputs back to the P_n inputs, but offset one place to the left, i.e., O_3 to P_2 , O_2 to P_1 and O_1 to P_0 , with P_3 acting as the linking input from another package.

When the OE input is HIGH, the output buffers are disabled and the Q_0 – Q_3 outputs are in a high impedance condition. The shifting, parallel loading or resetting operations can still be accomplished, however.

MODE SELECT — TRUTH TABLE

Operating Mode	Inputs @ t_n					Outputs @ t_{n+1}			
	MR	CP	S	D_s	P_n	O_0	O_1	O_2	O_3
Asynchronous Reset	L	X	X	X	X	L	L	L	L
Shift, SET First Stage	H		L	H	X	H	O_{0n}	O_{1n}	O_{2n}
Shift, RESET First Stage	H		L	L	X	L	O_{0n}	O_{1n}	O_{2n}
Parallel Load	H		H	X	P_n	P_0	P_1	P_2	P_3

H = HIGH Voltage Level

L = LOW Voltage Level

X = Immaterial

t_n, t_{n+1} = time before and after CP HIGH-to-LOW transition

NOTE:___

When OE is HIGH, outputs O_0 – O_3 are in the high impedance state; however, this does not affect other operations or the Q_3 output.

GUARANTEED OPERATING RANGES

Symbol	Parameter	Min	Typ	Max	Unit
V_{CC}	Supply Voltage	4.75	5.0	5.25	V
T_A	Operating Ambient Temperature Range	0	25	70	°C
I_{OH}	Output Current — High			–0.4	mA
I_{OL}	Output Current — Low			8.0	mA

SN74LS395

DC CHARACTERISTICS OVER OPERATING TEMPERATURE RANGE (unless otherwise specified)

Symbol	Parameter	Limits			Unit	Test Conditions
		Min	Typ	Max		
V _{IH}	Input HIGH Voltage	2.0			V	Guaranteed Input HIGH Voltage for All Inputs
V _{IL}	Input LOW Voltage			0.8	V	Guaranteed Input LOW Voltage for All Inputs
V _{IK}	Input Clamp Diode Voltage		-0.65	-1.5	V	V _{CC} = MIN, I _{IN} = -18 mA
V _{OH}	Output HIGH Voltage	2.7	3.5		V	V _{CC} = MIN, I _{OH} = MAX, V _{IN} = V _{IH} or V _{IL} per Truth Table
V _{OL}	Output LOW Voltage		0.25	0.4	V	I _{OL} = 4.0 mA V _{CC} = V _{CC} MIN, V _{IN} = V _{IL} or V _{IH} per Truth Table
			0.35	0.5	V	
I _{OZH}	Output Off Current HIGH			20	μA	V _{CC} = MAX, V _O = 2.4 V
I _{OZL}	Output Off Current LOW			-20	μA	V _{CC} = MAX, V _O = 0.4 V
I _{IH}	Input HIGH Current			20	μA	V _{CC} = MAX, V _{IN} = 2.7 V
				-0.1	mA	V _{CC} = MAX, V _{IN} = 7.0 V
I _{IL}	Input LOW Current			-0.4	mA	V _{CC} = MAX, V _{IN} = 0.4 V
I _{OS}	Short Circuit Current (Note 1)	-20		-100	mA	V _{CC} = MAX
I _{CC}	Power Supply Current Total, Output HIGH			31	mA	V _{CC} = MAX, OE = GND, CP = GND
	Total, Output LOW			34	mA	V _{CC} = MAX, OE = 4.5 V, CP momentary 3.0 V then GND

Note 1: Not more than one output should be shorted at a time, nor for more than 1 second.

AC CHARACTERISTICS (T_A = 25°C)

Symbol	Parameter	Limits			Unit	Test Conditions
		Min	Typ	Max		
f _{MAX}	Maximum Input Clock Frequency	30	45		MHz	V _{CC} = 5.0 V C _L = 15 pF
t _{PHL}	Propagation Delay, Clear to Output		22	35	ns	
t _{PLH} t _{PHL}	Propagation Delay, Low to High Propagation Delay, High to Low		15 25	30 30	ns	
t _{PZH} t _{PZL}	Output Enable Time		15 17	25 25	ns	
t _{PLZ} t _{PHZ}	Output Disable Time		12 11	20 17	ns	C _L = 5.0 pF

AC SETUP REQUIREMENTS (T_A = 25°C)

Symbol	Parameter	Limits			Unit	Test Conditions
		Min	Typ	Max		
t _W	Clock Pulse Width	16			ns	V _{CC} = 5.0 V
t _s	Setup Time, Mode Select	40			ns	
t _s	Setup Time, All Others	20			ns	
t _h	Data Hold Time	10			ns	

SN74LS395

AC WAVEFORMS

The shaded areas indicate when the input is permitted to change for predictable output performance.

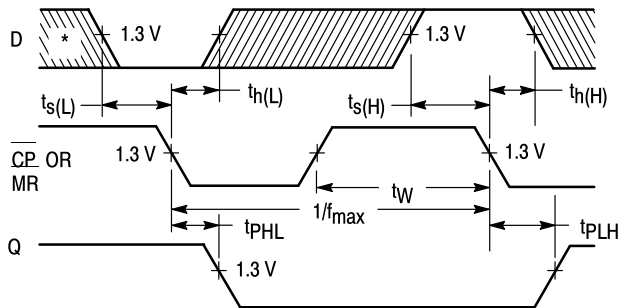

*The Data Input is D_S for $S = \text{LOW}$ and P_n for $S = \text{HIGH}$.

Figure 1

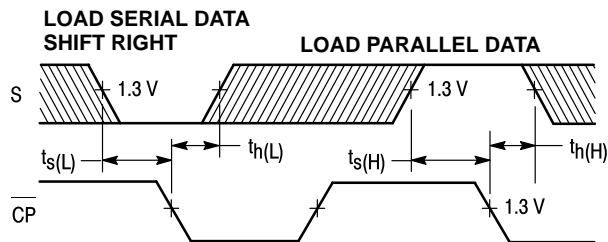

Figure 2

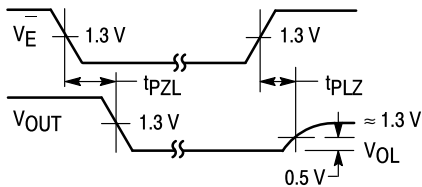

Figure 3

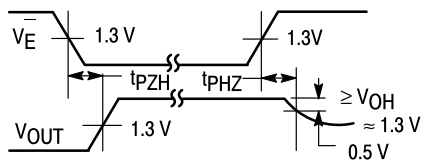
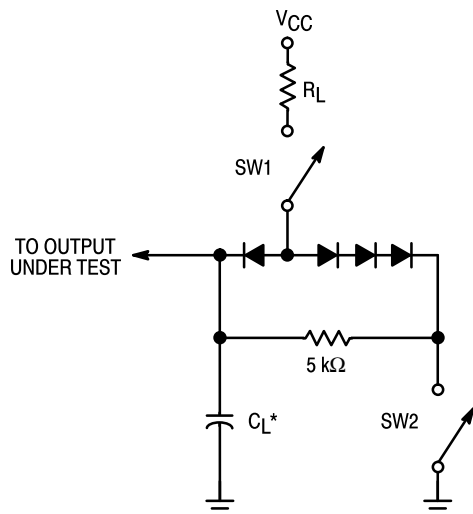

Figure 4

AC LOAD CIRCUIT



* Includes Jig and Probe Capacitance.

Figure 5

SWITCH POSITIONS

SYMBOL	SW1	SW2
t_{pZH}	Open	Closed
t_{pZL}	Closed	Open
t_{pLZ}	Closed	Closed
t_{pHZ}	Closed	Closed

**Case 751B-03 D Suffix
16-Pin Plastic
SO-16**



- NOTES:
1. DIMENSIONING AND TOLERANCING PER ANSI Y14.5M, 1982.
 2. CONTROLLING DIMENSION: MILLIMETER.
 3. DIMENSION A AND B DO NOT INCLUDE MOLD PROTRUSION.
 4. MAXIMUM MOLD PROTRUSION 0.15 (0.006) PER SIDE.
 5. 751B-01 IS OBSOLETE, NEW STANDARD 751B-03.

DIM	MILLIMETERS		INCHES	
	MIN	MAX	MIN	MAX
A	9.80	10.00	0.386	0.393
B	3.80	4.00	0.150	0.157
C	1.35	1.75	0.054	0.068
D	0.35	0.49	0.014	0.019
F	0.40	1.25	0.016	0.049
G	1.27 BSC		0.050 BSC	
J	0.19	0.25	0.008	0.009
K	0.10	0.25	0.004	0.009
M	0°	7°	0°	7°
P	5.80	6.20	0.229	0.244
R	0.25	0.50	0.010	0.019

**Case 648-08 N Suffix
16-Pin Plastic**



- NOTES:
1. DIMENSIONING AND TOLERANCING PER ANSI Y14.5M, 1982.
 2. CONTROLLING DIMENSION: INCH.
 3. DIMENSION "L" TO CENTER OF LEADS WHEN FORMED PARALLEL.
 4. DIMENSION "B" DOES NOT INCLUDE MOLD FLASH.
 5. ROUNDED CORNERS OPTIONAL.
 6. 648-01 THRU -07 OBSOLETE, NEW STANDARD 648-08.

DIM	MILLIMETERS		INCHES	
	MIN	MAX	MIN	MAX
A	18.80	19.55	0.740	0.770
B	6.35	6.85	0.250	0.270
C	3.69	4.44	0.145	0.175
D	0.39	0.53	0.015	0.021
F	1.02	1.77	0.040	0.070
G	2.54 BSC		0.100 BSC	
H	1.27 BSC		0.050 BSC	
J	0.21	0.38	0.008	0.015
K	2.80	3.30	0.110	0.130
L	7.50	7.74	0.295	0.305
M	0°	10°	0°	10°
S	0.51	1.01	0.020	0.040

**Case 620-09 J Suffix
16-Pin Ceramic Dual In-Line**



- NOTES:
1. DIMENSIONING AND TOLERANCING PER ANSI Y14.5M, 1982.
 2. CONTROLLING DIMENSION: INCH.
 3. DIMENSION L TO CENTER OF LEAD WHEN FORMED PARALLEL.
 4. DIM F MAY NARROW TO 0.76 (0.030) WHERE THE LEAD ENTERS THE CERAMIC BODY.
 5. 620-01 THRU -08 OBSOLETE, NEW STANDARD 620-09.

DIM	MILLIMETERS		INCHES	
	MIN	MAX	MIN	MAX
A	19.05	19.55	0.750	0.770
B	6.10	7.36	0.240	0.290
C	—	4.19	—	0.165
D	0.39	0.53	0.015	0.021
E	1.27 BSC		0.050 BSC	
F	1.40	1.77	0.055	0.070
G	2.54 BSC		0.100 BSC	
J	0.23	0.27	0.009	0.011
K	—	5.08	—	0.200
L	7.62 BSC		0.300 BSC	
M	0°	15°	0°	15°
N	0.39	0.88	0.015	0.035

Motorola reserves the right to make changes without further notice to any products herein. Motorola makes no warranty, representation or guarantee regarding the suitability of its products for any particular purpose, nor does Motorola assume any liability arising out of the application or use of any product or circuit, and specifically disclaims any and all liability, including without limitation consequential or incidental damages. "Typical" parameters can and do vary in different applications. All operating parameters, including "Typicals" must be validated for each customer application by customer's technical experts. Motorola does not convey any license under its patent rights nor the rights of others. Motorola products are not designed, intended, or authorized for use as components in systems intended for surgical implant into the body, or other applications intended to support or sustain life, or for any other application in which the failure of the Motorola product could create a situation where personal injury or death may occur. Should Buyer purchase or use Motorola products for any such unintended or unauthorized application, Buyer shall indemnify and hold Motorola and its officers, employees, subsidiaries, affiliates, and distributors harmless against all claims, costs, damages, and expenses, and reasonable attorney fees arising out of, directly or indirectly, any claim of personal injury or death associated with such unintended or unauthorized use, even if such claim alleges that Motorola was negligent regarding the design or manufacture of the part. Motorola and  are registered trademarks of Motorola, Inc. Motorola, Inc. is an Equal Opportunity/Affirmative Action Employer.

Literature Distribution Centers:

USA: Motorola Literature Distribution; P.O. Box 20912; Phoenix, Arizona 85036.

EUROPE: Motorola Ltd.; European Literature Centre; 88 Tanners Drive, Blakelands, Milton Keynes, MK14 5BP, England.

JAPAN: Nippon Motorola Ltd.; 4-32-1, Nishi-Gotanda, Shinagawa-ku, Tokyo 141, Japan.

ASIA PACIFIC: Motorola Semiconductors H.K. Ltd.; Silicon Harbour Center, No. 2 Dai King Street, Tai Po Industrial Estate, Tai Po, N.T., Hong Kong.

