



## LOW VOLTAGE CMOS QUAD 2-INPUT NAND GATE

- HIGH SPEED:  
 $t_{PD} = 5.5\text{ns}$  (TYP.) at  $V_{CC} = 3.3\text{V}$
- COMPATIBLE WITH TTL OUTPUTS
- LOW POWER DISSIPATION:  
 $I_{CC} = 2\mu\text{A}$  (MAX.) at  $T_A = 25^\circ\text{C}$
- LOW NOISE:  
 $V_{OLP} = 0.3\text{V}$  (TYP.) at  $V_{CC} = 3.3\text{V}$
- 75Ω TRANSMISSION LINE DRIVING CAPABILITY
- SYMMETRICAL OUTPUT IMPEDANCE:  
 $|I_{OH}| = I_{OL} = 12\text{mA}$  (MIN) at  $V_{CC} = 3.0\text{V}$
- PCI BUS LEVELS GUARANTEED AT 24 mA
- BALANCED PROPAGATION DELAYS:  
 $t_{PLH} \approx t_{PHL}$
- OPERATING VOLTAGE RANGE:  
 $V_{CC}(\text{OPR}) = 2\text{V}$  to  $3.6\text{V}$  (1.2V Data Retention)
- PIN AND FUNCTION COMPATIBLE WITH 74 SERIES 00
- IMPROVED LATCH-UP IMMUNITY

### DESCRIPTION

The 74LVQ00 is a low voltage CMOS QUAD 2-INPUT NAND GATE fabricated with sub-micron silicon gate and double-layer metal wiring C<sup>2</sup>MOS

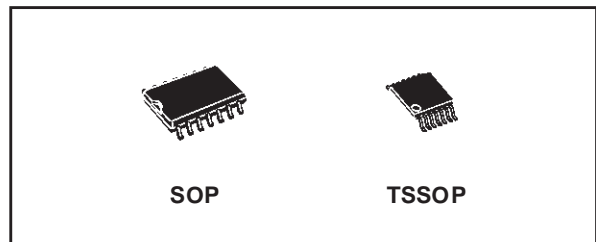

### ORDER CODES

| PACKAGE | TUBE     | T & R      |
|---------|----------|------------|
| SOP     | 74LVQ00M | 74LVQ00MTR |
| TSSOP   |          | 74LVQ00TTR |

technology. It is ideal for low power and low noise 3.3V applications.

The internal circuit is composed of 3 stages including buffer output, which enables high noise immunity and stable output.

All inputs and outputs are equipped with protection circuits against static discharge, giving them 2KV ESD immunity and transient excess voltage.

### PIN CONNECTION AND IEC LOGIC SYMBOLS

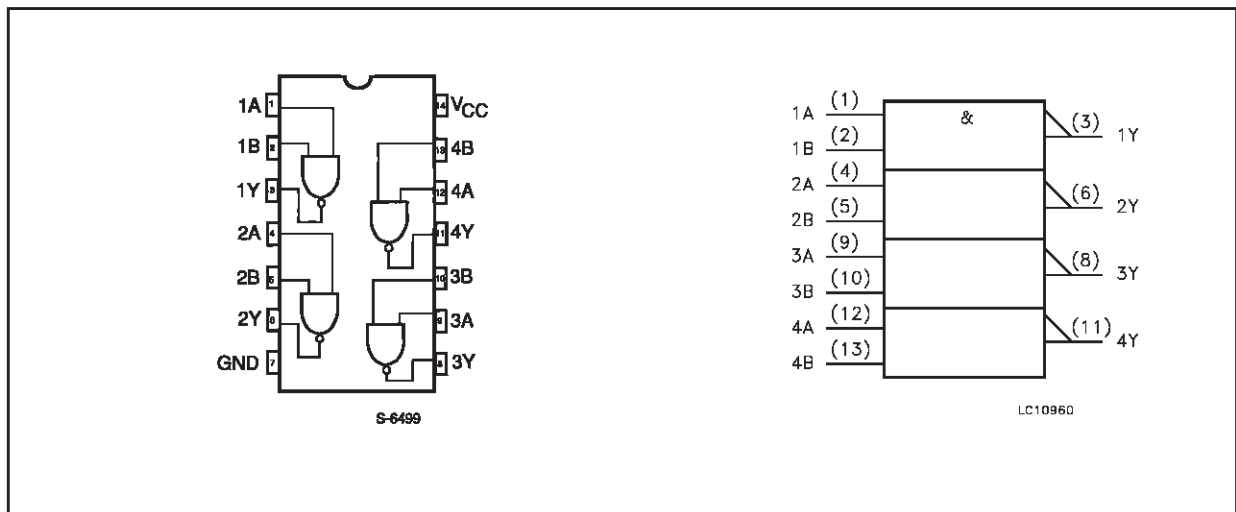

INPUT AND OUTPUT EQUIVALENT CIRCUIT

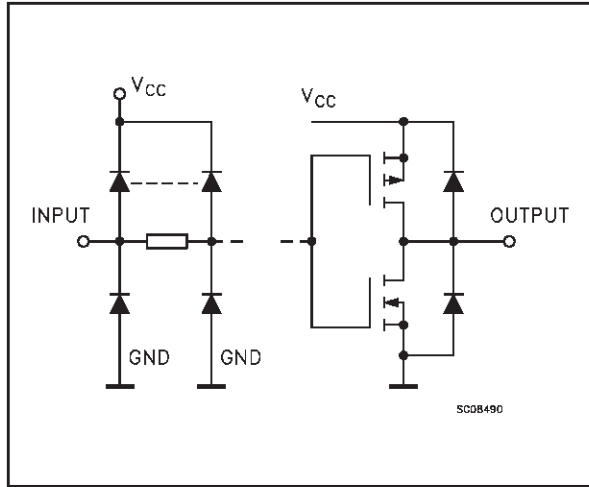

PIN DESCRIPTION

| PIN No       | SYMBOL          | NAME AND FUNCTION       |
|--------------|-----------------|-------------------------|
| 1, 4, 9, 12  | 1A to 4A        | Data Inputs             |
| 2, 5, 10, 13 | 1B to 4B        | Data Inputs             |
| 3, 6, 8, 11  | 1Y to 4Y        | Data Outputs            |
| 7            | GND             | Ground (0V)             |
| 14           | V <sub>CC</sub> | Positive Supply Voltage |

TRUTH TABLE

| A | B | Y |
|---|---|---|
| L | L | H |
| L | H | H |
| H | L | H |
| H | H | L |

ABSOLUTE MAXIMUM RATINGS

| Symbol                              | Parameter                            | Value                         | Unit |
|-------------------------------------|--------------------------------------|-------------------------------|------|
| V <sub>CC</sub>                     | Supply Voltage                       | -0.5 to +7                    | V    |
| V <sub>I</sub>                      | DC Input Voltage                     | -0.5 to V <sub>CC</sub> + 0.5 | V    |
| V <sub>O</sub>                      | DC Output Voltage                    | -0.5 to V <sub>CC</sub> + 0.5 | V    |
| I <sub>IK</sub>                     | DC Input Diode Current               | ± 20                          | mA   |
| I <sub>OK</sub>                     | DC Output Diode Current              | ± 20                          | mA   |
| I <sub>O</sub>                      | DC Output Current                    | ± 50                          | mA   |
| I <sub>CC</sub> or I <sub>GND</sub> | DC V <sub>CC</sub> or Ground Current | ± 200                         | mA   |
| T <sub>stg</sub>                    | Storage Temperature                  | -65 to +150                   | °C   |
| T <sub>L</sub>                      | Lead Temperature (10 sec)            | 300                           | °C   |

Absolute Maximum Ratings are those values beyond which damage to the device may occur. Functional operation under these conditions is not implied

RECOMMENDED OPERATING CONDITIONS

| Symbol          | Parameter  | Value                | Unit |
|-----------------|--|----------------------|------|
| V <sub>CC</sub> | Supply Voltage (note 1)                                  | 2 to 3.6             | V    |
| V <sub>I</sub>  | Input Voltage  | 0 to V <sub>CC</sub> | V    |
| V <sub>O</sub>  | Output Voltage   | 0 to V <sub>CC</sub> | V    |
| T <sub>op</sub> | Operating Temperature                                    | -55 to 125           | °C   |
| dt/dv           | Input Rise and Fall Time V <sub>CC</sub> = 3.0V (note 2) | 0 to 10              | ns/V |

1) Truth Table guaranteed: 1.2V to 3.6V  
 2) V<sub>IN</sub> from 0.8V to 2V

## DC SPECIFICATIONS

| Symbol           | Parameter                          | Test Condition         |   | Value                 |       |       |             |      |              | Unit |      |
|------------------|------------------------------------|------------------------|---|-----------------------|-------|-------|-------------|------|--------------|------|------|
|                  |                                    | V <sub>CC</sub><br>(V) |   | T <sub>A</sub> = 25°C |       |       | -40 to 85°C |      | -55 to 125°C |      |      |
|                  |                                    |                        |   | Min.                  | Typ.  | Max.  | Min.        | Max. | Min.         |      | Max. |
| V <sub>IH</sub>  | High Level Input Voltage           | 3.0 to 3.6             |   | 2.0                   |       |       | 2.0         |      | 2.0          |      | V    |
| V <sub>IL</sub>  | Low Level Input Voltage            |                        |   |                       | 0.8   |       | 0.8         |      | 0.8          |      | V    |
| V <sub>OH</sub>  | High Level Output Voltage          | 3.0                    | I <sub>O</sub> =-50 μA                  | 2.9                   | 2.99  |       | 2.9         |      | 2.9          |      | V    |
|                  |                                    |                        | I <sub>O</sub> =-12 mA                  | 2.58                  |       |       | 2.48        |      | 2.48         |      |      |
|                  |                                    |                        | I <sub>O</sub> =-24 mA                  |                       |       |       | 2.2         |      | 2.2          |      |      |
| V <sub>OL</sub>  | Low Level Output Voltage           | 3.0                    | I <sub>O</sub> =50 μA                   |                       | 0.002 | 0.1   |             | 0.1  |              | 0.1  | V    |
|                  |                                    |                        | I <sub>O</sub> =12 mA                   |                       | 0     | 0.36  |             | 0.44 |              | 0.44 |      |
|                  |                                    |                        | I <sub>O</sub> =24 mA                   |                       |       |       |             | 0.55 |              | 0.55 |      |
| I <sub>I</sub>   | Input Leakage Current              | 3.6                    | V <sub>I</sub> = V <sub>CC</sub> or GND |                       |       | ± 0.1 |             | ± 1  |              | ± 1  | μA   |
| I <sub>CC</sub>  | Quiescent Supply Current           | 3.6                    | V <sub>I</sub> = V <sub>CC</sub> or GND |                       |       | 2     |             | 20   |              | 20   | μA   |
| I <sub>OLD</sub> | Dynamic Output Current (note 1, 2) | 3.6                    | V <sub>OLD</sub> = 0.8 V max            |                       |       |       | 36          |      | 25           |      | mA   |
| I <sub>OHD</sub> |                                    |                        | V <sub>OHD</sub> = 2 V min              |                       |       |       | -25         |      | -25          |      | mA   |

1) Maximum test duration 2ms, one output loaded at time

2) Incident wave switching is guaranteed on transmission lines with impedances as low as 75Ω

## DYNAMIC SWITCHING CHARACTERISTICS

| Symbol           | Parameter                                    | Test Condition         |                        | Value                 |      |      |             |      |              | Unit |      |
|------------------|--|------------------------|------------------------|-----------------------|------|------|-------------|------|--------------|------|------|
|                  |  | V <sub>CC</sub><br>(V) |                        | T <sub>A</sub> = 25°C |      |      | -40 to 85°C |      | -55 to 125°C |      |      |
|                  |  |                        |                        | Min.                  | Typ. | Max. | Min.        | Max. | Min.         |      | Max. |
| V <sub>OLP</sub> | Dynamic Low Voltage Quiet Output (note 1, 2) | 3.3                    | C <sub>L</sub> = 50 pF |                       | 0.3  | 0.8  |             |      |              |      | V    |
| V <sub>OLV</sub> |  |                        |                        | -0.8                  | -0.3 |      |             |      |              |      |      |
| V <sub>IHD</sub> | Dynamic High Voltage Input (note 1, 3)       | 3.3                    |                        | 2                     |      |      |             |      |              |      | V    |
| V <sub>ILD</sub> | Dynamic Low Voltage Input (note 1, 3)        | 3.3                    |                        |                       |      | 0.8  |             |      |              |      | V    |

1) Worst case package.

2) Max number of outputs defined as (n). Data inputs are driven 0V to 3.3V, (n-1) outputs switching and one output at GND.

3) Max number of data inputs (n) switching. (n-1) switching 0V to 3.3V. Inputs under test switching: 3.3V to threshold (V<sub>ILD</sub>), 0V to threshold (V<sub>IHD</sub>), f=1MHz.

## 74LVQ00

### AC ELECTRICAL CHARACTERISTICS ( $C_L = 50 \text{ pF}$ , $R_L = 500 \Omega$ , Input $t_r = t_f = 3 \text{ ns}$ )

| Symbol                   | Parameter                              | Test Condition  |  | Value                    |      |      |                                    |      |                                     | Unit |      |
|--------------------------|--|-----------------|--|--------------------------|------|------|------------------------------------|------|-------------------------------------|------|------|
|                          |  | $V_{CC}$<br>(V) |  | $T_A = 25^\circ\text{C}$ |      |      | $-40 \text{ to } 85^\circ\text{C}$ |      | $-55 \text{ to } 125^\circ\text{C}$ |      |      |
|                          |  |                 |  | Min.                     | Typ. | Max. | Min.                               | Max. | Min.                                |      | Max. |
| $t_{PLH}$ $t_{PHL}$      | Propagation Delay Time                 | 2.7             |  | .                        | 6.0  | 11.0 |                                    | 12.0 |                                     | 14.0 | ns   |
|                          |  | 3.3(*)          |  |                          | 5.5  | 8.0  |                                    | 9.0  |                                     | 10.0 |      |
| $t_{OSLH}$<br>$t_{OSHL}$ | Output To Output Skew Time (note 1, 2) | 2.7             |  |                          | 0.5  | 1.0  |                                    | 1.0  |                                     | 1.0  | ns   |
|                          |  | 3.3(*)          |  |                          | 0.5  | 1.0  |                                    | 1.0  |                                     | 1.0  |      |

1) Skew is defined as the absolute value of the difference between the actual propagation delay for any two outputs of the same device switching in the same direction, either HIGH or LOW ( $t_{OSLH} = |t_{PLHm} - t_{PLHn}|$ ,  $t_{OSHL} = |t_{PHLm} - t_{PHLn}|$ )

2) Parameter guaranteed by design

(\*) Voltage range is  $3.3\text{V} \pm 0.3\text{V}$

### CAPACITIVE CHARACTERISTICS

| Symbol   | Parameter                              | Test Condition  |                         | Value                    |      |      |                                    |      |                                     | Unit |      |
|----------|--|-----------------|-------------------------|--------------------------|------|------|------------------------------------|------|-------------------------------------|------|------|
|          |  | $V_{CC}$<br>(V) |                         | $T_A = 25^\circ\text{C}$ |      |      | $-40 \text{ to } 85^\circ\text{C}$ |      | $-55 \text{ to } 125^\circ\text{C}$ |      |      |
|          |  |                 |                         | Min.                     | Typ. | Max. | Min.                               | Max. | Min.                                |      | Max. |
| $C_{IN}$ | Input Capacitance                      | 3.3             |                         |                          | 4    |      |                                    |      |                                     |      | pF   |
| $C_{PD}$ | Power Dissipation Capacitance (note 1) | 3.3             | $f_{IN} = 10\text{MHz}$ |                          | 24   |      |                                    |      |                                     |      | pF   |

1)  $C_{PD}$  is defined as the value of the IC's internal equivalent capacitance which is calculated from the operating current consumption without load. (Refer to Test Circuit). Average operating current can be obtained by the following equation.  $I_{CC(opr)} = C_{PD} \times V_{CC} \times f_{IN} + I_{CC}/4$  (per gate)

### TEST CIRCUIT

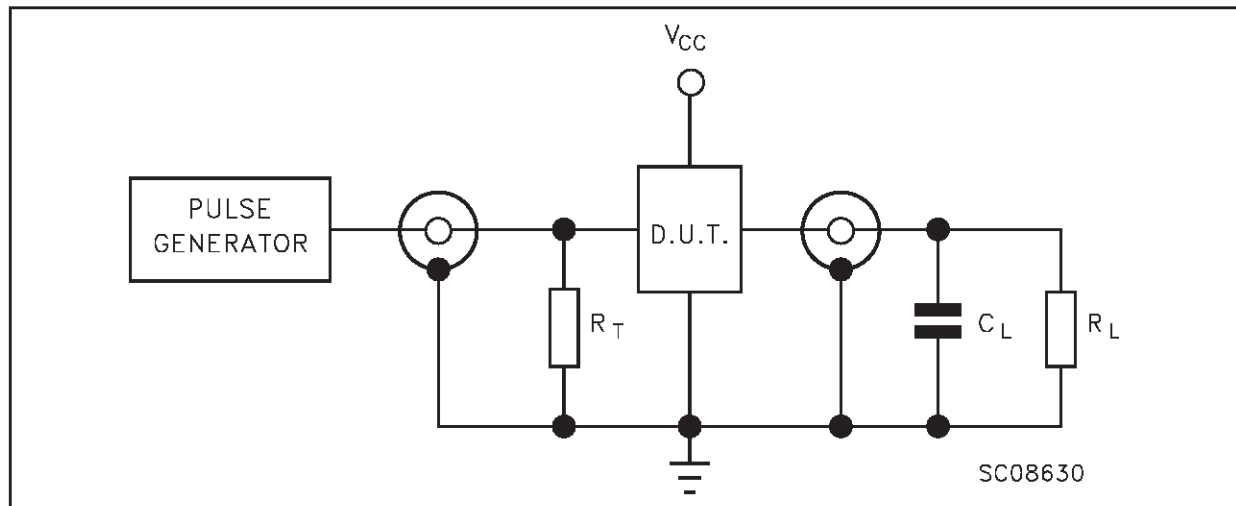

$C_L = 50 \text{ pF}$  or equivalent (includes jig and probe capacitance)

$R_L = 500 \Omega$  or equivalent

$R_T = Z_{OUT}$  of pulse generator (typically  $50 \Omega$ )

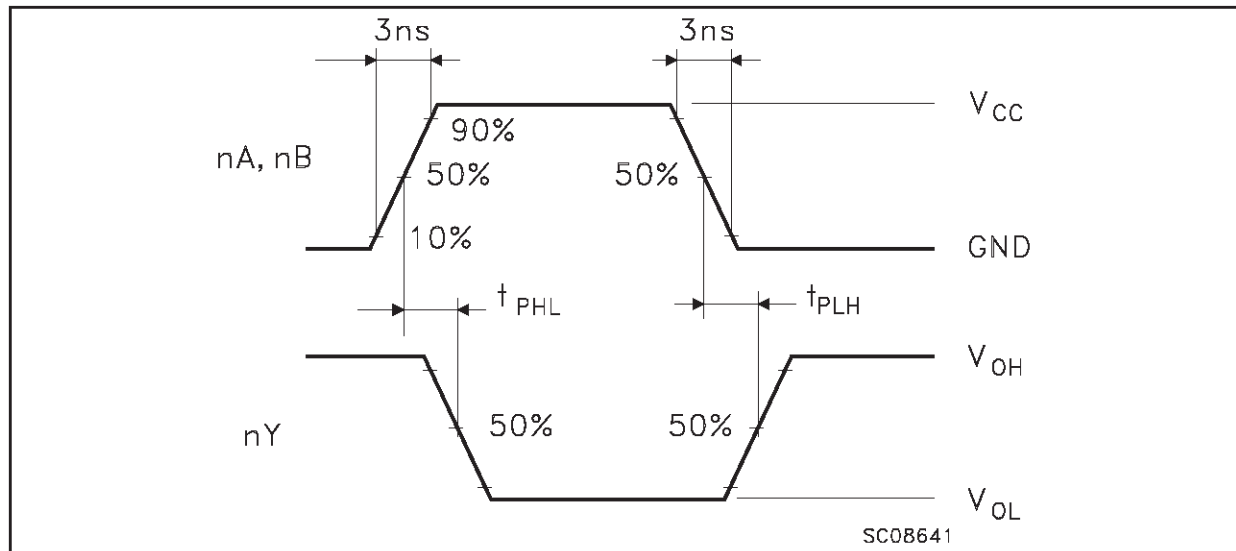
**WAVEFORM: PROPAGATION DELAYS** (f=1MHz; 50% duty cycle)

## SO-14 MECHANICAL DATA

| DIM. | mm.        |      |      | inch  |       |       |
|------|------------|------|------|-------|-------|-------|
|      | MIN.       | TYP. | MAX. | MIN.  | TYP.  | MAX.  |
| A    |            |      | 1.75 |       |       | 0.068 |
| a1   | 0.1        |      | 0.2  | 0.003 |       | 0.007 |
| a2   |            |      | 1.65 |       |       | 0.064 |
| b    | 0.35       |      | 0.46 | 0.013 |       | 0.018 |
| b1   | 0.19       |      | 0.25 | 0.007 |       | 0.010 |
| C    |            | 0.5  |      |       | 0.019 |       |
| c1   | 45° (typ.) |      |      |       |       |       |
| D    | 8.55       |      | 8.75 | 0.336 |       | 0.344 |
| E    | 5.8        |      | 6.2  | 0.228 |       | 0.244 |
| e    |            | 1.27 |      |       | 0.050 |       |
| e3   |            | 7.62 |      |       | 0.300 |       |
| F    | 3.8        |      | 4.0  | 0.149 |       | 0.157 |
| G    | 4.6        |      | 5.3  | 0.181 |       | 0.208 |
| L    | 0.5        |      | 1.27 | 0.019 |       | 0.050 |
| M    |            |      | 0.68 |       |       | 0.026 |
| S    | 8° (max.)  |      |      |       |       |       |

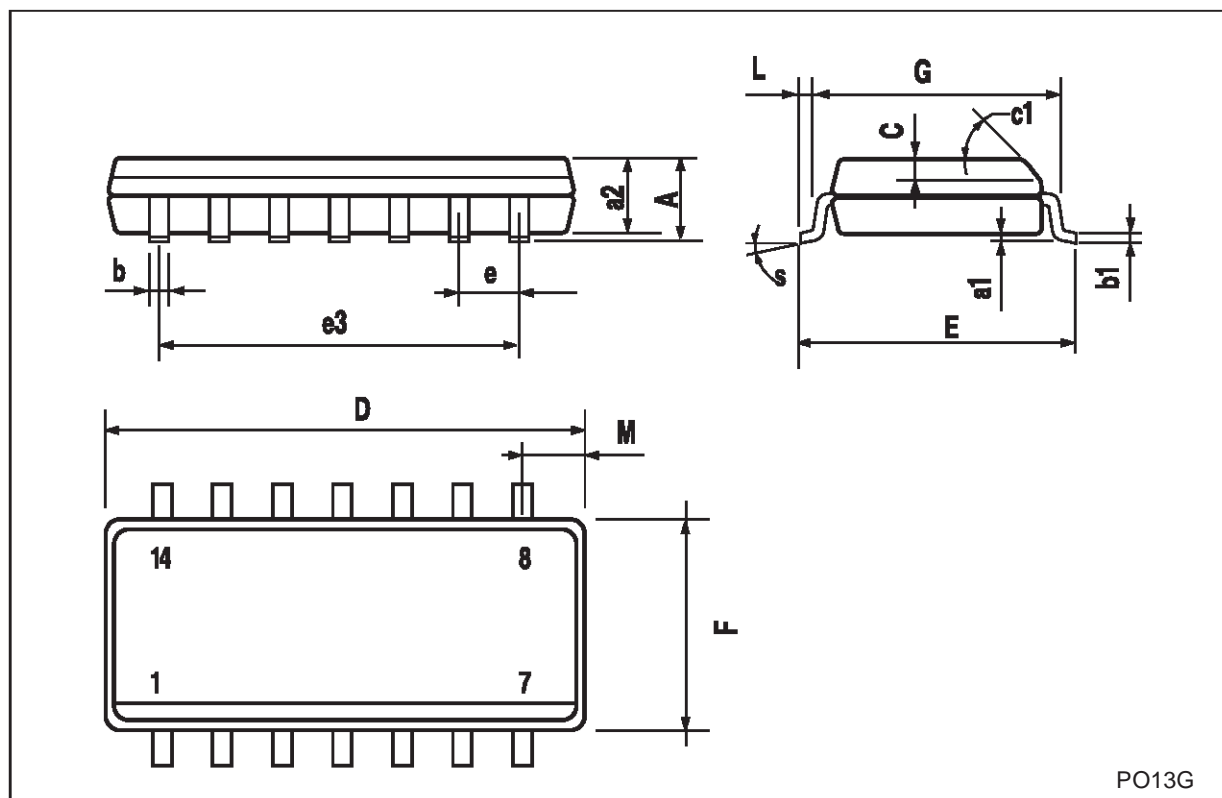

PO13G

## TSSOP14 MECHANICAL DATA

| DIM. | mm.  |          |      | inch  |            |        |
|------|------|----------|------|-------|------------|--------|
|      | MIN. | TYP      | MAX. | MIN.  | TYP.       | MAX.   |
| A    |      |          | 1.2  |       |            | 0.047  |
| A1   | 0.05 |          | 0.15 | 0.002 | 0.004      | 0.006  |
| A2   | 0.8  | 1        | 1.05 | 0.031 | 0.039      | 0.041  |
| b    | 0.19 |          | 0.30 | 0.007 |            | 0.012  |
| c    | 0.09 |          | 0.20 | 0.004 |            | 0.0089 |
| D    | 4.9  | 5        | 5.1  | 0.193 | 0.197      | 0.201  |
| E    | 6.2  | 6.4      | 6.6  | 0.244 | 0.252      | 0.260  |
| E1   | 4.3  | 4.4      | 4.48 | 0.169 | 0.173      | 0.176  |
| e    |      | 0.65 BSC |      |       | 0.0256 BSC |        |
| K    | 0°   |          | 8°   | 0°    |            | 8°     |
| L    | 0.45 | 0.60     | 0.75 | 0.018 | 0.024      | 0.030  |

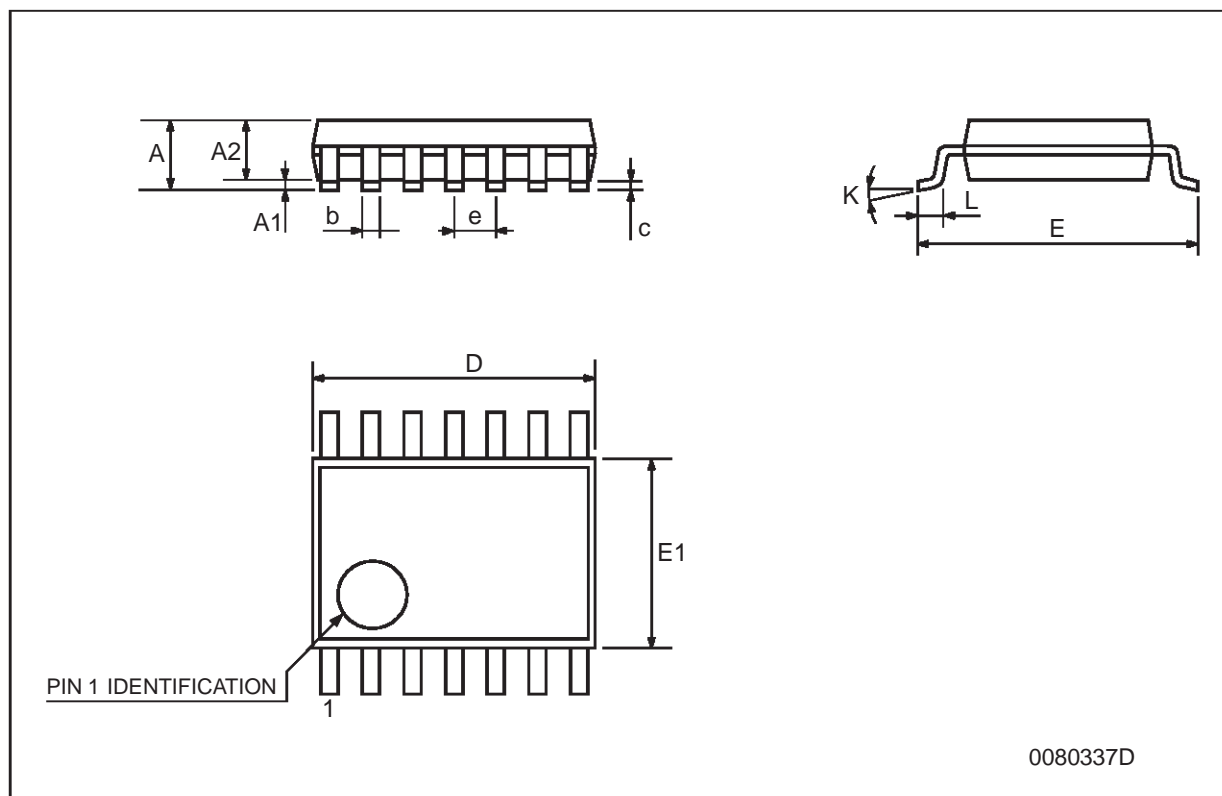

Information furnished is believed to be accurate and reliable. However, STMicroelectronics assumes no responsibility for the consequences of use of such information nor for any infringement of patents or other rights of third parties which may result from its use. No license is granted by implication or otherwise under any patent or patent rights of STMicroelectronics. Specifications mentioned in this publication are subject to change without notice. This publication supersedes and replaces all information previously supplied. STMicroelectronics products are not authorized for use as critical components in life support devices or systems without express written approval of STMicroelectronics.

© The ST logo is a registered trademark of STMicroelectronics

© 2001 STMicroelectronics - Printed in Italy - All Rights Reserved  
STMicroelectronics GROUP OF COMPANIES

Australia - Brazil - China - Finland - France - Germany - Hong Kong - India - Italy - Japan - Malaysia - Malta - Morocco  
Singapore - Spain - Sweden - Switzerland - United Kingdom

© <http://www.st.com>