

## 74VHC08 • 74VHCT08 Quad 2-Input AND Gate

### General Description

The VHC/VHCT08 is an advanced high speed CMOS 2 Input AND Gate fabricated with silicon gate CMOS technology. It achieves the high-speed operation similar to equivalent Bipolar Schottky TTL while maintaining the CMOS low power dissipation.

The internal circuit is composed of 4 stages including buffer output, which provide high noise immunity and stable output. An input protection circuit insures that 0V to 7V can be applied to the input pins without regard to the supply voltage. This device can be used to interface 5V to 3V systems and two supply systems such as battery backup. This circuit prevents device destruction due to mismatched supply and input voltages.

### Features

- Low power dissipation:  
 $I_{CC} = 2 \mu A$  (Max) @  $T_A = 25^\circ C$
  - High Speed:  
 $t_{pd} = 4.3$  ns (typ) at  $T_A = 25^\circ C$
  - High noise immunity:  
VHC  $V_{NIH} = V_{NIL} = 28\% V_{CC}$  (min)  
VHCT  $V_{IH} = 2.0V$ ,  $V_{IL} = 0.8V$
  - Power down protection:  
VHC inputs only  
VHCT inputs and outputs
  - Low noise:  
 $V_{OLP} = 0.8V$  (max)
  - Pin and function compatible with 74HC/HCT08
- Note: Add external pull up resistor to VHCT outputs to drive CMOS inputs.**

### Ordering Code:

Commercial	Package Number	Package Description
74VHC08M	M14A	14-Lead Molded JEDEC SOIC
74VHC08SJ	M14D	14-Lead Molded EIAJ SOIC
74VHC08MTC	MTC14	14-Lead Molded JEDEC Type 1 TSSOP
74VHC08N	N14A	14-Lead Molded DIP
74VHCT08M	M14A	14-Lead Molded JEDEC SOIC
74VHCT08SJ	M14D	14-Lead Molded EIAJ SOIC
74VHCT08MTC	MTC14	14-Lead Molded JEDEC Type 1 TSSOP
74VHCT08N	N14A	14-Lead Molded DIP

Surface mount packages are also available on Tape and Reel. Specify by appending the suffix letter "X" to the ordering code.

### Logic Symbol

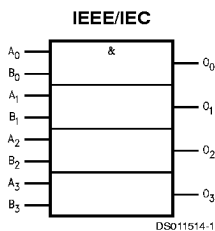

### Connection Diagram

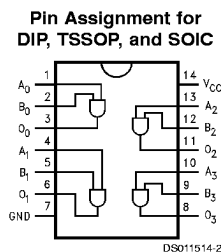

## Pin Descriptions

Pin Names	Description
$A_n, B_n$	Inputs
$O_n$	Outputs

## Truth Table

A	B	O
L	L	L
L	H	L
H	L	L
H	H	H

### Absolute Maximum Ratings (Note 1)

Supply Voltage ( $V_{CC}$ )	-0.5V to +7.0V
DC Input Voltage ( $V_{IN}$ )	-0.5V to +7.0V
DC Output Voltage ( $V_{OUT}$ )	
VHC	-0.5V to $V_{CC} + 0.5V$
VHCT (Note 2)	-0.5V to 7.0V
Input Diode Current ( $I_{IK}$ )	-20 mA
Output Diode Current ( $I_{OK}$ )	
VHC	$\pm 20$ mA
VHCT	-20 mA
DC Output Current ( $I_{OUT}$ )	$\pm 25$ mA
DC $V_{CC}/GND$ Current ( $I_{CC}$ )	$\pm 50$ mA
Storage Temperature ( $T_{STG}$ )	-65°C to +150°C
Lead Temperature ( $T_L$ )	
(Soldering, 10 seconds)	260°C

### Recommended Operating Conditions (Note 3)

Supply Voltage ( $V_{CC}$ )	
VHC	2.0V to +5.5V
VHCT	4.5V to 5.5V
Input Voltage ( $V_{IN}$ )	0V to +5.5V
Output Voltage ( $V_{OUT}$ )	0V to $V_{CC}$
Operating Temperature ( $T_{OPR}$ )	-40°C to +85°C
Input Rise and Fall Time ( $t_r, t_f$ )	
$V_{CC} = 3.3V \pm 0.3V$ (VHC only)	0 ns/V ~ 100 ns/V
$V_{CC} = 5.0V \pm 0.5V$	0 ns/V ~ 20 ns/V

**Note 1:** Absolute Maximum Ratings are values beyond which the device may be damaged or have its useful life impaired. The databook specifications should be met, without exception, to ensure that the system design is reliable over its power supply, temperature, and output/input loading variables. Fairchild does not recommend operation outside databook specifications.

**Note 2:**  $V_{OUT} > V_{CC}$  only if output is in H state.

**Note 3:** Unused inputs must be held HIGH or LOW. They may not float.

### DC Electrical Characteristics for VHC

Symbol	Parameter	$V_{CC}$ (V)	$T_A = 25^\circ C$			$T_A = -40^\circ C$ to +85°C		Units	Conditions	
			Min	Typ	Max	Min	Max			
$V_{IH}$	High Level Input Voltage	2.0 3.0-5.5	1.50 0.7 $V_{CC}$			1.50 0.7 $V_{CC}$		V		
$V_{IL}$	Low Level Input Voltage	2.0 3.0-5.5		0.50 0.3 $V_{CC}$		0.50 0.3 $V_{CC}$		V		
$V_{OH}$	High Level Output Voltage	2.0	1.9	2.0		1.9		V	$V_{IN} = V_{IH}$ or $V_{IL}$	$I_{OH} = -50 \mu A$
		3.0	2.9	3.0		2.9				
		4.5	4.4	4.5		4.4		V	$I_{OH} = -4$ mA $I_{OH} = -8$ mA	
		3.0	2.58			2.48				
4.5	3.94			3.80						
$V_{OL}$	Low Level Output Voltage	2.0		0.0	0.1		0.1	V	$V_{IN} = V_{IH}$ or $V_{IL}$	$I_{OL} = 50 \mu A$
		3.0		0.0	0.1		0.1			
		4.5		0.0	0.1		0.1	V	$I_{OL} = 4$ mA $I_{OL} = 8$ mA	
		3.0			0.36		0.44			
4.5			0.36		0.44					
$I_{IN}$	Input Leakage Current	0-5.5			$\pm 0.1$		$\pm 1.0$	$\mu A$	$V_{IN} = 5.5V$ or GND	
$I_{CC}$	Quiescent Supply Current	5.5		2.0			20.0	$\mu A$	$V_{IN} = V_{CC}$ or GND	

### Noise Characteristics for VHC

Symbol	Parameter	$V_{CC}$ (V)	$T_A = 25^\circ C$		Units	Conditions
			Typ	Limits		
$V_{OLP}$ (Note 4)	Quiet Output Maximum Dynamic $V_{OL}$	5.0	0.3	0.8	V	$C_L = 50$ pF
$V_{OLV}$ (Note 4)	Quiet Output Minimum Dynamic $V_{OL}$	5.0	-0.3	-0.8	V	$C_L = 50$ pF
$V_{IHD}$ (Note 4)	Minimum High Level Dynamic Input Voltage	5.0		3.5	V	$C_L = 50$ pF
$V_{ILD}$ (Note 4)	Maximum Low Level Dynamic Input Voltage	5.0		1.5	V	$C_L = 50$ pF

**Note 4:** Parameter guaranteed by design.

### DC Electrical Characteristics for VHCT

Symbol	Parameter	V <sub>CC</sub> (V)	T <sub>A</sub> = 25° C			T <sub>A</sub> = -40° C to +85° C		Units	Conditions
			Min	Typ	Max	Min	Max		
V <sub>IH</sub>	High Level Input Voltage	4.5 5.5	2.0			2.0		V	
V <sub>IL</sub>	Low Level Input Voltage	4.5 5.5			0.8 0.8			V	
V <sub>OH</sub>	High Level Output Voltage	4.5	3.15	3.65		3.15		V	V <sub>IN</sub> = V <sub>IH</sub> I <sub>OH</sub> = -50 μA
		4.5	2.5			2.4		V	or V <sub>IL</sub> I <sub>OH</sub> = -8 mA
V <sub>OL</sub>	Low Level Output Voltage	4.5		0.0	0.1		0.1	V	V <sub>IN</sub> = V <sub>IH</sub> I <sub>OL</sub> = 50 μA
		4.5			0.36		0.44	V	or V <sub>IL</sub> I <sub>OL</sub> = 8 mA
I <sub>IN</sub>	Input Leakage Current	0-5.5			±0.1		±1.0	μA	V <sub>IN</sub> = 5.5V or GND
I <sub>CC</sub>	Quiescent Supply Current	5.5			2.0		20.0	μA	V <sub>IN</sub> = V <sub>CC</sub> or GND
I <sub>CC(T)</sub>	Maximum I <sub>CC</sub> / Input	5.5			1.35		1.50	mA	V <sub>IN</sub> = 3.4V Other Inputs = V <sub>CC</sub> or GND
I <sub>OFF</sub>	Output Leakage Current (Power Down State)	0.0			0.5		5.0	μA	V <sub>OUT</sub> = 5.5V

### Noise Characteristics for VHCT

Symbol	Parameter	V <sub>CC</sub> (V)	T <sub>A</sub> = 25° C		Units	Conditions
			Typ	Limit		
V <sub>OLP</sub> (Note 5)	Quiet Output Maximum Dynamic V <sub>OL</sub>		0.4	0.8	V	C <sub>L</sub> = 50 pF
V <sub>OLV</sub> (Note 5)	Quiet Output Minimum Dynamic V <sub>OL</sub>		-0.4	-0.8	V	C <sub>L</sub> = 50 pF
V <sub>IHD</sub> (Note 5)	Minimum High Level Dynamic Input Voltage				V	C <sub>L</sub> = 50 pF
V <sub>ILD</sub> (Note 5)	Maximum Low Level Dynamic Input Voltage				V	C <sub>L</sub> = 50 pF

Note 5: Parameter guaranteed by design.

### AC Electrical Characteristics for VHCT

Symbol	Parameter	V <sub>CC</sub> (V)	T <sub>A</sub> = 25° C			T <sub>A</sub> = -40° C to +85° C		Units	Conditions
			Min	Typ	Max	Min	Max		
t <sub>PHL</sub>	Propagation Delay	3.3±0.3		6.2	8.8	1.0	10.5	ns	C <sub>L</sub> = 15 pF
t <sub>PLH</sub>				8.7	12.3	1.0	14.0		C <sub>L</sub> = 50 pF
		5.0±0.5		4.3	5.9	1.0	7.0	ns	C <sub>L</sub> = 15 pF
				5.8	7.9	1.0	9.0		C <sub>L</sub> = 50 pF
C <sub>IN</sub>	Input Capacitance			4	10		10	pF	V <sub>CC</sub> = Open
C <sub>PD</sub>	Power Dissipation Capacitance			18				pF	(Note 6)

Note 6: C<sub>PD</sub> is defined as the value of the internal equivalent capacitance which is calculated from the operating current consumption without load. Average operating current can be obtained by the equation: I<sub>CC (opr.)</sub> = C<sub>PD</sub> \* V<sub>CC</sub> \* f<sub>IN</sub> + I<sub>CC/4</sub> (per gate).

## AC Electrical Characteristics for VHCT

Symbol	Parameter	V <sub>CC</sub> (V)	T <sub>A</sub> = 25° C			T <sub>A</sub> = -40° C to +85° C		Units	Conditions
			Min	Typ	Max	Min	Max		
t <sub>PLH</sub>	Propagation Delay	5.0	5.0	6.9	1.0	8.0	ns	C <sub>L</sub> = 15 pF	
t <sub>PHL</sub>		±0.5	5.5	7.9	1.0	9.0		C <sub>L</sub> = 50 pF	
C <sub>IN</sub>	Input Capacitance		4	10		10	pF	V <sub>CC</sub> = Open	
C <sub>PD</sub>	Power Dissipation Capacitance		18				pF	(Note 7)	

**Note 7:** C<sub>PD</sub> is defined as the value of the internal equivalent capacitance, which is calculated from the operating current consumption without load. Average operating current can be obtained from the equation: I<sub>CC</sub> (opr.) = C<sub>PD</sub> \* V<sub>CC</sub> \* f<sub>IN</sub> + I<sub>CC</sub>/4 (per gate)

**Physical Dimensions** inches (millimeters) unless otherwise noted

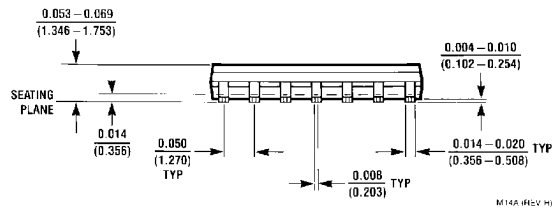
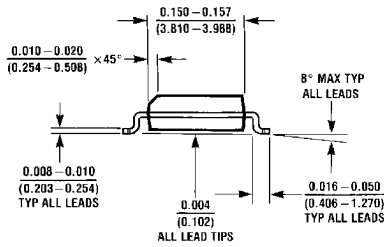
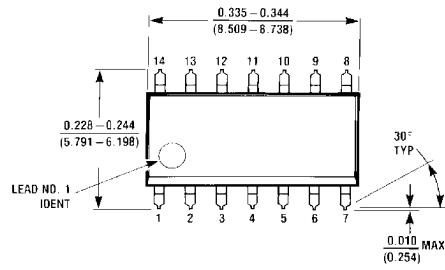

**14-Lead Small Outline Integrated Circuit—JEDEC SOIC (M)**  
Package Number M14A

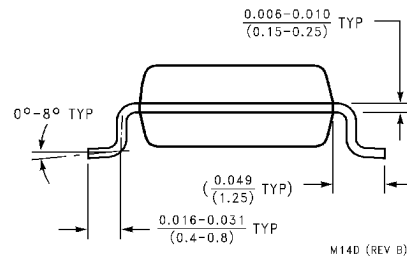
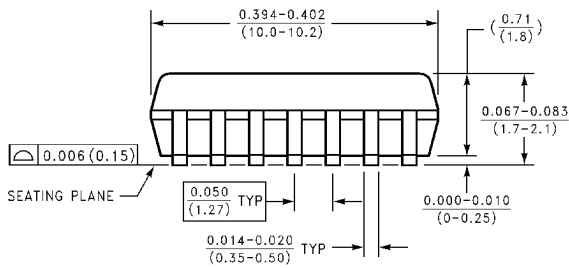
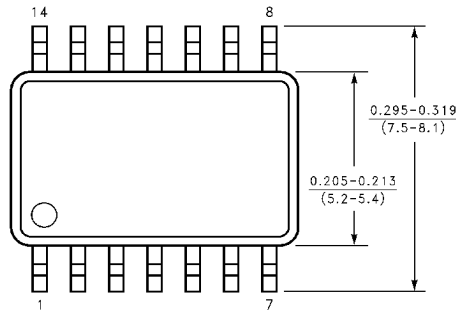

**14-Lead Plastic EIAJ SOIC (SJ)**  
Package Number M14D



**Physical Dimensions** inches (millimeters) unless otherwise noted (Continued)

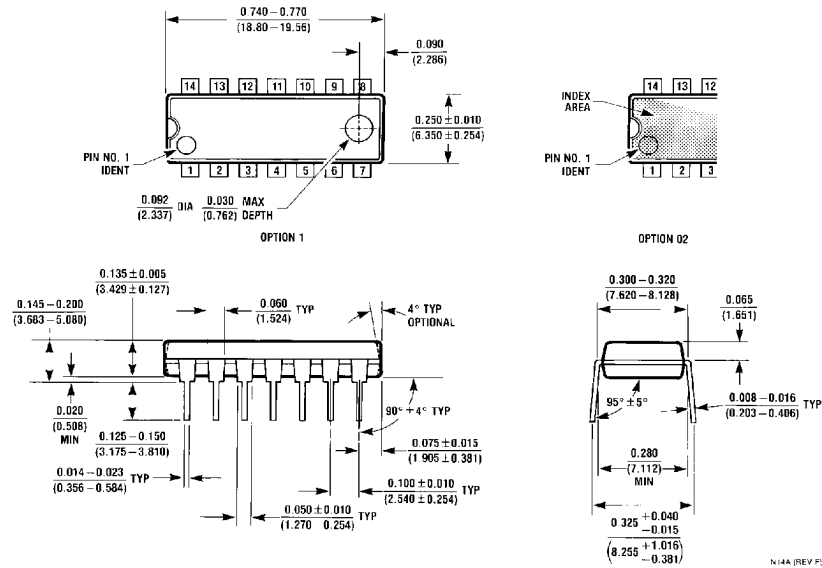

**14-Lead Molded Dual-In-Line Package (MDIP)  
Package Number N14A**

**LIFE SUPPORT POLICY**

FAIRCHILD'S PRODUCTS ARE NOT AUTHORIZED FOR USE AS CRITICAL COMPONENTS IN LIFE SUPPORT DEVICES OR SYSTEMS WITHOUT THE EXPRESS WRITTEN APPROVAL OF THE PRESIDENT OF FAIRCHILD SEMICONDUCTOR CORPORATION. As used herein:

1. Life support devices or systems are devices or systems which, (a) are intended for surgical implant into the body, or (b) support or sustain life, and (c) whose failure to perform when properly used in accordance with instructions for use provided in the labeling, can be reasonably expected to result in a significant injury to the user.
2. A critical component in any component of a life support device or system whose failure to perform can be reasonably expected to cause the failure of the life support device or system, or to affect its safety or effectiveness.

Fairchild Semiconductor Corporation  
Americas  
Customer Response Center  
Tel: 1-888-522-5372

Fairchild Semiconductor Europe  
Fax: +49 (0) 1 80-530 85 86  
Email: europe.support@nsc.com  
Deutsch Tel: +49 (0) 8 141-35-0  
English Tel: +44 (0) 1 793-85-68-56  
Italy Tel: +39 (0) 2 57 5631

Fairchild Semiconductor Hong Kong Ltd.  
13th Floor, Straight Block,  
Ocean Centre, 5 Canton Rd.  
Tsimshatsui, Kowloon  
Hong Kong  
Tel: +852 2737-7200  
Fax: +852 2314-0061

National Semiconductor Japan Ltd.  
Tel: 81-3-5620-6175  
Fax: 81-3-5620-6179

www.fairchildsemi.com

Fairchild does not assume any responsibility for use of any circuitry described, no circuit patent licenses are implied and Fairchild reserves the right at any time without notice to change said circuitry and specifications.