

**FEATURES**

- 6 Configurations
- Inductance to 11mH
- Toroidal Construction
- Up to 50 V<sub>μS</sub> E<sub>T</sub>
- Fully Encapsulated
- PCB Mounting
- Industry Standard Pinout
- Isolation to 500VDC
- UL 94V-0 Package Material

**DESCRIPTION**

The 766 series is a comprehensive range of general purpose pulse transformers. Common applications include line coupling, matching or isolating. The devices can also be used in small isolated power supplies and also as common-mode chokes in filtering applications. Please contact the technical support desk to discuss your requirements.

**SELECTION GUIDE**

Order Code	Turns Ratio ±2%	Primary Inductance <sup>1</sup> Min μH	Primary E <sub>r</sub> Constant <sup>1</sup> Min V <sub>μs</sub>	Leakage Inductance Max μH	Interwinding Capacitance Max pF	DC Resistance	Isolation Voltage Max VDC	Pin Connection Style	Mechanical Dimensions			
76600/1	1:1	2060	17.50	0.60	35	1.50	500	A	3			
76600/2	1:1	492	8.50	0.30	20	0.80						
76600/3	1:1	219	5.50	0.25	12	0.50						
76600/4	1:1	50	4.00	0.20	10	0.40						
76601/1	1:1	2060	17.5	0.60	35	1.50	500	B		3		
76601/2	1:1	492	8.50	0.30	20	0.80						
76601/3	1:1	219	5.50	0.25	12	0.50						
76601/4	1:1	50	4	0.20	10	0.40						
76601/6	1:1	9.5	6	0.20	10	0.40						
76601/8	1:1	1000	12	0.30	25	0.30						
76601/9	1:1	11mH	51	65	5	5.00						
76601/16	1:1	4000	50	0.60	45	1.50						
76601/20	1:1	20.1	2.5	0.20	5	0.20						
76601/23	1:1	938	10.5	0.20	35	0.15						
76601/24	1:1	11.7mH	50.5	0.40	80	1.35						
76602/1	1:1:1	2060	17.5	0.60	35	1.50			500		C	1
76602/2	1:1:1	492	8.5	0.30	20	0.80						
76602/3	1:1:1	219	5.5	0.25	12	0.50						
76602/5	1:1:1	23	2.5	0.20	8	0.30						
76602/6	1:1:1	9.5	6	0.20	10	0.40						
76602/8	1:1:1	469	10.5	3.50	3	0.40						
76602/9	1:1:1	5870	37.5	0.90	60	1.70						
76603/3	2:1	219	5.5	0.60	8	0.50	500	G		3		
76604/1	2:1	1970	17	1.60	20	1.50	500	B		3		
76605/1	2:1:1	2160	18	1.60	20	1.50	500	D	1			
76605/2	2:1:1	540	9	0.80	10	0.80						
76605/6	2:1:1	9.5	6	0.40	8	0.40						
76606/1	3:1	1970	17	1.80	15	1.50	500	G	3			
76607/3	3:1	251	6	1.00	5	0.50	500	B	3			
76608/9	3:3:2	400	9.5	0.50	15	0.20	500	H	1			
76610/1	4:1	2160	18	2.80	12	1.50	500	B	3			
76610/4	4:1	90	5	1.00	5	0.40						
76610/6	4:1	9.5	6	1.20	5	0.40						
76613/1	1cr:1	1970	17	0.70	36	1.60	500	E	2			
76613/2	1cr:1	540	9	0.40	22	0.90						
76613/3	1cr:1	219	5.5	0.30	13	0.60						
76614/1	2cr:1	1970	17	1.00	35	1.50						
76614/3	2cr:1	125	6	0.50	12	0.50						
76615/1	1cr:1cr	3200	45	2.00	27	1.00	500	F	1			
76615/6	1cr:1cr	400	9.5	85	3	0.30						
76616/1	1cr:2cr	1800	15.5	1.00	20	1.00						
76616/3	2cr:1cr	4350	23	3.00	20	1.00						
76616/8	1cr:2cr	7600	30.5	0.80	25	1.80						

**ABSOLUTE MAXIMUM RATINGS**

Operating free air temperature range	0°C to 70°C
Storage temperature range	-60°C to 125°C
Lead Temperature 1.5mm from case for 10 seconds	300°C
Isolation voltage (flash tested for 1 second)	500VDC

<sup>1</sup> Measured at 10kHz, 10mV  
All specifications typical at T<sub>A</sub> = 25°C

# 766 SERIES

## Pulse Transformers

### MECHANICAL DIMENSIONS (6 PIN DIP PACKAGE STYLE)

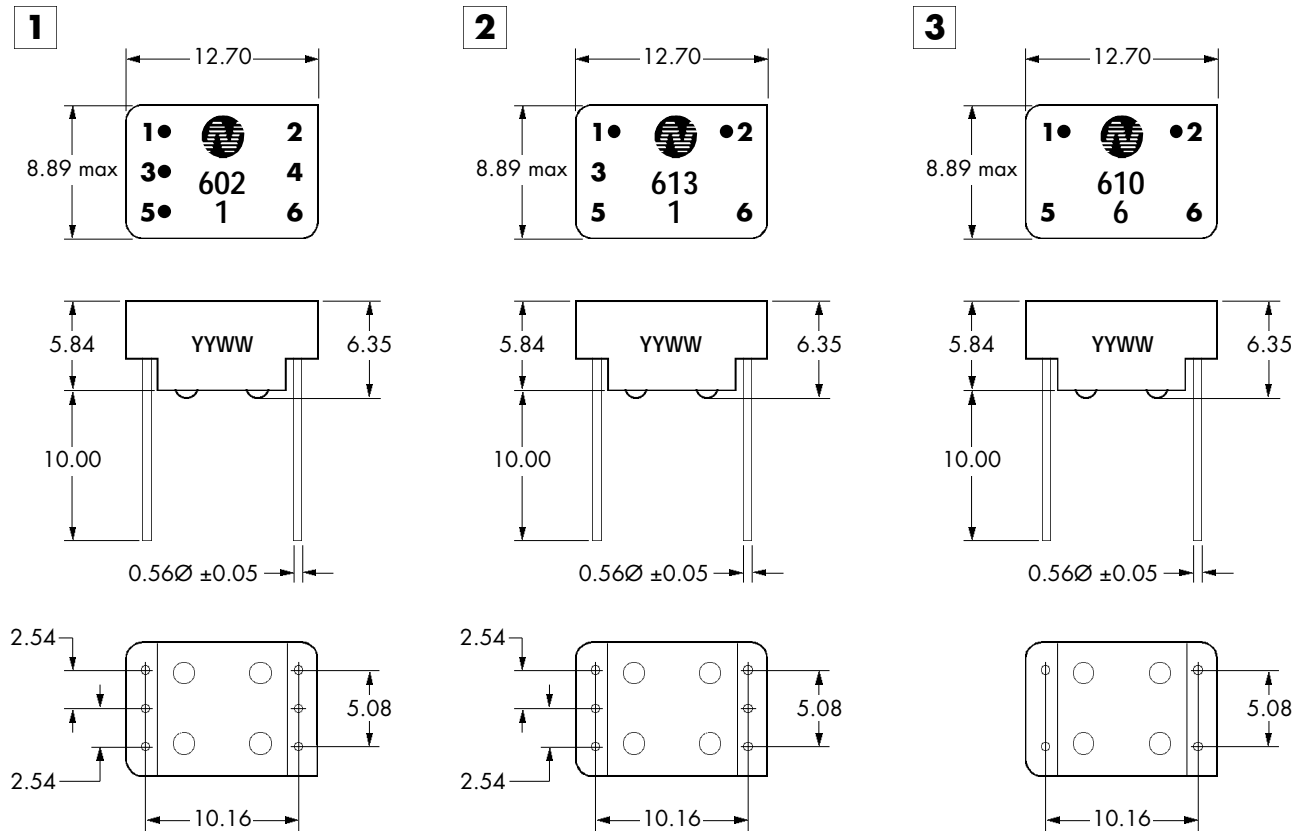

All dimensions in mm XX.XX  $\pm 0.25$ mm. All pins on a 2.54mm pitch and within  $\pm 0.25$ mm of true position.

### PIN CONNECTION STYLE (6 PIN DIP - TOP VIEW)

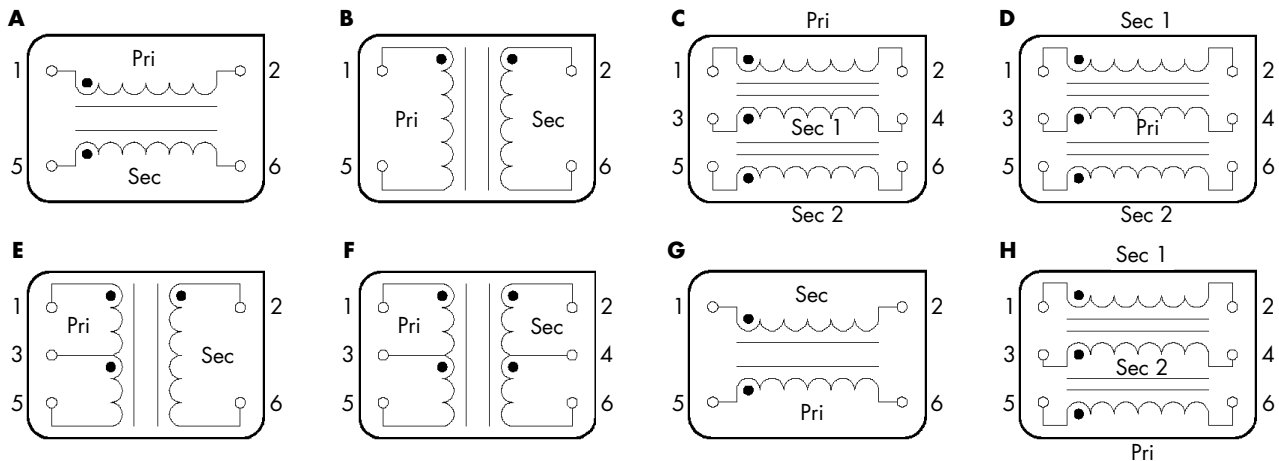

C&D Technologies (NCL) Limited reserve the right to alter or improve the specification, internal design or manufacturing process at any time, without notice. Please check with your supplier or visit our web site to ensure that you have the current and complete specification for your product before use.

© C&D Technologies (NCL) Limited 2002

NMP 766.4

No part of this publication may be copied, transmitted or stored in a retrieval system or reproduced in any way including, but not limited to, photography, photocopy, magnetic or other recording means, without prior written permission from C&D Technologies (NCL) Limited.

Instructions for use are available from [www.dc-dc.com](http://www.dc-dc.com)

**C&D Technologies (NCL) Ltd**  
Tanners Drive, Blakelands North  
Milton Keynes MK14 5BU, England  
Tel: +44 (0)1908 615232  
Fax: +44 (0)1908 617545  
email: [info@cdtechno-ncl.com](mailto:info@cdtechno-ncl.com)

**www:** <http://www.dc-dc.com>

**C&D Technologies Inc.**  
Power Electronics Division  
3400 E Britannia Drive,  
Tucson, Arizona 85706 USA.  
Tel: +1(800) 547-2537  
Fax: +1(800) 770-9369  
email: [info@cdtechno-ncl.com](mailto:info@cdtechno-ncl.com)

**C&D TECHNOLOGIES**  
Power Solutions