

REVISIONS			
REV.	DESCRIPTION	ECN NO.	DATE
01	FIRST RELEASE	N/A	11/28/14

When ordering, please add suffix "T" to the part number for tape & reel packaging (330mm reel).

PAGE 4 & 5 ARE FOR INTERNAL ONLY

PART NUMBER	PART DESCRIPTION
821-02085F	RoHS compliant per EU Directive 2011/65/EU

TITLE	TRANSFORMER, T1/E1/CEPT/ISDN-PRI, DUAL, SMD, 16 PIN
-------	---

WARNING !
 ALL SHEETS OF THIS DOCUMENT ARE CONTROLLED DOCUMENTATION AND ARE NOT TO BE RELEASED OUTSIDE OF E&E OR ITS SUB-CONTRACTORS WITHOUT AUTHORIZATION.

UNLESS OTHERWISE SPECIFIED, DIMENSIONS ARE IN INCH/mm.

TOLERANCE ARE:

INCH	mm	ANGLE
.XXX ± .005	.XX ± 0.13	X.X ± 0.3
.XX ± .02	.X ± 0.5	X. ± 1

APPROVALS	DATE
DRAWN BY Y.L. YUNG	11/28/14
PROJ. ENG Y.L. YUNG	11/28/14
APPROVED BY D. YUNG	11/28/14
Q.A. D. LUO	11/28/14

 E & E Magnetic Products Ltd.	
DRAWING NO./MODEL	REV
821-02085F	01
SCALE	PAGE OF
DO NOT SCALE	1 OF 5

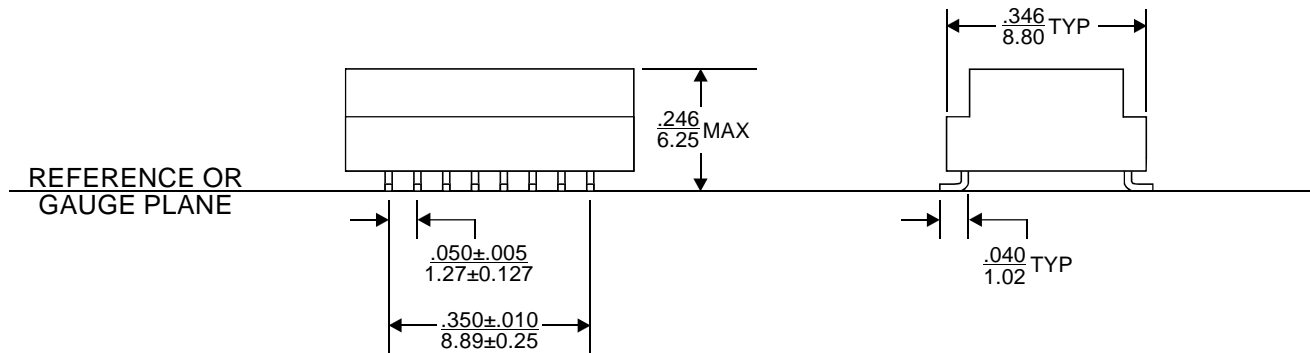
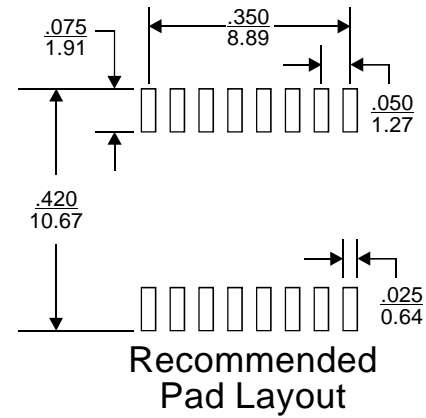
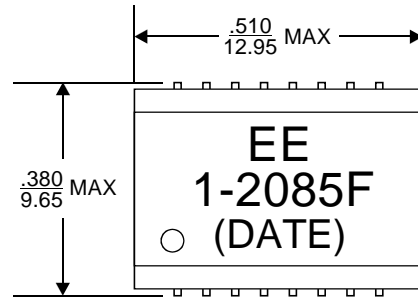

1. Dimensions are specified in $\frac{\text{inches}}{\text{mm}}$ with higher precedence in inches.
2. Unless otherwise specified, all tolerances are $\pm .010$ inches (0.25 mm).
3. Coplanarity: $\frac{.004}{0.10}$ max.
4. "(DATE)" includes at least the manufacturing date code (in YYWW format) plus two character country code.

MECHANICAL OUTLINE



E & E Magnetic Products Ltd.

DRAWING NO./MODEL

821-02085F

REV

01

SCALE

DO NOT SCALE

PAGE

OF

2

5

5

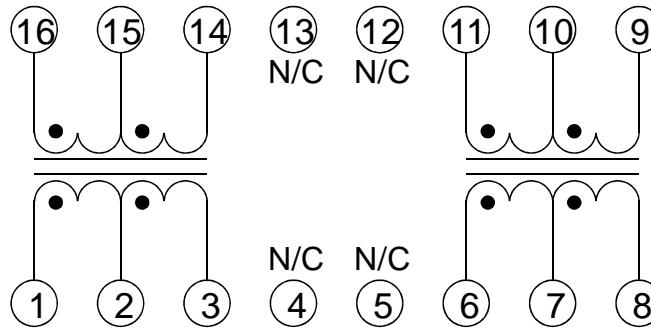

SCHEMATIC

ELECTRICAL SPECIFICATION @25°C:

PARAMETERS	UNIT	LIMITS
Turns Ratio(16-15-14):(1-2-3)	-	1CT : 2.3CT ± 2%
Turns Ratio(6-7-8):(11-10-9)	-	1CT : 1CT ± 2%
Polarity	-	Per Schematic
OCL(16-14) @10kHz, 0.1Vrms	mH	1.2 Typ
OCL(6-8) @10kHz, 0.1Vrms	mH	1.2 Typ
LL(16-14), short 1,2,3 @100kHz, 1.0Vrms	uH	0.5 Max
LL(6-8), short 11,10,9 @100kHz, 1.0Vrms	uH	0.5 Max
Cww(16-14):(1-3) @100kHz, 1.0Vrms	pF	40 Max
Cww(6-8):(11-9) @100kHz, 1.0Vrms	pF	40 Max
DCR(16-14)	Ω	0.9 Max
DCR(6-8)	Ω	0.9 Max
Isolation(16-14):(1-3)	Vrms	1500 Min
Isolation(6-8):(11-9)	Vrms	1500 Min

5. Operating Temperature: 0°C to +70°C.

E & E Magnetic Products Ltd.	
DRAWING NO./MODEL	REV
821-02085F	01
SCALE	PAGE OF
DO NOT SCALE	3 OF 5