



Intel[®] 440BX AGPset: 82443BX Host Bridge/Controller

Datasheet

April 1998

Order Number: 290633-001





Information in this document is provided in connection with Intel products. No license, express or implied, by estoppel or otherwise, to any intellectual property rights is granted by this document. Except as provided in Intel's Terms and Conditions of Sale for such products, Intel assumes no liability whatsoever, and Intel disclaims any express or implied warranty, relating to sale and/or use of Intel products including liability or warranties relating to fitness for a particular purpose, merchantability, or infringement of any patent, copyright or other intellectual property right. Intel products are not intended for use in medical, life saving, or life sustaining applications.

Intel may make changes to specifications and product descriptions at any time, without notice.

Contact your local Intel sales office or your distributor to obtain the latest specifications and before placing your product order.

The 82443BX chipset may contain design defects or errors known as errata which may cause the product to deviate from published specifications. Current characterized errata are available upon request.

I²C is a two-wire communications bus/protocol developed by Philips. SMBus is a subset of the I²C bus/protocol and was developed by Intel. Implementations of the I²C bus/protocol or the SMBus bus/protocol may require licenses from various entities, including Philips Electronics N.V. and North American Philips Corporation.

Copies of documents which have an ordering number and are referenced in this document, or other Intel literature may be obtained by:

calling 1-800-548-4725 or

by visiting Intel's website at <http://www.intel.com>.

Copyright © Intel Corporation, 1997-1998

*Third-party brands and names are the property of their respective owners.



Intel 82443BX Features

- Processor/host bus support
 - Optimized for Pentium® II processor at 100 MHz system bus frequency; Support for 66 MHz
 - Supports full symmetric Multiprocessor (SMP) Protocol for up to two processors; I/O APIC related buffer management support (WSC# signal)
 - In-order transaction and dynamic deferred transaction support
 - Desktop optimized GTL+ bus driver technology (gated GTL+ receivers for reduced power)
- Integrated DRAM controller
 - 8 to 512 Mbytes or 1GB (with registered DIMMs)
 - Supports up to 4 double-sided DIMMs (8 rows memory)
 - 64-bit data interface with ECC support (SDRAM only)
 - Unbuffered and Registered SDRAM (Synchronous) DRAM Support (x-1-1-1 access @ 66 MHz, x-1-1-1 access @ 100 MHz)
 - Enhanced SDRAM Open Page Architecture Support for 16- and 64-Mbit DRAM devices with 2k, 4k and 8k page sizes
- PCI bus interface
 - PCI Rev. 2.1, 3.3V and 5V, 33MHz interface compliant
 - PCI Parity Generation Support
 - Data streaming support from PCI to DRAM
 - Delayed Transaction support for PCI-DRAM Reads
 - Supports concurrent CPU, AGP and PCI transactions to main memory
- AGP interface
 - Supports single AGP compliant device (AGP-66/133 3.3V device)
 - AGP Specification Rev 1.0 compliant
 - AGP-data/transaction flow optimized arbitration mechanism
 - AGP side-band interface for efficient request pipelining without interfering with the data streams
 - AGP-specific data buffering
 - Supports concurrent CPU, AGP and PCI transactions to main memory
 - AGP high-priority transactions (“expedite”) support
- Power Management Functions
 - Stop Clock Grant and Halt special cycle translation (host to PCI Bus)
 - Mobile and “Deep Green” Desktop support for system suspend/resume (i.e., DRAM and power-on suspend)
 - Dynamic power down of idle DRAM rows
 - SDRAM self-refresh power down support in suspend mode
 - Independent, internal dynamic clock gating reduces average power dissipation
 - Static STOP CLOCK support
 - Power-on Suspend mode
 - Suspend to DRAM
 - ACPI compliant power management
- Packaging/Voltage
 - 492 Pin BGA
 - 3.3V core and mixed 3.3V and GTL I/O
- Supporting I/O Bridge
 - System Management Bus (SMB) with support for DIMM Serial Presence Detect (SPD)
 - PCI-ISA Bridge (PIIX4E)
 - Power Management Support
 - 3.3V core and mixed 5V, 3.3V I/O and interface to the 2.5V CPU signals via open-drain output buffers

The Intel® 440BX AGPset is intended for the Pentium® II processor platform and emerging 3D graphics/multimedia applications. The 82443BX Host Bridge provides a Host-to-PCI bridge, optimized DRAM controller and data path, and an Accelerated Graphic Port (AGP) interface. AGP is a high performance, component level interconnect targeted at 3D graphics applications and is based on a set of performance enhancements to PCI.

The Intel 82443BX may contain design defects or errors known as errata which may cause the products to deviate from published specifications. Current characterized errata are available on request.

The I/O subsystem portion of the Intel® 440BX AGPset platform is based on the 82371EB (PIIX4E), a highly integrated version of the Intel's PCI-ISA bridge family. The Intel® 440BX AGPset is ideal for the Mobile AGPset Pentium II processor platforms; providing full support for all system suspend modes and segmented power planes.

Intel 82443BX Simplified Block Diagram

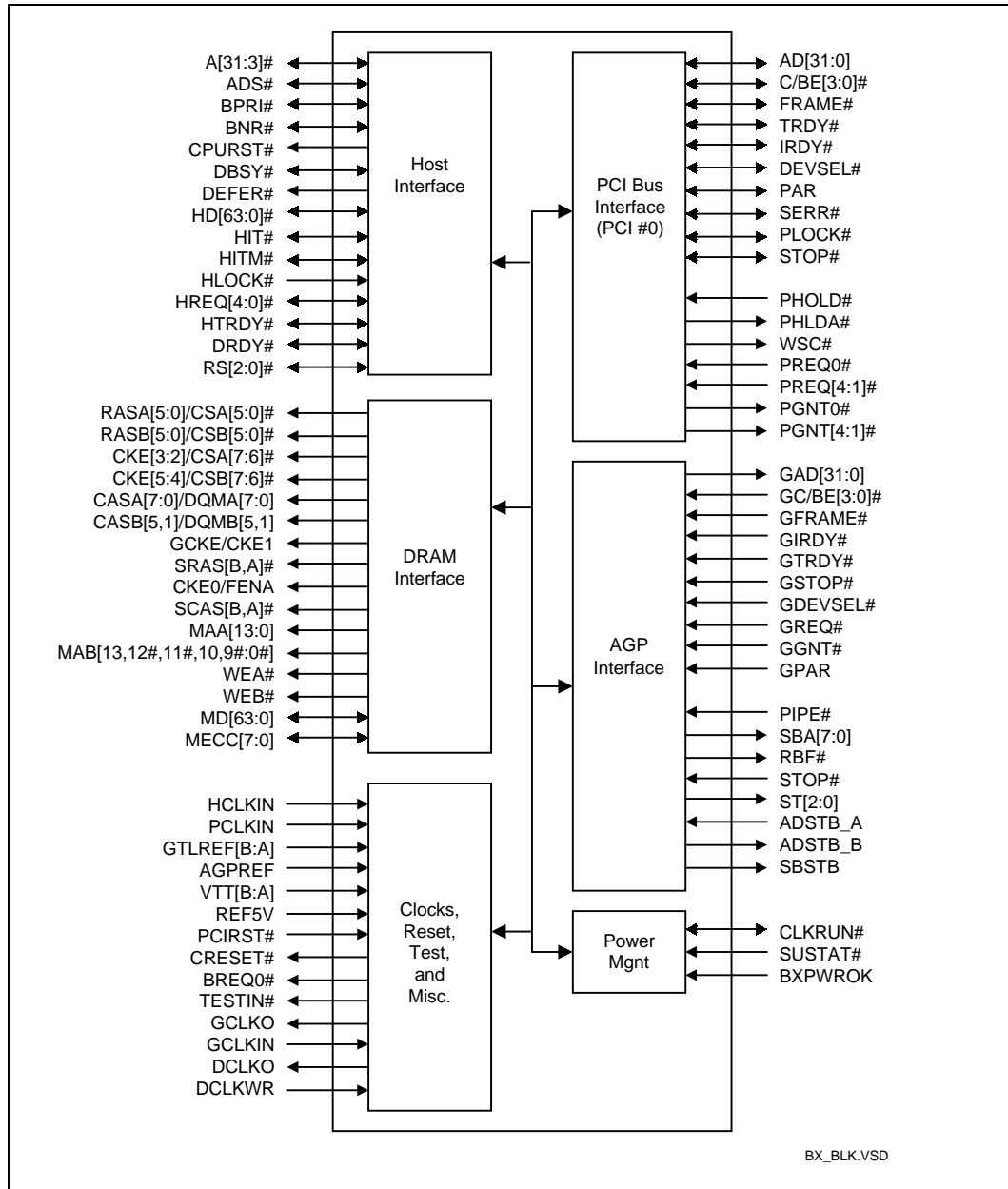



Contents

1	Architectural Overview.....	1-1
2	Signal Description.....	2-1
	2.1 Host Interface Signals.....	2-1
	2.2 DRAM Interface.....	2-3
	2.3 PCI Interface (Primary).....	2-5
	2.4 Primary PCI Sideband Interface.....	2-6
	2.5 AGP Interface Signals.....	2-7
	2.6 Clocks, Reset, and Miscellaneous.....	2-9
	2.7 Power-Up/Reset Strap Options.....	2-10
3	Register Description.....	3-1
	3.1 I/O Mapped Registers.....	3-2
	3.1.1 CONFADD—Configuration Address Register.....	3-2
	3.1.2 CONFDATA—Configuration Data Register.....	3-3
	3.1.3 PM2_CTL—ACPI Power Control 2 Control Register.....	3-4
	3.2 PCI Configuration Space Access.....	3-4
	3.2.1 Configuration Space Mechanism Overview.....	3-5
	3.2.2 Routing the Configuration Accesses to PCI or AGP.....	3-5
	3.2.3 PCI Bus Configuration Mechanism Overview.....	3-6
	3.2.3.1 Type 0 Access.....	3-6
	3.2.3.2 Type 1 Access.....	3-6
	3.2.4 AGP Bus Configuration Mechanism Overview.....	3-6
	3.2.5 Mapping of Configuration Cycles on AGP.....	3-7
	3.3 Host-to-PCI Bridge Registers (Device 0).....	3-8
	3.3.1 VID—Vendor Identification Register (Device 0).....	3-10
	3.3.2 DID—Device Identification Register (Device 0).....	3-10
	3.3.3 PCICMD—PCI Command Register (Device 0).....	3-11
	3.3.4 PCISTS—PCI Status Register (Device 0).....	3-12
	3.3.5 RID—Revision Identification Register (Device 0).....	3-13
	3.3.6 SUBC—Sub-Class Code Register (Device 0).....	3-13
	3.3.7 BCC—Base Class Code Register (Device 0).....	3-13
	3.3.8 MLT—Master Latency Timer Register (Device 0).....	3-14
	3.3.9 HDR—Header Type Register (Device 0).....	3-14
	3.3.10 APBASE—Aperture Base Configuration Register (Device 0).....	3-14
	3.3.11 SVID—Subsystem Vendor Identification Register (Device 0).....	3-15
	3.3.12 SID—Subsystem Identification Register (Device 0).....	3-16
	3.3.13 CAPPTR—Capabilities Pointer Register (Device 0).....	3-16
	3.3.14 NBXCFG—NBX Configuration Register (Device 0).....	3-16
	3.3.15 DRAMC—DRAM Control Register (Device 0).....	3-19
	3.3.16 DRAMT—DRAM Timing Register (Device 0).....	3-20
	3.3.17 PAM[6:0]—Programmable Attribute Map Registers(Device 0).....	3-20
	3.3.18 DRB[0:7]—DRAM Row Boundary Registers (Device 0).....	3-22
	3.3.19 FDHC—Fixed DRAM Hole Control Register (Device 0).....	3-24
	3.3.20 MBSC—Memory Buffer Strength Control Register (Device 0).....	3-25
	3.3.21 SMRAM—System Management RAM Control Register (Device 0).....	3-28

3.3.22	ESMRAMC—Extended System Management RAM Control Register (Device 0)	3-29
3.3.23	RPS—SDRAM Row Page Size Register (Device 0).....	3-30
3.3.24	SDRAMC—SDRAM Control Register (Device 0)	3-30
3.3.25	PGPOL—Paging Policy Register (Device 0)	3-32
3.3.26	PMCR—Power Management Control Register (Device 0)	3-33
3.3.27	SCRR—Suspend CBR Refresh Rate Register (Device 0)	3-34
3.3.28	EAP—Error Address Pointer Register (Device 0).....	3-35
3.3.29	ERRCMD—Error Command Register (Device 0)	3-36
3.3.30	ERRSTS—Error Status Register (Device 0).....	3-37
3.3.31	ACAPID—AGP Capability Identifier Register (Device 0)	3-38
3.3.32	AGPSTAT—AGP Status Register (Device 0).....	3-38
3.3.33	AGPCMD—AGP Command Register (Device 0).....	3-39
3.3.34	AGPCTRL—AGP Control Register (Device 0)	3-40
3.3.35	APSIZE—Aperture Size Register (Device 0).....	3-41
3.3.36	ATTBASE—Aperture Translation Table Base Register (Device 0)	3-41
3.3.37	MBFS—Memory Buffer Frequency Select Register (Device 0)	3-42
3.3.38	BSPAD—BIOS Scratch Pad Register (Device 0)	3-44
3.3.39	DWTC—DRAM Write Thermal Throttling Control Register (Device 0)	3-45
3.3.40	DRTC—DRAM Read Thermal Throttling Control Register (Device 0)	3-46
3.3.41	BUFFC—Buffer Control Register (Device 0)	3-47
3.4	PCI-to-PCI Bridge Registers (Device 1)	3-48
3.4.1	VID1—Vendor Identification Register (Device 1).....	3-49
3.4.2	DID1—Device Identification Register (Device 1)	3-49
3.4.3	PCICMD1—PCI-to-PCI Command Register (Device 1)	3-50
3.4.4	PCISTS1—PCI-to-PCI Status Register (Device 1)	3-51
3.4.5	RID1—Revision Identification Register (Device 1)	3-51
3.4.6	SUBC1—Sub-Class Code Register (Device 1)	3-52
3.4.7	BCC1—Base Class Code Register (Device 1)	3-52
3.4.8	MLT1—Master Latency Timer Register (Device 1).....	3-52
3.4.9	HDR1—Header Type Register (Device 1).....	3-53
3.4.10	PBUSN—Primary Bus Number Register (Device 1).....	3-53
3.4.11	SBUSN—Secondary Bus Number Register (Device 1)	3-53
3.4.12	SUBUSN—Subordinate Bus Number Register (Device 1)	3-54
3.4.13	SMLT—Secondary Master Latency Timer Register (Device 1)	3-54
3.4.14	IOBASE—I/O Base Address Register (Device 1).....	3-54
3.4.15	IOLIMIT—I/O Limit Address Register (Device 1).....	3-55
3.4.16	SSTS—Secondary PCI-to-PCI Status Register (Device 1)	3-56
3.4.17	MBASE—Memory Base Address Register (Device 1).....	3-57
3.4.18	MLIMIT—Memory Limit Address Register (Device 1).....	3-57
3.4.19	PMBASE—Prefetchable Memory Base Address Register (Device 1)	3-58
3.4.20	PMLIMIT—Prefetchable Memory Limit Address Register (Device 1)	3-58
3.4.21	BCTRL—PCI-to-PCI Bridge Control Register (Device 1)	3-59



Functional Description	4-1
4.1 System Address Map	4-1
4.1.1 Memory Address Ranges	4-2
4.1.1.1 Compatibility Area	4-3
4.1.1.2 Extended Memory Area	4-4
4.1.1.3 AGP Memory Address Range	4-6
4.1.1.4 AGP DRAM Graphics Aperture	4-6
4.1.1.5 System Management Mode (SMM) Memory Range	4-6
4.1.2 Memory Shadowing	4-8
4.1.3 I/O Address Space	4-8
4.1.4 AGP I/O Address Mapping	4-8
4.1.5 Decode Rules and Cross-Bridge Address Mapping	4-9
4.1.5.1 PCI Interface Decode Rules	4-9
4.1.5.2 AGP Interface Decode Rules	4-9
4.1.5.3 Legacy VGA Ranges	4-10
4.2 Host Interface	4-10
4.2.1 Host Bus Device Support	4-10
4.2.2 Symmetric Multiprocessor (SMP) Protocol Support	4-13
4.2.3 In-Order Queue Pipelining	4-13
4.2.4 Frame Buffer Memory Support (USWC)	4-13
4.3 DRAM Interface	4-14
4.3.1 DRAM Organization and Configuration	4-14
4.3.1.1 Configuration Mechanism For DIMMS	4-19
4.3.2 DRAM Address Translation and Decoding	4-20
4.3.3 SDRAMC Register Programming	4-23
4.3.4 DRAMT Register Programming	4-23
4.3.5 SDRAM Paging Policy	4-24
4.4 PCI Interface	4-24
4.5 AGP Interface	4-24
4.6 Data Integrity Support	4-25
4.6.1 Data Integrity Mode Selection	4-25
4.6.1.1 Non-ECC (Default Mode of Operation)	4-25
4.6.1.2 EC Mode	4-25
4.6.1.3 ECC Mode	4-25
4.6.1.4 ECC Generation and Error Detection/Correction and Reporting	4-26
4.6.1.5 Optimum ECC Coverage	4-27
4.6.2 DRAM ECC Error Signaling Mechanism	4-27
4.6.3 CPU Bus Integrity	4-27
4.6.4 PCI Bus Integrity	4-27
4.7 System Clocking	4-28
4.8 Power Management	4-28
4.8.1 Overview	4-28
4.8.2 82443BX Reset	4-32
4.8.2.1 CPU Reset	4-33
4.8.2.2 CPU Clock Ratio Straps	4-33
4.8.2.3 82443BX Straps	4-34
4.8.3 Suspend Resume	4-34
4.8.3.1 Suspend Resume protocols	4-34
4.8.3.2 Suspend Refresh	4-34
4.8.4 Clock Control Functions	4-35
4.8.5 SDRAM Power Down Mode	4-36

	4.8.6	SMRAM	4-36
5		Pinout and Package Information.....	5-1
	5.1	82443BX Pinout.....	5-1
	5.2	Package Dimensions	5-8

Figures

1-1	Intel [®] 440BX AGPset System Block Diagram	1-2
3-1	82443BX PCI Bus Hierarchy	3-5
3-2	SDRAM DIMMs and Corresponding DRB Registers	3-23
4-1	Memory System Address Space	4-2
4-2	Four-DIMM Configuration with FET switches	4-16
4-3	Three-DIMM SDRAM Configuration	4-17
4-4	Three-SODIMMs EDO Configuration	4-18
4-5	Three-SODIMMs SDRAM Configuration	4-19
4-6	Typical Intel [®] 440BX AGPset System Clocking.....	4-28
4-7	Reset CPURST# in a Desktop or Mobile System When PCIRST# Asserted	4-33
4-8	External Glue Logic Drives CPU Clock Ratio Straps.....	4-34
5-1	82443BX Pinout (Top View—left side)	5-2
5-2	82443BX Pinout (Top View—right side).....	5-3
5-3	82443BX BGA Package Dimensions—Top and Side Views	5-8
5-4	82443BX BGA Package Dimensions—Bottom Views	5-9



Tables

2-1	Host Interface Signals.....	2-1
2-2	Host Signals Not supported by the 82443BX.....	2-3
2-3	DRAM Interface Signals.....	2-3
2-4	Primary PCI Interface Signals.....	2-5
2-5	Primary PCI Sideband Interface Signals.....	2-6
2-6	AGP Interface Signals.....	2-7
2-7	Clocks, Reset, and Miscellaneous	2-9
2-8	Power Management Interface.....	2-9
2-9	Reference Pins	2-10
2-10	Strapping Options	2-11
3-1	82443BX Register Map — Device 0	3-8
3-2	Attribute Bit Assignment.....	3-21
3-3	PAM Registers and Associated Memory Segments	3-21
3-4	82443BX Configuration Space—Device 1	3-48
4-1	Memory Segments and their Attributes.....	4-3
4-2	SMRAM Decoding	4-7
4-3	SMRAM Range Decode.....	4-7
4-4	SMRAM Decode Control.....	4-7
4-5	Host Bus Transactions Supported By 82443BX	4-11
4-6	Host Responses supported by the 82443BX	4-12
4-7	Host Special Cycles with 82443BX.....	4-12
4-8	Sample Of Possible Mix And Match Options For 6 Row/3 DIMM Configurations	4-15
4-9	Data Bytes on DIMM Used for Programming DRAM Registers	4-20
4-10	Supported Memory Configurations	4-21
4-11	MA Muxing vs. DRAM Address Split.....	4-22
4-12	Programmable SDRAM Timing Parameters	4-23
4-13	EDO DRAM Timing Parameters	4-23
4-14	Low Power Mode	4-31
4-15	AGPset Reset	4-32
4-16	Reset Signals.....	4-32
4-17	Suspend / Resume Events and Activities	4-34
4-18	SDRAM Suspend Refresh Configuration Modes	4-35
5-1	82443BX Alphabetical BGA Pin List	5-4
5-2	82443BX Package Dimensions (492 BGA)	5-9

The Intel® 440BX AGPset includes the 82443BX Host Bridge and the 82371EB PIIX4E for the I/O subsystem. The 82443BX functions and capabilities include:

- Support for single and dual Pentium II processor configurations
- 64-bit GTL+ based Host Bus Interface
- 32-bit Host address Support
- 64-bit Main Memory Interface with optimized support for SDRAM at 100 and 66/60 MHz
- 32-bit Primary PCI Bus Interface (PCI) with integrated PCI arbiter
- AGP Interface (AGP) with 133 MHz data transfer capability configurable as a Secondary PCI Bus
- Extensive Data Buffering between all interfaces for high throughput and concurrent operations
- Mobile and “Deep Green” Desktop power management support

Figure 1-1 shows a block diagram of a typical platform based on the Intel® 440BX AGPset. The 82443BX host bus interface supports up to two Pentium II processors at the maximum bus frequency of 100 MHz. The physical interface design is based on the GTL+ specification optimized for the desktop. The 82443BX provides an optimized 64-bit DRAM interface. This interface is implemented as a 3.3V-only interface that supports only 3V DRAM technology. Two copies of the MA, and CS# signals drive a maximum of two DIMMs each; providing unbuffered high performance at 100 MHz. The 82443BX provides interface to PCI operating at 33 MHz. This interface implementation is compliant with PCI Rev 2.1 Specification. The 82443BX AGP interface implementation is based on Rev 1.0 of the AGP Specification. The AGP interface supports 133 MHz data transfer rates and can be used as a Secondary PCI interface operating at 66 MHz/3.3V supporting only a single PCI agent.

The 82443BX is designed to support the PIIX4E I/O bridge. PIIX4E is a highly integrated multifunctional component supporting the following functions and capabilities:

- PCI Rev 2.1 compliant PCI-ISA Bridge with support for both 3.3V and 5V 33 MHz PCI operations
- Deep Green Desktop Power Management Support
- Mobile Power Management Support
- Enhanced DMA controller and Interrupt Controller and Timer functions
- Integrated IDE controller with Ultra DMA/33 support
- USB host interface with support for 2 USB ports
- System Management Bus (SMB) with support for DIMM Serial PD
- Support for an external I/O APIC component

Figure 1-1. Intel® 440BX AGPset System Block Diagram

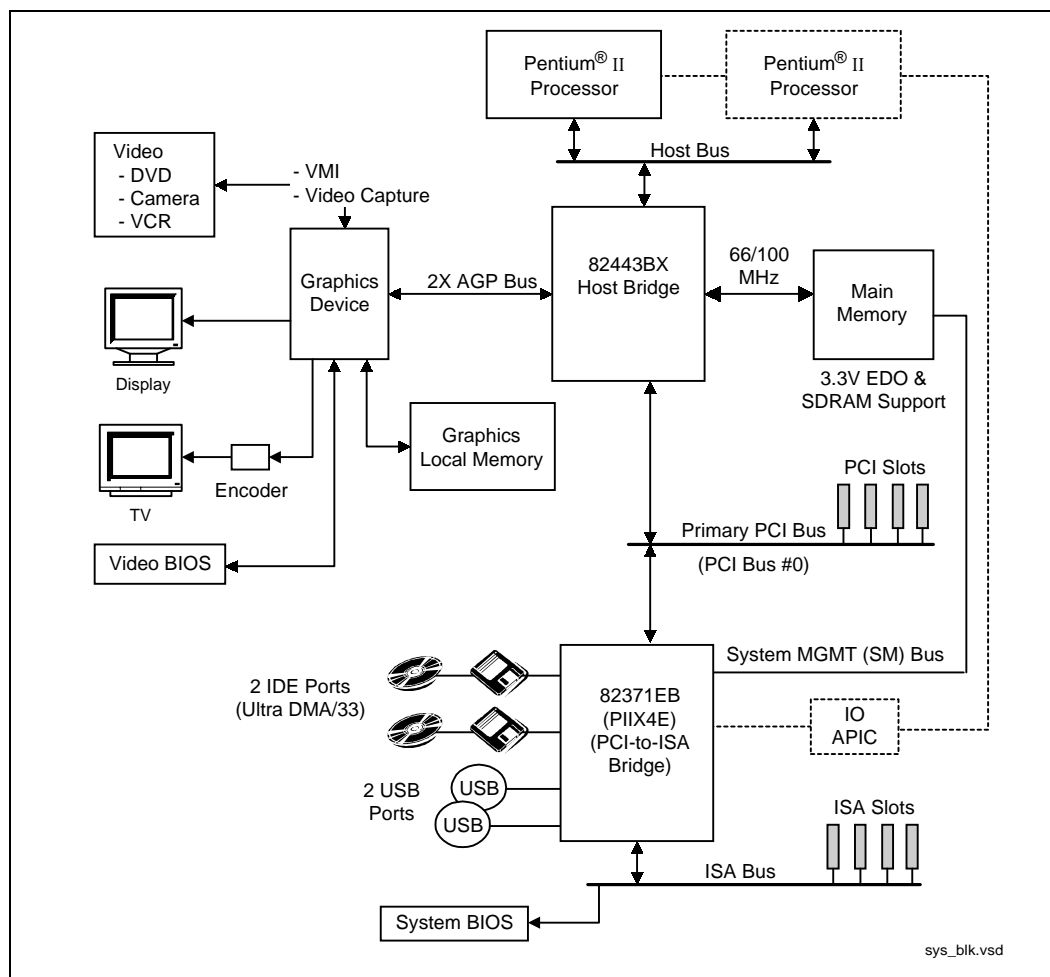

Host Interface

The Pentium II processor supports a second level cache via a back-side bus (BSB) interface. All control for the L2 cache is handled by the processor. The 82443BX provides bus control signals and address paths for transfers between the processors front-side bus (host bus), PCI bus, AGP and main memory. The 82443BX supports a 4-deep in-order queue (i.e., supports pipelining of up to 4 outstanding transaction requests on the host bus). Due to the system concurrency requirements, along with support for pipelining of address requests from the host bus, the 82443BX supports request queuing for all three interfaces (Host, AGP and PCI).

Host-initiated I/O cycles are decoded to PCI, AGP or PCI configuration space. Host-initiated memory cycles are decoded to PCI, AGP (prefetchable or non-prefetchable memory space) or DRAM (including AGP aperture memory). For memory cycles (host, PCI or AGP initiated) that target the AGP aperture space in DRAM, the 82443BX translates the address using the AGP address translation table. Other host cycles forwarded to AGP are defined by the AGP address map.

PCI and AGP initiated cycles that target the AGP graphics aperture are also translated using the AGP aperture translation table. AGP-initiated cycles that target the AGP graphics aperture mapped in main memory do not require a snoop cycle on the host bus, since the coherency of data for that particular memory range will be maintained by the software.

DRAM Interface

The 82443BX integrates a DRAM controller that supports a 64-bit main memory interface. The DRAM controller supports the following features:

- *DRAM type:* Extended Data Out (EDO) (mobile only) or Synchronous (SDRAM) DRAM controller optimized for dual/quad-bank SDRAM organization on a row by row basis
- *Memory Size:* 8 MB to 512 MB (1GB with Registered DIMMs) with eight memory rows
- *Addressing Type:* Symmetrical and Asymmetrical addressing
- *Memory Modules supported:* Single and double density 3.3V DIMMs
- *DRAM device technology:* 16 Mbit and 64 Mbit
- *DRAM Speeds:* 60 ns for EDO and 100/66 MHz for synchronous memory (SDRAM).

The Intel® 440BX AGPset also provides DIMM plug-and-play support via Serial Presence Detect (SPD) mechanism using the SMBus interface. The 82443BX provides optional data integrity features including ECC in the memory array. During reads from DRAM, the 82443BX provides error checking and correction of the data. The 82443BX supports multiple-bit error detection and single-bit error correction when ECC mode is enabled and single/multi-bit error detection when correction is disabled. During writes to the DRAM, the 82443BX generates ECC for the data on a QWord basis. Partial QWord writes require a read-modify-write cycle when ECC is enabled.

AGP Interface

The 82443BX AGP implementation is compatible with the following:

- The Accelerated Graphics Port Specification, Rev 1.0
- Accelerated Graphics Port Memory Performance Specification, Rev 1.0 (4/12/96)

The 82443BX supports only a synchronous AGP interface coupling to the 82443BX core frequency. The AGP interface can reach a theoretical ~500 MByte/sec transfer rate (i.e., using 133 MHz AGP compliant devices).

PCI Interface

The 82443BX PCI interface is 3.3V (5V tolerant), 33 MHz Rev. 2.1 compliant and supports up to five external PCI bus masters in addition to the I/O bridge (PIIX4/PIIX4E). The PCI-to-DRAM interface can reach over 100 MByte/sec transfer rate for streaming reads and over 120 MBytes/sec for streaming writes.

System Clocking

The 82443BX operates the host interface at 66 or 100 MHz, the SDRAM/core at 66 or 100 MHz, PCI at 33 MHz and AGP at 66/133 MHz.

I/O APIC

I/O APIC is used to support dual processors as well as enhanced interrupt processing in the single processor environment. The 82443BX supports an external status output signal that can be used to control synchronization of interrupts in configurations that use PIIX4E with stand-alone I/O APIC component.

Signal Description

2

This chapter provides a detailed description of 443BX signals. The signals are arranged in functional groups according to their associated interface.

The “#” symbol at the end of a signal name indicates that the active, or asserted state occurs when the signal is at a low voltage level. When “#” is not present after the signal name the signal is asserted when at the high voltage level.

The following notations are used to describe the signal type:

- I** Input pin
- O** Output pin
- OD** Open Drain Output pin. This pin requires a pullup to the VCC of the processor core
- I/OD** Input / Open Drain Output pin. This pin requires a pullup to the VCC of the processor core
- I/O** Bi-directional Input/Output pin

The signal description also includes the type of buffer used for the particular signal:

- GTL+** Open Drain GTL+ interface signal. Refer to the GTL+ I/O Specification for complete details
- PCI** PCI bus interface signals. These signals are compliant with the PCI 3.3V and 5.0V Signaling Environment DC and AC Specifications
- AGP** AGP interface signals. These signals are compatible with AGP 3.3V Signaling Environment DC and AC Specifications
- CMOS** The CMOS buffers are Low Voltage TTL compatible signals. These are 3.3V only.

2.1 Host Interface Signals

Table 2-1. Host Interface Signals (Sheet 1 of 2)

Name	Type	Description
CPURST#	O GTL+	CPU Reset. The CPURST# pin is an output from the 82443BX. The 82443BX generates this signal based on the PCIRST# input (from PII4E) and also the SUSTAT# pin in mobile mode. The CPURST# allows the CPUs to begin execution in a known state.
A[31:3]#	I/O GTL+	Address Bus: A[31:3]# connect to the CPU address bus. During CPU cycles, the A[31:3]# are inputs.
HD[63:0]#	I/O GTL+	Host Data: These signals are connected to the CPU data bus. Note that the data signals are inverted on the CPU bus.

Table 2-1. Host Interface Signals (Sheet 2 of 2)

Name	Type	Description																		
ADS#	I/O GTL+	Address Strobe: The CPU bus owner asserts ADS# to indicate the first of two cycles of a request phase.																		
BNR#	I/O GTL+	Block Next Request: Used to block the current request bus owner from issuing a new request. This signal is used to dynamically control the CPU bus pipeline depth.																		
BPRI#	0 GTL+	Priority Agent Bus Request: The 82443BX is the only Priority Agent on the CPU bus. It asserts this signal to obtain the ownership of the address bus. This signal has priority over symmetric bus requests and will cause the current symmetric owner to stop issuing new transactions unless the HLOCK# signal was asserted.																		
BREQ0#	0 GTL+	Symmetric Agent Bus Request: Asserted by the 82443BX when CPURST# is asserted to configure the symmetric bus agents. BREQ0# is negated 2 host clocks after CPURST# is negated.																		
DBSY#	I/O GTL+	Data Bus Busy: Used by the data bus owner to hold the data bus for transfers requiring more than one cycle.																		
DEFER#	0 GTL+	Defer: The 82443BX generates a deferred response as defined by the rules of the 82443BX's dynamic defer policy. The 82443BX also uses the DEFER# signal to indicate a CPU retry response.																		
DRDY#	I/O GTL+	Data Ready: Asserted for each cycle that data is transferred.																		
HIT#	I/O GTL+	Hit: Indicates that a caching agent holds an unmodified version of the requested line. Also driven in conjunction with HITM# by the target to extend the snoop window.																		
HITM#	I/O GTL+	Hit Modified: Indicates that a caching agent holds a modified version of the requested line and that this agent assumes responsibility for providing the line. Also driven in conjunction with HIT# to extend the snoop window.																		
HLOCK#	1 GTL+	Host Lock: All CPU bus cycles sampled with the assertion of HLOCK# and ADS#, until the negation of HLOCK# must be atomic, i.e. no PCI or AGP snoopable access to DRAM is allowed when HLOCK# is asserted by the CPU.																		
HREQ[4:0]#	I/O GTL+	Request Command: Asserted during both clocks of request phase. In the first clock, the signals define the transaction type to a level of detail that is sufficient to begin a snoop request. In the second clock, the signals carry additional information to define the complete transaction type. The transactions supported by the 82443BX Host Bridge are defined in the Host Interface section of this document.																		
HTRDY#	I/O GTL+	Host Target Ready: Indicates that the target of the CPU transaction is able to enter the data transfer phase.																		
RS[2:0]#	I/O GTL+	Response Signals: Indicates type of response according to the following the table: <table border="1"> <thead> <tr> <th>RS[2:0]</th> <th>Response type</th> </tr> </thead> <tbody> <tr> <td>000</td> <td>Idle state</td> </tr> <tr> <td>001</td> <td>Retry response</td> </tr> <tr> <td>010</td> <td>Deferred response</td> </tr> <tr> <td>011</td> <td>Reserved (not driven by 82443BX)</td> </tr> <tr> <td>100</td> <td>Hard Failure (not driven by 82443BX)</td> </tr> <tr> <td>101</td> <td>No data response</td> </tr> <tr> <td>110</td> <td>Implicit Writeback</td> </tr> <tr> <td>111</td> <td>Normal data response</td> </tr> </tbody> </table>	RS[2:0]	Response type	000	Idle state	001	Retry response	010	Deferred response	011	Reserved (not driven by 82443BX)	100	Hard Failure (not driven by 82443BX)	101	No data response	110	Implicit Writeback	111	Normal data response
RS[2:0]	Response type																			
000	Idle state																			
001	Retry response																			
010	Deferred response																			
011	Reserved (not driven by 82443BX)																			
100	Hard Failure (not driven by 82443BX)																			
101	No data response																			
110	Implicit Writeback																			
111	Normal data response																			

NOTE:

1. All of the signals in the host interface are described in the CPU External Bus Specification. The preceding table highlights 82443BX specific uses of these signals.

Table 2-2 lists the CPU bus interface signals which are NOT supported by the Intel® 440BX AGPset.

Table 2-2. Host Signals Not supported by the 82443BX

Signal	Function	Not Supported By 82443BX
A[35:32]#	Address	Extended addressing (over 4 GB)
AERR#	Address Parity Error	Parity protection on address bus
AP[1:0]#	Address Parity	Parity protection on address bus
BINIT#	Bus Initialization	Checking for bus protocol violation and protocol recovery mechanism
DEP[7:0]#	Data Bus ECC/Parity	Enhanced data bus integrity
IERR#	Internal Error	Direct internal error observation via IERR# pin
INIT#	Soft Reset	Implemented by PIIX4E, BIST supported by external logic.
BERR#	Bus Error	Unrecoverable error without a bus protocol violation
RP#	Request Parity	Parity protection on ADS# and PREQ[4:0]#
RSP#	Response Parity Signal	Parity protection on RS[2:0]#

2.2 DRAM Interface

Table 2-3. DRAM Interface Signals (Sheet 1 of 2)

Name	Type	Description
RASA[5:0]# /CSA[5:0]# RASB[5:0]# /CSB[5:0]#	O CMOS	Row Address Strobe (EDO): These signals are used to latch the row address on the MAxx lines into the DRAMs. Each signal is used to select one DRAM row. These signals drive the DRAM array directly without any external buffers. Chip Select (SDRAM): For the memory row configured with SDRAM these pins perform the function of selecting the particular SDRAM components during the active state. Note that there are 2 copies of RAS# per physical memory row to improve the loading.
CKE[3:2] /CSA[7:6]# CKE[5:4] /CSB[7:6]#	O CMOS	Clock Enable: In mobile mode, SDRAM Clock Enable is used to signal a self-refresh or power-down command to an SDRAM array when entering system suspend. CKE is also used to dynamically power down inactive SDRAM rows. This CKE function is not supported with Registered DIMMs. Chip Select (SDRAM): These pins perform the function of selecting the particular SDRAM components during the active state. Note that there are 2 copies of CS# per physical memory row to reduce the loading.
CASA[7:0]# /DQMA[7:0]	O CMOS	Column Address Strobe A-side (EDO): The CASA[7:0]# signals are used to latch the column address on the MA[13:0] lines into the DRAMs of the A half of the memory array. These are active low signals that drive the DRAM array directly without external buffering. Input/Output Data Mask A-side (SDRAM): These pins control A half of the memory array and act as synchronized output enables during read cycles and as a byte enables during write cycles.
CASB[1,5]# /DQMB[1,5]	O CMOS	Column Address Strobe B-side (EDO) / Input/Output Data Mask B-side (SDRAM): The same function as a corresponding signals for A side. These signals are used to reduce the loading in an ECC configuration

Table 2-3. DRAM Interface Signals (Sheet 2 of 2)

Name	Type	Description
GCKE/CKE1	○ CMOS	Global CKE (SDRAM): Global CKE is used in a 4 DIMM configuration requiring power down mode for the SDRAM. External logic must be used to implement this function. SDRAM Clock Enable (CKE1): In mobile mode, SDRAM Clock Enable is used to signal a self-refresh or power-down command to an SDRAM array when entering system suspend. CKE is also used to dynamically power down inactive SDRAM rows. The combination of SDRAMPWR (SDRAM register) and MMCONFIG (DRAMC register) determine the functioning of the CKE signals. Refer to the DRAMC register (Section 3.3.15, “DRAMC—DRAM Control Register (Device 0)” on page 3-19) for more details.
SRAS[B,A]#	○ CMOS	SDRAM Row Address Strobe (SDRAM): The SRAS[B,A]# signals are multiple copies of the same logical SRASx signal (for loading purposes) used to generate SDRAM command encoded on SRASx/SCASx/WE signals.
CKE0/FENA	○ CMOS	SDRAM Clock Enable 0 (CKE0). In mobile mode, CKE0 SDRAM Clock Enable is used to signal a self-refresh or power-down command to an SDRAM array when entering system suspend. CKE is also used to dynamically power down inactive SDRAM rows. FET Enable (FENA): In a 4 DIMM configuration. FENA is used to select the proper MD path through the FET switches (refer to Section 4.3, “DRAM Interface” on page 4-14 for more details).
SCAS[B,A]#	○ CMOS	SDRAM Column Address Strobe (SDRAM): The SCAS[B,A]# signals are multiple copies of the same logical SCASx signal (for loading purposes) used to generate SDRAM command encoded on SRASx/SCASx/WE signals.
MAA[13:0] MAB[12:11]# MAB[13,10] MAB[9:0]#	○ CMOS	Memory Address(EDO/SDRAM): MAA[13:0] and MAB[13:0]# are used to provide the multiplexed row and column address to DRAM. There are two sets of MA signals which drive a max. of 2 DIMMs each. MAA[12:11,9:0] are inverted copies of MAB[12:11,9:0]#. MAA[13,10] and MAB[13,10] are identical copies. Each MAA/MAB[13:0] line has a programmable buffer strength to optimize for different signal loading conditions.
WEA# WEB#	○ CMOS	Write Enable Signal (EDO/SDRAM): WE# is asserted during writes to DRAM. The WE# lines have a programmable buffer strength to optimize for different signal loading conditions.
MD [63:0]	I/O CMOS	Memory Data (EDO/SDRAM): These signals are used to interface to the DRAM data bus.
MECC[7:0]	I/O CMOS	Memory ECC Data (EDO/SDRAM): These signals carry Memory ECC data during access to DRAM.

2.3 PCI Interface (Primary)

Table 2-4. Primary PCI Interface Signals (Sheet 1 of 2)

Name	Type	Description																																
AD[31:0]	I/O PCI	PCI Address/Data: These signals are connected to the PCI address/data bus. Address is driven by the 82443BX with FRAME# assertion, data is driven or received in the following clocks. When the 82443BX acts as a target on the PCI Bus, the AD[31:0] signals are inputs and contain the address during the first clock of FRAME# assertion and input data (writes) or output data (reads) on subsequent clocks.																																
DEVSEL#	I/O PCI	Device Select: Device select, when asserted, indicates that a PCI target device has decoded its address as the target of the current access. The 82443BX asserts DEVSEL# based on the DRAM address range or AGP address range being accessed by a PCI initiator. As an input it indicates whether any device on the bus has been selected.																																
FRAME#	I/O PCI	Frame: FRAME# is an output when the 82443BX acts as an initiator on the PCI Bus. FRAME# is asserted by the 82443BX to indicate the beginning and duration of an access. The 82443BX asserts FRAME# to indicate a bus transaction is beginning. While FRAME# is asserted, data transfers continue. When FRAME# is negated, the transaction is in the final data phase. FRAME# is an input when the 82443BX acts as a PCI target. As a PCI target, the 82443BX latches the C/BE[3:0]# and the AD[31:0] signals on the first clock edge on which it samples FRAME# active.																																
IRDY#	I/O PCI	Initiator Ready: IRDY# is an output when 82443BX acts as a PCI initiator and an input when the 82443BX acts as a PCI target. The assertion of IRDY# indicates the current PCI Bus initiator's ability to complete the current data phase of the transaction.																																
C/BE[3:0]#	I/O PCI	<p>Command/Byte Enable: PCI Bus Command and Byte Enable signals are multiplexed on the same pins. During the address phase of a transaction, C/BE[3:0]# define the bus command. During the data phase C/BE[3:0]# are used as byte enables. The byte enables determine which byte lanes carry meaningful data. PCI Bus command encoding and types are listed below.</p> <p>C/BE[3:0]# Command Type</p> <table> <tbody> <tr><td>0000</td><td>Interrupt Acknowledge</td></tr> <tr><td>0001</td><td>Special Cycle</td></tr> <tr><td>0010</td><td>I/O Read</td></tr> <tr><td>0011</td><td>I/O Write</td></tr> <tr><td>0100</td><td>Reserved</td></tr> <tr><td>0101</td><td>Reserved</td></tr> <tr><td>0110</td><td>Memory Read</td></tr> <tr><td>0111</td><td>Memory Write</td></tr> <tr><td>1000</td><td>Reserved</td></tr> <tr><td>1001</td><td>Reserved</td></tr> <tr><td>1010</td><td>Configuration Read</td></tr> <tr><td>1011</td><td>Configuration Write</td></tr> <tr><td>1100</td><td>Memory Read Multiple</td></tr> <tr><td>1101</td><td>Reserved (Dual Address Cycle)</td></tr> <tr><td>1110</td><td>Memory Read Line</td></tr> <tr><td>1111</td><td>Memory Write and Invalidate</td></tr> </tbody> </table>	0000	Interrupt Acknowledge	0001	Special Cycle	0010	I/O Read	0011	I/O Write	0100	Reserved	0101	Reserved	0110	Memory Read	0111	Memory Write	1000	Reserved	1001	Reserved	1010	Configuration Read	1011	Configuration Write	1100	Memory Read Multiple	1101	Reserved (Dual Address Cycle)	1110	Memory Read Line	1111	Memory Write and Invalidate
0000	Interrupt Acknowledge																																	
0001	Special Cycle																																	
0010	I/O Read																																	
0011	I/O Write																																	
0100	Reserved																																	
0101	Reserved																																	
0110	Memory Read																																	
0111	Memory Write																																	
1000	Reserved																																	
1001	Reserved																																	
1010	Configuration Read																																	
1011	Configuration Write																																	
1100	Memory Read Multiple																																	
1101	Reserved (Dual Address Cycle)																																	
1110	Memory Read Line																																	
1111	Memory Write and Invalidate																																	
PAR	I/O PCI	Parity: PAR is driven by the 82443BX when it acts as a PCI initiator during address and data phases for a write cycle, and during the address phase for a read cycle. PAR is driven by the 82443BX when it acts as a PCI target during each data phase of a PCI memory read cycle. Even parity is generated across AD[31:0] and C/BE[3:0]#.																																
PLOCK#	I/O PCI	Lock: PLOCK# indicates an exclusive bus operation and may require multiple transactions to complete. When PLOCK# is asserted, non-exclusive transactions may proceed. The 82443BX supports lock for CPU initiated cycles only. PCI initiated locked cycles are not supported.																																
TRDY#	I/O PCI	Target Ready: TRDY# is an input when the 82443BX acts as a PCI initiator and an output when the 82443BX acts as a PCI target. The assertion of TRDY# indicates the target agent's ability to complete the current data phase of the transaction.																																

Table 2-4. Primary PCI Interface Signals (Sheet 2 of 2)

Name	Type	Description
SERR#	I/O PCI	<p>System Error: The 82443BX asserts this signal to indicate an error condition. The SERR# assertion by the 82443BX is enabled globally via SERRE bit of the PCICMD register. SERR# is asserted under the following conditions:</p> <p>In an ECC configuration, the 82443BX asserts SERR#, for single bit (correctable) ECC errors or multiple bit (non-correctable) ECC errors if SERR# signaling is enabled via the ERRCMD control register. Any ECC errors received during initialization should be ignored.</p> <ul style="list-style-type: none"> The 82443BX asserts SERR# for one clock when it detects a target abort during 82443BX initiated PCI cycle. The 82443BX can also assert SERR# when a PCI parity error occurs during the address or data phase. The 82443BX can assert SERR# when it detects a PCI address or data parity error on AGP. The 82443BX can assert SERR# upon detection of access to an invalid entry in the Graphics Aperture Translation Table. The 82443BX can assert SERR# upon detecting an invalid AGP master access outside of AGP aperture and outside of main DRAM range (i.e. in the 640k - 1M range or above TOM). The 82443BX can assert SERR# upon detecting an invalid AGP master access outside of AGP aperture. The 82443BX asserts SERR# for one clock when it detects a target abort during 82443BX initiated AGP cycle.
STOP#	I/O PCI	<p>Stop: STOP# is an input when the 82443BX acts as a PCI initiator and an output when the 82443BX acts as a PCI target. STOP# is used for disconnect, retry, and abort sequences on the PCI Bus.</p>

NOTE:

- All PCI interface signals conform to the PCI Rev 2.1 specification.

2.4 Primary PCI Sideband Interface

Table 2-5. Primary PCI Sideband Interface Signals

Name	Type	Description
PHOLD#	I PCI	<p>PCI Hold: This signal comes from the PIIX4E. It is the PIIX4E request for PCI bus ownership. The 82443BX will flush and disable the CPU-to-PCI write buffers before granting the PIIX4E the PCI bus via PHLDA#. This prevents bus deadlock between PCI and ISA.</p>
PHLDA#	O PCI	<p>PCI Hold Acknowledge: This signal is driven by the 82443BX to grant PCI bus ownership to the PIIX4E after CPU-PCI post buffers have been flushed and disabled.</p>
WSC#	O CMOS	<p>Write Snoop Complete. This signal is asserted active to indicate that all that the snoop activity on the CPU bus on the behalf of the last PCI-DRAM write transaction is complete and that is safe to send the APIC interrupt message.</p>
PREQ[4:0]#	I PCI	<p>PCI Bus Request: PREQ[4:0]# are the PCI bus request signals used as inputs by the internal PCI arbiter.</p>
PGNT[4:0]#	O PCI	<p>PCI Grant: PGNT[4:0]# are the PCI bus grant output signals generated by the internal PCI arbiter.</p>

2.5 AGP Interface Signals

There are 17 new signals added to the normal PCI group of signals that together constitute the AGP interface. The sections below describe their operation and use, and are organized in five groups:

- AGP Addressing Signals
- AGP Flow Control Signals
- AGP Status Signals
- AGP Clocking Signals - Strobes
- PCI Signals

Table 2-6. AGP Interface Signals (Sheet 1 of 2)

Name	Type	Description
AGP Sideband Addressing Signals¹		
PIPE#	I AGP	Pipelined Read: This signal is asserted by the current master to indicate a full width address is to be queued by the target. The master queues one request each rising clock edge while PIPE# is asserted. When PIPE# is deasserted no new requests are queued across the AD bus. PIPE# is a sustained tri-state signal from <i>masters (graphics controller)</i> and is an input to the 82443BX. Note that initial AGP designs may not use PIPE#.
SBA[7:0]	I AGP	Sideband Address: This bus provides an additional bus to pass address and command to the 82443BX from the AGP master. Note that, when sideband addressing is disabled, these signals are isolated (no external/internal pull-ups are required).
AGP Flow Control Signals		
RBF#	I AGP	Read Buffer Full. This signal indicates if the master is ready to accept previously requested low priority read data. When RBF# is asserted the 82443BX is not allowed to return low priority read data to the AGP master on the first block. RBF# is only sampled at the beginning of a cycle. If the AGP master is always ready to accept return read data then it is not required to implement this signal.
AGP Status Signals		
ST[2:0]	O AGP	Status Bus: This bus provides information from the arbiter to a AGP Master on what it may do. ST[2:0] only have meaning to the master when its GGNT# is asserted. When GGNT# is deasserted these signals have no meaning and must be ignored. 000 Indicates that previously requested low priority read data is being returned to the master. 001 Indicates that previously requested high priority read data is being returned to the master. 010 Indicates that the master is to provide low priority write data for a previously queued write command. 011 Indicates that the master is to provide high priority write data for a previously queued write command. 100 Reserved 101 Reserved 110 Reserved 111 Indicates that the master has been given permission to start a bus transaction. The master may queue AGP requests by asserting PIPE# or start a PCI transaction by asserting FRAME#. ST[2:0] are always an output from the 82443BX and an input to the master.

Table 2-6. AGP Interface Signals (Sheet 2 of 2)

Name	Type	Description
AGP Clocking Signals - Strobes		
ADSTB_A	I/O AGP	AD Bus Strobe A: This signal provides timing for double clocked data on the AD bus. The agent that is providing data drives this signal. This signal requires an 8.2K ohm external pull-up resistor.
ADSTB_B	I/O AGP	AD Bus Strobe B: This signal is an additional copy of the AD_STBA signal. This signal requires an 8.2K ohm external pull-up resistor.
SBSTB	I AGP	Sideband Strobe: This signal provides timing for a side-band bus. This signal requires an 8.2K ohm external pull-up resistor.
AGP FRAME# Protocol Signals (similar to PCI)²		
GFRAME#	I/O AGP	Graphics Frame: Same as PCI. Not used by AGP. GFRAME# remains deasserted by its own pull up resistor.
GIRDY#	I/O AGP	Graphics Initiator Ready: New meaning. GIRDY# indicates the AGP compliant master is ready to provide <i>all</i> write data for the current transaction. Once IRDY# is asserted for a write operation, the master is not allowed to insert wait states. The assertion of IRDY# for reads indicates that the master is ready to transfer to a subsequent block (32 bytes) of read data. The master is <i>never</i> allowed to insert wait states during the initial data transfer (32 bytes) of a read transaction. However, it may insert wait states after each 32 byte block is transferred. <i>(There is no GFRAME# -- GIRDY# relationship for AGP transactions.)</i>
GTRDY#	I/O AGP	Graphics Target Ready: New meaning. GTRDY# indicates the AGP compliant target is ready to provide read data for the entire transaction (when the transfer size is less than or equal to 32 bytes) or is ready to transfer the initial or subsequent block (32 bytes) of data when the transfer size is greater than 32 bytes. The target is allowed to insert wait states after each block (32 bytes) is transferred on both read and write transactions.
GSTOP#	I/O AGP	Graphics Stop: Same as PCI. Not used by AGP.
GDEVSEL#	I/O AGP	Graphics Device Select: Same as PCI. Not used by AGP.
GREQ#	I AGP	Graphics Request: Same as PCI. (Used to request access to the bus to initiate a PCI or AGP request.)
GGNT#	O AGP	Graphics Grant: Same meaning as PCI but additional information is provided on ST[2:0]. The additional information indicates that the selected master is the recipient of previously requested read data (high or normal priority), it is to provide write data (high or normal priority), for a previously queued write command or has been given permission to start a bus transaction (AGP or PCI).
GAD[31:0]	I/O AGP	Graphics Address/Data: Same as PCI.
GC/BE[3:0]#	I/O AGP	Graphics Command/Byte Enables: Slightly different meaning. Provides command information (different commands than PCI) when requests are being queued when using PIPE#. Provide valid byte information during AGP write transactions and are not used during the return of read data.
GPAR	I/O AGP	Graphics Parity: Same as PCI. Not used on AGP transactions, but used during PCI transactions as defined by the PCI specification.

NOTE:

- AGP Sideband Addressing Signals.** The above table contains two mechanisms to queue requests by the AGP master. Note that the master can only use one mechanism. When PIPE# is used to queue addresses the master is not allowed to queue addresses using the SBA bus. For example, during configuration time, if the master indicates that it can use either mechanism, the configuration software will indicate which mechanism the master will use. Once this choice has been made, the master will continue to use the mechanism selected until the master is reset (and reprogrammed) to use the other mode. This change of modes is not a dynamic mechanism but rather a static decision when the device is first being configured after reset.

2. PCI signals are redefined when used in AGP transactions carried using AGP protocol extension. For transactions on the AGP interface carried using PCI protocol these signals completely preserve PCI semantics. The exact role of all PCI signals during AGP transactions is in Table 2-6.
3. The LOCK# signal is not supported on the AGP interface (even for PCI operations).
4. PCI signals described in Table 2-4 behave according to PCI 2.1 specifications when used to perform PCI transactions on the AGP Interface.

2.6 Clocks, Reset, and Miscellaneous

Table 2-7. Clocks, Reset, and Miscellaneous

Name	Type	Description
HCLKIN	I CMOS	Host Clock In: This pin receives a buffered host clock. This clock is used by all of the 82443BX logic that is in the Host clock domain. When SUSTAT# is active, there is an internal 100K ohm pull down on this signal.
PCLKIN	I CMOS	PCI Clock In: This is a buffered PCI clock reference that is synchronously derived by an external clock synthesizer component from the host clock. This clock is used by all of the 82443BX logic that is in the PCI clock domain. When SUSTAT# is active, there is an internal 100K ohm pull down on this signal.
DCLKO	O CMOS	SDRAM Clock Out: 66 or 100 MHz SDRAM clock reference. It feeds an external buffer clock device that produces multiple copies for the DIMMs.
DCLKWR	I CMOS	SDRAM Write Clock: Feedback reference from the external SDRAM clock buffer. This clock is used by the 82443BX when writing data to the SDRAM array. Note: See the Design Guide for routing constraints.
PCIRST#	I CMOS	PCI Reset: When asserted, this signal will reset the 82443BX logic. All PCI output and bi-directional signals will also tri-state compliant to PCI Rev 2.0 and 2.1 specifications. When SUSTAT# is active, there is an internal 100K ohm pull down on this signal.
GCLKIN	I CMOS	AGP Clock In: The GCLKIN input is a feedback reference from the GCLKOUT signal.
GCLKO	O CMOS	AGP Clock Out: The frequency is 66 MHz. The GCLKOUT output is used to feed both the reference input pin on the 82443BX and the AGP compliant device.
CRESET#	O CMOS	Delayed CPU Reset: CRESET# is a delayed copy of CPURST#. This signal is used to control the multiplexer for the CPU strap signals. CRESET# is delayed from CPURST# by two host clocks. Note: This pin requires an external pull-up resistor. If not used, no pull up is required.
TESTIN#	I CMOS	Test Input: This pin is used for manufacturing, and board level test purposes. Note: This pin has an internal 50K ohm pull-up.

Table 2-8. Power Management Interface

Name	Type	Description
CLKRUN#	I/OD CMOS	Primary PCI Clock Run: The 82443BX requests the central resource (PIIX4E) to start or maintain the PCI clock by the assertion of CLKRUN#. The 82443BX tristates CLKRUN# upon deassertion of PCIRST# (since CLK is running upon deassertion of reset). If connected to PIIX4E an external 2.7K Ohm pull-up is required for Desktop, Mobile requires (8.2k–10K) pull-up. Otherwise, a 100 Ohm pull down is required.
SUSTAT#	I CMOS	Suspend Status (from PIIX): SUSTAT# signals the system suspend state transition from the PIIX4E. It is used to isolate the suspend voltage well and enter/exit DRAM self-refresh mode. During POS/STR SUSTAT# is active.
BXPWROK	I CMOS	BX Power OK: BXPWROK input must be connected to the PWROK signal that indicates valid power is applied to the 82443BX.

Table 2-9. Reference Pins

Name	Description
GTLREF[B:A]	GTL Buffer voltage reference input
VTT[B:A]	GTL Threshold voltage for early clamps
VCC	Power pin @ 3.3V
VSS	Ground
REF5V	PCI 5V reference voltage (for 5V tolerant buffers)
AGPREF	External Input Reference

2.7 Power-Up/Reset Strap Options

Table 2-10 is the list of all power-up options that are loaded into the 82443BX during cold reset. The 82443BX is required to float all the signals connected to straps during cold reset and keep them floated for a minimum of 4 host clocks after the end of cold reset sequence. Cold reset sequence is performed when the 82443BX power is applied.

Note: All signals used to select power-up strap options are connected to either internal pull-down or pull-up resistors of minimum 50K ohms (maximum is 150K). That selects a default mode on the signal during reset. To enable different modes, external pull ups or pull downs (the opposite of the internal resistor) of approximately 10K ohm can be connected to particular signals. These pull up or pull down resistors should be connected to the 3.3V power supply.

During normal operation of the 82443BX, including while it is in suspend mode, the paths from GND or Vcc to internal strapping resistors are disabled to effectively disable the resistors. In these cases, the MAB# lines are driven by the 82443BX to a valid voltage levels.

Note: Note that when resuming from suspend, even while PCIRST# is active, the MAB# lines remain driven by the 82443BX and the strapping latches maintain the value stored during the cold reset.

This first column in Table 2-10 lists the signal that is sampled to obtain the strapping option. The second column shows which register the strapping option is loaded into. The third column is a description of what functionality the strapping selects.

The GTL+ signals are connected to the VTT through the normal pull-ups. CPU bus straps controlled by the 82443BX (e.g. A7# and A15#), are driven active at least six clocks prior to the active-to-inactive edge of CPURST# and driven inactive four clocks after the active-to-inactive edge of the CPURST#.

Table 2-10. Strapping Options

Signal	Register Name[bit]	Description
MAB13#		Reserved.
MAB12#	NBXCFG[13]	Host Frequency Select: If MAB#12 is strapped to 0, the host bus frequency is 60/66 MHz. If MAB#12 is strapped to 1, the host bus frequency is 100 MHz. An internal pull-down is used to provide the default setting of 66 MHz.
MAB11#	NBXCFG[2]	In-Order Queue Depth Enable. If MAB11# is strapped to 0 during the rising edge of PCIRST#, then the 82442BX will drive A7# low during the CPURST# deassertion. This forces the CPU bus to be configured for non-pipelined operation. If MAB11 is strapped to 1 (default), then the 82443BX does not drive the A7# low during reset, and A7# is sampled in default non-driven state (i.e. pulled-up as far as GTL+ termination is concerned) then the maximum allowable queue depth by the CPU bus protocol is selected (i.e., 8). Note that internal pull-up is used to provide pipelined bus mode as a default.
MAB10	PMCR[3]	Quick Start Select. The value on this pin at reset determines which stop clock mode is used. MAB10 = 0 (default) for normal stop clock mode. If MAB10 = 1 during the rising edge of PCIRST#, then the 82443BX will drive A15# low during CPURST# deassertion. This will configure the CPU for Quick Start mode of operation. Note that internal pull-down is used to provide normal stop clock mode as a default.
MAB9#	PMCR[1]	AGP Disable: When strapped to a 1, the AGP interface is disabled, all AGP signals are tri-stated and isolated. When strapped to a 0 (default), the AGP interface is enabled. When MMCONFIG is strapped active, we require that AGP_DISABLE is also strapped active. When MMCONFIG is strapped inactive, AGP_DISABLE can be strapped active or inactive but IDSEL_REDIRECT (bit 16 in NBXCFG register) must never be activated. This signal has an internal pull-down resistor.
MAB8#		Reserved.
MAB7#	DRAMC[5]	Memory Module Configuration, MMCONFIG: When strapped to a 1, the 82443BX configures its DRAM interface in a 430-TX compatible manner. These unused inputs are isolated while unused outputs are tri-stated: RASB[5:0]#/CSB[5:0]#, CKE[3:2]/CSA[7:6]#, CKE[5:4]/CSB[7:6]#, CASB[5,1]#/DQMB[5,1], GCKE/CKE1, MAA[13:0], DCLKO. When strapped to a 0 (default), the 82443BX DRAM signal are used normally. IDSEL_REDIRECT (bit 16 in NBXCFG register) is programmed by BIOS, before it begins with device enumeration process. The combination of SDRAMC (SDRAMC register) and MMCONFIG (DRAMC register) determine the functioning of the CKE signals. Refer to the DRAMC register for more details. Note that internal pull-down is used to set the DRAM interface to a normal configuration, as a default.
MAB6#	none	Host Bus Buffer Mode Select: When strapped 0, the desktop GTL+ 66 MHz or 100 MHz host bus buffers are used (default). When strapped '1', the mobile Low Power GTL+ 66 MHz host bus buffers are selected. Note that internal pull-down is used to set the host bus buffers to a desktop configuration as a default. External pull-up therefore is needed for mobile systems, only.
A[15]#	none	Quick Start Select. The value on A15# sampled at the rising edge of CPURST# will reflect if the quick start/stop clock mode is enabled in the processors.
A7#	none	In-order Queue Depth Status. The value on A[7]# sampled at the rising edge of CPURST# reflects if the IOQD is set to 1 or maximum allowable by the CPU bus.

NOTE:

1. Proper strapping must be used to define logical values for these signals. Default value "0", or "1" provided by the internal pull-up or pull-down resistor can be overridden by the external pull-up, or pull-down resistor.

Register Description

3

The 82443BX contains two sets of software accessible registers, accessed via the Host CPU I/O address space:

1. Control registers that are I/O mapped into the CPU I/O space. These registers control access to PCI and AGP configuration space.
2. Internal configuration registers residing within the 82443BX, partitioned into two logical device register sets (“logical” since they reside within a single physical device). The first register set is dedicated to Host-to-PCI Bridge functionality. This set (device 0) controls PCI interface operations, DRAM configuration, and other chip-set operating parameters and optional features. The second register set (device 1) is dedicated to Host-to-AGP Bridge functions (controls AGP interface configurations and operating parameters).

The following nomenclature is used for register access attributes.

RO	Read Only. If a register is read only, writes to this register have no effect.
R/W	Read/Write. A register with this attribute can be read and written
R/WC	Read/Write Clear. A register bit with this attribute can be read and written. However, a write of a 1 clears (sets to 0) the corresponding bit and a write of a 0 has no effect.
R/WO	Read/Write Once. A register bit with this attribute can be written to only once after power up. After the first write, the bit becomes read only.
R/WL	Read/Write/Lock. This register includes a lock bit. Once the lock bit has been set to 1, the register becomes read only.

The 82443BX supports PCI configuration space access using the mechanism denoted as Configuration Mechanism #1 in the PCI specification.

The 82443BX internal registers (both I/O Mapped and Configuration registers) are accessible by the Host CPU. The registers can be accessed as Byte, Word (16-bit), or DWord (32-bit) quantities, with the exception of CONFADD which can only be accessed as a Dword. All multi-byte numeric fields use "little-endian" ordering (i.e., lower addresses contain the least significant parts of the field).

Some of the 82443BX registers described in this section contain reserved bits. These bits are labeled "Reserved". Software must deal correctly with fields that are reserved. On reads, software must use appropriate masks to extract the defined bits and not rely on reserved bits being any particular value. On writes, software must ensure that the values of reserved bit positions are preserved. That is, the values of reserved bit positions must first be read, merged with the new values for other bit positions and then written back.

Note: Software does not need to perform read, merge, write operation for the configuration address register.

In addition to reserved bits within a register, the 82443BX contains address locations in the configuration space of the Host-to-PCI Bridge entity that are marked either "Reserved" or "Intel Reserved". The 82443BX responds to accesses to "Reserved" address locations by completing the host cycle. When a "Reserved" register location is read, a zero value is returned. ("Reserved" registers can be 8-, 16-, or 32-bit in size). Writes to "Reserved" registers have no effect on the

82443BX. Registers that are marked as “Intel Reserved” must not be modified by system software. Writes to “Intel Reserved” registers may cause system failure. Reads to “Intel Reserved” registers may return a non-zero value. Software should not write to reserved configuration locations in the device-specific region (above address offset 3Fh)

Upon reset, the 82443BX sets its internal configuration registers to predetermined default states. However, there are a few exceptions to this rule.

1. When a reset occurs during the POS/STR state, several configuration bits are not reset to their default state. These bits are noted in the following register description.
2. Some register values at reset are determined by external strapping options.

The default state represents the minimum functionality feature set required to successfully bring up the system. Hence, it does not represent the optimal system configuration. It is the responsibility of the system initialization software (usually BIOS) to properly determine the DRAM configurations, operating parameters and optional system features that are applicable, and to program the 82443BX registers accordingly.

3.1 I/O Mapped Registers

The 82443BX contains three registers that reside in the CPU I/O address space – the Configuration Address (CONFADD) Register, the Configuration Data (CONFDATA) Register, and the Power Management Control Register. The Configuration Address Register enables/disables the configuration space and determines what portion of configuration space is visible through the Configuration Data window.

3.1.1 CONFADD—Configuration Address Register

I/O Address:	0CF8h Accessed as a Dword
Default Value:	00000000h
Access:	Read/Write
Size:	32 bits

CONFADD is a 32 bit register accessed only when referenced as a Dword. A Byte or Word reference will "pass through" the Configuration Address Register onto the PCI bus as an I/O cycle. The CONFADD register contains the Bus Number, Device Number, Function Number, and Register Number for which a subsequent configuration access is intended.

Bit	Descriptions
31	Configuration Enable (CFGE). When this bit is set to 1 accesses to PCI configuration space are enabled. If this bit is reset to 0 accesses to PCI configuration space are disabled.
30:24	Reserved.
23:16	Bus Number. When the Bus Number is programmed to 00h the target of the Configuration Cycle is either the 82443BX or the PCI Bus that is directly connected to the 82443BX, depending on the Device Number field. A type 0 Configuration Cycle is generated on PCI if the Bus Number is programmed to 00h and the 82443BX is not the target. If the Bus Number is non-zero a type 1 configuration cycle is generated on PCI or AGP with the Bus Number mapped to AD[23:16] during the address phase.
15:11	Device Number. This field selects one agent on the PCI bus selected by the Bus Number. During a Type 1 Configuration cycle this field is mapped to AD[15:11]. During a Type 0 Configuration Cycle this field is decoded and one bit among AD[31:11] is driven to a 1. The 82443BX is always Device Number 0 for the Host-to-PCI bridge entity and Device Number 1 for the Host- AGP entity. Therefore, the 82443BX internally references the AD11 and AD12 pins as corresponding IDSELS for the respective devices during PCI configuration cycles. NOTE: The AD11 and AD12 must not be connected to any other PCI bus device as IDSEL signals.
10:8	Function Number. This field is mapped to AD[10:8] during PCIX configuration cycles. This allows the configuration registers of a particular function in a multi-function device to be accessed. The 82443BX only responds to configuration cycles with a function number of 000b; all other function number values attempting access to the 82443BX (Device Number = 0 and 1, Bus Number = 0) will generate a master abort.
7:2	Register Number. This field selects one register within a particular Bus, Device, and Function as specified by the other fields in the Configuration Address Register. This field is mapped to AD[7:2] during PCI configuration cycles.
1:0	Reserved.

3.1.2 CONFDATA—Configuration Data Register

I/O Address: 0CFCh
 Default Value: 00000000h
 Access: Read/Write
 Size: 32 bits

CONFDATA is a 32 bit read/write window into configuration space. The portion of configuration space that is referenced by CONFDATA is determined by the contents of CONFADD.

Bit	Descriptions
31:0	Configuration Data Window (CDW). If bit 31 of CONFADD is 1 any I/O reference that falls in the CONFDATA I/O space will be mapped to configuration space using the contents of CONFADD.

3.1.3 PM2_CTL—ACPI Power Control 2 Control Register

I/O Address: 0022h
 Default Value: 00h
 Access: Read/Write
 Size: 8 bits

This register is used to disable both the PCI and AGP arbiters in the 82443BX to prevent any external bus masters from acquiring the PCI or AGP bus. Any currently running PCI cycles will terminate properly.

Accesses to this register are controlled by the Power Management Control Register (Offset 7Ah). When bit 6 of the PMCR is set to '1', the ACPI Register at I/O location 0022h is enabled. When bit 6 is set to '0', I/O accesses to location 0022h are forwarded to PCI or AGP (if within programmable IO range).

Bit	Description
7:1	Reserved
0	<p>Primary PCI and AGP Arbiter Request Disable (ARB_DIS). When this bit is set to 1, the 82443BX will not respond to any PCI REQ# signals, AGP requests, or PHOLD# from PIIX4E going active until this bit is set back to 0. Only External AGP and PCI requests are masked from the arbiters. If the PIIX is in passive release mode, masking will not occur until an active release is seen via PHLDA# assertion. This prevents possible deadlock.</p> <p>ARB_DIS has no effect on AGP side band signals or AGP data transfer requests.</p>

3.2 PCI Configuration Space Access

The 82443BX implementation manifests two PCI devices within a single physical component body:

- Device 0 = Host-to-PCI Bridge = PCI bus #0 interface, Main Memory Controller, Graphics Aperture controller, 82443BX specific AGP control registers.
- Device 1 = Host-to-AGP interface = “Virtual” PCI-to-PCI Bridge, including AGP address space mapping, normal PCI interface, and associated AGP sideband signal control.

Corresponding configuration registers for both devices are mapped as devices residing on PCI (bus 0). Configuration register layout and functionality for the Device #0 should be inspected carefully, as new features added to the 82443BX initiated a reasonable level of change relative to other proliferation's of the Pentium® Pro processor AGPsets (i.e. 440FX, 440LX). Configuration registers of the 82443BX Device #1 are based on the normal configuration space template of a PCI-to-PCI Bridge as described in the *PCI to PCI Bridge Architecture Specification*.

Figure 3-1 shows the PCI bus hierarchy for the 82443BX). In the PCI bus hierarchy, the primary PCI bus is the highest level bus in the hierarchy and is PCI bus #0. The PCI-to-PCI bridge function provides access to the AGP/PCI bus 0. This bus is below the primary bus in the PCI bus hierarchy and is represented as PCI Bus #1.

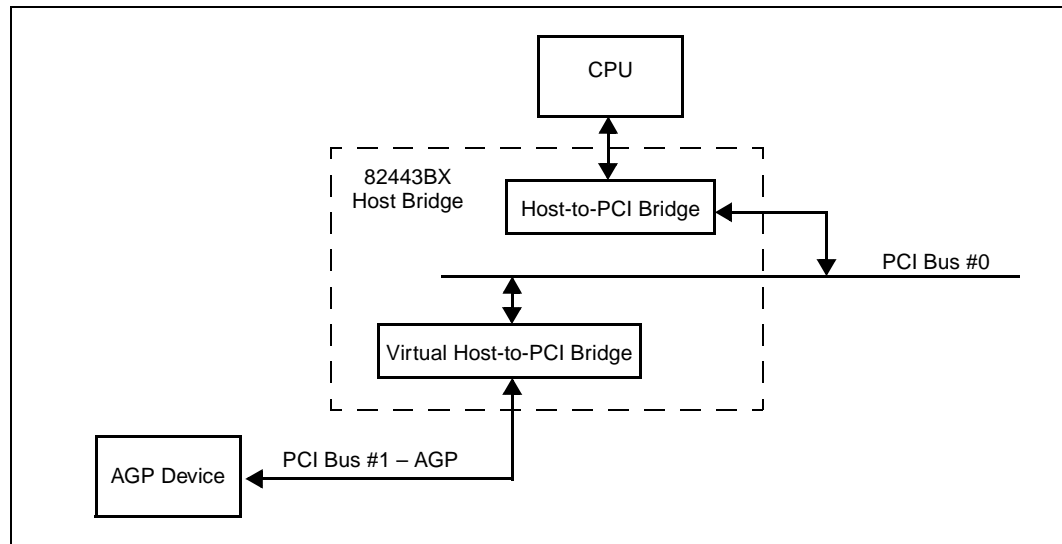
Figure 3-1. 82443BX PCI Bus Hierarchy

3.2.1 Configuration Space Mechanism Overview

The 82443BX supports two bus interfaces: PCI (referenced as Primary PCI) and AGP (referenced as AGP). The AGP interface is treated as a second PCI bus from the configuration point of view. The following sections describe the configuration space mapping mechanism associated with both buses.

Note: The configuration space for device #1 is controlled by the AGP_DIS bit in the PMCR register. When the AGP_DIS bit (PMCR[1]) is set to 0, the configuration space for device #1 is enabled, and the registers for device #1 are accessible through the configuration mechanism defined below. When the AGP_DIS bit (PMCR[1]) is set to 1, the configuration space for device #1 is disabled. All configuration cycles (reads and writes) to device #1 of bus 0 will cause the master abort status bit for device #0/ bus 0 to be set. Configuration read cycles will return data of all 1's. Configuration write cycles will have no effect on the registers.

3.2.2 Routing the Configuration Accesses to PCI or AGP

Routing of configuration accesses to AGP is controlled via PCI-to-PCI bridge normal mechanism using information contained within the PRIMARY BUS NUMBER, the SECONDARY BUS NUMBER, and the SUBORDINATE BUS NUMBER registers of the Host-to-AGP internal "virtual" PCI-to-PCI bridge device. Detailed description of the mechanism for translating CPU I/O bus cycles to configuration cycles on one of the two buses is described below.

To distinguish between PCI configuration cycles targeting the two logical device register sets supported in the 82443BX, this document refers to the Host-to-PCI bridge PCI interface as PCI and the Host- AGP PCI interface as AGP.

3.2.3 PCI Bus Configuration Mechanism Overview

The PCI Bus defines a slot based "configuration space" that allows each device to contain up to 8 functions with each function containing up to 256 8-bit configuration registers. The PCI specification defines two bus cycles to access the PCI configuration space: **Configuration Read** and **Configuration Write**. Memory and I/O spaces are supported directly by the CPU. Configuration space is supported by a mapping mechanism implemented within the chip-set. The PCI specification defines two mechanisms to access configuration space, Mechanism #1 and Mechanism #2. The 82443BX supports only Mechanism #1.

The configuration access mechanism makes use of the CONFADD Register and CONFDATA Register. To reference a configuration register a Dword I/O write cycle is used to place a value into CONFADD that specifies the PCI bus, the device on that bus, the function within the device, and a specific configuration register of the device function being accessed. CONFADD[31] must be 1 to enable a configuration cycle. CONFDATA then becomes a window into the four bytes of configuration space specified by the contents of CONFADD. Any read or write to CONFDATA will result in the Host Bridge translating CONFADD into a PCI configuration cycle.

3.2.3.1 Type 0 Access

If the Bus Number field of CONFADD is 0, a Type 0 Configuration cycle is performed on PCI (i.e. bus #0). CONFADD[10:2] is mapped directly to AD[10:2]. The Device Number field of CONFADD is decoded onto AD[31:11]. The Host-to-PCI Bridge entity within the 82443BX is accessed as Device #0 on the PCI bus segment. The Host- /AGP Bridge entity within the 82443BX is accessed as Device #1 on the PCI bus segment. To access Device #2, the 82443BX will assert AD13, for Device #3 will assert AD14, and so forth up to Device #20 for which will assert AD31. Only one AD line is asserted at a time. All device numbers higher than 20 cause a type 0 configuration access with no IDSEL asserted, which will result in a Master Abort.

3.2.3.2 Type 1 Access

If the Bus Number field of CONFADD is non-zero, then a Type 1 Configuration cycle is performed on PCI bus (i.e. bus #0). CONFADD[23:2] is mapped directly to AD[23:2]. AD[1:0] are driven to 01 to indicate a Type 1 Configuration cycle. All other lines are driven to 0.

3.2.4 AGP Bus Configuration Mechanism Overview

This mechanism is compatible with PCI mechanism #1 supported for the PCI bus as defined above. The configuration mechanism is the same for both accessing AGP or PCI-only devices attached to the AGP interface.

3.2.5 Mapping of Configuration Cycles on AGP

From the AGPset configuration perspective, AGP is seen as another PCI bus interface residing on a Secondary Bus side of the “virtual” PCI-to-PCI bridge referred to as the 82443BX Host- AGP bridge. On the Primary bus side, the “virtual” PCI-to-PCI bridge is attached to the BUS #0 referred to in this document as the PCI interface. The “virtual” PCI-to-PCI bridge entity is used to map Type #1 PCI Bus Configuration cycles on PCI onto Type #0 or Type #1 configuration cycles on the AGP interface.

Type 1 configuration cycles on PCI that have a BUS-NUMBER that matches the SECONDARY-BUS-NUMBER of the “virtual” PCI to PCI bridge will be translated into Type 0 configuration cycles on the AGP interface. Type 1 configuration cycles on PCI that have a BUS-NUMBER that is behind the “virtual” P2P bridge will be translated into Type 1 configuration cycles on the AGP interface.

Note: The PCI bus supports a total of 21 devices by mapping bits 15:11 of the CONFADD to the IDSEL lines on AD[31:11]. For secondary PCI busses (including the AGP bus), only 16 devices are supported by mapping bits 15:11 of the CONFADD to the IDSEL lines (AD[31:16]).

To prepare for mapping of the configuration cycles on AGP the initialization software will go through the following sequence:

1. Scan all devices residing on the PCI bus (i.e., Bus #0) using Type 0 configuration accesses.
2. For every device residing at bus #0 which implements PCI-to-PCI bridge functionality, it will configure the secondary bus of the bridge with the appropriate number and scan further down the hierarchy. This process will include the configuration of the “virtual” PCI-to-PCI Bridge within the 82443BX used to map the AGP address space in a software specific manner.

3.3 Host-to-PCI Bridge Registers (Device 0)

Table 3-1 shows the 82443BX configuration space for device #0.

Table 3-1. 82443BX Register Map — Device 0 (Sheet 1 of 2)

Address Offset	Register Symbol	Register Name	Default Value	Access
00–01h	VID	Vendor Identification	8086h	RO
02–03h	DID	Device Identification	7190h/7192h	RO
04–05h	PCICMD	PCI Command Register	0006h	R/W
06–07h	PCISTS	PCI Status Register	0210h/0200h	RO, R/WC
08	RID	Revision Identification	00/01h/02h	RO
09	—	Reserved	00h	—
0Ah	SUBC	Sub-Class Code	00h	RO
0Bh	BCC	Base Class Code	06h	RO
0Ch	—	Reserved	00h	—
0Dh	MLT	Master Latency Timer	00h	R/W
0Eh	HDR	Header Type	00h	RO
10–13h	APBASE	Aperture Base Address	00000008h	R/W,RO
14–2Bh	—	Reserved	00h	—
2C–2Dh	SVID	Subsystem Vendor Identification	00h	R/WO
2E–2Fh	SID	Subsystem Identification	00h	R/WO
30–33h	—	Reserved	00h	—
34h	CAPPTR	Capabilities Pointer	A0h/00h	RO
35–4Fh	—	Reserved	00h	—
50–53h	NBXCFC	440BX Configuration	[0000h]:[00S0_0000_00S_0S00b]	R/W
54–56h	—	Reserved	00h	—
57h	DRAMC	DRAM Control	00S0_0000b	R/W
58h	DRAMT	DRAM Timing	03h	R/W
59–5Fh	PAM[6:0]	Programmable Attribute Map (7 registers)	00h	R/W
60–67h	DRB[7:0]	DRAM Row Boundary (8 registers)	01h	R/W
68h	FDHC	Fixed DRAM Hole Control	00h	R/W
69–6Eh	MBSC	Memory Buffer Strength Control	0000-0000-0000h	R/W
6F–70h	—	Reserved	00h	—
71h	—	Intel Reserved	1Fh	—
72h	SMRAM	System Management RAM Control	02h	R/W
73h	ESMRAMC	Extended System Management RAM Control.	38h	R/W
74–75h	RPS	SDRAM Row Page Size	0000h	R/W
76–77h	SDRAMC	SDRAM Control Register	0000h	R/W
78–79h	PGPOL	Paging Policy Register	00h	R/W
7Ah	PMCR	Power Management Control Register	0000_S0S0b	R/W
7B–7Ch	SCRR	Suspend CBR Refresh Rate Register	0038h	R/W
7D–7Fh	—	Reserved	00h	—

Table 3-1. 82443BX Register Map — Device 0 (Sheet 2 of 2)

Address Offset	Register Symbol	Register Name	Default Value	Access
80–83h	EAP	Error Address Pointer Register	00000000h	RO, R/WC
84–8Fh	—	Reserved	00h	—
90h	ERRCMD	Error Command Register	80h	R/W
91–92h	ERRSTS	Error Status Register	0000h	R/WC, RO
93h	—	Reserved	00h	R/W
94–97h	—	Intel Reserved	00006104h	—
98–99h	—	Intel Reserved	0500h	—
9Ah	—	Intel Reserved	00h	—
9B–9Fh	—	Reserved	—	—
A0–A3h	ACAPID	AGP Capability Identifier	00100002h 00000000h	RO
A4–A7h	AGPSTAT	AGP Status Register	1F000203h	RO
A8–ABh	AGPCMD	AGP Command Register	00000000h	RW
AC–AFh	—	Reserved	00h	—
B0–B3h	AGPCTRL	AGP Control Register)	00000000h	R/W
B4h	APSIZE	Aperture Size Control Register	00h	R/W
B5–B7h	—	Reserved	00h	—
B8–BBh	ATTBASE	Aperture Translation Table	00000000h	R/W
BCh	—	Reserved	—	—
BDh	—	Reserved	—	—
BE–BFh	—	Reserved	00h	—
C0–C3h	—	Intel Reserved	00000000h	—
C4–C7h	—	Intel Reserved	00000000h	—
C8h	—	Intel Reserved	18h	—
C9h	—	Intel Reserved	0Ch	—
CA–CCh	MBFS	Memory Buffer Frequency Select	000000h	R/W
CD–CFh	—	Reserved	00h	—
D0–D7h	BSPAD	BIOS Scratch Pad	00...00h	R/W
D8–DFh	—	Intel Reserved	000...000h	—
E0–E7h	DWTC	DRAM Write Thermal Throttling Control	000...000h	R/W/L
E8–EFh	DRTC	DRAM Read Thermal Throttling Control	000...000h	R/W/L
F0–F1h	BUFFC	Buffer Control Register	0000h	R/W/L
F2–F7h	—	Intel Reserved	0000F800h	—
F8–FBh	—	Intel Reserved	00000F20h	—
FC–FFh	—	Intel Reserved	00000000h	—

NOTES:

1. The 'S' symbol represents the strapping option.
2. Write operations must not be attempted to the Intel Reserved registers.

3.3.1 VID—Vendor Identification Register (Device 0)

Address Offset: 00–01h
 Default Value: 8086h
 Attribute: Read Only
 Size: 16 bits

The VID Register contains the vendor identification number. This 16-bit register combined with the Device Identification Register uniquely identify any PCI device. Writes to this register have no effect.

Bit	Description
15:0	Vendor Identification Number. This is a 16-bit value assigned to Intel. Intel VID = 8086h.

3.3.2 DID—Device Identification Register (Device 0)

Address Offset: 02–03h
 Default Value: 7190h/7192h
 Attribute: Read Only
 Size: 16 bits

This 16-bit register combined with the Vendor Identification register uniquely identifies any PCI device. Writes to this register have no effect.

Bit	Description
15:0	Device Identification Number. This is a 16 bit value assigned to the 82443BX Host-to-PCI Bridge Function #0. 7190h = When the AGP_DIS bit (PMCR[1]) is set to 0, the DID = 7190h. 7192h = When the AGP_DIS bit is set to 1, the DID = 7192h.

3.3.3 PCICMD—PCI Command Register (Device 0)

Address Offset: 04–05h
 Default: 0006h
 Access: Read/Write
 Size: 16 bits

This 16-bit register provides basic control over the 82443BX PCI interface ability to respond to PCI cycles. The PCICMD Register enables and disables the SERR# signal, 82443BX response to PCI special cycles, and enables and disables PCI bus master accesses to main memory.

Bit	Descriptions
15:10	Reserved.
9	Fast Back-to-Back. Fast back-to-back cycles to different PCI targets are not implemented by the 82443BX. 0 = Hardwired to 0.
8	SERR# Enable (SERRE). Note that this bit only controls SERR# for the PCI bus. Device #1 has its own SERRE bit to control error reporting for the bus conditions occurred on the AGP bus. Two control bits are used in a logical OR manner to control SERR# pin driver. 1 = If this bit is set to a 1, the 82443BX's SERR# signal driver is enabled and SERR# is asserted when an error condition occurs, and the corresponding bit is enabled in the ERRCMD register. The error status is reported in the ERRSTS and PCISTS registers. Also, if this bit is set and the 82443BX's PCI parity error reporting is enabled by the PERRE bit located in this register, then the 82443BX will report address and data parity errors (when it is potential target). 0 = SERR# is never driven by the 82443BX.
7	Address/Data Stepping. Not implemented (hardwired to 0).
6	Parity Error Enable (PERRE). Note that the PERR# signal is not implemented by the 82443BX. 1 = Enable. Address and data parity errors are reported via SERR# mechanism (if enabled via SERRE bit). 0 = Disable. Address and data parity errors are not reported via the 82443BX SERR# signal. (NOTE: Other types of error conditions can be still signaled via SERR# mechanism.) NOTE: The 82443BX PCI bus interface is still required to generate parity even if parity error reporting is disabled via this bit.
5	Reserved.
4	Memory Write and Invalidate Enable. The 82443BX never uses this command. 0 = Hardwired to 0.
3	Special Cycle Enable. The 82443BX ignores all special cycles generated on the PCI. 0 = Hardwired to 0.
2	Bus Master Enable (BME). The 82443BX does not support disabling of its bus master capability on the PCI Bus. 1 = Hardwired to 1, permitting the 82443BX to function as a PCI Bus master.
1	Memory Access Enable (MAE). This bit enables/disables PCI master access to main memory (DRAM). The 82443BX always allows PCI master access to main memory. 1 = Hardwired to 1.
0	I/O Access Enable (IOAE). The 82443BX does not respond to PCI bus I/O cycles. 0 = Hardwired to 0.

3.3.4 PCISTS—PCI Status Register (Device 0)

Address Offset: 06–07h
 Default Value: 0210h/0200h
 Access: Read Only, Read/Write Clear
 Size: 16 bits

PCISTS is a 16-bit status register that reports the occurrence of a PCI master abort and PCI target abort on the PCI bus. PCISTS also indicates the DEVSEL# timing that has been set by the 82443BX hardware for target responses on the PCI bus. Bits [15:12] and bit 8 are read/write clear and bits [10:9] are read only.

Bit	Descriptions
15	Detected Parity Error (DPE). Note that the function of this bit is not affected by the PERRE bit. PERR# is not implemented in the 82443BX. 1 = Indicates 82443BX's detection of a parity error in the address or data phase of PCI bus transactions. 0 = Software sets DPE to 0 by writing a 1 to this bit.
14	Signaled System Error (SSE). 1 = This bit is set to 1 when the 82443BX asserts SERR# for any enabled error condition under device 0. 0 = Software sets SSE to 0 by writing a 1 to this bit.
13	Received Master Abort Status (RMAS). Note that Master abort is the normal and expected termination of PCI special cycles. 1 = When the 82443BX terminates a PCI bus transaction (82443BX is a PCI master) with an unexpected master abort, this bit is set to 1. 0 = Software resets this bit to 0 by writing a 1 to it.
12	Received Target Abort Status (RTAS). 1 = When a 82443BX-initiated PCI transaction is terminated with a target abort, RTAS is set to 1. The 82443BX also asserts SERR# if enabled in the ERRCMD register. 0 = Software resets RTAS to 0 by writing a 1 to it.
11	Signaled Target Abort Status (STAS). The 82443BX does not generate target abort. 0 = Hardwired to a 0
10:9	DEVSEL# Timing (DEVT). This 2-bit field indicates the timing of the DEVSEL# signal when the 82443BX responds as a target on PCI, and indicates the time when a valid DEVSEL# can be sampled by the initiator of the PCI cycle. 01 = Medium (hardwired to 01)
8	Data Parity Detected (DPD). 82443BX does not implement the PERR# pin. However, data parity errors are still detected and reported on SERR# (if enabled by SERRE and PERRE). 0 = Hardwired to 0
7	Fast Back-to-Back (FB2B). The 82443BX as a target does not support fast back-to-back transactions on the PCI bus. 0 = Hardwired to 0
6:5	Reserved.
4	Capability List (CLIST). 1 = When the AGP DIS bit (PMCR[1]) is set to 0, this bit is set to 1. 0 = When the AGP DIS bit (PMCR[1]) is set to 1, this bit is set 0.
3:0	Reserved.

3.3.5 RID—Revision Identification Register (Device 0)

Address Offset: 08h
 Default Value: 02h
 Access: Read Only
 Size: 8 bits

This register contains the revision number of the 82443BX Function #0. These bits are read only and writes to this register have no effect.

Bit	Description
7:0	Revision Identification Number. This is an 8-bit value that indicates the revision identification number for the 82443BX Function #0. B-1 = 02h

3.3.6 SUBC—Sub-Class Code Register (Device 0)

Address Offset: 0Ah
 Default Value: 00h
 Access: Read Only
 Size: 8 bits

This register contains the Sub-Class Code for the 82443BX Function #0. This code is 00h indicating a Host Bridge device. The register is read only.

Bit	Description
7:0	Sub-Class Code (SUBC). This is an 8-bit value that indicates the category of Bridge into which the 82443BX falls. The code is 00h indicating a Host Bridge.

3.3.7 BCC—Base Class Code Register (Device 0)

Address Offset: 0Bh
 Default Value: 06h
 Access: Read Only
 Size: 8 bits

This register contains the Base Class Code of the 82443BX Function #0. This code is 06h indicating a Bridge device. This register is read only.

Bit	Description
7:0	Base Class Code (BASEC). This is an 8-bit value that indicates the Base Class Code for the 82443BX. This code has the value 06h, indicating a Bridge device.

3.3.8 MLT—Master Latency Timer Register (Device 0)

Address Offset: 0Dh
 Default Value: 00h
 Access: Read/Write
 Size: 8 bits

This register controls the amount of time that 82443BX can burst data on the PCI Bus as a PCI master. The MLT[2:0] bits are reserved and assumed to be 0 when determining the Count Value.

Bit	Description
7:3	Master Latency Timer Count Value for PCI Bus Access. MLT is an 8-bit register that controls the amount of time the 82443BX, as a PCI bus master, can burst data on the PCI Bus. The default value of MLT is 00h and disables this function. For example, if the MLT is programmed to 18h, then the value is 24 PCI clocks.
2:0	Reserved.

3.3.9 HDR—Header Type Register (Device 0)

Offset: 0Eh
 Default: 00h
 Access: Read Only
 Size: 8 bits

This register identifies the header layout of the configuration space.

Bit	Descriptions
7:0	Header Type (HEADT). This read only field always returns 0 when read. Writes have no affect on this field.

3.3.10 APBASE—Aperture Base Configuration Register (Device 0)

Offset: 10–13h
 Default: 00000008h
 Access: Read/Write, Read Only
 Size: 32 bits

The APBASE is a normal PCI Base Address register that is used to request the base of the Graphics Aperture. The normal PCI Configuration mechanism defines the base address configuration register such that only a fixed amount of space can be requested (dependent on which bits are hardwired to “0” or behave as hardwired to “0”). To allow for flexibility (of the aperture) an additional register called APSIZE is used as a “back-end” register to control which bits of the APBASE will behave as hardwired to “0”. This register will be programmed by the 82443BX specific BIOS code that will run before any of the generic configuration software is run.

Note: Bit 9 of the NBXCFG register is used to prevent accesses to the aperture range before this register is initialized by the configuration software and appropriate translation table structure has been established in the main memory.

Bit	Description																																																								
31:28	Upper Programmable Base Address bits (R/W). These bits are used to locate the range size selected via lower bits 27:4. Default = 0000b																																																								
27:22	<p>Lower “Hardwired”/Programmable Base Address bits. These bits behave as a “hardwired” or as a programmable depending on the contents of the APSIZE register as defined below:</p> <table border="1"> <thead> <tr> <th>27</th> <th>26</th> <th>25</th> <th>24</th> <th>23</th> <th>22</th> <th>Aperture Size</th> </tr> </thead> <tbody> <tr> <td>r/w</td> <td>r/w</td> <td>r/w</td> <td>r/w</td> <td>r/w</td> <td>r/w</td> <td>4 MB</td> </tr> <tr> <td>r/w</td> <td>r/w</td> <td>r/w</td> <td>r/w</td> <td>r/w</td> <td>0</td> <td>8 MB</td> </tr> <tr> <td>r/w</td> <td>r/w</td> <td>r/w</td> <td>r/w</td> <td>0</td> <td>0</td> <td>16 MB</td> </tr> <tr> <td>r/w</td> <td>r/w</td> <td>r/w</td> <td>0</td> <td>0</td> <td>0</td> <td>32 MB</td> </tr> <tr> <td>r/w</td> <td>r/w</td> <td>0</td> <td>0</td> <td>0</td> <td>0</td> <td>64 MB</td> </tr> <tr> <td>r/w</td> <td>0</td> <td>0</td> <td>0</td> <td>0</td> <td>0</td> <td>128 MB</td> </tr> <tr> <td>0</td> <td>0</td> <td>0</td> <td>0</td> <td>0</td> <td>0</td> <td>256 MB</td> </tr> </tbody> </table> <p>Bits 27:22 are controlled by the bits 5:0 of the APSIZE register in the following manner: If bit APSIZE[5]=0 then APBASE[27]=0 and if APSIZE[5]=1 then APBASE[27]=r/w (read/write). The same applies correspondingly to other bits.</p> <p>Default for APSIZE[5:0]=000000b forces default APBASE[27:22] =000000b (i.e., all bits respond as “hardwired” to 0). This provides a default to the maximum aperture size of 256 MB. The 82443BX specific BIOS is responsible for selecting smaller size (if required) before PCI configuration software runs and establishes the system address map.</p>	27	26	25	24	23	22	Aperture Size	r/w	r/w	r/w	r/w	r/w	r/w	4 MB	r/w	r/w	r/w	r/w	r/w	0	8 MB	r/w	r/w	r/w	r/w	0	0	16 MB	r/w	r/w	r/w	0	0	0	32 MB	r/w	r/w	0	0	0	0	64 MB	r/w	0	0	0	0	0	128 MB	0	0	0	0	0	0	256 MB
27	26	25	24	23	22	Aperture Size																																																			
r/w	r/w	r/w	r/w	r/w	r/w	4 MB																																																			
r/w	r/w	r/w	r/w	r/w	0	8 MB																																																			
r/w	r/w	r/w	r/w	0	0	16 MB																																																			
r/w	r/w	r/w	0	0	0	32 MB																																																			
r/w	r/w	0	0	0	0	64 MB																																																			
r/w	0	0	0	0	0	128 MB																																																			
0	0	0	0	0	0	256 MB																																																			
21:4	Hardwired to “0”. This forces minimum aperture size selected by this register to be 4MB.																																																								
3	Prefetchable (RO). This bit is hardwired to “1” to identify the Graphics Aperture range as a prefetchable (i.e., the device returns all bytes on reads regardless of the byte enables), and the 82443BX may merge processor writes into this range without causing errors.																																																								
2:1	Type (RO). These bits determine addressing type and they are hardwired to “00” to indicate that address range defined by the upper bits of this register can be located anywhere in the 32-bit address space.																																																								
0	Memory Space Indicator (RO). Hardwired to “0” to identify aperture range as a memory range.																																																								

3.3.11 SVID—Subsystem Vendor Identification Register (Device 0)

Offset: 2C–2Dh
 Default: 0000h
 Access: Read/Write Once
 Size: 16 bits

Bit	Description
15:0	Subsystem Vendor ID (R/WO). This value is used to identify the vendor of the subsystem. The default value is 00h. This field should be programmed during boot-up. After this field is written once, it becomes read only.

3.3.12 SID—Subsystem Identification Register (Device 0)

Offset: 2E–2Fh
 Default: 0000h
 Access: Read/Write Once
 Size: 16 bits

Bit	Description
15:0	Subsystem ID (R/WO). This value is used to identify a particular subsystem. The default value is 00h. This field should be programmed during boot-up. After this field is written once, it becomes read only.

3.3.13 CAPPTR—Capabilities Pointer Register (Device 0)

Offset: 34h
 Default: A0h/00h
 Access: Read Only
 Size: 8 bits

The CAPPTR provides the offset that is the pointer to the location where the AGP normal registers are located.

Bit	Description
7:0	Pointer to the start of AGP normal register block. A0h = When the AGP_DIS bit (PMCR[1]) is set to 0, the value in this field is A0h. 00h = When the AGP_DIS bit (PMCR[1]) is set to 1, this field is set to 00h.

3.3.14 NBXCFG—NBX Configuration Register (Device 0)

Offset: 50–53h
 Default: bits 31–16: 0000h
 bits 15–0: 00S0-0000-000S-0S00b
 Access: Read/Write, Read Only for strapping options
 Size: 32 bits

Bit	Description
31:24	SDRAM Row Without ECC. Bit[n] of this 8 bit array corresponds to row[n] of the SDRAM array. When reading a SDRAM row (DIMM) which is none-ECC, the 82443BX drives the ECC data lines during the first data transfer in a burst read. 0 = ECC components are populated in this row. The 82443BX will not drive the ECC signals. 1 = ECC components are not populated in this row. The 82443BX will drive the ECC lines in the first read data transferred when this row is addressed.
23:19	Reserved.
18	Host Bus Fast Data Ready Enable (HBFDR). 0 = Assertion of DRAM data on host bus occurs one clock after sampling snoop results. (default) 1 = Assertion of DRAM data on host bus occurs on the same clock the snoop result is being sampled. This mode is faster by one clock cycle.

Bit	Description
17	<p>ECC - EDO static Drive mode.</p> <p>0 = Normal mode of operation (default).</p> <p>1 = ECC signals are always driven. This mode is used in a mobile system. EDO components are used, but ECC components are not populated in any of the DRAM rows.</p>
16	<p>IDSEL_REDIRECT. This is a programmable option to make the 82443BX compatible with 430TX base design. For CPU initiated configuration cycles to PCI, Device 1 which are targeted to the 82443BX's host to AGP bridge:</p> <p>0 = When set to '0' (default), IDSEL1 (or AD12) is allocated to this bridge. The external AD12 is never activated. CPU initiated configuration cycles to BUS0, DEVICE7 are targeted a PCI bus device that its IDSEL input is connected to IDSEL7 (AD18).</p> <p>1 = When set to '1', IDSEL7 (or AD18) is allocated to this bridge. Since it is internal in the 82443BX, the external AD18 is never activated. CPU initiated configuration cycles to BUS0, DEVICE7 are targeted a PCI bus device that its IDSEL input is connected to IDSEL1 (AD12). In some 430TX based systems, this is connected to PIIX4E.</p> <p>Note that CPU initiated configuration cycles to other PCI buses or other devices are normally mapped and are not affected.</p>
15	<p>WSC# Handshake Disable. In the Uni-Processor mode, this bit should be set to '1'. In the Dual-Processor mode where external IOAPIC is used, this bit should be set to '0' (default). Setting this bit to '0', enables the WSC# handshake mechanism.</p>
14	Intel Reserved.
13:12	<p>Host/DRAM Frequency. These bits are used to determine the host and DRAM frequency. Bit 13 is set by an external strapping option at reset. These bits are also used to select the required refresh rate. These bits apply to both SDRAM and EDO, with the exception that the setting '00' for 100 MHz is illegal for an EDO system.</p> <p>00 = 100 MHz</p> <p>01 = Reserved</p> <p>10 = 66 MHz</p> <p>11 = Reserved</p>
11	<p>AGP to PCI Access Enable. When PHLDA# is active or there is an outstanding passive release transaction pending: 1) this bit is set to 1 and the 82443BX allows AGP to PCI traffic, or 2) this bit is set to 0 (default) and the 82443BX blocks AGP to PCI traffic. The AGP to PCI traffic must not target the ISA bus.</p> <p>1 = Enable</p> <p>0 = Disable</p>
10	<p>PCI Agent to Aperture Access Disable. This bit is used to prevent access to the aperture from the PCI side.</p> <p>1 = Disable</p> <p>0 = Enable (default). If this bit is "0" (default) and bit 9 = 1, accesses to the aperture are enabled for the PCI side.</p> <p>Note: This bit is don't care if bit 9 of this register = 0.</p>
9	<p>Aperture Access Global Enable. This bit is used to prevent access to the aperture from any port (CPU, PCI or AGP) before aperture range is established by the configuration software and appropriate translation table in the main DRAM has been initialized. Default is "0". It must be set after system is fully configured for aperture accesses.</p> <p>1 = Enable. Note that this bit globally controls accesses to the aperture. Once enabled, bit 10 provides the next level of control for accesses originated from the PCI side.</p> <p>0 = Disable</p>
8:7	<p>DRAM Data Integrity Mode (DDIM) (R/W). These bits select one of 4 DRAM data integrity modes.</p> <p>00 = Non-ECC (Byte-Wise Writes supported) (Default)</p> <p>01 = EC-only - Error Checking with No correction</p> <p>10 = ECC Mode (Error Checking/Correction)</p> <p>11 = ECC Mode with hardware scrubbing enabled</p>

Bit	Description												
6	<p>ECC Diagnostic Mode Enable (EDME) (R/W).</p> <p>1 = Enable. When this bit is set to 1, the 82443BX will enter ECC Diagnostic test mode and the 82443BX forces the MECC[7:0] lines to 00h for all writes to memory. During reads, the read MECC[7:0] lines are compared against internally generated ECC. Recognized errors are indicated via the ERRSTS register as in normal ECC operation.</p> <p>0 = Normal operation mode (default).</p>												
5	<p>MDA Present (MDAP).</p> <p>This bit is used to indicate the presence of a secondary monochrome adapter on the PCI bus, while the primary graphics controller is on the AGP bus. This bit works in conjunction with the VGA_EN bit (Register 3E, bit 3 of device 1) as follows:</p> <table border="1"> <thead> <tr> <th>VGA_EN</th> <th>MDAP</th> <th>Description</th> </tr> </thead> <tbody> <tr> <td>0</td> <td>X</td> <td>All VGA cycles are sent to PCI. PCI master cycles to the VGA range are not claimed by the 82443BX.</td> </tr> <tr> <td>1</td> <td>0</td> <td>All VGA cycles are sent to AGP. PCI master writes to VGA range are claimed by the 82443BX and forwarded to the AGP bus.</td> </tr> <tr> <td>1</td> <td>1</td> <td>All VGA cycles are sent to AGP, except for cycles in the MDA range (or the aliased ranges defined below). PCI master writes in the VGA range (outside of the MDA range) are claimed by the 82443BX and forwarded to AGP. PCI and AGP master read/writes to the MDA range are ignored by the 82443BX.</td> </tr> </tbody> </table> <p>The MDA ranges are a subset of the VGA ranges as follows: Memory: 0B0000h–0B7FFFh I/O: 3B4h, 3B5h, 3B8h, 3B9h, 3BAh, 3BFh</p>	VGA_EN	MDAP	Description	0	X	All VGA cycles are sent to PCI. PCI master cycles to the VGA range are not claimed by the 82443BX.	1	0	All VGA cycles are sent to AGP. PCI master writes to VGA range are claimed by the 82443BX and forwarded to the AGP bus.	1	1	All VGA cycles are sent to AGP, except for cycles in the MDA range (or the aliased ranges defined below). PCI master writes in the VGA range (outside of the MDA range) are claimed by the 82443BX and forwarded to AGP. PCI and AGP master read/writes to the MDA range are ignored by the 82443BX.
VGA_EN	MDAP	Description											
0	X	All VGA cycles are sent to PCI. PCI master cycles to the VGA range are not claimed by the 82443BX.											
1	0	All VGA cycles are sent to AGP. PCI master writes to VGA range are claimed by the 82443BX and forwarded to the AGP bus.											
1	1	All VGA cycles are sent to AGP, except for cycles in the MDA range (or the aliased ranges defined below). PCI master writes in the VGA range (outside of the MDA range) are claimed by the 82443BX and forwarded to AGP. PCI and AGP master read/writes to the MDA range are ignored by the 82443BX.											
4	Reserved.												
3	<p>USWC Write Post During I/O Bridge Access Enable (UWPIO) (R/W).</p> <p>1 = Enable. Host USWC writes to PCI memory are posted.</p> <p>0 = Disable. Posting of USWC is not allowed.</p>												
2	<p>In-Order Queue Depth (IOQD) (RO). This bit reflects the value sampled on A7# on the deassertion of the CPURST#. It indicates the depth of the Pentium® Pro processor bus in-order queue (i.e., level of Pentium Pro processor bus pipelining).</p> <p>1 = In-order queue = maximum. If A7# is sampled "1" (i.e., undriven on the Pentium Pro processor bus), the depth of the Pentium Pro processor bus in-order queue is configured to the maximum allowed by the Pentium Pro processor protocol (i.e., 8). However, the actual maximum supported by the 82443BX is 4, and it is controlled by the 82443BX's Pentium Pro processor interface logic using the BNR# signaling mechanism.</p> <p>0 = A7# is sampled asserted (i.e., "0"). The depth of the Pentium Pro processor bus in-order queue is set to 1 (i.e., no pipelining support on the Pentium Pro processor bus).</p> <p>NOTE: During reset, A7# can be driven either by the 82443BX or by an external source as defined by the strapping option on the MAB11# pin.</p>												
1:0	Reserved.												

3.3.15 DRAMC—DRAM Control Register (Device 0)

Address Offset: 57h
 Default Value: 00S0_0000b
 Access: Read/Write
 Size: 8 bits

Bit	Description												
7:6	Reserved.												
5	<p>Module Mode Configuration (MMCONFIG). This bit is set by an external strapping option. The combination of this bit and the SDRAMPWR bit (SDRAMC register) determine the functioning of the CKE signals as defined as follows:</p> <table border="1"> <thead> <tr> <th>SDRAMPWR</th> <th>MMCONFIG</th> <th>CKE Operation</th> </tr> </thead> <tbody> <tr> <td>0</td> <td>0</td> <td>3 DIMM, CKE[5:0] driven, self-refresh entry staggered. SDRAM dynamic power down available.</td> </tr> <tr> <td>X</td> <td>1</td> <td>3 DIMM, CKE0 only, self-refresh entry not staggered. SDRAM dynamic power down unavailable.</td> </tr> <tr> <td>1</td> <td>0</td> <td>4 DIMM, GCKE only, self-refresh entry staggered. SDRAM dynamic power down unavailable.</td> </tr> </tbody> </table> <p>NOTE: Under MCONFIG mode, the AGP must be disabled.</p>	SDRAMPWR	MMCONFIG	CKE Operation	0	0	3 DIMM, CKE[5:0] driven, self-refresh entry staggered. SDRAM dynamic power down available.	X	1	3 DIMM, CKE0 only, self-refresh entry not staggered. SDRAM dynamic power down unavailable.	1	0	4 DIMM, GCKE only, self-refresh entry staggered. SDRAM dynamic power down unavailable.
SDRAMPWR	MMCONFIG	CKE Operation											
0	0	3 DIMM, CKE[5:0] driven, self-refresh entry staggered. SDRAM dynamic power down available.											
X	1	3 DIMM, CKE0 only, self-refresh entry not staggered. SDRAM dynamic power down unavailable.											
1	0	4 DIMM, GCKE only, self-refresh entry staggered. SDRAM dynamic power down unavailable.											
4:3	<p>DRAM Type (DT). This field indicates the DRAM type used to populate the entire array. When set to 00, EDO timings are used for all cycles to main memory. When set to 01, SDRAM timings are used for all cycles to memory. When set to 10, timings for memory cycles accommodate Registered SDRAMs. For registered SDRAM timings, all address and control lines to the SDRAMs are assumed to be registered, while memory data and ECC bits are not registered. EDO, SDRAM and Registered SDRAM cannot be mixed within a system.</p> <p>00 = EDO 01 = SDRAM 10 = Registered SDRAM 11 = Reserved</p> <p>NOTE: When PCIRST# assertion occurs during POS/STR, this bit is not reset to '0'.</p>												
2:0	<p>DRAM Refresh Rate (DRR). The DRAM refresh rate is adjusted according to the frequency selected by this field. Disabling the refresh cycle (000) results in the eventual loss of DRAM data. Changing DRR value will reset the refresh request timer. This field is used in conjunction with the SDRAM frequency bits in the NBXCFG register to determine the correct load value for the refresh timer.</p> <p>000 = Refresh Disabled 001 = 15.6 us 010 = 31.2 us 011 = 62.4 us 100 = 124.8 us 101 = 249.6 us 110 = Reserved 111 = Reserved</p> <p>NOTE: When PCIRST# assertion occurs during POS/STR, this bit is not reset to '0'.</p>												

3.3.16 DRAMT—DRAM Timing Register (Device 0)

Address Offset: 58h
 Default Value: 03h
 Access: Read/Write
 Size: 8 bits

This 8-bit register controls main memory DRAM timings. Refer to the DRAM section for details regarding the DRAM timings programmed in this register.

Bit	Description
7:2	Reserved.
1	<p>EDO RASx# Wait State (RWS). When RWS = 1, one additional wait state is inserted before RAS# is asserted for row misses. This provides one clock of additional MAX[13:0] setup time to RASx# assertion. This bit does not affect page misses since the MAX[13:0] lines are setup several clocks in advance of RAS# assertion for page misses.</p> <p>0 = 1 tASR 1 = 2 tASR</p>
0	<p>EDO CASx# Wait State (CWS). When CWS = 1, one additional wait state is inserted before the assertion of the first CASx# for page hit cycles. This allows one additional clock of MA setup time to the CASx# for the leadoff page hit cycle. Page miss and row miss timings are not affected by this bit.</p> <p>0 = 1 Tasc 1 = 2 Tasc</p>

3.3.17 PAM[6:0]—Programmable Attribute Map Registers (Device 0)

Address Offset: 59h (PAM0) – 5Fh (PAM6)
 Default Value: 00h
 Attribute: Read/Write

The 82443BX allows programmable memory attributes on 13 *Legacy* memory segments of various sizes in the 640 KB to 1 MB address range. Seven Programmable Attribute Map (PAM) Registers are used to support these features. Cacheability of these areas is controlled via the MTRR registers in the Pentium Pro processor. Two bits are used to specify memory attributes for each memory segment. These bits apply to both host accesses and PCI initiator accesses to the PAM areas. These attributes are:

RE Read Enable. When RE = 1, the host read accesses to the corresponding memory segment are claimed by the 82443BX and directed to main memory. Conversely, when RE = 0, the host read accesses are directed to PCI.

WE Write Enable. When WE = 1, the host write accesses to the corresponding memory segment are claimed by the 82443BX and directed to main memory. Conversely, when WE = 0, the host write accesses are directed to PCI.

The RE and WE attributes permit a memory segment to be Read Only, Write Only, Read/Write, or disabled. For example, if a memory segment has RE = 1 and WE = 0, the segment is Read Only.

Each PAM Register controls two regions, typically 16 KB in size. Each of these regions has a 4-bit field. The four bits that control each region have the same encoding and are defined in Table 3-2.

Table 3-2. Attribute Bit Assignment

Bits [7, 3] Reserved	Bits [6, 2] Reserved	Bits [5, 1] WE	Bits [4, 0] RE	Description
x	x	0	0	Disabled. DRAM is disabled and all accesses are directed to PCI. The 82443BX does not respond as a PCI target for any read or write access to this area.
x	x	0	1	Read Only. Reads are forwarded to DRAM and writes are forwarded to PCI for termination. This write protects the corresponding memory segment. The 82443BX will respond as a PCI target for read accesses but not for any write accesses.
x	x	1	0	Write Only. Writes are forwarded to DRAM and reads are forwarded to the PCI for termination. The 82443BX will respond as a PCI target for write accesses but not for any read accesses.
x	x	1	1	Read/Write. This is the normal operating mode of main memory. Both read and write cycles from the host are claimed by the 82443BX and forwarded to DRAM. The 82443BX will respond as a PCI target for both read and write accesses.

As an example, consider a BIOS that is implemented on the expansion bus. During the initialization process, the BIOS can be shadowed in main memory to increase the system performance. When BIOS is shadowed in main memory, it should be copied to the same address location. To shadow the BIOS, the attributes for that address range should be set to write only. The BIOS is shadowed by first doing a read of that address. This read is forwarded to the expansion bus. The host then does a write of the same address, which is directed to main memory. After the BIOS is shadowed, the attributes for that memory area are set to read only so that all writes are forwarded to the expansion bus. Table 3-3 shows the PAM registers and the associated attribute bits:

Table 3-3. PAM Registers and Associated Memory Segments

PAM Reg	Attribute Bits				Memory Segment	Comments	Offset
PAM0[3:0]	Reserved						59h
PAM0[7:4]	R	R	WE	RE	0F0000h – 0FFFFFh	BIOS Area	59h
PAM1[3:0]	R	R	WE	RE	0C0000h – 0C3FFFh	ISA Add-on BIOS ¹	5Ah
PAM1[7:4]	R	R	WE	RE	0C4000h – 0C7FFFh	ISA Add-on BIOS ¹	5Ah
PAM2[3:0]	R	R	WE	RE	0C8000h – 0CBFFFh	ISA Add-on BIOS ¹	5Bh
PAM2[7:4]	R	R	WE	RE	0CC000h – 0CFFFFh	ISA Add-on BIOS ¹	5Bh
PAM3[3:0]	R	R	WE	RE	0D0000h – 0D3FFFh	ISA Add-on BIOS	5Ch
PAM3[7:4]	R	R	WE	RE	0D4000h – 0D7FFFh	ISA Add-on BIOS	5Ch
PAM4[3:0]	R	R	WE	RE	0D8000h – 0DBFFFh	ISA Add-on BIOS	5Dh
PAM4[7:4]	R	R	WE	RE	0DC000h – 0DFFFFh	ISA Add-on BIOS	5Dh
PAM5[3:0]	R	R	WE	RE	0E0000h – 0E3FFFh	BIOS Extension	5Eh
PAM5[7:4]	R	R	WE	RE	0E4000h – 0E7FFFh	BIOS Extension	5Eh
PAM6[3:0]	R	R	WE	RE	0E8000h – 0EBFFFh	BIOS Extension	5Fh
PAM6[7:4]	R	R	WE	RE	0EC000h – 0EFFFFh	BIOS Extension	5Fh

NOTE:

1. The C0000h to CFFFFh segment can be used for SMM space if enabled by the SMRAM register

DOS Application Area (00000h–9FFFh)

The DOS area is 640 KB and it is further divided into two parts. The 512 KB area at 0 to 7FFFFh is always mapped to the main memory controlled by the 82443BX, while the 128 KB address range from 080000 to 09FFFFh can be mapped to PCI or to main DRAM. By default this range is mapped to main memory and can be declared as a main memory hole (accesses forwarded to PCI) via 82443BX's FDHC configuration register.

Video Buffer Area (A0000h–BFFFFh)

This 128 KB area is not controlled by attribute bits. The host-initiated cycles in this region are always forwarded to either PCI or AGP unless this range is accessed in SMM mode. *Routing of accesses is controlled by the Legacy VGA control mechanism of the “virtual” PCI-to-PCI bridge device embedded within the 82443BX.*

This area can be programmed as SMM area via the SMRAM register. When used as a SMM space this range can not be accessed from PCI or AGP.

Expansion Area (C0000h–DFFFFh)

This 128 KB area is divided into eight 16 KB segments which can be assigned with different attributes via PAM control register as defined by Table 3-3.

Extended System BIOS Area (E0000h–EFFFFh)

This 64 KB area is divided into four 16 KB segments which can be assigned with different attributes via PAM control register as defined by the Table 3-3.

System BIOS Area (F0000h–FFFFFFh)

This area is a single 64 KB segment which can be assigned with different attributes via PAM control register as defined by the Table 3-3.

3.3.18 DRB[0:7]—DRAM Row Boundary Registers (Device 0)

Address Offset: 60h (DRB0) – 67h (DRB7)
 Default Value: 01h
 Access: Read/Write
 Size: 8 bits/register

The 82443BX supports 8 physical rows of DRAM. The width of a row is 64 bits. The DRAM Row Boundary Registers define upper and lower addresses for each DRAM row. Contents of these 8-bit registers represent the boundary addresses in 8 MB granularity. For example, a value of 01h indicates 8 MB.

60h DRB0 = Total memory in row0 (in 8 MB)
 61h DRB1 = Total memory in row0 + row1 (in 8 MB)
 62h DRB2 = Total memory in row0 + row1 + row2 (in 8 MB)
 63h DRB3 = Total memory in row0 + row1 + row2 + row3 (in 8 MB)
 64h DRB4 = Total memory in row0 + row1 + row2 + row3 + row4 (in 8 MB)
 65h DRB5 = Total memory in row0 + row1 + row2 + row3 + row4 + row5 (in 8 MB)
 66h DRB6 = Total memory in row0 + row1 + row2 + row3 + row4 + row5 + row6 (in 8 MB)
 67h DRB7 = Total memory in row0 + row1 + row2 + row3 + row4 + row5 + row6 + row7 (in 8 MB)

The DRAM array can be configured with single or double-sided DIMMs using 2Mx8, 4Mx16, or 8Mx8 parts. The array also supports x4 width DRAM components on registered DIMMs. Each register defines an address range that will cause a particular CS# line (or RAS# in the EDO case) to be asserted (e.g., if the first DRAM row is minus 8 MB, then accesses within the 0 to 8 MByte range will cause CSx0#/RASx0# to be asserted). The DRAM Row Boundary (DRB) Registers are programmed with an 8-bit upper address limit value. This upper address limit is compared to bits [30:23] of the requested address, for each row, to determine if DRAM is being targeted.

Note: DRAM is selected only if address[31:30] are zero.

Bit	Description
7:0	Row Boundary Address. This 8-bit value is compared against address lines A[30:23] to determine the upper address limit of a particular row (i.e., DRB minus previous DRB = row size). NOTE: When PCIRST# assertion occurs during POS/STR, these bits are not reset to '01h'.

Row Boundary Address

These 8 bit values represent the upper address limits of the eight rows (i.e., this row minus previous row = row size). Unpopulated rows have a value equal to the previous row (row size = 0). DRB7 reflects the maximum amount of DRAM in the system. The top of memory is determined by the value written into DRB7.

Note: The 82443BX supports a maximum of 1 GB of DRAM using registered SDRAM DIMMs. (an example of this configuration is 4 double-sided registered DIMMs using 16Mx4 parts).

As an example of a general purpose configuration where eight physical rows are configured for either single-sided or double-sided DIMMs, the memory array would be configured like the one shown in Figure 3-2. In this configuration, the 82443BX drives eight CS# signals directly to the DIMM rows. If single-sided DIMMs are populated, the even CS# signals are used and the odd CS#s are not connected. If double-sided DIMMs are used, all four CS# signals are used per DIMM.

Figure 3-2. SDRAM DIMMs and Corresponding DRB Registers

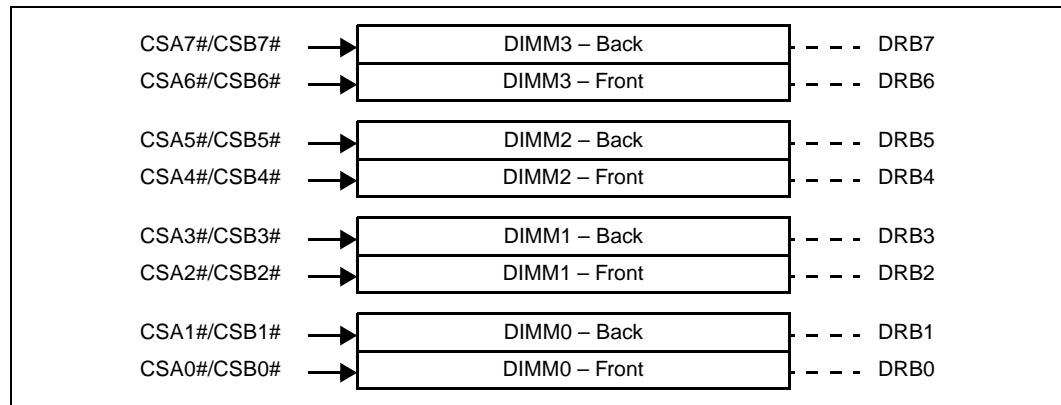

The following 2 examples describe how the DRB Registers are programmed for cases of single-sided and double-sided DIMMs on a motherboard.

Example #1 Single-sided DIMMs

Assume a total of 16 MB of DRAM are required using single-sided 1MB x 64 DIMMs. In this configuration, two DIMMs are required.

DRB0 = 01h	populated (1 DIMM, 8 Mbyte this row)
DRB1 = 01h	empty row
DRB2 = 02h	populated (1 DIMM, 8 Mbyte this row)
DRB3 = 02h	empty row
DRB4 = 02h	empty row
DRB5 = 02h	empty row
DRB6 = 02h	empty row
DRB7 = 02h	empty row

Example #2 Mixed Single-/Double-sided DIMMs

As another example, consider a system that is initially shipped with 8 MB of memory using a 1M x 64 DIMM and that rest of the memory array should be upgradable up to a maximum supported memory of 200 MB. This can be handled by further populating the array with one 16M x 64 single-sided DIMM (one row) and one 8M x 64 double-sided DIMM (two rows), yielding a total of 200 MB of DRAM. The DRB Registers are programmed as follows:

DRB0 = 01h	populated with 8 MB, 1MB x 64 single-sided DIMM
DRB1 = 01h	empty row
DRB2 = 05h	populated with 32 MB, 1/2 of 8M x 64 DIMM
DRB3 = 09h	populated with 32 MB, the other 1/2 of 8M x 64 DIMM
DRB4 = 19h	populated with 128 MB, 16M x 64 single-sided DIMM
DRB5 = 19h	empty row
DRB6 = 19h	empty row
DRB7 = 19h	empty row

3.3.19 FDHC—Fixed DRAM Hole Control Register (Device 0)

Address Offset: 68h
 Default Value: 00h
 Access: Read/Write
 Size: 8 bits

This 8-bit register controls 2 fixed DRAM holes: 512 KB – 640 KB and 15 MB –16 MB.

Bit	Description
7:6	<p>Hole Enable (HEN). This field enables a memory hole in DRAM space. Host cycles matching an enabled hole are passed on to PCI. PCI cycles matching an enabled hole will be ignored by the 82443BX (no DEVSEL#). NOTE: A selected hole is not remapped.</p> <p>00 = None 01 = 512 KB–640 KB (128 KB bytes) 10 = 15 MB – 16 MB (1 MB byte) 11 = Reserved</p>
5:0	Reserved.

3.3.20 MBSC—Memory Buffer Strength Control Register (Device 0)

Address Offset: 69–6Eh
 Default Value: 000000000000h
 Access: Read/Write
 Size: 48 bits

This register programs the various DRAM interface signal buffer strengths, based on non-mixed memory configurations of DRAM type (EDO or SDRAM), DRAM density (x8, x16, or x32), DRAM technology (16MB or 64 MB), and rows populated. Note that x4 DRAM may only be supported when used on registered DIMMs.

Note: The choice of 100 MHz or 66 MHz buffer is independent of bus frequency. It is possible to select a 100 MHz memory buffer even though the bus frequency is 66 MHz (and vice versa).

Bit	Description
47:40	Reserved
39:38	MAA[13:0], WEA#, SRASA#, SCASA# Buffer Strengths. This field sets the buffer strength for the MAA[13:0], WEA#, SRASA#, SCASA# pins. 00 = 1x (66 MHz & 100 MHz) 01 = Reserved (Invalid setting) 10 = 2x (66 MHz & 100 MHz) 11 = 3x (66 MHz & 100 MHz)
37:36	MAB[12:11, 9:0]# & MAB[13,10], WEB#, SRASB#, SCASB# Buffer Strengths. This field sets the buffer strength for MAB[12:11, 9:0]# & MAB[13,10], WEB#, SRASB#, SCASB# pins. Note that the address's MAB# are inverted copies of MAA, with the exception of MAB[13,10]. 00 = 1x (66 MHz & 100 MHz) 01 = Reserved (Invalid setting) 10 = 2x (66 MHz & 100 MHz) 11 = 3x (66 MHz & 100 MHz)
35:34	MD [63:0] Buffer Strength Control 2. 4 DIMM FET Configuration: This field sets the buffer strength for the MD[63:0] path that is connected to DIMM2 and DIMM3. The buffer strength is programmable based on the SDRAM load in detected in DIMM slots 2&3 . This path is enabled when FENA is asserted (High) by the 82443BX. 3 DIMM & 4 DIMM non-FET Configuration: This field should be programmed to the same value as MD[63:0] Buffer Strength Control 1. This buffer strength is programmable based upon the SDRAM load detected in all DIMM connectors. 00 = 1x (66 MHz & 100 MHz) 01 = Reserved (Invalid setting) 10 = 2x (66 MHz & 100 MHz) 11 = 3x (100 MHz only)
33:32	MD [63:0] Buffer Strength Control 1. 4 DIMM FET Configuration: This field sets the buffer strength for the MD[63:0] path that is connected to DIMM0 and DIMM1. The buffer strength is programmable based upon the SDRAM load in detected in DIMM slots 0&1 . This path is enabled when FENA is asserted (Low) by the 82443BX. 3 DIMM & 4 DIMM non-FET Configurations: The buffer strength is programmable based upon the SDRAM load detected in all DIMM connectors. 00 = 1x (66 MHz & 100 MHz) 01 = Reserved (Invalid setting) 10 = 2x (66 MHz & 100 MHz) 11 = 3x (100 MHz only)

Bit	Description
31:30	<p>MECC [7:0] Buffer Strength Control 2.</p> <p>4 DIMM FET Configuration: This field sets the buffer strength for the MECC[7:0] path that is connected to DIMM2 and DIMM3. The buffer strength is programmable based upon the SDRAM ECC load detected in DIMM slots 2&3. This path is enabled when FENA is deasserted (High) by the 82443BX.</p> <p>3 DIMM & 4 DIMM non-FET Configurations: This field should be programmed to the same value as MECC[7:0] Buffer Strength Control 1. This buffer strength is programmable based upon the SDRAM load detected in all DIMM connectors.</p> <p>00 = 1x (66 MHz & 100 MHz) 01 = Reserved (Invalid setting) 10 = 2x (66 MHz & 100 MHz) 11 = 3x (100 MHz only)</p>
29:28	<p>MECC [7:0] Buffer Strength Control 1.</p> <p>4 DIMM FET Configuration: This field sets the buffer strength for the MECC[7:0] path that is connected to DIMM0 and DIMM1. The buffer strength is programmable based upon the SDRAM ECC load detected in DIMM slots 0&1. This path is enabled when FENA is deasserted (High) by the 82443BX.</p> <p>3 DIMM & 4 DIMM non-FET Configuration: The buffer strength is programmable based upon the SDRAM ECC load detected in all DIMM slots.</p> <p>00 = 1x (66 MHz & 100 MHz) 01 = Reserved (Invalid setting) 10 = 2x (66 MHz & 100 MHz) 11 = 3x (100 MHz only)</p>
27:26	<p>CSB7#/CKE5 Buffer Strength. This field sets the buffer strength for CSB7#/CKE5 pins.</p> <p>00 = 1x (66 MHz & 100 MHz) 01 = Reserved (Invalid setting) 10 = 2x (66 MHz & 100 MHz) 11 = 3x (66 MHz & 100 MHz)</p>
25:24	<p>CSA7#/CKE3 Buffer Strength. This field sets the buffer strength for CSA7#/CKE3 pins.</p> <p>00 = 1x (66 MHz & 100 MHz) 01 = Reserved (Invalid setting) 10 = 2x (66 MHz & 100 MHz) 11 = 3x (66 MHz & 100 MHz)</p>
23:22	<p>CSB6#/CKE4 Buffer Strength. This field sets the buffer strength for CSB6#/CKE4 pins.</p> <p>00 = 1x (66 MHz & 100 MHz) 01 = Reserved (Invalid setting) 10 = 2x (66 MHz & 100 MHz) 11 = 3x (66 MHz & 100 MHz)</p>
21:20	<p>CSA6#/CKE2 Buffer Strength. This field sets the buffer strength for CSA6#/CKE2 pins.</p> <p>00 = 1x (66 MHz & 100 MHz) 01 = Reserved (Invalid setting) 10 = 2x (66 MHz & 100 MHz) 11 = 3x (66 MHz & 100 MHz)</p>
19	<p>CSA5#/RASA5#, CSB5#/RASB5# Buffer Strength. This field sets the buffer strength for the CSA5#/RASA5#, CSB5#/RASB5# pins.</p> <p>0 = 1x (66 MHz & 100 MHz) 1 = 2x (66 MHz & 100 MHz)</p>
18	<p>CSA4#/RASA4#, CSB4#/RASB4# Buffer Strength. This field sets the buffer strength for the CSA4#/RASA4#, CSB4#/RASB4# pins.</p> <p>0 = 1x (66 MHz & 100 MHz) 1 = 2x (66 MHz & 100 MHz)</p>
17	<p>CSA3#/RASA3#, CSB3#/RASB3# Buffer Strength. This field sets the buffer strength for the CSA3#/RASA3#, CSB3#/RASB3# pins.</p> <p>0 = 1x (66 MHz & 100 MHz) 1 = 2x (66 MHz & 100 MHz)</p>

Bit	Description
16	CSA2#/RASA2#, CSB2#/RASB2# Buffer Strength. This field sets the buffer strength for the CSA2#/RASA2#, CSB2#/RASB2# pins. 0 = 1x (66 MHz & 100 MHz) 1 = 2x (66 MHz & 100 MHz)
15	CSA1#/RASA1#, CSB1#/RASB1# Buffer Strength. This field sets the buffer strength for the CSA1#/RASA1#, CSB1#/RASB1# pins. 0 = 1x (66 MHz & 100 MHz) 1 = 2x (66 MHz & 100 MHz)
14	CSA0#/RASA0#, CSB0#/RASB0# Buffer Strength. This field sets the buffer strength for the CSA0#/RASA0#, CSB0#/RASB0# pins. 0 = 1x (66 MHz & 100 MHz) 1 = 2x (66 MHz & 100 MHz)
13:12	DQMA5/CASA5# Buffer Strength. This field sets the buffer strength for the DQMA5/CASA5# pins. 00 = 1x (66 MHz & 100 MHz) 01 = Reserved (Invalid setting) 10 = 2x (66 MHz & 100 MHz) 11 = 3x (66 MHz only)
11:10	DQMA1/CASA1# Buffer Strength. This field sets the buffer strength for the DQMA1/CASA1# pin. 00 = 1x (66 MHz & 100 MHz) 01 = Reserved (Invalid setting) 10 = 2x (66 MHz & 100 MHz) 11 = 3x (66 MHz & 100 MHz)
9:8	DQMB5/CASB5# Buffer Strength. This field sets the buffer strength for the DQMB5/CASB5# pin. 00 = 1x (66 MHz & 100 MHz) 01 = Reserved (Invalid setting) 10 = 2x (66 MHz & 100 MHz) 11 = 3x (66 MHz only)
7:6	DQMB1/CASB1# Buffer Strength. This field sets the buffer strength for the DQMB1/CASB1# pin. 00 = 1x (66 MHz & 100 MHz) 01 = Reserved (Invalid setting) 10 = 2x (66 MHz & 100 MHz) 11 = 3x (66 MHz only)
5:4	DQMA[7:6,4:2,0]/CASA[7:6,4:2,0]# Buffer Strength. This field sets the buffer strength for the DQMA[7:6]/CASA[7:6]#, DQMA[4:2]/CASA[4:2]#, and the DQMA[0]/CASA[0]# pins. 00 = 1x (66 MHz & 100 MHz) 01 = Reserved (Invalid setting) 10 = 2x (66 MHz & 100 MHz) 11 = 3x (66 MHz & 100 MHz)
3:2	CKE1/GCKE Buffer Strength. This field sets the buffer strength for the CKE1 pin. 00 = 1x (66 MHz & 100 MHz) 01 = Reserved (Invalid setting) 10 = 2x (66 MHz & 100 MHz) 11 = 3x (66 MHz & 100 MHz)
1:0	CKE0/FENA Buffer Strength. This field sets the buffer strength for the CKE0/FENA pin. 00 = 1x (66 MHz & 100 MHz) 01 = Reserved (Invalid setting) 10 = 2x (66 MHz & 100 MHz) 11 = 3x (66 MHz & 100 MHz)

3.3.21 SMRAM—System Management RAM Control Register (Device 0)

Address Offset: 72h
 Default Value: 02h
 Access: Read/Write
 Size: 8 bits

The SMRAMC register controls how accesses to Compatible and Extended SMRAM spaces are treated. The Open, Close, and Lock bits function only when G_SMFRAME bit is set to a 1. Also, the OPEN bit must be reset before the LOCK bit is set.

Bit	Description
7	Reserved
6	SMM Space Open (D_OPEN). When D_OPEN=1 and D_LCK=0, the SMM space DRAM is made visible even when SMM decode is not active. This is intended to help BIOS initialize SMM space. Software should ensure that D_OPEN=1 and D_CLS=1 are not set at the same time. When D_LCK is set to a 1, D_OPEN is reset to 0 and becomes read only.
5	SMM Space Closed (D_CLS). When D_CLS = 1 SMM space DRAM is not accessible to data references, even if SMM decode is active. Code references may still access SMM space DRAM. This will allow SMM software to reference "through" SMM space to update the display even when SMM is mapped over the VGA range. Software should ensure that D_OPEN=1 and D_CLS=1 are not set at the same time.
4	SMM Space Locked (D_LCK). When D_LCK is set to 1 then D_OPEN is reset to 0 and D_LCK, D_OPEN, H_SMRAM_EN, TSEG_SZ, TSEG_EN and DRB7 become read only. D_LCK can be set to 1 via a normal configuration space write but can only be cleared by a power-on reset. The combination of D_LCK and D_OPEN provide convenience with security. The BIOS can use the D_OPEN function to initialize SMM space and then use D_LCK to "lock down" SMM space in the future so that no application software (or BIOS itself) can violate the integrity of SMM space, even if the program has knowledge of the D_OPEN function.
3	Global SMRAM Enable (G_SMFRAME). If G_SMFRAME is set to a 1 and H_SMRAM_EN is set to 0, then Compatible SMRAM functions are enabled, providing 128 KB of DRAM accessible at the A0000h address while in SMM (ADS# with SMM decode). To enable Extended SMRAM function this bit has to be set to 1. Refer to the section on SMM for more details. Once D_LCK is set, this bit becomes read only.
2:0	Compatible SMM Space Base Segment (C_BASE_SEG) (RO). This field programs the location of SMM space. "SMM DRAM" is not remapped. It is simply "made visible" if the conditions are right to access SMM space, otherwise the access is forwarded to PCI. 010 = Hardwired to 010 to indicate that the 82443BX supports the SMM space at A0000h–BFFFFh.

3.3.22 ESMRAMC—Extended System Management RAM Control Register (Device 0)

Address Offset: 73h
 Default Value: 38h
 Access: Read/Write
 Size: 8 bits

The Extended SMRAM register controls the configuration of Extended SMRAM space. The Extended SMRAM (E_SMRAM) memory provides a write-back cacheable SMRAM memory space that is above 1 Mbyte.

Bit	Description
7	<p>H_SMRAM_EN (H_SMRAME). Controls the SMM memory space location (i.e. above 1 Mbyte or below 1 Mbyte).</p> <p>1 = When G_SMRAME is 1 and H_SMRAME is set to 1, the High SMRAM memory space is enabled, the Compatible SMRAM memory is disabled, and accesses in the 0A0000h to 0FFFFFFh range are forwarded to PCI, while SMRAM accesses from 100A0000h to 100FFFFFFh are remapped to DRAM address A0000h to FFFFFh</p> <p>0 = When G_SMRAME is set to a 1 and H_SMRAM_EN is set to 0, then the Compatible SMRAM space is enabled.</p> <p>Once D_LCK is set, this bit becomes read only.</p>
6	<p>E_SMRAM_ERR (E_SMERR).</p> <p>1 = This bit is set when CPU accesses the defined memory ranges in Extended SMRAM (High Memory and T-segment) while not in SMM space and with the D-OPEN bit = 0.</p> <p>0 = It is software's responsibility to clear this bit. The software must write a 1 to this bit to clear it.</p>
5	<p>SMRAM_Cache (SM_CACHE). This bit is forced to '1' by 82443BX.</p>
4	<p>SMRAM_L1_EN (SM_L1). This bit is forced to '1' by 82443BX.</p>
3	<p>SMRAM_L2_EN (SM_L2). This bit is forced to '1' by 82443BX.</p>
2:1	<p>TSEG_SZ[1:0] (T_SZ). Selects the size of the TSEG memory block, if enabled. This memory is taken from the top of DRAM space (i.e., TOM - TSEG_SZ), which is no longer claimed by the memory controller (all accesses to this space are sent to the PCI bus if TSEG_EN is set). The physical address for the extended SMRAM memory appears is from (256M + TOM - TSEG_SZ) to (256M + TOM). This address is remapped to DRAM address (TOM - TSEG_SZ) to TOM. This field decodes as follows:</p> <p>00 = (TOM-128KB) to TOM</p> <p>01 = (TOM-256KB) to TOM</p> <p>10 = (TOM-512KB) to TOM</p> <p>11 = (TOM-1MB) to TOM</p> <p>Once D_LCK is set, this bit becomes read only.</p>
0	<p>TSEG_EN (T_EN). Enabling of SMRAM memory (TSEG, 128 KB, 256 KB, 512 KB or 1 MB of additional SMRAM memory) for Extended SMRAM space only. When G_SMRAME = 1 and TSEG_EN = 1, the TSEG is enabled to appear in the appropriate physical address space. Once D_LCK is set, this bit becomes read only.</p>

3.3.23 RPS—SDRAM Row Page Size Register (Device 0)

Address Offset: 74h–75h
 Default Value: 0000h
 Access: Read/Write
 Size: 16 bits

This register sets the row page size for SDRAM only. For EDO memory, the page size is fixed at 2 KB.

Bit	Description
	Page Size (PS). Each pair of bits in this register indicate the page size used for one row of DRAM. The encoding of the two bit fields.
	Bits[1:0] Page Size
	00 2 KB
	01 4 KB
	10 8 KB
	11 Reserved
15:0	RPS bits Corresponding DRB register
	1:0 DRB[0], row 0
	3:2 DRB[1], row 1
	5:4 DRB[2], row 2
	7:6 DRB[3], row 3
	9:8 DRB[4], row 4
	11:10 DRB[5], row 5
	13:12 DRB[6], row 6
	15:14 DRB[7], row 7

3.3.24 SDRAMC—SDRAM Control Register (Device 0)

Address Offset: 76h–77h
 Default Value: 00h
 Access: Read/Write
 Size: 16 bits

Bit	Description
15:10	Reserved
9:8	Idle/Pipeline DRAM Leadoff Timing (IPDLT). Adds a clock delay to the lead-off clock count when bits 9:8 are set to 01. All other settings are illegal.

Bit	Description
7:5	<p>SDRAM Mode Select (SMS). These bits allow the 82443BX to drive various commands to the SDRAMs. These special modes are intended for initialization at power up.</p> <p>SMS Mode</p> <p>000 Normal SDRAM Operation. (default)</p> <p>001 NOP Command Enable. In this mode all CPU cycles to SDRAM result in NOP Command on the SDRAM interface.</p> <p>010 All Banks Precharge Enable. In this mode all CPU cycles to SDRAM result in an All Banks Precharge Command on the SDRAM interface.</p> <p>011 Mode Register Set Enable. In this mode all CPU cycles to SDRAM result in a mode register set command on the SDRAM interface. The Command is driven on the MAX[13:0] lines. MAX[2:0] must always be driven to 010 for burst of 4 mode. MA3 must be driven to 1 for interleave wrap type. MAX4 needs to be driven to the value programmed in the CAS# Latency bit. MAX[6:5] should always be driven to 01. MAX[12:7] must be driven to 000000. BIOS must calculate and drive the correct host address for each row of memory such that the correct command is driven on the MAX[12:0] lines.</p> <p>100 CBR Enable. In this mode all CPU cycles to SDRAM result in a CBR cycle on the SDRAM interface.</p> <p>101 Reserved.</p> <p>110 Reserved.</p> <p>111 Reserved.</p> <p>Note: BIOS must take into consideration MAB inversion when programming for 3 and 4 DIMM.</p>
4	<p>SDRAMPWR. The SDRAMPWR bit controls how the CKE signals are driven for different DRAM configurations. For a 3 DIMM configuration, SDRAMPWR should be set to '0'. For a 4 DIMM configuration, SDRAMPWR should be set to '1'. In this case the 82443BX drives a single CKE signal (GCKE). The combination of SDRAMPWR and MMCONFIG (DRAMC register) determine the functioning of the CKE signals. Refer to the DRAMC register (Section 3.3.15, "DRAMC—DRAM Control Register (Device 0)" on page 3-19) for more details.</p> <p>Note: When PCIRST# assertion occurs during POS/STR, these bits are not reset to 0.</p>
3	<p>Leadoff Command Timing (LCT). These bits control when the SDRAM command pins (SRASx#, SCASx# and WEx#) and CSx# are considered valid on leadoffs for CPU cycles.</p> <p>0 = 4 CS# Clock</p> <p>1 = 3 CS# Clock</p> <p>The LCT Bit should be initialized by BIOS as recommended below:</p> <ul style="list-style-type: none"> Desktop platforms running at 100 MHz should leave the LCT bit set to its default value of 0. Desktop platforms running at 66 MHz should leave the LCT bit set to its default value of 0, if load on either MAA or MAB signals is > 9. Otherwise, set the LCT bit to 1, if load on both MAA and MAB is ≤ 9. Mobile platforms will be run at 66MHz and should set the LCT bit to 1.
2	<p>CAS# Latency (CL). This bit controls the number of CLKs between when a read command is sampled by the SDRAMs and when the 82443BX samples read data from the SDRAMs. If a given row is populated with a registered SDRAM DIMM, an extra clock is inserted between the read command the when the 82443BX samples read data. For a registered DIMM with CL=2, this bit should be set to 1.</p> <p>0 = 3 DCLK CAS# latency.</p> <p>1 = 2 DCLK CAS# latency.</p>
1	<p>SDRAM RAS# to CAS# Delay (SRCD). This bit controls the number of DCLKs from a Row Activate command to a read or write command.</p> <p>0 = 3 clocks will be inserted between a row activate command and either a read or write command.</p> <p>1 = 2 clocks will be inserted between a row activate and either a read or write command.</p>
0	<p>SDRAM RAS# Precharge (SRP). This bit controls the number of DCLKs for RAS# precharge.</p> <p>0 = 3 clocks of RAS# precharge.</p> <p>1 = 2 clocks of RAS# precharge.</p>

3.3.25 PGPOL—Paging Policy Register (Device 0)

Address Offset: 78–79h
 Default Value: 0000h
 Access: Read/Write
 Size: 16 bits

Bit	Description
15:8	<p>Banks per Row (BPR). Each bit in this field corresponds to one row of the memory array. Bit 15 corresponds to row 7 while bit 8 corresponds to row 0. These bits are defined only for SDRAM systems and define whether the corresponding row has a two bank implementation or a four bank implementation. Those with two banks (bit=0) can have up to two pages open at any given time. Those with four banks (bit=1) can have up to four pages open at any time. Note that the bits referencing empty rows are 'don't care'.</p> <p>0 = 2 banks 1 = 4 banks</p>
7:5	Reserved.
4	Intel Reserved.
3:0	<p>DRAM Idle Timer (DIT). This field determines the number of clocks that the DRAM controller will remain in the idle state before precharging all pages. This field is used for both EDO and SDRAM memory systems.</p> <p>0000 = 0 clocks 0001 = 2 clocks 0010 = 4 clocks 0011 = 8 clocks 0100 = 10 clocks 0101 = 12 clocks 0110 = 16 clocks 0111 = 32 clocks 1XXX = Infinite (pages are not closed for idle condition).</p>

3.3.26 PMCR—Power Management Control Register (Device 0)

Address Offset: 7Ah
 Default Value: 0000_S0S0b
 Access: Read/Write
 Size: 8 Bits

Bit	Description
7	Power Down SDRAM Enable (PDSE). 1 = Enable. When PDSE=1, an SDRAM row in idle state will be issued a power down command. The SDRAM row will exit power down mode only when there is a request to access this particular row. 0 = Disable
6	ACPI Control Register Enable (SCRE). 1 = Enable. The ACPI control register in the 82443BX is enabled, and all CPU cycles to IO address 0022h are handled by the 82443BX and are not forwarded to PCI. 0 = Disable (default). All CPU cycles to IO address 0022h are passed on to the PCI bus.
5	Suspend Refresh Type (SRT). This bit determines what type of EDO DRAM refresh is used during Power On Suspend (POS/STR) or Suspend to RAM modes. SRT has no effect on SDRAM refresh. 1 = Self refresh mode 0 = CBR fresh mode NOTE: When PCIRST# assertion occurs during POS/STR, this bit is not reset to '0'.
4	Normal Refresh Enable (NREF_EN). This bit is used to enable normal refresh operation following a POS/STR state. After coming out of reset the software must set this bit before doing an access to memory. 1 = Enable 0 = Disable
3	Quick Start Mode (QSTART) (RO). 1 = Quick start mode of operation is enabled for the processor. This mode is entered using a strapping option that is sampled by the 82443BX and the CPU during reset. This register bit is Read Only and a configuration write to it is ignored.
2	Gated Clock Enable (GCLKEN). GCLKEN enables internal dynamic clock gating in the 82443BX when a AGPset "IDLE" state occurs. This happens when the 82443BX detects an idle state on all its buses. 1 = Enable 0 = Disable
1	AGP Disable (AGP_DIS). This register bit is Read Only and a configuration write to it is ignored. 1 = Disable. The AGP interface and the clocks of AGP associated logic are permanently disabled. This mode is entered using a strapping option that is sampled by the 82443BX during reset. 0 = Enable
0	CPU reset without PCIRST enable (CRst_En). This bit enables the 82443BX to assert CPU reset without an incoming PCIRST#. This option allows the reset of the processor when the system is coming out of POS state. Defaults to '0' upon PCIRST# assertion. 1 = Enable 0 = Disable NOTE: When PCIRST# assertion occurs during POS/STR, this bit is not reset to '0'.

3.3.27 SCRR—Suspend CBR Refresh Rate Register (Device 0)

Address Offset: 7Bh–7Ch
 Default Value: 0038h
 Access: Read/Write
 Size: 16 Bits

Bit	Description
15:13	Reserved.
12	<p>Suspend CBR refresh Rate Auto Adjust Enable (SRRAEN). SRRAEN bit is cleared to its default during cold reset only. It is not affected by PCIRST# during resume from suspend.</p> <p>0 = Disable (default). Indicates that the suspend CBR refresh rate is not updated by the 82443BX hardware to track the system operating conditions. In this case, it is expected that BIOS will set the SRR to reflect the worst case operating conditions so that minimum refresh rate will be provided.</p> <p>1 = Enable. Indicates that the 82443BX hardware adjusts the suspend refresh rate according to system operating conditions by comparing the number of OSCCLKs in a given time. This mode allows the system to dynamically adjust the refresh rate and thus minimize suspend power consumption while guaranteeing required refresh rate.</p>
11:0	<p>Suspend CBR Refresh Rate (SRR). The rate is loaded into the counter which counts down on OSCCLK rising edges. When it expires, a suspend CBR refresh request is triggered. This bit field may be loaded by BIOS to reflect the desirable refresh rate. In addition, the 82443BX will update it automatically, when the above SRRAEN = 1. In either case, the register is accessible for read and write operation at all times.</p> <ul style="list-style-type: none"> This 12-bit field provides a dynamic range greater than the maximum CBR refresh rate that is supported of 249.6uSEC. SRR bit field is cleared to its default during cold reset only. It is not affected by PCIRST# during resume from suspend. The default value of this register is 038h, or 56 decimal. It represents a 15.5uS time between refreshes with the slowest corner OSCCLK cycle time of 270nS.

3.3.28 EAP—Error Address Pointer Register (Device 0)

Address Offset: 80–83h
 Default Value: 00000000h
 Access: Read Only, Read/Write-Clear
 Size: 32 Bits

Bit	Description
31:12	Error Address Pointer (EAP) (RO). This field is used to store the 4 KB block of main memory of which an error (single bit or multi-bit error) has occurred. Note that this field represents the address of the first error occurrence after bits 1:0 have been cleared by software. Once bits 1:0 are set to a value different than 00b, as a result of an error, this bit field is locked and doesn't change as a result of a new error.
11:2	Reserved.
1	Multiple Bit Error (MBE) (R/WC). This bit indicates that a multi-bit ECC error has occurred, and the address has been logged in bits 31:12. The EAP register is locked until the CPU clears this bit by writing a 1. Software uses bits 1:0 to detect whether the logged error address is for Single or Multi bit error, since both Single and Multiple Error bits of the Error Status register can be set. Once software completes the error processing, a value of '1' is written to this bit field to clear the value (back to 0) and unlock the error logging mechanism. Note: Any ECC errors received during initialization should be ignored.
0	Single Bit Error (SBE) (R/WC). 1 = Indicates that a single bit ECC error has occurred, and the address has been logged in bits 31:12. The EAP register is locked until the CPU clears this bit by writing a 1. Note: Any ECC errors received during initialization should be ignored.

3.3.29 ERRCMD—Error Command Register (Device 0)

Address Offset: 90h
 Default Value: 80h
 Access: Read/Write
 Size: 8 bits

This 8-bit register controls the 82443BX responses to various system errors. The actual assertion of SERR# is enabled via the PCI Command register.

Bit	Description
7	SERR# on AGP Non-Snoopable Access Outside of Graphics Aperture. When enabled and bit 10 of ERRSTS registers transitions from 0 to 1 (during an AGP access to the address outside of the graphics aperture) then an SERR# assertion event will be generated. 1 = Enable (default). 0 = Disable.
6	SERR# on Invalid AGP DRAM Access. AGP non-snoopable READ accesses to locations outside the graphics aperture and outside the main DRAM range (i.e., in 640 KB – 1 MB range or above top of memory) are invalid. When this bit is set, bit 9 of the ERRSTS will be set and SERR# will be asserted, read accesses are not directed to main memory or the aperture range. 1 = Enable. 0 = Disable reporting of this condition via SERR#.
5	SERR# on Access to Invalid Graphics Aperture Translation Table Entry. When enabled, the 82443BX sets bit 8 of the ERRSTS and asserts SERR# following a read or write access to an invalid entry in the Graphics Aperture Translation Table residing in main memory. 1 = Enable. 0 = Disable reporting of this condition via SERR#.
4	SERR# on Receiving Target Abort. 1 = Enable. The 82443BX asserts SERR# on receiving a target abort on either the PCI or AGP. 0 = Disable. The 82443BX does not assert SERR# on receipt of a target abort.
3	SERR# on Detected Thermal Throttling Condition. 1 = Enable. The 82443BX asserts SERR# when thermal throttling condition is detected for either the read or the write function. 0 = The 82443BX does not assert SERR# for thermal throttling.
2	SERR# Assertion Mode. 1 = SERR# is a level mode signal. Systems that connect SERR# to EXTSMI# for error reporting should set this bit to 1. 0 = SERR# is asserted for 1 PCI clock (normal PCI mode). (default)
1	SERR# on Receiving Multiple-Bit ECC/Parity Error. When enabled, the 82443BX asserts SERR# when it detects a multiple-bit error reported by the DRAM controller. For systems not supporting ECC this bit must be disabled. 1 = Enable. 0 = Disable. Note: Any ECC errors received during initialization should be ignored.
0	SERR# on Receiving Single-bit ECC Error. When enabled, the 82443BX asserts SERR# when it detects a single-bit ECC error. For systems not supporting ECC, this bit must be disabled. 1 = Enable. 0 = Disable. Note: Any ECC errors received during initialization should be ignored.

3.3.30 ERRSTS—Error Status Register (Device 0)

Address Offset: 91–92h
 Default Value: 0000h
 Access: Read Only, Read/Write Clear
 Size: 16 bits

This 16-bit register is used to report error conditions via the SERR# mechanism. SERR# is generated on a zero to one transition of any of these flags (if enabled by the ERRCMD register).

Bit	Description
15:13	Reserved.
12	Read thermal Throttling Condition. 1 = Read thermal throttling condition occurred. 0 = Software writes “1” to clear this bit. Default=0
11	Write Thermal Throttling Condition. 1 = Write thermal throttling condition occurred. 0 = Software writes “1” to clear this bit. Default=0
10	AGP non-snoopable access outside of Graphics Aperture. 1 = AGP access occurred to the address that is outside of the graphics aperture range. 0 = Software writes “1” to clear this bit. Default=0
9	Invalid AGP non-snoopable DRAM read access (R/WC). 1 = AGP non-snoopable READ access was attempted outside of the graphics aperture and outside of main memory (i.e., in 640 KB – 1 MB range or above top of memory). 0 = Software must write a “1” to clear this status bit.
8	Access to Invalid Graphics Aperture Translation Table Entry (AIGATT) (R/WC). 1 = An invalid translation table entry was returned in response to a graphics aperture read or write access. 0 = Software must write a “1” to clear this bit.
7:5	Multi-bit First Error (MBFRE) (RO). This field contains the encoded value of the DRAM row in which the first multi-bit error occurred. A simple binary encoding is used to indicate the row containing the multi-bit error. When an error is detected, this field is updated and the MEF bit is set. This field will then be locked (no further updates) until the MEF flag has been reset. If MEF is 0, the value in this field is undefined. 000 = Row 0 001 = Row 1 ... 111 = Row 7
4	Multiple-bit ECC (uncorrectable) Error Flag (MEF) (R/WC). 1 = Memory data transfer had an uncorrectable error (i.e., multiple-bit error). When enabled, a multiple bit error is reported by the DRAM controller and propagated to the SERR# pin, if enabled by bit 1 in the ERRCMD register. 0 = BIOS writes a 1 to clear this bit and unlock the MBFRE field. (Default = 0).
3:1	Single-bit First Row Error (SBFRE) (RO). This field contains the encoded value of the DRAM row in which the first single-bit error occurred. A simple binary encoding is used to indicate the row containing the single-bit error. When an error is detected, this field is updated and SEF is set. This field is then locked (no further updates) until the SEF flag has been reset. If SEF is 0, the value in this field is undefined. 000 = Row 0 001 = Row 1 ... 111 = Row 7
0	Single-bit (correctable) ECC Error Flag (SEF) (R/WC). 1 = Memory data transfer had a single-bit correctable error and the corrected data was sent for the access. When ECC is enabled, a single bit error is reported and propagated to the SERR# pin, if enabled by bit 0 in the ERRCMD register. 0 = BIOS writes a 1 to clear this bit and unlock the SBFRE field.

3.3.31 ACAPID—AGP Capability Identifier Register (Device 0)

Address Offset: A0–A3h
 Default Value: 00100002h/00000000h
 Access: Read Only
 Size: 32 bits

This register provides normal identifier for AGP capability.

Bit	Description
31:24	Reserved
23:20	Major AGP Revision Number. This field provides a major revision number of AGP specification to which this version of the 82443BX conforms. When the AGP DIS bit (PMCR[1]) is set to 0, this number is set to value of “0001b” (i.e., implying Rev 1.x). When the AGP DIS bit (PMCR[1]) is set to 1, This number is set to “0000b”.
19:16	Minor AGP Revision Number. These bits provide a minor revision number of AGP specification to which this version of 82443BX conforms. This number is hardwired to value of “0000” (i.e., implying Rev x.0). Together with major revision number this field identifies 82443BX as an AGP REV 1.0 compliant device.
15:8	Next Capability Pointer. AGP capability is the first and the last capability described via the capability pointer mechanism. 0s = Hardwired to 0s to indicate the end of the capability linked list.
7:0	AGP Capability ID. This field identifies the linked list item as containing AGP registers. When the AGP DIS bit (PMCR[1]) is set to 0, this field has a value of 0000_0010b assigned by the PCI SIG. When the AGP DIS bit (PMCR[1]) is set to 1, this field has a value of 00h.

3.3.32 AGPSTAT—AGP Status Register (Device 0)

Address Offset: A4–A7h
 Default Value: 1F000203h
 Access: Read Only
 Size: 32 bits

This register reports AGP compliant device capability/status.

Bit	Description
31:24	AGP Maximum Request Queue Depth (RO). This field is hardwired to 1Fh to indicate a maximum of 32 outstanding AGP command requests can be handled by the 82443BX.
23:10	Reserved
9	AGP Side Band Addressing Supported. This bit indicates that the 82443BX supports side band addressing. It is hardwired to 1.
8:2	Reserved
1:0	AGP Data Transfer Type Supported (R/W). Bit 0 identifies if AGP compliant device supports 1x data transfer mode and bit 1 identifies if AGP compliant device supports 2x data transfer mode. Configuration software will update this field by setting only one bit that corresponds to the capability of AGP master (after that capability has been verified by accessing the same functional register within the AGP masters configuration space). 00 = Not allowed 01 = 1x data transfer mode supported 10 = 2x data transfer mode supported 11 = (default) NOTE: The selected data transfer mode apply to both AD bus and SBA bus.

3.3.33 AGPCMD—AGP Command Register (Device 0)

Address Offset: A8–ABh
 Default Value: 00000000h
 Access: Read/Write
 Size: 32 bits

This register provides control of the AGP operational parameters.

Bit	Description
31:10	Reserved.
9	AGP Side Band Enable. This bit enables the side band addressing mechanism. 1 = Enable. 0 = Disable.
8	AGP Enable. When disabled, the 82443BX ignores all AGP operations, including the sync cycle. Any AGP operations received while this bit is set to 1 is serviced even if this bit is reset to 0. If this bit transitions from a 1 to a 0 on a clock edge in the middle of an SBA command being delivered in 1X mode the command will be issued. When this bit is set to 1 the 82443BX will respond to AGP operations delivered via PIPE#, or to operations delivered via SBA if the AGP Side Band Enable bit is also set to 1. The AGP parameters in the AGPCMD and AGPCTRL registers must be set prior to setting this bit '1'. With the exception of the GTLB_ENABLE (bit 7, AGPCTRL), and ATTBASE register (offset B8h), which can be modified dynamically. 1 = Enable. 0 = Disable.
7:2	Reserved.
1:0	AGP Data Transfer Rate. One (and only one) bit in this field must be set to indicate the desired data transfer rate (Bit 0 for 1X, Bit 1 for 2X). The same bit must be set on both master and target. Configuration software will update this field by setting only one bit that corresponds to the capability of AGP master (after that capability has been verified by accessing the same functional register within the AGP masters configuration space.) 00 = default 01 = 1x data transfer rate. 10 = 2x data transfer rate. 11 = Illegal NOTE: This field applies to AD and SBA buses.

3.3.34 AGPCTRL—AGP Control Register (Device 0)

Address Offset: B0–B3h
 Default Value: 00000000h
 Access: Read/Write
 Size: 32 bits

This register provides for additional control of the AGP interface.

Bit	Description															
31:16	Reserved.															
15	<p>Snoopable Writes In Order With AGP Reads Disable (AGPDCD). When set to 0 (default), the 82443BX maintains ordering between snoopable write cycles and AGP reads. When set to 1, the 82443BX handles the AGP reads and snoopable writes as independent streams.</p> <table border="1"> <thead> <tr> <th>AGPDCD (Bit 15)</th> <th>AGPRSE (Bit 13)</th> <th>Description</th> </tr> </thead> <tbody> <tr> <td>0</td> <td>0</td> <td>DWB is visible to AGP reads. DWB flushes only when address hit.</td> </tr> <tr> <td>0</td> <td>1</td> <td>Illegal.</td> </tr> <tr> <td>1</td> <td>0</td> <td>Illegal</td> </tr> <tr> <td>1</td> <td>1</td> <td>DWB flushes when write to AGP occurs</td> </tr> </tbody> </table>	AGPDCD (Bit 15)	AGPRSE (Bit 13)	Description	0	0	DWB is visible to AGP reads. DWB flushes only when address hit.	0	1	Illegal.	1	0	Illegal	1	1	DWB flushes when write to AGP occurs
AGPDCD (Bit 15)	AGPRSE (Bit 13)	Description														
0	0	DWB is visible to AGP reads. DWB flushes only when address hit.														
0	1	Illegal.														
1	0	Illegal														
1	1	DWB flushes when write to AGP occurs														
14	Reserved															
13	<p>Graphics Aperture Write-AGP Read Synchronization Enable (AGPRSE). When this bit is set the 82443BX will ensure that all writes posted in the Global Write Buffer to the Graphics Aperture are retired to DRAM before the 82443BX will initiate any CPU-to-AGP cycle. This can be used to ensure synchronization between the CPU and AGP master. The AGPDCD bit description defines the interaction between the AGPRSE bit and the AGPDCD bit.</p> <p>1 = Enable 0 = Disable (Default)</p>															
12:8	Reserved															
7	<p>GTLB Enable (and GTLB Flush Control).</p> <p>1 = Enable. Normal operations of the Graphics Translation Lookaside Buffer. 0 = Disable (default). The GTLB is flushed by clearing the valid bits associated with each entry.</p>															
6:0	Reserved.															

3.3.35 APSIZE—Aperture Size Register (Device 0)

Address Offset: B4h
 Default Value: 00h
 Access: Read/Write
 Size: 8 bits

This register determines the effective size of the Graphics Aperture used for a particular 82443BX configuration. This register can be updated by the 82443BX-specific BIOS configuration sequence before the PCI normal bus enumeration sequence takes place. If the register is not updated, a default value selects an aperture of maximum size (i.e., 256 MB). The size of the table that will correspond to a 256 MB aperture is not practical for most applications and, therefore, these bits must be programmed to a smaller practical value that forces adequate address range to be requested via the APBASE register from the PCI configuration software.

Bit	Description
7:6	Reserved.
5:0	<p>Graphics Aperture Size (APSIZE) (R/W). Each bit in APSIZE[5:0] operates on similarly ordered bits in APBASE[27:22] of the Aperture Base configuration register. When a particular bit of this field is “0”, it forces the similarly ordered bit in APBASE[27:22] to behave as “hardwired” to 0. When a particular bit of this field is set to “1”, it allows corresponding bit of the APBASE[27:22] to be read/write accessible. Only the following combinations are allowed:</p> <p> 11 1111 = 4 MB 11 1110 = 8 MB 11 1100 = 16 MB 11 1000 = 32 MB 11 0000 = 64 MB 10 0000 = 128 MB 00 0000 = 256MB </p> <p>Default for APSIZE[5:0]=000000b forces default APBASE[27:22] =000000b (i.e., all bits respond as “hardwired” to 0). This provides maximum aperture size of 256 MB. As another example, programming APSIZE[5:0]=111000b hardwires APBASE[24:22]=000b and while enabling APBASE[27:25] as read/write programmable.</p>

3.3.36 ATTBASE—Aperture Translation Table Base Register (Device 0)

Address Offset: B8–BBh
 Default Value: 00000000h
 Access: Read/Write
 Size: 32 bits

This register provides the starting address of the Graphics Aperture Translation Table base located in the main DRAM. The ATTBASE register may be dynamically changed.

Note: The address provided via ATTBASE is 4KB aligned.

Bit	Description
31:12	Aperture Translation Table Base Address. Bits 31:12 correspond to address bits 31:12, respectively. This field contains a pointer to the base of the translation table used to map memory space addresses in the aperture range to addresses in main memory.
11:0	Reserved.

3.3.37 MBFS—Memory Buffer Frequency Select Register (Device 0)

Address Offset: CA–CCh
 Default Value: 000000h
 Access: Read/Write
 Size: 24 bits

The settings in this register enable the 100 MHz or 66 MHz buffers for each of the following signal groups.

Note: The choice of 100 MHz or 66 MHz buffer is independent of bus frequency. It is possible to select a 100 MHz memory buffer even though the bus frequency is 66 MHz (and vice versa).

Bit	Description
23	Reserved
22	MAA[13:0], WEA#, SRASA#, SCASA# (100 MHz/66 MHz buffer select bit). This bit enables either 100 MHz or 66 MHz buffers for MAA[13:0], WEA#, SRASA#, SCASA#. 0 = 66 MHz 1 = 100 MHz
21	MAB[12:11, 9:0]# & MAB[13,10], WEB#, SRASB#, SCASB# (100 MHz/66 MHz buffer select bit). This bit enables either 100 MHz or 66 MHz buffers for MAB[12:11, 9:0]# & MAB[13,10], WEB#, SRASB#, SCASB#. Note that the address's MABx# are inverted copies of MAA, with the exception of MAB[13,10]. 0 = 66 MHz 1 = 100 MHz
20	MD [63:0] (100 MHz/66 MHz buffer select bit [Control 2]). This bit enables either 100 MHz or 66 MHz buffers for MD [63:0] [Control 2]. (Refer to the corresponding MBSC register for programming details). 0 = 66 MHz 1 = 100 MHz
19	MD [63:0] (100 MHz/66 MHz buffer select bit [Control 1]). This bit enables either 100 MHz or 66 MHz buffers for MD [63:0] [Control 1]. (Refer to the corresponding MBSC register for programming details). 0 = 66 MHz 1 = 100 MHz
18	MECC [7:0] (100 MHz/66 MHz buffer select bit [Control 2]). This bit enables either 100 MHz or 66 MHz buffers for MECC [7:0] [Control 2]. (Refer to the corresponding MBSC register for programming details). 0 = 66 MHz 1 = 100 MHz
17	MECC [7:0] (100 MHz/66 MHz buffer select bit [Control 1]). This bit enables either 100 MHz or 66 MHz buffers for MECC [7:0] [Control 1]. (Refer to the corresponding MBSC register for programming details). 0 = 66 MHz 1 = 100 MHz
16	CSB7#/CKE5 (100 MHz/66 MHz buffer select bit). This bit enables either 100 MHz or 66 MHz buffers for CSB7#/CKE5. 0 = 66 MHz 1 = 100 MHz

Bit	Description
15	CSA7#/CKE3 (100 MHz/66 MHz buffer select bit). This bit enables either 100 MHz or 66 MHz buffers for CSA7#/CKE3. 0 = 66 MHz 1 = 100 MHz
14	CSB6#/CKE4 (100 MHz/66 MHz buffer select bit). This bit enables either 100 MHz or 66 MHz buffers for CSB6#/CKE4. 0 = 66 MHz 1 = 100 MHz
13	CSA6#/CKE2 (100 MHz/66 MHz buffer select bit). This bit enables either 100 MHz or 66 MHz buffers for CSA6#/CKE2. 0 = 66 MHz 1 = 100 MHz
12	CSA5#/RASA5#, CSB5#/RASB5# (100 MHz/66 MHz buffer select bit). This bit enables either 100 MHz or 66 MHz buffers for CSA5#/RASA5#, CSB5#/RASB5#. 0 = 66 MHz 1 = 100 MHz
11	CSA4#/RASA4#, CSB4#/RASB4# (100 MHz/66 MHz buffer select bit). This bit enables either 100 MHz or 66 MHz buffers for CSA4#/RASA4#, CSB4#/RASB4#. 0 = 66 MHz 1 = 100 MHz
10	CSA3#/RASA3#, CSB3#/RASB3# (100 MHz/66 MHz buffer select bit). This bit enables either 100 MHz or 66 MHz buffers for CSA3#/RASA3#, CSB3#/RASB3#. 0 = 66 MHz 1 = 100 MHz
9	CSA2#/RASA2#, CSB2#/RASB2# (100 MHz/66 MHz buffer select bit). This bit enables either 100 MHz or 66 MHz buffers for CSA2#/RASA2#, CSB2#/RASB2#. 0 = 66 MHz 1 = 100 MHz
8	CSA1#/RASA1#, CSB1#/RASB1# (100 MHz/66 MHz buffer select bit). This bit enables either 100 MHz or 66 MHz buffers for CSA1#/RASA1#, CSB1#/RASB1#. 0 = 66 MHz 1 = 100 MHz
7	CSA0#/RASA0#, CSB0#/RASB0# (100 MHz/66 MHz buffer select bit). This bit enables either 100 MHz or 66 MHz buffers for CSA0#/RASA0#, CSB0#/RASB0#. 0 = 66 MHz 1 = 100 MHz
6	DQMA5/CASA5# (100 MHz/66 MHz buffer select bit). This bit enables either 100 MHz or 66 MHz buffers for DQMA5/CASA5#. 0 = 66 MHz 1 = 100 MHz
5	DQMA1/CASA1# (100 MHz/66 MHz buffer select bit). This bit enables either 100 MHz or 66 MHz buffers for DQMA1/CASA1#. 0 = 66 MHz 1 = 100 MHz
4	DQMB5/CASB5# (100 MHz/66 MHz buffer select bit). This bit enables either 100 MHz or 66 MHz buffers for DQMB5/CASB5#. 0 = 66 MHz 1 = 100 MHz

Bit	Description
3	DQMB1/CASB1# (100 MHz/66 MHz buffer select bit). This bit enables either 100 MHz or 66 MHz buffers for DQMB1/CASB1#. 0 = 66 MHz 1 = 100 MHz
2	DQMA[7:6,4:2,0]/CASA[7:6,4:2,0]# (100 MHz/66 MHz buffer select bit). This bit enables either 100 MHz or 66 MHz buffers for DQMA[7:6]/CASA[7:6]#, DQMA[4:2]/CASA[4:2]#, and the DQMA[0]/CASA[0]#. 0 = 66 MHz 1 = 100 MHz
1	CKE1/GCKE (100 MHz/66 MHz buffer select bit). This bit enables either 100 MHz or 66 MHz buffers forCKE1. 0 = 66 MHz 1 = 100 MHz
0	CKE0/FENA (100 MHz/66 MHz buffer select bit). This bit enables either 100 MHz or 66 MHz buffers for CKE0/FENA. 0 = 66 MHz 1 = 100 MHz

3.3.38 BSPAD—BIOS Scratch Pad Register (Device 0)

Address Offset: D0–D7h
 Default Value: 0000-0000-0000-0000h
 Access: Read/Write
 Size: 64 bits

This register provides 8 bytes general purpose read/write registers for the BIOS to perform the configuration routine. The 82443BX will provide this 8 byte register in the PCI configuration space of the 82443BX device0 on bus 0. The registers in this range will be defined as read/write and will be initialized to all 0's after PCIRST#. The BIOS will can access these registers through the normal PCI configuration register mechanism, accessing 1,2 or 4 bytes in every data access.

Bit	Description
64:0	BIOS Work Space.

3.3.39 DWTC—DRAM Write Thermal Throttling Control Register (Device 0)

Offset: E0h–E7h
 Default: 0000_0000_0000_0000h
 Access: Read/Write/Lock
 Size: 64 bits

A locking mechanism is included to protect contents of this register as well as the DRAM Read Thermal Throttling Control register described below.

Bits	Description
63	Throttle Lock (TLOCK). This bit secures the DRAM thermal throttling control registers. 1 = All configuration register bits in E0h–E7h and E8h–EFh (read throttle control) become read-only. 0 = Default
62:46	Reserved
45:38	Global DRAM Write Sampling Window (GDWSW). This 8-bit value is multiplied by 4 to define the length of time in milliseconds (0–1020) over which the number of QWords written is counted.
37:26	Global QWord Threshold (GQT). The 12-bit value held in this field is multiplied by 215 to arrive at the number of QWords that must be written within the Global DRAM Write Sampling Window in order to cause the thermal throttling mechanism to be invoked.
25:20	Throttle Time (TT). This value provides a multiplier between 0 and 63 which specifies how long thermal throttling remains in effect as a number of Global DRAM Write Sampling Windows. For example, if GDWSW is programmed to 1000_0000b and TT is set to 01_0000b, then thermal throttling will be performed for ~2 seconds once invoked (128 ms * 16).
19:13	Throttle Monitoring Window (TMW). The value in this register is padded with four 0's to specify a window of 0–2047 DRAM CLKs with 16 clock granularity. While the thermal throttling mechanism is invoked, DRAM writes are monitored during this window—if the number of QWords written during the window reaches the Throttle QWord Maximum, then write requests are blocked for the remainder of the window.
12:3	Throttle QWord Maximum (TQM). The Throttle QWord Maximum defines the maximum number of QWords between 0–1023 which are permitted to be written to DRAM within one Throttle Monitoring Window while the thermal throttling mechanism is in effect.
2:0	DRAM Write Throttle Mode. Normal DRAM write monitoring and thermal throttling operation are enabled when bits 2:0 are set to 100. All other combinations are Intel Reserved. 000-011 = Intel Reserved 100 = Normal Operations 101-111 = Intel Reserved

3.3.40 DRTC—DRAM Read Thermal Throttling Control Register (Device 0)

Offset: E8h–EFh
 Default: 0000_0000_0000_0000h
 Access: Read/Write/Lock
 Size: 64 Bits

The contents of this register are protected by making the bits read-only once a ‘1’ is written to the Throttle Lock bit (bit 63 of configuration register E0–E7h)

Bits	Description
63:46	Reserved
45:38	Global DRAM Read Sampling Window (GDRSW). This 8-bit value is multiplied by 4 to define the length of time in milliseconds (0–1020) over which the number of QWords read from DRAM is counted.
37:26	Global Read QWord Threshold (GRQT). The 12-bit value held in this field is multiplied by 215 to arrive at the number of QWords that must be written within the Global DRAM Read Sampling Window in order to cause the thermal throttling mechanism to be invoked.
25:20	Read Throttle Time (RTT). This value provides a multiplier between 0 and 63 which specifies how long read thermal throttling remains in effect as a number of Global DRAM Read Sampling Windows. For example, if GDRSW is programmed to 1000_0000b and RTT is set to 01_0000b, then read thermal throttling will be performed for ~2 seconds once invoked (128 ms * 16).
19:13	Read Throttle Monitoring Window (RTMW). The value in this register is padded with 4 0's to specify a window of 0–2047 DRAM CLKs with 16 clock granularity. While the thermal throttling mechanism is invoked, DRAM reads are monitored during this window—if the number of QWords read during the window reaches the Throttle QWord Maximum, then Host and PCI read requests, as well as all AGP requests, are blocked for the remainder of the window.
12:3	Read Throttle QWord Maximum (RTQM). The Read Throttle QWord Maximum defines the maximum number of QWords between 0–1023 which are permitted to be read from DRAM within one Read Throttle Monitoring Window while thermal throttling mechanism is in effect.
2:0	DRAM Read Throttle Mode. Normal DRAM read monitoring and thermal throttling operation are enabled when bits 2:0 are set to 100. All other combinations are Intel Reserved. 000-011 = Intel Reserved 100 = Normal Operations 101-111 = Intel Reserved

3.3.41 BUFFC—Buffer Control Register (Device 0)

Offset: F0–F1h
 Default: 0000h
 Access: Read/Write
 Size: 16 bits

The Jam Latch design provides the AGP sub-system with a variable strength, to better accommodate the clamping requirements.

The Jam Latch Register should be enabled by the BIOS during the resume sequence from STR, if these Jam Latch control bits had been enabled before the STR was executed.

Bit	Description
15:10	Reserved.
9:6	AGP Jam Latch Strength Select. Bit 9 = 1; Enable strong pull-up Bit 8 = 1; Enable weak pull-up Bit 7 = 1; Enable strong pull-down Bit 6 = 1; Enable weak pull-down
5:0	Intel Reserved.

3.4 PCI-to-PCI Bridge Registers (Device 1)

The configuration space for device #1 is controlled by the AGP_DIS bit in the PMCR register.

Note: When AGP_DIS = 0, the configuration space for device #1 is enabled, and the registers defined below are accessible through the configuration mechanism defined in the first section of this document.

Note: When the AGP_DIS = 1, the configuration space for device #1 is disabled. All configuration cycles (reads and writes) to device #1 of bus 0 will cause the master abort status bit for device #0/ bus 0 to be set. Configuration read cycles will return data of all 1's. Configuration write cycles will have no effect on the registers.

Table 3-4. 82443BX Configuration Space—Device 1

Address Offset	Register Symbol	Register Name	Default Value	Access
00–01h	VID1	Vendor Identification	8086h	RO
02–03h	DID1	Device Identification	7191h	RO
04–05h	PCICMD1	PCI Command Register	0000h	R/W
06–07h	PCISTS1	PCI Status Register	0220h	RO, R/WC
08h	RID1	Revision Identification	00/01h	RO
09h	—	Reserved	00h	—
0Ah	SUBC1	Sub-Class Code	04h	RO
0Bh	BCC1	Base Class Code	06h	RO
0Ch	—	Reserved	00h	—
0Dh	MLT1	Master Latency Timer	00h	R/W
0Eh	HDR1	Header Type	01h	RO
0F–17h	—	Reserved	00h	—
18h	PBUSN	Primary Bus Number	00h	RO
19h	SBUSN	Secondary Bus Number	00h	R/W
1Ah	SUBUSN	Subordinate Bus Number	00h	R/W
1Bh	SMLT	Secondary Bus Master Latency Timer	00h	R/W
1Ch	IOBASE	I/O Base Address Register	F0h	R/W
1Dh	IOLIMIT	I/O Limit Address Register	00h	R/W
1E–1Fh	SSTS	Secondary PCI-to-PCI Status Register	02A0h	R/WC, RO
20–21h	MBASE	Memory Base Address Register	FFF0h	R/W
22–23h	MLIMIT	Memory Limit Address Register	0000h	R/W
24–25h	PMBASE	Prefetchable Memory Base Address Reg.	FFF0h	R/W
26–27h	PMLIMIT	Prefetchable Memory Limit Address Reg.	0000h	R/W
28–3Dh	—	Reserved	0	c
3Eh	BCTRL	Bridge Control Register	80h	R/W
3F–FFh	—	Reserved	00h	—

3.4.1 VID1—Vendor Identification Register (Device 1)

Address Offset: 00–01h
 Default Value: 8086h
 Attribute: Read Only
 Size: 16 bits

The VID Register contains the vendor identification number. This 16-bit register combined with the Device Identification Register uniquely identify any PCI device. Writes to this register have no effect.

Bit	Description
15:0	Vendor Identification Number. This is a 16-bit value assigned to Intel. Intel VID = 8086h.

3.4.2 DID1—Device Identification Register (Device 1)

Address Offset: 02–03h
 Default Value: 7191h
 Attribute: Read Only
 Size: 16 bits

This 16-bit register combined with the Vendor Identification register uniquely identifies any PCI device. Writes to this register have no effect.

Bit	Description
15:0	Device Identification Number. This is a 16 bit value assigned to the 82443BX device #1. 82443BX device #1 DID =7191h.

3.4.3 PCICMD1—PCI-to-PCI Command Register (Device 1)

Address Offset: 04–05h
 Default: 0000h
 Access: Read/Write
 Size 16 bits

Bit	Descriptions
15:10	Reserved.
9	Fast Back-to-Back: Not Applicable. Hardwired to 0.
8	SERR# Enable (SERRE1). When enabled the SERR# signal driver (common for PCI and AGP) is enabled for error conditions that occur on AGP. If both SERRE and SERRE1 are reset to 0, then SERR# is never driven by the 82443BX. Also, if this bit is set and the Parity Error Response Enable Bit (Dev 01h, Register 3Eh, Bit 0) is set, then the 82443BX will report ADDRESS and DATA parity errors on AGP. 1 = Enable. 0 = Disable.
7	Address/Data Stepping. Not applicable. Hardwired to 0.
6	Parity Error Enable (PERRE1). Hardwired to 0.
5	Reserved.
4	Memory Write and Invalidate Enable: Not applicable. However, supported as a read/write bit to avoid the problems with normal PCI-to-PCI Bridge configuration software.
3	Special Cycle Enable: Not applicable. However, supported as a read/write bit to avoid the problems with normal PCI-to-PCI Bridge configuration software.
2	Bus Master Enable (BME1): Not applicable. However, supported as a read/write bit to avoid the problems with normal PCI-to-PCI Bridge configuration software.
1	Memory Access Enable (MAE1): Not applicable. However, supported as a read/write bit to avoid the problems with normal PCI-to-PCI Bridge configuration software.
0	I/O Access Enable (IOAE1): Not applicable. However, supported as a read/write bit to avoid the problems with normal PCI-to-PCI Bridge configuration software.

3.4.4 PCISTS1—PCI-to-PCI Status Register (Device 1)

Address Offset: 06–07h
 Default Value: 0220h
 Access: Read Only, Read/Write Clear
 Size: 16 bits

PCISTS1 is a 16-bit status register that reports the occurrence of error conditions associated with primary side of the “virtual” PCI-to-PCI bridge embedded within the 82443BX.

Bit	Descriptions
15	Detected Parity Error (DPE1). Not Applicable. Hardwired to 0.
14	Reserved.
13	Received Master Abort Status (RMAS1). Not Applicable. Hardwired to 0.
12	Received Target Abort Status (RTAS1). Not Applicable. Hardwired to 0.
11	Signaled Target Abort Status (STAS1). Not Applicable. Hardwired to 0.
10:9	DEVSEL# Timing (DEVT1). Not Applicable. Hardwired to “01b”.
8	Data Parity Detected (DPD1). Not Applicable. Hardwired to 0.
7	Fast Back-to-Back (FB2B1). Not Applicable. Hardwired to 0.
6	Reserved.
5	66/60 MHz Capability. Hardwired to “1”.
4:0	Reserved.

3.4.5 RID1—Revision Identification Register (Device 1)

Address Offset: 08h
 Default Value: 00/01h
 Access: Read Only
 Size: 8 bits

This register contains the revision number of the 82443BX device #1. These bits are read only and writes to this register have no effect. For the A-0 Stepping, this value is 00h.

Bit	Description
7:0	Revision Identification Number. This is an 8-bit value that indicates the revision identification number for the 82443BX device #1. 02h = B1 stepping

3.4.6 SUBC1—Sub-Class Code Register (Device 1)

Address Offset: 0Ah
 Default Value: 04h
 Access: Read Only
 Size: 8 bits

This register contains the Sub-Class Code for the 82443BX device #1. This code is 04h indicating a PCI-to-PCI Bridge device. The register is read only.

Bit	Description
7:0	Sub-Class Code (SUBC1). This is an 8-bit value that indicates the category of Bridge into which the 82443BX falls. 04h = Host Bridge.

3.4.7 BCC1—Base Class Code Register (Device 1)

Address Offset: 0Bh
 Default Value: 06h
 Access: Read Only
 Size: 8 bits

This register contains the Base Class Code of the 82443BX device #1. This code is 06h indicating a Bridge device. This register is read only.

Bit	Description
7:0	Base Class Code (BASCC). This is an 8-bit value that indicates the Base Class Code for the 82443BX device #1. 06h = Bridge device.

3.4.8 MLT1—Master Latency Timer Register (Device 1)

Address Offset: 0Dh
 Default Value: 00h
 Access: Read/Write
 Size: 8 bits

This functionality is not applicable. It is described here since these bits should be implemented as a read/write to comply with the normal PCI-to-PCI bridge configuration software.

Bit	Description
7:3	Not applicable but support read/write operations. (Reads return previously written data.)
2:0	Reserved.

3.4.9 HDR1—Header Type Register (Device 1)

Offset: 0Eh
 Default: 01h
 Access: Read Only
 Size: 8 bits

This register identifies the header layout of the configuration space. No physical register exists at this location.

Bit	Descriptions
7:0	Header Type (HEADT). This read only field always returns 01h when read. Writes have no effect.

3.4.10 PBUSN—Primary Bus Number Register (Device 1)

Offset: 18h
 Default: 00h
 Access: Read Only
 Size: 8 bits

This register identifies that “virtual” PCI-to-PCI bridge is connected to bus #0.

Bit	Descriptions
7:0	Bus Number. Hardwired to “0”.

3.4.11 SBUSN—Secondary Bus Number Register (Device 1)

Offset: 19h
 Default: 00h
 Access: Read /Write
 Size: 8 bits

This register identifies the bus number assigned to the second bus side of the “virtual” PCI-to-PCI bridge i.e. to AGP. This number is programmed by the PCI configuration software to allow mapping of configuration cycles to AGP.

Bit	Descriptions
7:0	Bus Number. Programmable Default “0”.

3.4.12 SUBUSN—Subordinate Bus Number Register (Device 1)

Offset: 1Ah
 Default: 00h
 Access: Read /Write
 Size: 8 bits

This register identifies the subordinate bus (if any) that resides at the level below AGP. This number is programmed by the PCI configuration software to allow mapping of configuration cycles to AGP.

Bit	Descriptions
7:0	Bus Number. Programmable.

3.4.13 SMLT—Secondary Master Latency Timer Register (Device 1)

Address Offset: 1Bh
 Default Value: 00h
 Access: Read/Write
 Size: 8 bits

This register control the bus tenure of the 82443BX on AGP the same way the Device 0 MLT controls the access to the PCI bus.

Bit	Description
7:3	Secondary MLT Counter Value. The default is 0s (i.e., SMLT disabled)
2:0	Reserved.

3.4.14 IOBASE—I/O Base Address Register (Device 1)

Address Offset: 1Ch
 Default Value: F0h
 Access: Read/Write
 Size: 8 bits

This register control the CPU to AGP I/O access routing based on the following formula:

$$IO_BASE = \ll address = \ll IO_LIMIT$$

Bit	Description
7:4	I/O Address Base. Corresponds to A[15:12] of the I/O address. Default = Fh
3:0	Reserved.

3.4.15 IOLIMIT—I/O Limit Address Register (Device 1)

Address Offset: 1Dh
 Default Value: 00h
 Access: Read/Write
 Size: 8 bits

This register controls the CPU to AGP I/O access routing based on the following formula:

$$\text{IO_BASE} = \langle \text{address} \rangle \ll \text{IO_LIMIT}$$

Bit	Description
7:4	I/O Address Limit. Corresponds to A[15:12] of the I/O address. Default=0
3:0	Reserved. (Only 16 bit addressing supported.)

3.4.16 SSTS—Secondary PCI-to-PCI Status Register (Device 1)

Address Offset: 1E–1Fh
 Default Value: 02A0h
 Access: Read Only, Read/Write Clear
 Size: 16 bits

SSTS is a 16-bit status register that reports the occurrence of error conditions associated with secondary side (i.e. AGP side) of the “virtual” PCI-to-PCI bridge embedded within 82443BX.

Bit	Descriptions
15	Detected Parity Error (DPE1). Note that the PERRE1 bit does not affect the function of this bit. Also the PERR# is not implemented in the 82443BX. 1 = 82443BX detected of a parity error in the address or data phase of AGP bus transactions. 0 = Software sets DPE1 to 0 by writing a 1 to this bit.
14	Received System Error (SSE1). 1 = 82443BX asserted SERR# for any enabled error condition under device 1. Device 1 error conditions are enabled in the SSTS and BCTRL registers. 0 = Software clears SSE1 to 0 by writing a 1 to this bit.
13	Received Master Abort Status (RMAS1). 1 = 82443BX terminates a Host-to-AGP with an unexpected master abort. 0 = Software resets this bit to 0 by writing a 1 to it.
12	Received Target Abort Status (RTAS1). 1 = 82443BX-initiated transaction on AGP is terminated with a target abort. 0 = Software resets RTAS1 to 0 by writing a 1 to it.
11	Signaled Target Abort Status (STAS1). STAS1 is hardwired to a 0, since the 82443BX does not generate target abort on AGP.
10:9	DEVSEL# Timing (DEVT1). This 2-bit field indicates the timing of the DEVSEL# signal when the 82443BX responds as a target on AGP, and is hard-wired to the value 01b (medium) to indicate the time when a valid DEVSEL# can be sampled by the initiator of the PCI cycle. 01 = Medium. (hardwired)
8	Data Parity Detected (DPD1). Hardwired to 0. 82443BX does not implement G_PERR# function. However, data parity errors are still detected and reported on SERR# (if enabled by SERRE, SERRE1 and the BCTRL register, bit 0).
7	Fast Back-to-Back (FB2B1). This bit is hardwired to 1. The 82443BX as a target supports fast back-to-back transactions on AGP.
6	Reserved.
5	66/60MHZ Capability. Hardwired to 1.
4:0	Reserved.

3.4.17 MBASE—Memory Base Address Register (Device 1)

Address Offset: 20–21h
 Default Value: FFF0h
 Access: Read/Write
 Size: 16 bits

This register controls the CPU to AGP non-prefetchable memory access routing based on the following formula:

$$\text{MEMORY_BASE} = \text{address} = \text{MEMORY_LIMIT}$$

This register must be initialized by the configuration software.

Bit	Description
15: 4	Memory Address Base (MEM_BASE) . Corresponds to A[31:20] of the memory address. Default=FFF0h
3:0	Reserved.

3.4.18 MLIMIT—Memory Limit Address Register (Device 1)

Address Offset: 22–23h
 Default Value: 0000h
 Access: Read/Write
 Size: 16 bits

This register controls the CPU to AGP non-prefetchable memory access routing based on the following formula:

$$\text{MEMORY_BASE} = \text{address} = \text{MEMORY_LIMIT}$$

This register must be initialized by the configuration software.

Note: Memory range covered by MBASE and MLIMIT registers are used to map non-prefetchable AGP address ranges (typically where control/status memory-mapped I/O data structures of the graphics controller will reside) and PMBASE and PMLIMIT are used to map prefetchable address ranges (typically graphics local memory). This segregation allows application of USWC space attribute to be performed in a true plug-and-play manner to the prefetchable address range for improved CPU-AGP memory access performance.

Note: The configuration software is responsible for programming all address range registers (prefetchable, non-prefetchable) with the values that provide exclusive address ranges i.e. prevent overlap with each other and/or with the ranges covered with the main memory. There is no provision in the 82443BX hardware to enforce prevention of overlap and operations of the system in the case of overlap are not guaranteed.

Bit	Description
15: 4	Memory Address Limit (MEM_LIMIT) . Corresponds to A[31:20] of the memory address. Default=0
3:0	Reserved.

3.4.19 PMBASE—Prefetchable Memory Base Address Register (Device 1)

Address Offset: 24–25h
 Default Value: FFF0h
 Access: Read/Write
 Size: 16 bits

This register controls the CPU to AGP prefetchable memory accesses routing based on the following formula:

$$\text{PREFETCHABLE_MEMORY_BASE} = \langle \text{address} \rangle \langle \text{PREFETCHABLE_MEMORY_LIMIT} \rangle$$

This register must be initialized by the configuration software.

Bit	Description
15: 4	Prefetchable Memory Address Base (PMEM_BASE) . Corresponds to A[31:20] of the memory address. Default=FFF0h
3:0	Reserved.

3.4.20 PMLIMIT—Prefetchable Memory Limit Address Register (Device 1)

Address Offset: 26–27h
 Default Value: 0000h
 Access: Read/Write
 Size: 16 bits

This register controls the CPU to AGP prefetchable memory accesses routing based on the following formula:

$$\text{PREFETCHABLE_MEMORY_BASE} = \langle \text{address} \rangle \langle \text{PREFETCHABLE_MEMORY_LIMIT} \rangle$$

This register must be initialized by the configuration software.

Note: The prefetchable memory range is supported to allow segregation by the configuration software between the memory ranges that must be defined as Uncachable and the ones that can be designated as a USWC (i.e. prefetchable) from the CPU perspective.

Bit	Description
15: 4	Prefetchable Memory Address Limit (PMEM_LIMIT) . Corresponds to A[31:20] of the memory address. Default=0
3:0	Reserved.

3.4.21 BCTRL—PCI-to-PCI Bridge Control Register (Device 1)

Address Offset: 3Eh
 Default: 80h
 Access: Read/Write
 Size: 8 bits

This register provides extensions to the PCICMD1 register that are specific to PCI-to-PCI bridges. The BCTRL provides additional control for the secondary interface (i.e., AGP) as well as some bits that affect the overall behavior of the “virtual” PCI-to-PCI bridge in the 82443BX (e.g., VGA compatible address ranges mapping).

Bit	Descriptions
7	Fast Back to Back Enable. 82443BX supports fast back-to-back cycles on AGP, and therefore this bit is hardwired to 1.
6	Secondary Bus Reset: 82443BX does not support generation of reset via this bit on the AGP and therefore this bit is hardwired to 0. NOTE: The only way to perform a hard reset of the AGP is via the system reset either initiated by software or hardware via PIIX4E.
5	Master Abort Mode. Not applicable. Hardwired to 0. (This means when acting as a master on AGP the 82443BX will drop writes on the “floor” and return all 1s during reads.)
4	Reserved.
3	VGA Enable. Controls the routing of CPU-initiated transactions targeting VGA compatible I/O and memory address ranges. 1 = 82443BX will forward the following CPU accesses to AGP: <ul style="list-style-type: none"> memory accesses in the range 0A0000h to 0BFFFFh I/O addresses where A[9:0] are in the ranges 3B0h to 3BBh and 3C0h to 3DFh (inclusive of ISA address aliases - A[15:10] are not decoded) When this bit is set, forwarding of these accesses issued by the CPU is independent of the I/O address and memory address ranges defined by the previously defined base and limit registers. Forwarding of these accesses is also independent of the settings of bit 2 (ISA Enable) of this register or of bit 5 (VGA Palette Snoop Enable) of the PCICMD1 register if this bit is 1. 0 = VGA compatible memory and I/O range accesses are mapped to PCI unless they are redirected to AGP via I/O and memory range registers defined above (IOBASE, IOLIMIT, MBASE, MLIMIT, PMBASE, PMLIMIT). (default)
2	ISA Enable. Modifies the response by the 82443BX to an I/O access issued by the CPU that target ISA I/O addresses. This applies only to I/O addresses that are enabled by the IOBASE and IOLIMIT registers. 1 = When this bit is set to 1 82443BX will not forward to AGP any I/O transactions addressing the last 768 bytes in each 1KB block even if the addresses are within the range defined by the IOBASE and IOLIMIT registers. Instead going to AGP these cycles will be forwarded to PCI where they can be subtractively or positively claimed by the ISA bridge. 0 = All addresses defined by the IOBASE and IOLIMIT for CPU I/O transactions will be mapped to AGP. (default)
1	Reserved.
0	Parity Error Response Enable. Controls 82443BX's response to data phase parity errors on AGP. G_PERR# is not implemented by the 82443BX. However, when this bit is set to 1, address and data parity errors on AGP are reported via SERR# mechanism, if enabled by SERRE1 and SERRE. If this bit is reset to 0, then address and data parity errors on AGP are not reported via the 82443BX SERR# signal. Other types of error conditions can still be signaled via SERR# independent of this bit's state. 1 = Enable. 0 = Disable.

Functional Description

4

This chapter describes the 82443BX interfaces on-chip functional units. Section 4.1, “System Address Map” on page 4-1 provides a system-level address memory map and describes the memory space controls provided by the 82443BX. This section also describes the I/O address map. Note that 82443BX register maps are provided in Chapter 3, “Register Description”.

The 82443BX Host-to-PCI Bridge functions are described Host, PCI, and AGP interfaces are described in Section 4.2, “Host Interface” on page 4-10, Section 4.4, “PCI Interface” on page 4-24, and Section 4.5, “AGP Interface” on page 4-24.

The DRAM interface including supported DRAM types, organizations, configurations, and register programming considerations is provided in Section 4.3, “DRAM Interface” on page 4-14. Data integrity support on the Host bus, PCI bus, and DRAM interface is described in Section 4.6, “Data Integrity Support” on page 4-25.

System clocking requirements is provided in Section 4.7, “System Clocking” on page 4-28.

The 82443BX has various power management capabilities. Suspend resume, clock control, SDRAM power down, and SMRAM functions are described in Section 4.8, “Power Management” on page 4-28. This section also contains information on the 82443BX reset operations.

4.1 System Address Map

A Pentium® Pro processor-based system with the Intel® 440BX AGPset supports 4 GB of addressable memory space and 64 KB + 3 of addressable I/O space. (The Pentium® Pro processor bus I/O addressability is 64 KB + 3). There is a programmable memory address space under the 1 MB region which is divided into regions which can be individually controlled with programmable attributes such as Disable, Read/Write, Write Only, or Read Only. Attribute programming is described in the Register Description section. This section focuses on how the memory space is partitioned and what these separate memory regions are used for. The I/O address space requires much simpler mapping and it is explained at the end of this section.

The Pentium Pro processor family supports addressing of memory ranges larger than 4 GB. The 82443BX Host Bridge claims any access over 4 GB by terminating transaction (without forwarding it to PCI or AGP). Writes are terminated simply by dropping the data and for reads the 82443BX returns all zeros on the host bus. Note that the 82443BX as a target does not support the PCI Dual Address Cycle Mechanism (DAC) which allows addressing of >4GB on either the PCI or AGP interface.

In the following sections, it is assumed that all of the compatibility memory ranges reside on PCI. The exception to this rule are the VGA ranges which may be mapped to AGP. In the absence of more specific references, cycle descriptions referencing PCI should be interpreted as PCI, while cycle descriptions referencing AGP are relate to AGP.

4.1.1 Memory Address Ranges

Figure 4-1 provides a detailed 82443BX memory map indicating specific memory regions defined by AGP and supported by the Intel® 440BX AGPset.

Figure 4-1. Memory System Address Space

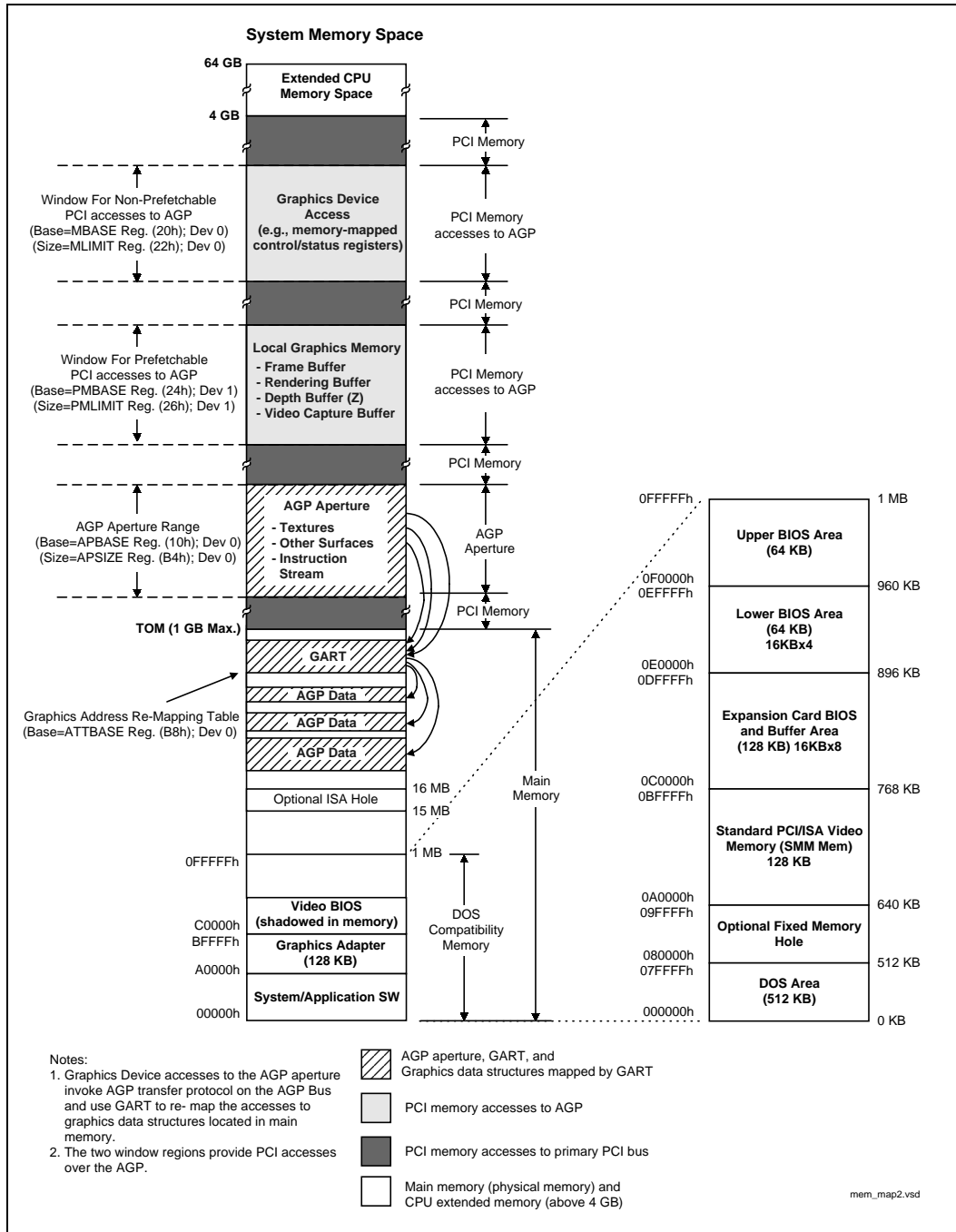

4.1.1.1 Compatibility Area

This area is divided into the following address regions:

- 0–512 KB DOS Area
- 512 KB – 640 KB DOS Area - Optional ISA/PCI Memory
- 640KB – 768 KB Video Buffer Area
- 768 KB – 896 KB in 16KB sections (total of 8 sections) - Expansion Area
- 896KB – 960 KB in 16KB sections (total of 4 sections) - Extended System BIOS Area
- 960 KB – 1 MB Memory (BIOS Area) - System BIOS Area

There are sixteen memory segments in the compatibility area. Thirteen of the memory ranges can be enabled or disabled independently for both read and write cycles. One segment (512 KB–640 KB) which can be mapped to either main DRAM or PCI.

Table 4-1. Memory Segments and their Attributes

Memory Segments	Attributes	Comments
000000h–07FFFFh	fixed - always mapped to main DRAM	0 – 512 KB; DOS Region
080000h–09FFFFh	configurable as PCI or main DRAM	512 KB – 640 KB; DOS Region
0A0000h–0BFFFFh	mapped to PCI - configurable as SMM space	Video Buffer (physical DRAM configurable as SMM space)
0C0000h–0C3FFFh	WE; RE	Add-on BIOS
0C4000h–0C7FFFh	WE; RE	Add-on BIOS
0C8000h–0CBFFFh	WE; RE	Add-on BIOS
0CC000h–0CFFFFh	WE; RE	Add-on BIOS
0D0000h–0D3FFFh	WE; RE	Add-on BIOS
0D4000h–0D7FFFh	WE; RE	Add-on BIOS
0D8000h–0DBFFFh	WE; RE	Add-on BIOS
0DC000h–0DFFFFh	WE; RE	Add-on BIOS
0E0000h–0E3FFFh	WE; RE	BIOS Extension
0E4000h–0E7FFFh	WE; RE	BIOS Extension
0E8000h–0EBFFFh	WE; RE	BIOS Extension
0EC000h–0EFFFFh	WE; RE	BIOS Extension
0F0000h–0FFFFFFh	WE; RE	BIOS Area

DOS Area (00000h–9FFFFh)

The DOS area is 640 KB and it is further divided into two parts. The 512 KB area at 0 to 7FFFFh is always mapped to the main memory controlled by the 82443BX, while the 128 KB address range from 080000 to 09FFFFh can be mapped to PCI or to main DRAM. By default this range is mapped to main memory and can be declared as a main memory hole (accesses forwarded to PCI) via the 82443BX's FDHC configuration register.

Video Buffer Area (A0000h–BFFFFh)

The 128 KB graphics adapter memory region is normally mapped to a legacy video device on PCI (typically VGA controller). This area is not controlled by attribute bits and CPU-initiated cycles in this region are forwarded to PCI or AGP for termination. This region is also the default region for SMM space.

The SMRAM Control register controls how SMM accesses to this space are treated.

Monochrome Adapter (MDA) Range (B0000h–B7FFFh)

Legacy support requires the ability to have a second graphics controller (monochrome) in the system. In an AGP system, accesses in the normal VGA range are forwarded to the AGP bus. Since the monochrome adapter may be on the PCI (or ISA) bus, the 82443BX must decode cycles in the MDA range and forward them to PCI.

Expansion Area (C0000h–DFFFFh)

This 128 KB ISA Expansion region is divided into eight 16 KB segments. Each segment can be assigned one of four Read/Write states: read-only, write-only, read/write, or disabled. Typically, these blocks are mapped through the Host-to-PCI bridge and are subtractively decoded to ISA space. Memory that is disabled is not remapped.

Extended System BIOS Area (E0000h–EFFFFh)

This 64 KB area is divided into four 16 KB segments. Each segment can be assigned independent read and write attributes so it can be mapped either to main DRAM or to PCI. Typically, this area is used for RAM or ROM. Memory segments that are disabled are not remapped elsewhere.

System BIOS Area (F0000h–FFFFFh)

This area is a single 64 KB segment. This segment can be assigned read and write attributes. It is by default (after reset) Read/Write disabled and cycles are forwarded to PCI. By manipulating the Read/Write attributes, the 82443BX can “shadow” BIOS into the main DRAM. When disabled, this segment is not remapped.

4.1.1.2 Extended Memory Area

This memory area covers 100000h (1 MB) to FFFFFFFFh (4 GB-1) address range and it is divided into the following regions:

- Main DRAM Memory from 1 MB to the Top of Memory; maximum of 256 MB using 16M DRAM technology or 1 GB using 64M technology
- PCI Memory space from the Top of Memory to 4 GB with two specific ranges:
 - APIC Configuration Space from FEC0_0000h (4 GB-20 MB) to FECF_FFFFh and EE0_0000h to FEEF_FFFFh
 - High BIOS area from 4 GB to 4 GB – 2 MB

Main DRAM Address Range (0010_0000h to Top of Main Memory)

The address range from 1 MB to the top of main memory is mapped to main DRAM address range controlled by the 82443BX. All accesses to addresses within this range will be forwarded by the 82443BX to the DRAM unless a hole in this range is created using the fixed hole as controlled by the FDHC register. Accesses within this hole are forwarded to PCI.

The range of physical DRAM memory disabled by opening the hole is not remapped to the Top of the Memory.

Extended SMRAM Address Range (Top of Main Memory – TSEG)

An extended SMRAM space of up to 1 MB can be defined in the address range at the top of memory. The size of the SMRAM space is determined by the TSEG value in the ESMRAMC register. When the extended SMRAM space is enabled, non-SMM CPU accesses and all PCI and

AGP accesses in this range are forwarded to PCI. When SMM is enabled the amount of memory available to the system is equal to the amount of physical DRAM minus the value in the TSEG register.

Note: When extended SMRAM is used, the maximum amount of DRAM supported is limited to 256 MB.

PCI Memory Address Range (Top of Main Memory to 4 GB)

The address range from the top of main DRAM to 4 GB (top of physical memory space supported by the Intel® 440BX AGPset) is normally mapped to PCI. There are two exceptions to this rule:

- Addresses decoded to the AGP Memory Window defined by the MBASE, MLIMIT, PMBASE, and PMLIMIT registers are mapped to AGP.
- Addresses decoded to the Graphics Aperture range defined by the APBASE and APSIZE registers are mapped to the main DRAM.

There are two sub-ranges within the PCI Memory address range defined as APIC Configuration Space and High BIOS Address Range. The AGP Memory Window and Graphics Aperture Window **MUST NOT** overlap with these two ranges. These ranges are described in detail in the following paragraphs.

APIC Configuration Space (FEC0_0000h -FECF_FFFFh, FEE0_0000h- FEEF_FFFFh)

This range is reserved for APIC configuration space which includes the default I/O APIC configuration space. The default Local APIC configuration space is FEE0_0000h to FEEF_0FFFh.

CPU accesses to the Local APIC configuration space do not result in external bus activity since the Local APIC configuration space is internal to the CPU. However, a MTRR must be programmed to make the Local APIC range uncacheable (UC). The Local APIC base address in each CPU should be relocated to the FEC0_0000h (4 GB – 20 MB) to FECF_FFFFh range so that one MTRR can be programmed to 64 KB for the Local and I/O APICs. The I/O APIC(s) usually reside in the I/O Bridge portion of the AGPset or as a stand-alone component(s). For Intel® 440BX AGPset systems using the PIIX4E, the I/O APIC is supported as a stand-alone component residing on the X-Bus.

I/O APIC units will be located beginning at the default address FEC0_0000h. The first I/O APIC will be located at FEC0_0000h. Each I/O APIC unit is located at FEC0_x000h where x is I/O APIC unit number 0 through F (hex). This address range will be normally mapped to PCI.

Note: There is no provision to support an I/O APIC device on AGP. Also the I/O APIC is not supported in a mobile platform.

The address range between the APIC configuration space and the High BIOS (FED0_0000h to FEDF_FFFFh) is always mapped to the PCI.

High BIOS Area (FFE0_0000h –FFFF_FFFFh)

The top 2 MB of the Extended Memory Region is reserved for System BIOS (High BIOS), extended BIOS for PCI devices, and the A20 alias of the system BIOS. CPU begins execution from the High BIOS after reset. This region is mapped to PCI so that the upper subset of this region aliases to 16 MB–256 KB range. The actual address space required for the BIOS is less than 2 MB but the minimum CPU MTRR range for this region is 2 MB so that full 2 MB must be considered. The PIIX4E supports a maximum of 1 MB in the High BIOS range.

4.1.1.3 AGP Memory Address Range

The 82443BX can be programmed to direct memory accesses to the AGP bus interface when addresses are within either of two ranges specified via registers in 82443BX Device #1 configuration space. The first range is controlled via the Memory Base Register (MBASE) and Memory Limit Register (MLIMIT) registers. The second range is controlled via the Prefetchable Memory Base (PMBASE) and Prefetchable Memory Limit (PMLIMIT) registers

The 82443BX positively decodes memory accesses to AGP memory address space as defined by the following equations:

$$\text{Memory_Base_Address} \leq \text{Address} \leq \text{Memory_Limit_Address}$$

$$\text{Prefetchable_Memory_Base_Address} \leq \text{Address} \leq \text{Prefetchable_Memory_Limit_Address}$$

The effective size of the range is programmed by the plug-and-play configuration software and it depends on the size of memory claimed by the AGP compliant device. Normally, these ranges reside above the Top-of-Main-DRAM and below High BIOS and APIC address ranges.

Note: The 82443BX Device #1 memory range registers described above are used to allocate memory address space for any devices on AGP that require such a window. These devices include the AGP compliant device, and multifunctional AGP compliant devices where one or more functions are implemented as PCI devices.

4.1.1.4 AGP DRAM Graphics Aperture

Memory-mapped, graphics data structures can reside in a *Graphics Aperture* to main DRAM memory. This aperture is an address range defined by the APBASE configuration register of the 82443BX Host Bridge. The APBASE register follows the normal base address register template as defined by the PCI 2.1 specification. The size of the range claimed by the APBASE is programmed via “back-end” register APSIZE (programmed by the chip-set specific BIOS before plug-and-play session is performed). APSIZE allows selection of the aperture size of 4 MB, 8 MB, 16 MB, 32 MB, 64 MB, 128 MB and 256 MB. By programming APSIZE to a specific size, the corresponding lower bits of APBASE are forced to “0” (behave as hardwired). Default value of APSIZE forces aperture size of 256 MB. Aperture address range is naturally aligned.

Although this aperture appears to be established in PCI memory space, in fact the 82443BX forwards accesses within the aperture range to the main DRAM subsystem. The originally issued addresses are translated (within 82443BX’s DRAM controller subsystem) via a translation table maintained in main memory. Translation table entries may be partially cached in a Graphics Translation Look-aside Buffer (GTLB) implemented within the 82443BX’s DRAM subsystem. The aperture range will not be cacheable in the processor caches.

4.1.1.5 System Management Mode (SMM) Memory Range

82443BX supports the use of main memory as System Management RAM (SMRAM) enabling the use of System Management Mode. The 82443BX supports two SMRAM options: Compatible SMRAM (C_SMRAM) and Extended SMRAM (E_SMRAM). System Management RAM (SMRAM) space provides a memory area that is available for the SMI handler's and code and data storage. This memory resource is normally hidden from the system OS so that the processor has immediate access to this memory space upon entry to SMM. The 82443BX provides three SMRAM options:

- Below 1 MB option that supports compatible SMI handlers.
- Above 1 MB option that allows new SMI handlers to execute with write-back cacheable SMRAM.
- Optional larger write-back cacheable T_SEG area from 128KB to 1MB in size above 1 MB that is reserved from the highest area in system DRAM memory. The above 1 MB solutions require changes to compatible SMRAM handlers code to properly execute above 1 MB.

Table 4-2 summarizes the operation of SMRAM space cycles targeting the SMI space addresses.

Table 4-2. SMRAM Decoding

Name of Range	Transaction Address	DRAM Address
compatible (Range A)	A0000–BFFFFh	A0000–BFFFFh
HI-SMRAM (RANGE H)	256M + A0000h to 256M + FFFFFh	A0000–FFFFFh
TSEG (RANGE T)	256M + TOM to 256M + TOM - TSEG_SIZE	TOM to TOM - TSEG_SIZE

Table 4-3. SMRAM Range Decode

Global SMRAM	H_SMRAME	TSEG_EN	A Range	H Range	T Range
0	x	x	Disable	Disable	Disable
1	0	0	Enable	Disable	Disable
1	0	1	Enable	Disable	Enable
1	1	0	Disabled	Enable	Disable
1	1	1	Disabled	Enable	Enable

NOTE:

1. 1 = Enabled and 0 = Disabled

Table 4-4 defines the control of the decode for all code fetches and data fetches to SMRAM ranges (as defined by Table 4-3). The G_SMRAM bit provides a global disable for all SMRAM memory. The D_OPEN bit allows software to write to the SMRAM ranges without being in SMM. BIOS software can use this bit to initialize SMM code at Power up. The D_LCK bit limits the SMRAM range access to only SMM mode accesses. The D_CLS bit causes SMM data accesses to be forwarded to PCI. The SMM software can use this bit to write to video memory while running code out of DRAM.

Table 4-4. SMRAM Decode Control

G_SMRAME	D_LCK	D_CLS	D_OPEN	SMM Mode	SMM Code Fetch	SMM Data Fetch
0	x	x	x	x	Disable	Disable
1	0	x	0	0	Disable	Disable
1	0	0	0	1	Enable	Enable
1	0	0	1	x	Enable	Enable
1	0	1	0	1	Enable	Disable
1	0	1	1	x	Invalid	Invalid
1	1	x	x	0	Disable	Disable
1	1	0	x	1	Enable	Enable
1	1	1	x	1	Enable	Disable

NOTE:

1. 1 = Enabled and 0 = Disabled

Refer to Section 4.8, “Power Management” on page 4-28 for more details on SMRAM support.

Reiteration:

- Only un-cacheable SMM regions may overlap PCI or AGP Windows.
- SMM regions will not overlap the AGP aperture.
- Software (not in SMM) will not access PCI memory behind cacheable SMM regions.
- PCI or AGP masters cannot access the SMM space.

4.1.2 Memory Shadowing

Any block of memory that can be designated as read-only or write-only can be “shadowed” into 82443BX DRAM memory. Typically, this is done to allow ROM code to execute more rapidly out of main DRAM. ROM is used as a read-only during the copy process while DRAM at the same time is designated write-only. After copying, the DRAM is designated read-only so that ROM is shadowed. CPU bus transactions are routed accordingly.

4.1.3 I/O Address Space

The 82443BX does not support the existence of any other I/O devices besides itself on the CPU bus. The 82443BX generates either PCI or AGP bus cycles for all CPU I/O accesses. The 82443BX contains three internal registers in the CPU I/O space, Configuration Address Register (CONFIG_ADDRESS) and the Configuration Data Register (CONFIG_DATA) and Power Management Control Register. These locations are used to implement PCI configuration space access mechanism and as described in Section 3.1, “I/O Mapped Registers” on page 3-2.

The CPU allows 64K+3 bytes to be addressed within the I/O space. The 82443BX propagates the CPU I/O address without any translation on to the destination bus and therefore provides addressability for 64K+3 byte locations. Note that the upper 3 locations can be accessed only during I/O address wrap-around when CPU bus A16# address signal is asserted. A16# is asserted on the CPU bus whenever an I/O access is made to 4 bytes from address 0FFFDh, 0FFFEh, or 0FFFFh. A16# is also asserted when an I/O access is made to 2 bytes from address 0FFFFh.

The I/O accesses (other than ones used for PCI configuration space access) are forwarded normally to the PCI bus unless they fall within the PCI/AGP I/O address range as defined by the mechanisms in Section 4.1.4. The 82443BX will not post I/O write cycles to IDE.

4.1.4 AGP I/O Address Mapping

The 82443BX can be programmed to direct non-memory (I/O) accesses to the AGP bus interface when CPU-initiated I/O cycle addresses are within the AGP I/O address range. This range is controlled via the I/O Base Address (IOBASE) and I/O Limit Address (IOLIMIT) registers in 82443BX Device #1 configuration space.

The 82443BX positively decodes I/O accesses to AGP I/O address space as defined by the following equation:

$$\text{I/O_Base_Address} \leq \text{CPU I/O Cycle Address} \leq \text{I/O_Limit_Address}$$

The effective size of the range is programmed by the plug-and-play configuration software and it depends on the size of I/O space claimed by the AGP compliant device.

Note that the 82443BX Device #1 I/O address range registers defined above are used for all I/O space allocation for any devices requiring such a window on AGP. These devices would include the AGP compliant device and multifunctional AGP compliant devices where one or more functions are implemented as PCI devices.

4.1.5 Decode Rules and Cross-Bridge Address Mapping

The address map described above applies globally to accesses arriving on any of the three interfaces (i.e., Host bus, PCI or AGP).

4.1.5.1 PCI Interface Decode Rules

The 82443BX accepts accesses from PCI to the following address ranges:

- All memory read and write accesses to Main DRAM
- Memory Write accesses to AGP memory range defined by MBASE, MLIMIT, PMBASE, and PMLIMIT. 82443BX will not respond to memory read accesses to this range.
- Memory read/write accesses to the Graphics Aperture defined by APBASE and APSIZE.

PCI accesses that fall elsewhere within the PCI memory range will not be accepted. PCI cycles not explicitly claimed by the 82443BX are either subtractively decoded or master-aborted on PCI.

4.1.5.2 AGP Interface Decode Rules

Cycles Initiated Using PCI Protocol

Accesses between AGP and PCI are limited to memory writes using the PCI protocol. Write cycles are forwarded to PCI if the addresses are not within main DRAM range, AGP memory ranges, or Graphics Aperture range.

The 82443BX will claim AGP initiated memory read transactions decoded to the main DRAM range or the Graphics Aperture range. All other memory read requests will be master-aborted by the AGP initiator as a consequence of 82443BX not responding to a transaction.

If agent on AGP issues an I/O, PCI Configuration or PCI Special Cycle transaction, the 82443BX will not respond and cycle will result in a master-abort.

Cycles Initiated Using AGP Protocol

All cycles must reference main memory (i.e., main DRAM address range or Graphics Aperture range which is also physically mapped within DRAM but using different address range). AGP-initiated cycles that target DRAM are not snooped on the host bus, even if they fall outside of the AGP aperture range.

If cycle is outside of main memory range then it will terminate as follows:

- Reads: return random value
- Writes: dropped “on the floor” i.e. terminated internally without affecting any buffers or main memory
- ECC errors that occur on reads outside of DRAM are not reported or scrubbed.

4.1.5.3 Legacy VGA Ranges

The legacy VGA memory range A0000h–BFFFFh is mapped either to PCI or to AGP depending on the programming of the BCTRL configuration register in 82443BX Device #1 configuration space, and the NBXCONF (MDAP bit) configuration register in Device #0 configuration space. The same registers control mapping of VGA I/O address ranges. VGA I/O range is defined as addresses where A[9:0] are in the ranges 3B0h to 3BBh and 3C0h to 3DFh (inclusive of ISA address aliases - A[15:10] are not decoded).

Topic	Definition
AGP IO range	The AGP bus can be allocated with 1 block of IO space with a granularity of 4KB. The IO base address register points to the beginning of the AGP IO range while IO limit address register points to the end of this range. The IO range definition is based on the PCI to PCI specification.
ISA_EN	The ISA_EN bit in the 82443BX device1 is necessary in ISA bus based systems where there is a need to allocate IO space to AGP bus devices. This is necessary since legacy ISA devices decode IO range of address [9:0] only and thus the IO address of the devices are aliased for every 1 KB of the 64 KB IO range. Therefore, to provide IO range to AGP bus and maintain the ISA IO legacy rules, the ISA_EN is set. As a result, all CPU cycles in the address ranges: "xxxx_xx01_0000_0000"b to "xxxx_xx11_1111_1111"b, that is the top 768 bytes of each 1KB aligned block, are sent to the PCI bus independent of whether this particular address is inside or outside the range allocated to the AGP bus. The above is relevant only to CPU-initiated cycles, as PCI and AGP master IO cycles are never claimed by the 82443BX. The ISA_EN functional definition is based on the PCI to PCI specification.
VGA_EN	VGA IO range is defined in the following ranges: 3B0-3BBh, 3C0-3DFh. When the VGA_EN is set, all CPU initiated IO cycles in the VGA IO range are forwarded to the AGP bus, independent of whether the ISA_EN bit is set or not. Thus the VGA_EN bit setting takes precedence relative to the setting of the ISA_EN bit. The VGA_EN functional definition is based on the PCI to PCI specification.
MDAP	The MDA IO range includes the ports 3B4h, 3B5h, 3B8h, 3B9h, 3BAh, 3BFh. Once the VGA_EN is set, it is legal to set the MDAP bit to indicate that a second CRT controller (Monochrome Display Adapter) resides in the PCI or ISA bus. In this case, all the CPU-initiated IO cycles in the VGA range that are not in to the above ports are sent to AGP bus while the cycles to the above six IO ports (and to all the aliased ports) are sent to PCI bus. Note that the CPU IO cycles to the above ports are sent to AGP bus independent of the AGP IO range and ISA_EN setting.

4.2 Host Interface

The host interface of the 82443BX is optimized to support the Pentium II processor with bus clock frequencies of 100 MHz and 66/60 MHz. The 82443BX implements the host address, control, and data bus interfaces within a single device. Host bus addresses are decoded by the 82443BX for accesses to main memory, PCI memory, PCI I/O, PCI configuration space and AGP space (memory, I/O and configuration). The 82443BX takes advantage of the pipelined addressing capability of the Pentium II processor to improve the overall system performance.

4.2.1 Host Bus Device Support

The 82443BX recognizes and supports a large subset of the transaction types that are defined for the Pentium Pro processor bus interface. However, each of these transaction types have a multitude of response types, some of which are not supported by this controller. All transactions are processed in the order that they are received on the Pentium® Pro processor bus. Table 4-5 summarizes the transactions supported by the 82443BX.

Table 4-5. Host Bus Transactions Supported By 82443BX

Transaction	REQA[4:0]#	REQB[4:0]#	82443BX Support
Deferred Reply	0 0 0 0 0	X X X X X	The 82443BX initiates a deferred reply for a previously deferred transaction.
Reserved	0 0 0 0 1	X X X X X	Reserved
Interrupt Acknowledge	0 1 0 0 0	0 0 0 0 0	Interrupt acknowledge cycles are forwarded to the PCI bus.
Special Transactions	0 1 0 0 0	0 0 0 0 1	See separate table in Special Cycles section.
Reserved	0 1 0 0 0	0 0 0 1 x	Reserved
Reserved	0 1 0 0 0	0 0 1 x x	Reserved
Branch Trace Message	0 1 0 0 1	0 0 0 0 0	The 82443BX terminates a branch trace message without latching data.
Reserved	0 1 0 0 1	0 0 0 0 1	Reserved
Reserved	0 1 0 0 1	0 0 0 1 x	Reserved
Reserved	0 1 0 0 1	0 0 1 x x	Reserved
I/O Read	1 0 0 0 0	0 0 x LEN#	I/O read cycles are forwarded to PCI or AGP. I/O cycles which are in the 82443BX configuration space are not forwarded to PCI.
I/O Write	1 0 0 0 1	0 0 x LEN#	I/O write cycles are forwarded to PCI or AGP. I/O cycles which are in the 82443BX configuration space are not forwarded to PCI.
Reserved	1 1 0 0 x	0 0 x x x	Reserved
Memory Read & Invalidate	0 0 0 1 0	0 0 x LEN#	Host initiated memory read cycles are forwarded to DRAM or the PCI/1 bus. The 82443BX initiates an MRI cycle for a PCI/1 initiated write cycle to DRAM.
Reserved	0 0 0 1 1	0 0 x LEN#	Reserved
Memory Code Read	0 0 1 0 0	0 0 x LEN#	Memory code read cycles are forwarded to DRAM or PCI/1.
Memory Data Read	0 0 1 1 0	0 0 x LEN#	Host initiated memory read cycles are forwarded to DRAM or the PCI/1 bus. The 82443BX initiates a memory read cycle for a PCI/1 initiated read cycle to DRAM.
Memory Write (no retry)	0 0 1 0 1	0 0 x LEN#	This memory write is a writeback cycle and cannot be retried. The 82443BX forwards the write to DRAM.
Memory Write (can be retried)	0 0 1 1 1	0 0 x LEN#	The normal memory write cycle is forwarded to DRAM or PCI/1.

NOTE:

1. For Memory cycles, REQA[4:3]# = ASZ#. The 82443BX only supports ASZ# = 00 (32 bit address).
2. REQb[4:3]# = DSZ#. For the Pentium® Pro processor, DSZ# = 00 (64 bit data bus size).
3. LEN# = data transfer length as follows:

LEN#	Data length
00	≤ 8 bytes (BE[7:0]# specify granularity)
01	Length = 16 bytes BE[7:0]# all active
10	Length = 32 bytes BE[7:0]# all active
11	Reserved

Table 4-6. Host Responses supported by the 82443BX

RS2#	RS1#	RS0#	Description	82443BX Support
0	0	0	idle	
0	0	1	Retry Response	To avoid deadlock, this response is generated when a resource cannot currently be accessed by the processor. PCI-directed reads, writes, DRAM locked reads, AGP reads and writes can be retried.
0	1	0	Deferred Response	This response can be returned for all transactions that can be executed 'out of order.' PCI-directed reads (memory, I/O and Interrupt Acknowledge) and writes (I/O only), and AGP directed reads (memory and I/O) and writes (I/O only) can be deferred.
0	1	1	Reserved	Reserved
1	0	0	Hard Failure	Not supported.
1	0	1	No Data Response	This is for transactions where the data has already been transferred or for transactions where no data is transferred. Writes and zero length reads receive this response.
1	1	0	Implicit Writeback	This response is given for those transactions where the initial transactions snoop hits on a modified cache line.
1	1	1	Normal Data Response	This response is for transactions where data accompanies the response phase. Reads receive this response.

Special Cycles

A Special Cycle is defined when $REQa[4:0] = 01000$ and $REQb[4:0] = xx001$. The first address phase $Aa[35:3]\#$ is undefined and can be driven to any value. The second address phase, $Ab[15:8]\#$ defines the type of Special Cycle issued by the processor.

Table 4-3 specifies the cycle type and definition as well as the action taken by the 82443BX when the corresponding cycles are identified.

Table 4-7. Host Special Cycles with 82443BX

BE[7:0]#	Special Cycle Type	Action Taken
0000 0000	NOP	This transaction has no side-effects.
0000 0001	Shutdown	This transaction is issued when an agent detects a severe software error that prevents further processing. This cycle is claimed by the 82443BX. The 82443BX issues a shutdown special cycle on the PCI bus. This cycle is retired on the CPU bus after it is terminated on the PCI via a master abort mechanism.
0000 0010	Flush	This transaction is issued when an agent has invalidated its internal caches without writing back any modified lines. The 82443BX claims this cycle and retires it.
0000 0011	Halt	This transaction is issued when an agent executes a HLT instruction and stops program execution. This cycle is claimed by the 82443BX and propagated to PCI as a Special Halt Cycle. This cycle is retired on the CPU bus after it is terminated on the PCI via a master abort mechanism.
0000 0100	Sync	This transaction is issued when an agent has written back all modified lines and has invalidated its internal caches. The 82443BX claims this cycle and retires it.

Table 4-7. Host Special Cycles with 82443BX

BE[7:0]#	Special Cycle Type	Action Taken
0000 0101	Flush Acknowledge	This transaction is issued when an agent has completed a cache sync and flush operation in response to an earlier FLUSH# signal assertion. The 82443BX claims this cycle and retires it.
0000 0110	Stop Clock Acknowledge	This transaction is issued when an agent enters Stop Clock mode. This cycle is claimed by the 82443BX and propagated to the PCI as a Special Stop Grant Cycle. This cycle is completed on the CPU bus after it is terminated on the PCI via a master abort mechanism.
0000 0111	SMI Acknowledge	This transaction is first issued when an agent enters the System Management Mode (SMM).
all others	Reserved	

NOTE:

1. None of the host bus special cycles is propagated to the AGP interface.

4.2.2 Symmetric Multiprocessor (SMP) Protocol Support

The Intel® 440BX AGPset is optimized for uniprocessor system and also supports the symmetrical multiprocessor configurations of up to two CPUs on the host bus.

When configured for dual-processor, the Intel® 440BX AGPset-based platform must integrate an I/O APIC functionality and WSC# signaling mechanism must be enabled.

4.2.3 In-Order Queue Pipelining

The 82443BX interface to the CPU bus includes a four deep in-order queue to track pipelined bus transactions.

4.2.4 Frame Buffer Memory Support (USWC)

To allow for high speed write capability for graphics, the Pentium Pro processor family has introduced USWC memory type. The USWC (uncacheable, speculative, write-combining) memory type provides a write-combining buffering mechanism for write operations. A high percentage of graphics transactions are writes to the memory-mapped graphics region, normally known as the linear frame buffer. Reads and writes to USWC are non-cached and can have no side effects.

In the case of graphics, current 32-bit drivers (without modifications) would use Partial Write protocol to update the frame buffer. The highest performance write transaction on the CPU bus is the Line Write.

4.3 DRAM Interface

The 82443BX integrates a main memory DRAM controller that supports a 64-bit or 72-bit (64-bit memory data plus 8 ECC) DRAM array. The DRAM types supported are Synchronous (SDRAM) and Extended Data Out (EDO). The 82443BX does not support mixing of SDRAM and EDO. When the CPU bus is running at 100 MHz, the 82443BX DRAM interface runs at 100 MHz (SDRAM only). When the CPU bus is operating at 66 MHz, the 82443BX DRAM interface runs at 66 MHz (SDRAM or EDO). EDO DRAM technology is supported in mobile designs only at 66 MHz. The DRAM controller interface is fully configurable through a set of control registers. Complete descriptions of these registers are given in the Register Section. A brief overview of the registers which configure the DRAM interface is provided in this section.

The 82443BX supports industry standard 64/72-bit wide DIMM modules with SDRAM and EDO DRAM devices. The fourteen multiplexed address lines, MA[13:0], allow the 82443BX to support 1M, 2M, 4M, 8M, and 16M x72/64 DIMMs. Both symmetric and asymmetric addressing is supported. The 82443BX has sixteen CS# lines, used in pairs enabling the support of up to eight 64/72-bit rows of DRAM. For write operations of less than a QWord in size, the 82443BX will either perform a byte-wise write (non-ECC protected configuration) or a read-modify-write cycle by merging the write data on a byte basis with the previously read data (ECC or EC configurations). The 82443BX targets 60 ns EDO DRAMs and SDRAM with CL2 and CL3 and supports both single and double-sided DIMMs. When using EDO DRAM, up to 6 rows of memory are supported. The 82443BX provides refresh functionality with programmable rate (normal DRAM rate is 1 refresh/15.6ms). When using SDRAMs the 82443BX can be configured via the Paging Policy Register to keep multiple pages open within the memory array. Pages can be kept open in all rows of memory. When 4 bank SDRAM devices (64Mb technology) are used for a particular row, up to 4 pages can be kept open within that row.

The DRAM interface of the 82443BX is configured by the DRAM Control Register, DRAM Timing Register, SDRAM Control Register, bits in the NBXCFG and the eight DRAM Row Boundary (DRB) Registers. The DRAM configuration registers noted above control the DRAM interface to select EDO or SDRAM DRAMs, RAS timings, and CAS rates. The eight DRB Registers define the size of each row in the memory array, enabling the 82443BX to assert the proper CSA/B# pair for accesses to the array.

4.3.1 DRAM Organization and Configuration

The 82443BX supports 64/72-bit DRAM configurations. In the following discussion the term *row* refers to a set of memory devices that are simultaneously selected by a CSA/B# or RASA/B# pair. The 82443BX will support a maximum of 8 rows of memory when using SDRAMs in a desktop configuration. Up to 6 rows of memory are supported when using EDO DRAM. A row may be composed of discrete DRAM devices, single-sided or double-sided DIMMs.

The 82443BX has multiple copies of many of the signals interfacing to memory. The interface consists of the following pins.

- Multiple copies
 - MAA[13:0], MAB[12:11,9:0]# and MAB[13,10]
 - CSA[7:0]#, CSB[7:0]#
 - SRASA#, SRASB#
 - SCASA#, SCASB#
 - WEA#, WEB#
 - DQMA[7:0], DQMB[5,1]
 - CKE[5:0] (for 3 DIMM configuration)

- Single Copy
 - MD[63:0]
 - MECC[7:0]
 - GCKE (for 4 DIMM configuration)
 - FENA (FET switch control for 4 DIMM configuration)

The CS# pins function as RAS# pins in the case of EDO DRAMs. The DQM pins function as CAS# pins in the case of EDO DRAMs. Two CS# lines are provided per row. These are functionally equivalent. The extra copy is provided for loading reasons. The two SRAS#'s, SCAS#'s and WE#'s are also functionally equivalent and each copy drives two rows of DRAM. Most pins utilize programmable strength output buffers (refer to Register Section). When a row contains 16Mb SDRAMs, MAA11 and MAB11 function as Bank Select lines. When a row contains 64Mb SDRAMs, MAA/B[12:11] function as Bank Addresses (BA[1:0], or Bank Selects).

The entire memory array may be configured as either normal SDRAM, registered SDRAM or EDO DRAM. Mixing DRAM types within one system is not supported. DIMMs may be populated in any order. That is, any combination of rows may be populated. Registered SDRAM DIMMs allow for support of x4 SDRAM components.

Table 4-8 illustrates a sample of the possible DIMM socket configurations along with corresponding DRB programming.

Table 4-8. Sample Of Possible Mix And Match Options For 6 Row/3 DIMM Configurations

DIMM0\	DIMM1	DIMM2	DRB 0	DRB 1	DRB 2	DRB 3	DRB 4	DRB 5	DRB 6	DRB 7	Total Memory
0	0	1MB x 72/S	00h	00h	00h	00h	01h	01h	01h	01h	8 MB
1MBx72/S	0	0	01h	01h	01h	01h	01h	01h	01h	01h	8 MB
2MBx72/S	0	0	02h	02h	02h	02h	02h	02h	02h	02h	16 MB
1Mx72/S	1Mx72/S	0	01h	01h	02h	02h	02h	02h	02h	02h	16 MB
0	4Mx72/S	0	00h	00h	04h	04h	04h	04h	04h	04h	32 MB
2Mx72/D	2Mx72/D	2Mx72/D	01h	02h	03h	04h	05h	06h	06h	06h	48 MB
4Mx72/S	0	2Mx72/D	04h	04h	04h	04h	05h	06h	06h	06h	48 MB
4Mx72/S	0	4Mx72/S	04h	04h	04h	04h	08h	08h	08h	08h	64 MB
4Mx72/S	4Mx72/S	2Mx72/D	04h	04h	08h	08h	09h	10h	10h	10h	80 MB
8Mx72/D	0	4Mx72/S	04h	08h	08h	08h	0Ch	0Ch	0Ch	0Ch	96 MB
8Mx72/D	8Mx72/D	8Mx72/D	04h	08h	0Ch	10h	14h	18h	18h	18h	192 MB
16Mx72/S	16Mx72/S	0	10h	10h	20h	20h	20h	20h	20h	20h	256 MB
8Mx72/D	16Mx72/S	8Mx72/D	04h	08h	18h	18h	1Ch	20h	20h	20h	256 MB
0	32Mx72/D	16Mx72/S	00h	00h	10h	20h	30h	30h	30h	30h	384 MB
32Mx72/D	32Mx72/D	16Mx72/S	10h	20h	30h	40h	50h	50h	50h	50h	640 MB

NOTE:

1. "S" denotes single-sided DIMM's, "D" denotes double-sided DIMM's.

Figure 4-2 depicts the 82443BX connections for an SDRAM memory array and shows how the copies of the signals are distributed to the array. If cross bar switches are used, the unused input must be pulled down through a resistor. In an EDO memory array, the CSA/B[5:0]# signals would be RASA/B[5:0]# lines and the DQMA/B[7:0] signals would be CASA/B[7:0]# lines. GCKE requires external logic (not shown). For a 3 DIMM solution, separate CKE lines are provided for each row (CKE[5:0]).

Figure 4-2. Four-DIMM Configuration with FET switches

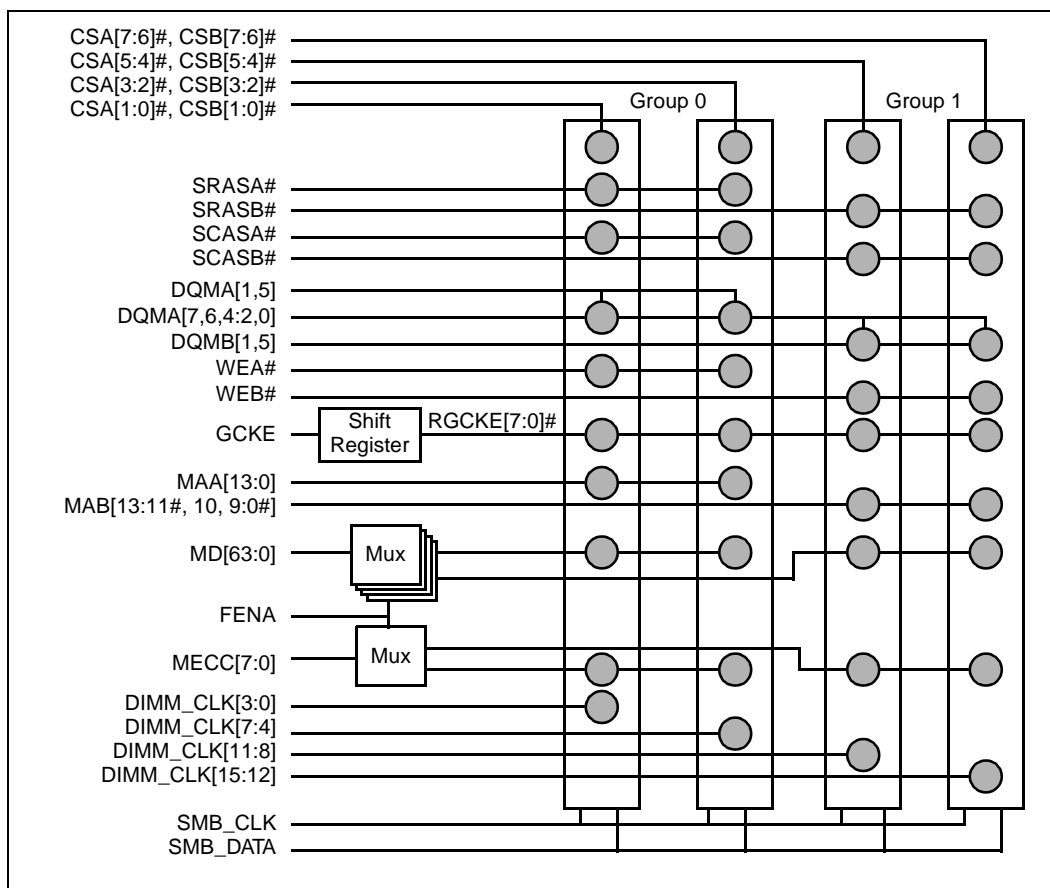

Figure 4-3. Three-DIMM SDRAM Configuration

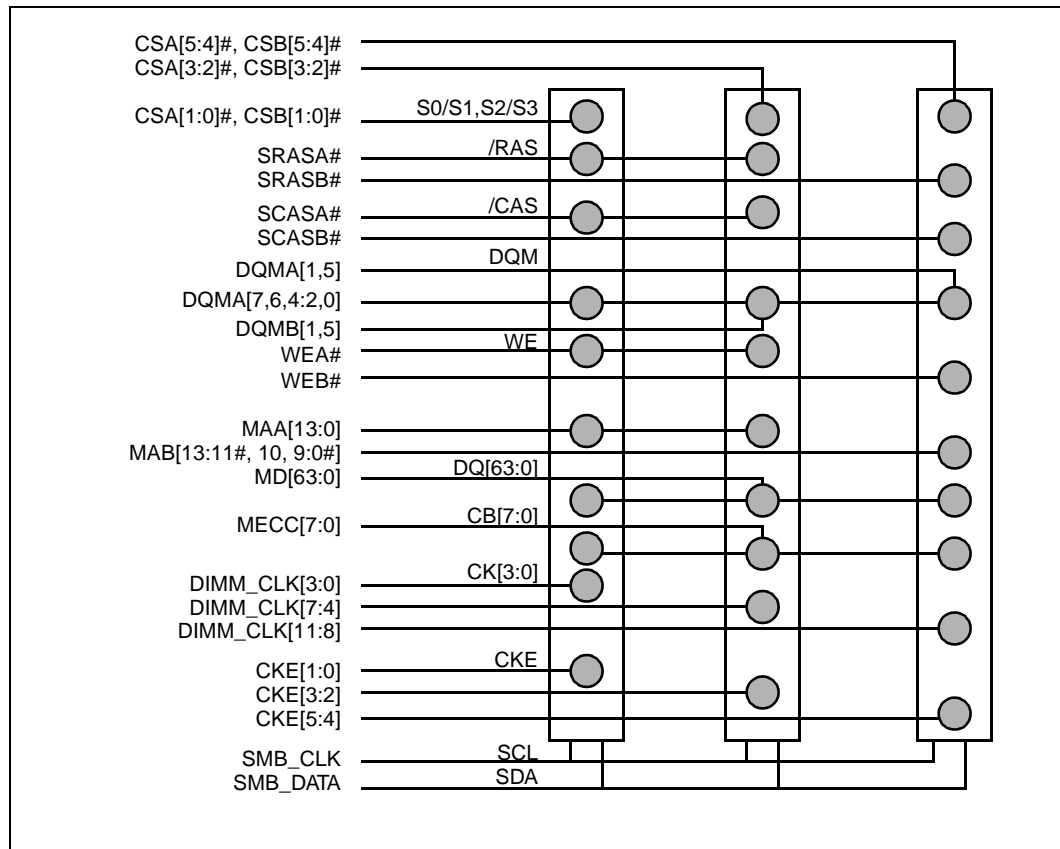

Figure 4-4. Three-SODIMMs EDO Configuration

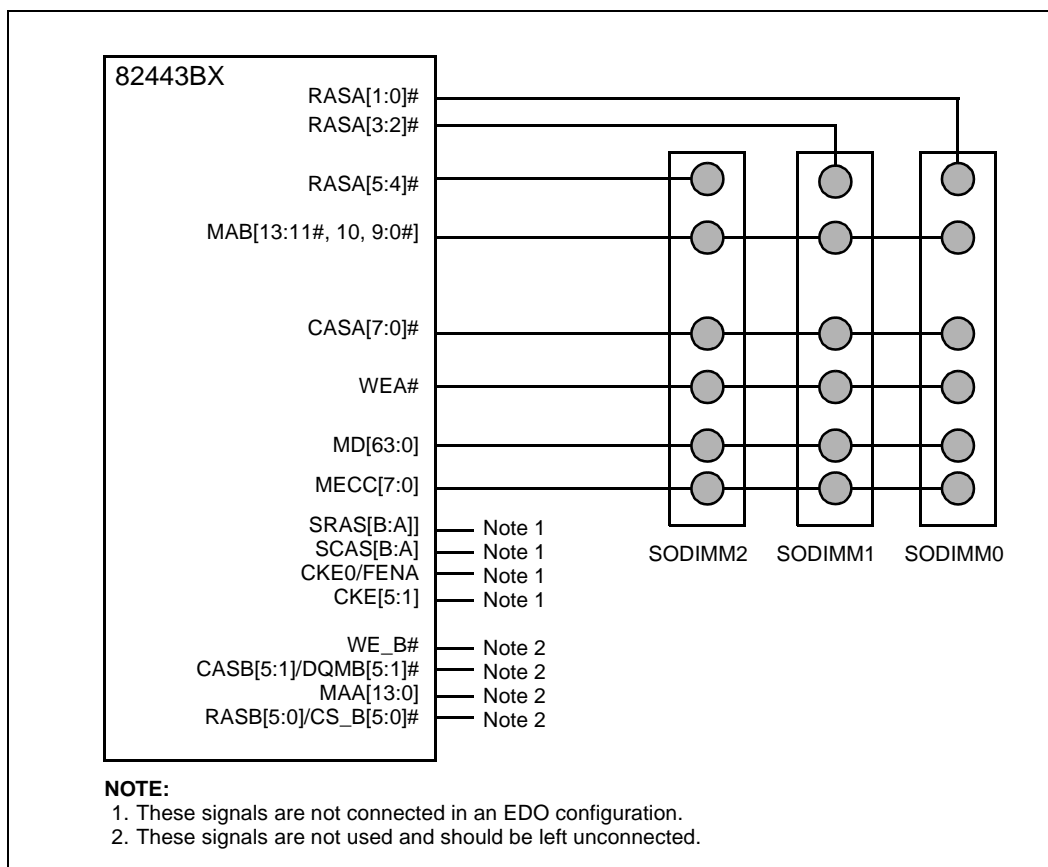
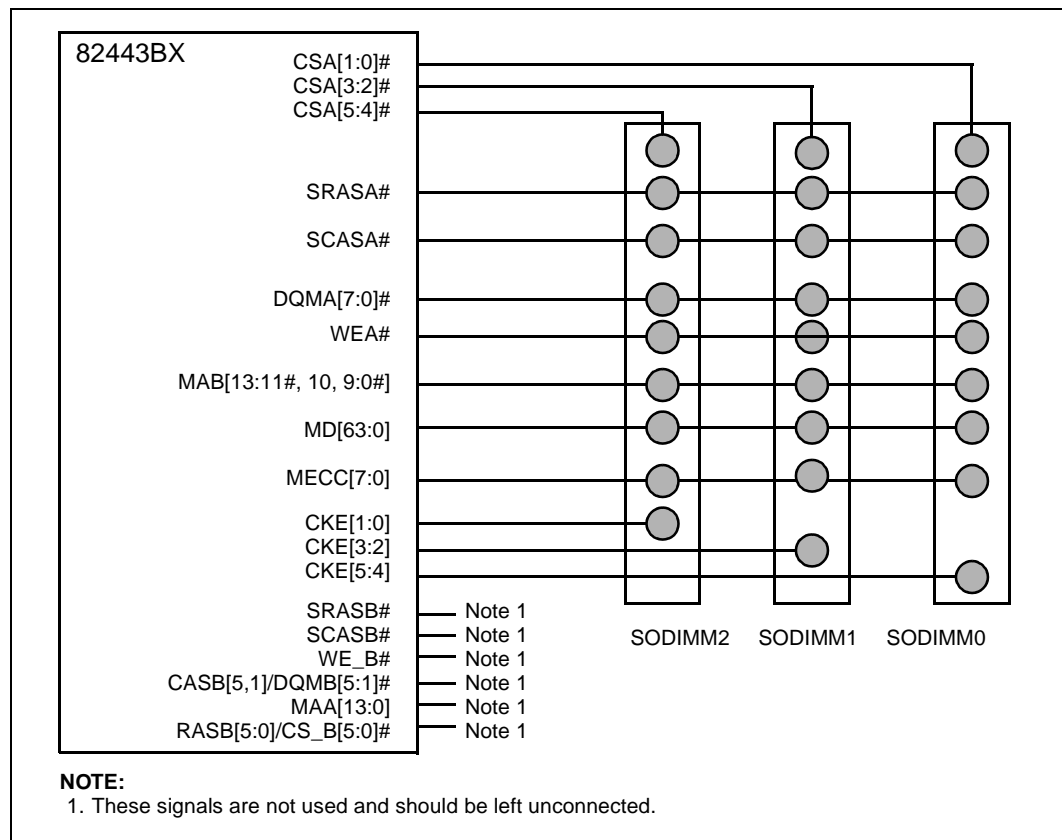

Figure 4-5. Three-SODIMMs SDRAM Configuration

4.3.1.1 Configuration Mechanism For DIMMS

Detection of the type of DRAM installed on the DIMM is supported via Serial Presence Detect mechanism as defined in the JEDEC 168-pin DIMM standard. This standard uses the SCL, SDA and SA[2:0] pins on the DIMMs to detect the type and size of the installed DIMMs. No special programmable modes are provided on the 82443BX for detecting the size and type of memory installed. Type and size detection must be done via the serial presence detection pins.

Memory Detection and Initialization

Before any cycles to the memory interface can be supported, the 82443BX DRAM registers must be initialized. The 82443BX must be configured for operation with the installed memory types. Detection of memory type and size is done via the System Management Bus (SMB) interface on the PIIX4E. This two wire bus is used to extract the DRAM type and size information from the serial presence detect port on the DRAM DIMMs.

DRAM DIMMs contain a 5 pin serial presence detect interface, including SCL (serial clock), SDA (serial data) and SA[2:0]. Devices on the SMBus bus have a seven bit address. For the DRAM DIMMs, the upper four bits are fixed at 1010. The lower three bits are strapped on the SA[2:0] pins. SCL and SDA are connected directly to the System Management Bus on the PIIX4E. Thus data is read from the Serial Presence Detect port on the DIMMs via a series of IO cycles to the south bridge. BIOS essentially needs to determine the size and type of memory used for each of the eight rows of memory in order to properly configure the 82443BX memory interface.

DRAM Register Programming

The Serial Presence Detect ports are used to determine Refresh Rate, MA and MD Buffer Strength, Row Type (on a row by row basis), EDO Timings, SDRAM Timings, Row Sizes and Row Page Sizes. Table 4-9 lists a subset of the data available through the on board Serial Presence Detect ROM on each DIMM.

Table 4-9. Data Bytes on DIMM Used for Programming DRAM Registers

Byte	Function
2	Memory Type (EDO, SDRAM)
3	# of Row Addresses, not counting Bank Addresses
4	# of Column Addresses
5	# of banks of DRAM (Single or Double sided) DIMM
11	ECC, no ECC
12	Refresh Rate
17	# Banks on each SDRAM Device
36-41	Access Time from Clock for CAS# Latency 1 through 7
42	Data Width of SDRAM Components

Table 4-9 is only a subset of the defined SPD bytes on the DIMMs. For example, to program the DRB (DRAM Row Boundary) registers, the size of each row must be determined. The number of row addresses (byte 3) plus the number of column addresses (byte 4) plus the number of banks on each SDRAM device (byte 17) collectively determines the total address depth of a particular row of SDRAM. Since a row is always 64 data bits wide, the size of the row is easily determined for programming the DRB registers.

The 82443BX uses the DRAM Row Type information in conjunction with the DRAM timings set in the DRAM Timing Register to configure DRAM accesses optimally.

4.3.2 DRAM Address Translation and Decoding

The 82443BX supports 16 and 64 Mbit DRAM devices. The 82443BX supports a 2 KB, 4 KB and 8 KB page sizes (for SDRAM only). Page size varies per row depending on how many column address lines are used for a given row. Rows containing SDRAMs with 8 column lines have a 2 KB page size. Those with 9 column lines have a 4 KB page size and those with 10 column address lines have an 8 KB page size. In systems with EDO memory, a fixed 2 KB page size is used. The multiplexed row/column address to the DRAM memory array is provided by the MA[13:0] signals.

Row and Column address multiplexing on the MA[13:0] lines is determined on a row by row basis allowing for three possible page sizes. SDRAMs have either 8, 9 or 10 column lines allowing for 2 KB, 4 KB or 8 KB page sizes. The 82443BX supports only a 2 KB page size with EDO DRAMs. The page size is determined primarily by the row size and type (SDRAM).

When EDO DRAM is used, the 82443BX will open at most one page at a time. That is, one RAS# line will be asserted at any time. When SDRAM is used, either 2 or 4 pages can be open at any time within any row. If a row contains SDRAMs based on 16Mb technology (i.e., 12x8/9/10 devices) then two pages can be open at a time within that row. If a row contains SDRAMs based on 64Mb technology, (i.e., 14x8/9/10 devices) then four pages can be open at a time within that row.

This address multiplexing scheme is derived from Table 4-11 which depicts the addressing requirements for each of the row/column organizations for each row size. The SDRAM components used for the options shown in the table are as follows:

Option	SDRAM Component Type
2 (16MB)	2Mx8
3 (32MB)	4Mx16 or 4Mx4 (Registered DIMM only)
4 (64MB)	8Mx8
5 (128MB)	16Mx4 (Registered DIMM only)

Note: Both 4Mx4 and 16Mx4 SDRAM devices are supported in the form of Registered DIMMs only.

Table 4-10. Supported Memory Configurations

DRAM Attributes				DRAM DIMM		DRAM Addressing	MA			DRAM Size
Type	Tech	Depth	Width	SS x64	DS x64		Row	Col	Banks	Min (1 row)
EDO	4M	1M	4	1M	2M	Symmetric	10	10	NA	8 MB
		1M	4	1M	2M	Asymmetric	11	9	NA	8 MB
EDO	16M	2M	8	2M	4M	Asymmetric	11	10	NA	16 MB
		2M	8	2M	4M	Asymmetric	12	9	NA	16 MB
		2M	8	2M	4M	Asymmetric	13	8	NA	16 MB
		4M	4	4M	8M	Symmetric	11	11	NA	32 MB
		4M	4	4M	8M	Asymmetric	12	10	NA	32 MB
		4M	4	4M	8M	Asymmetric	14	8	NA	32 MB
EDO	64M	4M	16	4M	8M	Symmetric	11	11	NA	32 MB
		4M	16	4M	8M	Asymmetric	12	10	NA	32 MB
		4M	16	4M	8M	Asymmetric	14	8	NA	32 MB
		8M	8	8M	16M	Asymmetric	12	11	NA	64 MB
		16M	4	16M	32M	Symmetric	12	12	NA	128 MB
SDRAM	16M	2M	8	2M	4M	Asymmetric	12	9	2	16 MB
		2M	8	2M	4M	Asymmetric	13	8	2	16 MB
		4M	4	4M	8M	Asymmetric	12	10	2	32 MB
		4M	4	4M	8M	Asymmetric	14	8	2	32 MB
SDRAM	64M	4M	16	4M	8M	Asymmetric	14	8	4	32 MB
		8M	8	8M	16M	Asymmetric	14	9	4	64 MB
		16M	4	16M	32M	Asymmetric	14	10	4	128 MB

Table 4-11. MA Muxing vs. DRAM Address Split

	Split	Row/Col	SDRAM A11	BA1	BA0	A10/AP	A9	A8	A7	A6	A5	A4	A3	A2	A1	A0		
Option 1 8 MB	12x8*	Row			11	12	14	13	22	21	20	19	18	17	16	15		
		Col			11	AP			10	9	8	7	6	5	4	3		
	11x9	Row				12	14	13	22	21	20	19	18	17	16	15		
		Col						11	10	9	8	7	6	5	4	3		
	10x10	Row					14	13	22	21	20	19	18	17	16	15		
		Col					12	11	10	9	8	7	6	5	4	3		
	12x8	Row				11	12	14	13	22	21	20	19	18	17	16	15	
		Col							10	9	8	7	6	5	4	3		
	Option 2 16 MB	12x9*	Row			12	23	14	13	22	21	20	19	18	17	16	15	
			Col			12	AP		11	10	9	8	7	6	5	4	3	
		13x8*	Row			12	11	23	14	13	22	21	20	19	18	17	16	15
			Col			12	11	AP			10	9	8	7	6	5	4	3
11x10		Row				23	14	13	22	21	20	19	18	17	16	15		
		Col					12	11	10	9	8	7	6	5	4	3		
12x9		Row				12	23	14	13	22	21	20	19	18	17	16	15	
		Col						11	10	9	8	7	6	5	4	3		
13x8		Row			11	12	23	14	13	22	21	20	19	18	17	16	15	
		Col							10	9	8	7	6	5	4	3		
Option 3 32 MB		12x10*	Row			13	23	14	24	22	21	20	19	18	17	16	15	
			Col			13	AP	12	11	10	9	8	7	6	5	4	3	
	14x8*	Row	13	12	11	23	14	24	22	21	20	19	18	17	16	15		
		Col		12	11	AP			10	9	8	7	6	5	4	3		
	11x11	Row				23	14	24	22	21	20	19	18	17	16	15		
		Col				13	12	11	10	9	8	7	6	5	4	3		
	12x10	Row				13	23	14	24	22	21	20	19	18	17	16	15	
		Col					12	11	10	9	8	7	6	5	4	3		
	13x9	Row			12	13	23	14	24	22	21	20	19	18	17	16	15	
		Col							11	10	9	8	7	6	5	4	3	
	Option 4 64 MB	14x9*	Row	25	13	12	23	14	24	22	21	20	19	18	17	16	15	
			Col		13	12	AP		11	10	9	8	7	6	5	4	3	
13x10		Row		13	25	23	14	24	22	21	20	19	18	17	16	15		
		Col					12	11	10	9	8	7	6	5	4	3		
12x11		Row			25	23	14	24	22	21	20	19	18	17	16	15		
		Col				13	12	11	10	9	8	7	6	5	4	3		
Option 5 128 MB	14x10*	Row	25	14	13	23	26	24	22	21	20	19	18	17	16	15		
		Col		14	13	AP	12	11	10	9	8	7	6	5	4	3		
	13x11	Row		14	25	23	26	24	22	21	20	19	18	17	16	15		
		Col				13	12	11	10	9	8	7	6	5	4	3		
	12x12	Row			25	23	26	24	22	21	20	19	18	17	16	15		
		Col			14	13	12	11	10	9	8	7	6	5	4	3		

NOTE:

1. * Indicates SDRAM organization

4.3.3 SDRAMC Register Programming

Several timing parameters are programmable when using SDRAM in a Intel® 440BX AGPset system. The following table summarizes the programmable parameters.

Table 4-12. Programmable SDRAM Timing Parameters

Parameter	SDRAMC Bit	Values (DCLKs)
CAS# Latency	CL	2,3
RAS# to CAS# Delay	SRCD	2,3
RAS# Precharge	SRP	2,3
Leadoff CS# assertion	LCT	3,4

The 82443BX can support any combination of CAS# Latency, RAS# to CAS# Delay and RAS# Precharge. Two additional bits are provided for controlling CS# assertion. The first is the Leadoff Timing bits which effectively control when the command lines (SRAS#, SCAS# and WE#) are considered valid on the interface and hence when CS# can be asserted for CPU read leadoff cycles. In the fastest timing mode, CS# can be asserted in clock three. This enables a 7 clock page hit performance with CAS# Latency two devices and one clock MD to HD delay. This field controls when the first assertion of CS# occurs for read cycles initiated by the CPU. This assertion may be for a read, row activate or precharge command. The MA lines along with the command lines (SRAS#, SCAS# and WE#) are driven in clock two, however the clock to output delay timing is slower than the other modes. Use of this mode may require a lightly loaded SDRAM interface.

4.3.4 DRAMT Register Programming

Various EDO timing parameters are programmable in the 82443BX. The ranges provide support for the various loading configurations at 66 MHz. These are programmed via the DRAMT (DRAM Timing) register. Only 60 ns EDO DRAMs are supported and at 66 MHz only. Thus, certain parameters are fixed and are not programmable.

Table 4-13. EDO DRAM Timing Parameters

Parameter	60 ns EDO Spec (ns)	66 MHz CLKs
RAS# Precharge	40	3
RAS# Pulse Width	60	5
RAS# to CAS# Delay	20–45	3
CAS# Precharge	10	1
CAS# Pulse Width	15	1
WE# Setup to CAS# Falling	0	1
WE# Hold from CAS# Falling	10	1
MA Setup to RAS#/CAS#	0	1 or 2
MA Hold from RAS#/CAS#	10	1
MD Setup to CAS#	0	1
MD Hold from CAS#	10	1

4.3.5 SDRAM Paging Policy

Open page arbitration is a paging policy which leaves pages open when handing off ownership of DRAM among masters, and places no restrictions on the number of rows which may have open pages at any given time.

Features include:

- 1) Pipelined arbitration allows row/bank/page operations for next cycle to occur while current DRAM access is performed.
- 2) Maintaining 2, or 4 banks open at once, in up to 8 rows at a time.

4.4 PCI Interface

The 82443BX Host Bridge provides a PCI bus interface that is compliant with the PCI Local Bus Specification, Revision 2.1. The implementation is optimized for high-performance data streaming when the 82443BX is acting as either the target or the initiator on the PCI bus. The 82443BX supports the conventional PCI interface referred to as PCI and AGP/PCI interface referred to as AGP for PCI transactions and AGP for PCI transactions using the AGP enhanced protocols. AGP cycles using the enhanced protocols are non-snoopable cycles targeted at DRAM.

4.5 AGP Interface

The 82443BX Host Bridge provides a AGP bus interface that is compliant with the *A.G.P. Interface Specification, Revision 1.0*. The 82443BX supports AGP/PCI interface referred to as AGP for PCI transactions and AGP for PCI transactions using the AGP enhanced protocols.

4.6 Data Integrity Support

The 82443BX supports ECC (Error Checking and Correcting) or EC (Error Checking) data integrity modes on the 64-bit DRAM interface. The Intel® 440BX AGPset does not support the Pentium, Pro processor bus ECC protection. This mechanism is defined in the context of the Pentium Pro processor bus specification to support building of mission critical fault-tolerant systems. The ECC generation capability is essential for the high-end multiprocessor platforms where robustness of the system depends on the complexity of the routing of the Pentium Pro processor bus signals and operational bus frequency. UP/DP platforms based on the Intel® 440BX AGPset do not have the same requirements and therefore, the 82443BX does not support Pentium Pro processor bus ECC. Both the EC mode and the ECC mode are supported with either SDRAM or EDO DRAM.

4.6.1 Data Integrity Mode Selection

The 82443BX supports three modes of data integrity on the memory interface.

- No ECC with Byte-wise write support
- EC Mode (Error Checking only, no correction)
- ECC Mode (Error Checking and Correcting)

These modes are selected via the DRAM Data Integrity Mode (DDIM) field in the NBXCFG register.

4.6.1.1 Non-ECC (Default Mode of Operation)

After CPURST#, the 82443BX ECC control logic is set in the default mode, no data integrity or Non-ECC. This is the highest performance mode for the memory interface. Reads from memory are not delayed for error checking and correcting and writes of less than a QWord are performed without any overhead.

4.6.1.2 EC Mode

When the NBXCFG Register, bits 8:7 (DDIM) are set to 01, the 82443BX DRAM Controller is in EC mode. In this mode, the 82443BX external signals MECC[7:0] are driven with a protection code on writes and are checked with an internally generated code on reads. Writes of less than a QWord are performed as read-merge-write operations.

In EC mode, the 82443BX checks for errors on reads; however, it does not correct the data that is returned to the requesting agent. Also memory scrubbing is not performed. Note that the ECC code always protects or covers an entire QWord of data. When a write of less than a QWord is initiated, the QWord which is targeted by the write must be read, the new write data merged and the entire new QWord must then be written back to memory. Partial writes (writes of less than a QWord) are slowed since this read-merge-write operation is required.

4.6.1.3 ECC Mode

Selection between ECC and EC mode is performed entirely by software. If the system designer decides to select ECC protection for the 72-bit memory array (64bit memory data bus plus 8 ECC check bits), then MECC[7:0] signals carry ECC information to the 82443BX. The 82443BX generates/checks ECC as described in detail the following sections.

4.6.1.4 ECC Generation and Error Detection/Correction and Reporting

The 82443BX ECC logic implements the ECC code which is compatible with the algorithm used for the Pentium Pro processor data bus ECC protection. The code is described in the Pentium Pro processor bus specification.

ECC Generation

When enabled, the DRAM ECC mechanism allows automatic generation of an 8-bit protection code for the 64-bit (QWord) of data during DRAM write operations. If the originally requested write operation transfers single or multiple QWords, then the ECC-protected DRAM writes are completed with no overhead. That is, ECC code is calculated and written along with the data. If the originally requested write operation transfers less than 64bits of data (less than a QWord), then the 82443BX performs a READ-MERGE-WRITE operation.

ECC Checking and Correction

When enabled, the ECC mechanism allows a detection of single-bit and multiple-bit errors and recovery of single-bit errors. During DRAM read operations, a full QWord of data (8 bytes) is always transferred from DRAM to the 82443BX regardless of the size of the originally requested data. Both 64-bit data and 8-bit ECC code are transferred simultaneously from DRAM to the 82443BX. The ECC checking logic in the 82443BX generates a new ECC code for the received 64-bit data and compares it with received ECC code. If a single-bit error is detected the ECC logic generates a new "recovered" 64-bit QWord with a pattern which corresponds to the originally received 8-bit ECC protection code. The corrected data is returned to the requester (the CPU, PCI master or AGP master). Additionally, the 82443BX ensures that the data is corrected in main memory so that accumulation of errors is prevented. Another error within the same QWord would result in a double-bit error which is unrecoverable. This is known as hardware scrubbing since it requires no software intervention to correct the data in memory.

ECC Error Reporting

For single-bit error indication, the SEF flag is set by the 82443BX in the ERRSTS (Error Status) register, along with the row number associated with the first single-bit error. The row number where the error occurred is stored in the Single-bit First Row Error (SBFRE) field in the Error Status Register. Similarly, for multiple bit error indication, the MEF flag is set in the ERRSTS register along with the row number associated with the first multiple bit error. In the case of a multi-bit error the row number is stored in the Multi-bit First Row Error (MBFRE) field in the Error Status register. In both single-bit and multiple-bit error cases, after logging the first error, the Error Status register is locked until the software writes to the respective flags and clears the SEF and MEF bits. This error condition can also be optionally reported to the system via the SERR# mechanism. This functionality is controlled by the ERRCMD (Error Command) register. When bit 1 of the Error Command register is set to 1, an occurrence of a multiple bit error is signaled by the assertion of SERR#. When bit 0 of the Error Command register is set to 1, an occurrence of a single bit error is signaled by the assertion of SERR#. Reporting of single bit errors via SERR# is not critical since these errors are not only corrected as data is delivered to the requester and the error is automatically corrected in memory. However, system software may monitor the occurrence of single bit errors to indicate the presence of an unreliable DIMM when single bit errors frequently occur.

Note: Any ECC errors received during initialization should be ignored.

After a single-bit correctable ECC error has occurred, it is reported either via hardware mechanism or via software mechanism (periodic polling of the ERRSTS register). After a single bit error has occurred, the 82443BX then initiates a write to the location where the error occurred with the

corrected data. This feature is known as hardware scrubbing and eliminates the need for software scrubbing routines. Note that information in the ERRSTS register can be used later to point to a faulty DRAM DIMM if the single-bit errors continually occur during access to that DIMM.

Multi-bit uncorrectable errors are fatal system errors and will cause the 82443BX to assert the SERR# signal, if bit 1 of the ERRCMD register is set to 1. When an uncorrectable error is detected, the 82443BX will latch the row # where the error occurred Multi-bit First Row Error (MBFRE) bit in the ERRSTS register. This information can be used later to point to a faulty DRAM DIMM.

Note: When ECC is enabled, the whole DRAM array MUST be first initialized by doing writes before the DRAM read operations can be performed. This will establish the correlation between 64-bit data and associated 8-bit ECC code which does not exist after power-on.

4.6.1.5 Optimum ECC Coverage

Note that the 82443BX requirement is only that the memory array is 72 bits (64 bit memory data bus plus 8 ECC check bits) wide to select ECC or EC protection. The 82443BX does not assume any specific configuration or ordering of memory bits.

4.6.2 DRAM ECC Error Signaling Mechanism

When ECC is enabled and ERRCMD is used to set SERR# functionality, ECC errors are signaled to the system via the SERR# pin. The 82443BX can be programmed to signal SERR# on uncorrectable errors, correctable errors, or both. The type of error condition is latched until cleared by software (regardless of SERR# signaling).

When a single-bit error is detected, the offending DRAM row ID is latched in the Single-bit First Row Error (SBFRE) field in the ERRSTS register and the SEF (Single-bit Error Flag) bit is set to 1. The latched row value is held until software explicitly clears the error status flag (SEF bit). When a multiple-bit (uncorrectable) error is detected, the offending DRAM row ID is latched in the Multi-bit First Row Error (MBFRE) field in the ERRSTS register and the MEF (Multi-bit Error Flag) is set to 1. The latched row value is held until software explicitly clears the error status flag (MEF bit).

4.6.3 CPU Bus Integrity

The Intel® 440BX AGPset does not support the Pentium Pro processor bus integrity mechanisms. It does not provide support for data protection via ECC, and address/request signal protection via parity, nor does it support bus protocol error checking or reporting.

4.6.4 PCI Bus Integrity

The 82443BX implements Parity generation on the PAR pin as defined by the PCI Rev. 2.1 Specification for both Primary and Secondary PCI bus. The 82443BX does not contain the PERR# pin, however the 82443BX will check and report data parity errors on either the Primary or Secondary PCI buses. Data and address parity errors are reported on SERR#.

4.7 System Clocking

Figure 4-6 shows the clock architecture for a typical Intel® 440BX AGPset system.

Figure 4-6. Typical Intel® 440BX AGPset System Clocking

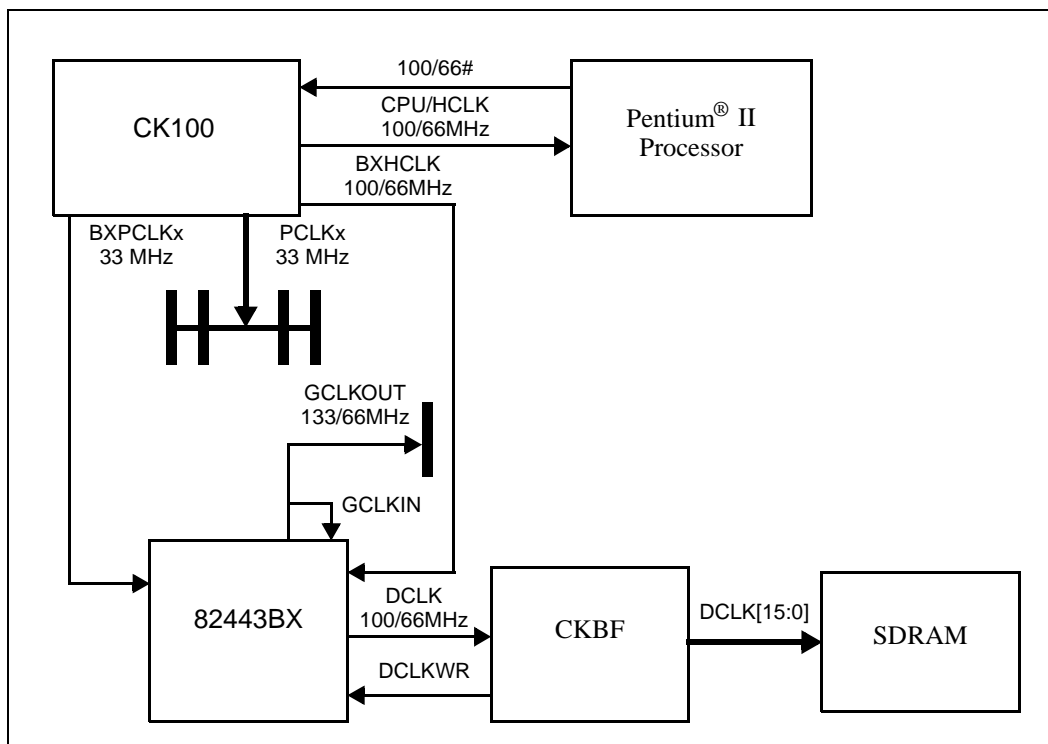

4.8 Power Management

This section focuses on the 82443BX power management features only. The PIIX4E datasheet along with this section provide the complete system power management description.

4.8.1 Overview

Power Management Features Supported by the 82443BX

- Suspend Resume
- Clock Control
- SDRAM Power Down Mode
- SMRAM
- ACPI and PCI-PM

Low-Power Modes Supported by the 82443BX

The 82443BX supports a variety of system-wide low power modes using the following functions:

- Hardware interface with PIIX4E is used to indicate:
 - Suspend mode entry.
 - Resume from suspend.
 - Whether to reset “resume logic” during resume from Suspend to Disk (STD).
 - Whether to automatically switch from suspend to normal refresh
- Automatic transition from normal to suspend refresh.
- Optional automatic transition from suspend to normal refresh.
- Optional CPU reset during resume from Power On Suspend (POS).
- Variety of Suspend refresh types:
 - Self Refresh for SDRAMs.
 - Optional Self Refresh for EDO.
 - Optional CAS Before RAS (CBR) refresh for EDO. Integrated Ring oscillator is used to provide the time base for the associated logic.
 - Programmable slow refresh, relevant for CBR refresh only.
- I/O pins isolation to significantly reduce power consumption while in POS and STR modes.

Based on the above functions, the 82443BX distinguishes the following system-wide low power modes:

- STR and POS suspend entry and exit are generally handled in the same manner. The following exceptions are related to POS:
 - POS resume sequence may or may not include CPU reset. STR, with PCIRST# active always includes CPU reset.
 - POS resume sequence requires hardware transition from suspend to normal refresh. STR, with PCIRST# active requires software initiated transition.
- STD resume is handled the same as power on sequence, including complete reset of 82443BX state.

Clock Control Functions Supported by 82443BX

- Internal clock gating: this function allows the 82443BX to gate the clock to the majority of its logic while there is no pending events to handle.
- The Primary PCI bus includes the support of the CLKRUN#, which enables the PIIX4E to dynamically disable the primary PCICLK and for the 82443BX and PCI peripheral to re-enable the clock when it is needed to perform a transaction.
- When an AGP port is not available on the system, a strapping option allows the 82443BX to permanently disable all clocks associated with AGP logic.

SDRAM Power Down Mode

The 82443BX supports SDRAM power down mode. The 82443BX also provides a capability to dynamically enter the SDRAM into low power mode when DRAM rows are idle and resume DRAM activity when transactions request the access to DRAM.

SMRAM Functions

The 82443BX provides the normal SMRAM range mapping, in the areas below 1MB, as well as extended SMRAM ranges that are mapped in cacheable ranges above 1MB. In addition, the 82443BX provides the normal control mechanism to initialize, close for data accesses and lock the SMRAM range.

Summary of ACPI Functions

The 82443BX provides an optional decoding of pm2_control register in IO port 22h. This IO port can be used to disable the 82443BX arbiters for PCI and AGP initiated cycles.

Desktop vs. Mobile Power Management Functions

In general, all mobile functions of the 82443BX are available in the desktop configuration. Due to system design limitations, however, certain functions are not supported in a desktop environment (i.e., POS/C3 state).

In Mobile systems, when system exits low power modes such as deep sleep or POS, the AGP devices should not generate a request, using AGP semantics, for a duration of at least 33 usec.

System Power Modes

Table 4-14 provides an overview of how the above features map into system-wide low power modes.

Table 4-14. Low Power Mode

System Suspend State	82443BX State	Description	POS Exit PCIRST	External Clk HCLK PCLK	
				HCLK	PCLK
Powered-On	ON	The 82443BX is fully on and operating normally. Internal clock gating as well as PCI CLKRUN# may be enabled.	N/A	Active	Active
CPU STOP_GRANT / QUICK_START (C2)	ON	This is transparent to the 82443BX as external HCLK and PCLK are unaffected. Host Bus is Idle however. Internal clock gating as well as PCI CLKRUN# may be enabled.	N/A	Active	Active
CPU STOP CLOCK (C3) (DEEP SLEEP)	POS	HCLK clock is kept low. The 82443BX maintains DRAM refresh using suspend refresh.	N	Low	Low or Active
Powered On Suspend (POS, POSCL)	POS	The only running clock is the RTC clock. The 82443BX maintains DRAM refresh using suspend refresh. When resume, the 82443BX may or may not generate CPU reset.	N	Low	Low
Powered On Suspend (POSCL)		The only running clock is the RTC clock. The 82443BX maintains DRAM refresh using suspend refresh. On resume, PIIX4E generates PCI reset.	Y	Low	Low
Suspend to RAM (STR)	POS	CPU and other components (with the exception of DRAM and PIIX4E resume logic) are assumed to be powered OFF. The 82443BX maintains DRAM refresh using suspend refresh. All 82443BX logic, with the exception of resume and refresh are inactive.	Y	Low	Low
Suspend -to-Disk (STD) or Powered-Off	OFF	Entire system is powered OFF except for PIIX4E resume and RTC wells. Upon resume, the 82443BX resets its entire state.	N/A	X	X

4.8.2 82443BX Reset

The 82443BX reset function is an integral part of the suspend resume functions. The 82443BX supports the normal reset function in a desktop platform, as well as the various power-up reset and resume reset functions in the mobile platform. In this section, the power-up reset is described. The resume from suspend sequences are described in the following section.

Table 4-15. AGPset Reset

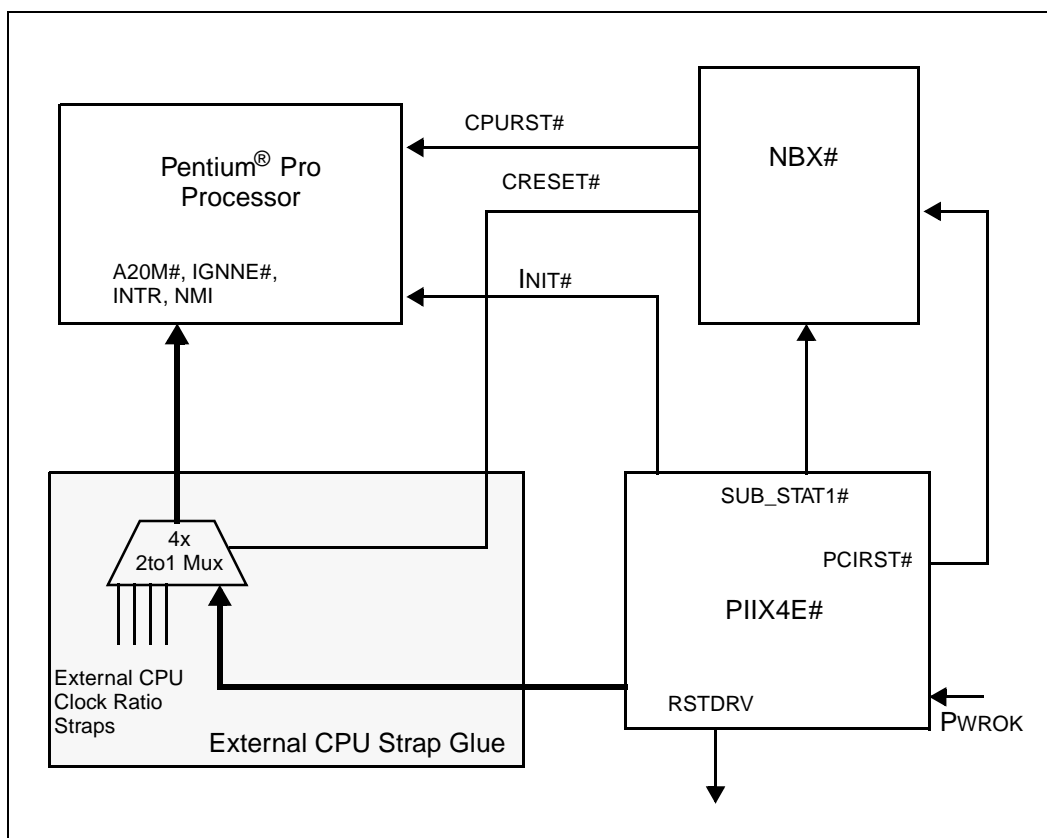

Table 4-16. Reset Signals

Signal	Asserted with PCIRST#	System Devices or Buses Affected	Signal Source	Description
PCIRST#	-	PCI bus, 82443BX NB, PIIX4E	PIIX4E	PCIRST# is used in power -up sequence as well as resume from STR or STD.
CPURST#	Always	CPU	82443BX	CPU reset signal. CPURST# pin resides in 82443BX.
RSTDRV	Always	ISA bus / X-Bus devices	PIIX4E	ISA bus reset. Directly derived from PCIRST#. Resides in PIIX4E main voltage well.
SUS_STAT#	N/A		PIIX4E only	SUS_STAT# signals a suspend mode entry and exit. Both signals originate from PIIX4E in its suspend voltage well.
INIT#	No	CPU	PIIX4E	CPU Soft Reset generated by PIIX4E.

4.8.2.1 CPU Reset

The CPU reset is generated by the 82443BX in the following case:

- CPURST# is always asserted if PCIRST# is asserted.
- CPURST# is asserted during resume sequence from POS **CRst_En= 1**.

The 82443BX deasserts CPURST# 1 ms after detecting the rising edge of PCIRST#. The CPURST# is synchronous to host bus clock.

Figure 4-7. Reset CPURST# in a Desktop or Mobile System When PCIRST# Asserted

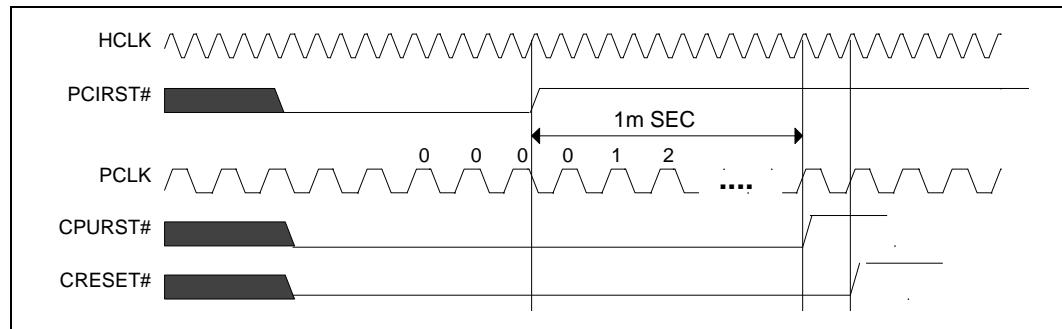

PCIRST# must be asserted when the system resumes from low power mode of which power is removed, including resume from STR or STD and power up sequence. In these cases, CPURST# is activated with the assumption that CPU power is removed as well and in order to enforce correct resume sequence.

When resuming from POS, the PCIRST# and CPURST# are typically not used, to speed up the resume sequence. The option to reset the CPU, in this case, is available by using the CRst_En configuration bit option.

When the user performs a soft reset, the PIIX4E drives SUSTAT# to the 82443BX. This forces the 82443BX to switch to a suspend refresh state. When the BIOS attempts to execute cycles to DRAM, the 82443BX will not accept these cycles because it believes that it is in a suspend state. After coming out of reset, software must set the Normal refresh enable bit (bit4, Power Management Control register at Offset 7Ah) in the 82443BX before doing an access to memory.

4.8.2.2 CPU Clock Ratio Straps

The Pentium Pro processors require their internal clock ratio to be set up via strapping pins multiplexed onto signals A20M#, IGNE#, INTR, and NMI. These signals should reflect the strapping values during the deasserted edge of CPURST# signal and be held stable for between 2 to 20 clocks. HCLKs after CPURST# is deasserted.

The 82443BX is designed to support CPU strapping options with external logic, when PIIX4E is used. Figure 4-8 illustrates the strapping pin timing when using the external glue logic (necessary for PIIX4E). The external mux is switched via the CRESET# signal which is a 2 clock delayed version of CPURST#.

Figure 4-8. External Glue Logic Drives CPU Clock Ratio Straps

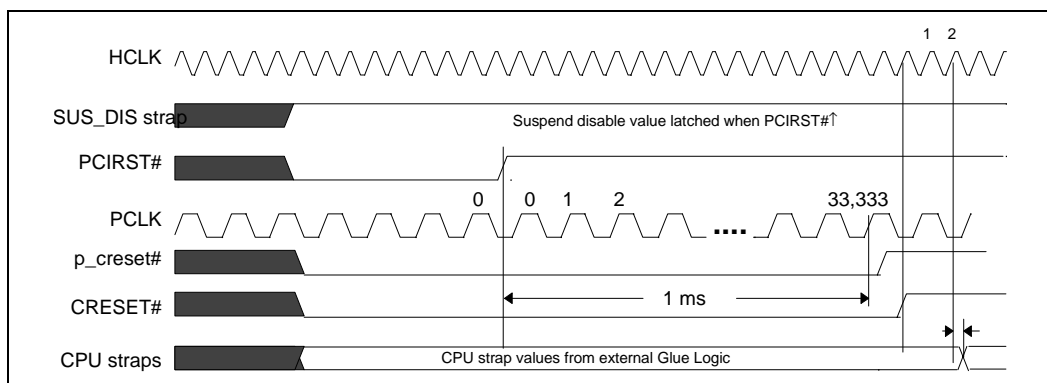

4.8.2.3 82443BX Straps

The 82443BX strapping options are latched in the rising edge of PCIRST#.

4.8.3 Suspend Resume

4.8.3.1 Suspend Resume protocols

The suspend resume sequences are indicated to the 82443BX by the PIIX4E, using SUS_STAT#, and PCIRST#. In addition, the 82443BX contains NREF_EN and Crst_En configuration bits that participate in the suspend resume sequences. As a result of suspend resume, the 82443BX performs the following activities: Changing its refresh mode, performing internal and CPU reset and Isolate or re-enable normal IO buffers.

Table 4-17. Suspend / Resume Events and Activities

State	SUSTAT#	PCIRST#	CrstEn	RESET	REFRESH	IO BUFFERS
ON	assert	inactive	-	-	switch to suspend refresh	isolate
POSCL/STR	deassert	active	-	reset exclude resume/ref logic	suspend refresh NREF_EN remains inactive	enable
POS	deassert	inactive	0	no resets	auto switch to normal ref NREF_EN is set	enable
POSCCL	deassert	inactive	1	reset CPU only	auto switch to normal ref NREF_EN is set	enable

4.8.3.2 Suspend Refresh

Suspend Refresh Modes

The 82443BX supports suspend refresh by providing a mechanism to transition in and out of suspend. The supported suspend refresh types are:

- Self Refresh when SDRAM are used
- Self Refresh when EDO -DRAMs are used
- CBR Refresh when EDO-DRAMs are used

SDRAM Suspend Refresh

When the 82443BX is configured for 3 DIMMs, six CKE signals are provided. When the 82443BX is configured for 4 DIMMs, a single GCKE (global CKE) is provided to allow an external device to correctly drive the external CKE signals to the SDRAM devices. An additional 3 DIMM configuration is where only CKE0 is provided. A detailed description of the DRAM signal functions is given in the Chapter 2, “Signal Description”.

For the Registered DIMMs the CKE function is not supported. The stacking technology used for registered DIMMs prohibits the use of the CKE function. For registered DIMMs, components are stacked on top of one another. The stacked components are **physically** in the same row, but **logically** in separate rows. The stacked components connect all pins together, except for the CS# pin, in order to address components in different rows. Since the CKE pins for the components are connected together, and the components are **logically** in different rows, the CKE function is not supported.

Table 4-18. SDRAM Suspend Refresh Configuration Modes

MM CONFIG	SDRAM PWR	FUNCTION
0	0	3 DIMM, CKE[5:0] driven, self-refresh entry staggered. SDRAM dynamic power down available.
1	X	3 DIMM, CKE0 only, self-refresh entry not staggered. SDRAM dynamic power down unavailable.
0	1	4 DIMM, GCKE only, self-refresh entry staggered. SDRAM dynamic power down unavailable.

EDO DRAM Suspend Refresh

The 82443BX NB supports two modes of EDO refresh during suspend: CAS-before-RAS and Self-refresh. The refresh mode is dependent on the Suspend Refresh type bit (SRT) in the Miscellaneous Control Register.

4.8.4 Clock Control Functions

The 82443BX implements an independent Clock Gating power savings feature to reduce its own average power consumption. The 82443BX clock gating functions works along with the primary PCI bus CLKRUN# function.

The Clock Gating function is enabled by setting the GCLKEN Configuration bit. This function default value is 0. The AGP interface’s clock domain can be permanently disabled by the AGP_DIS configuration bit. This allows further power savings in systems that AGP is not used.

CLKRUN Clocking States

There are three states in the CLKRUN# protocol:

- **Clock Running:** The clock is running and the bus is operational.
- **Clock Stop Request:** The central resource has indicated on the CLKRUN# line that the clock is about to stop.
- **Clock Stopped:** The clock is stopped with CLKRUN# being monitored for a restart.

4.8.5 SDRAM Power Down Mode

The 82443BX supports a SDRAM power down mode to minimize SDRAM power usage. The 82443BX controls the SDRAM power mode per row, when all banks in a given row are idle, the associated CKE signal is deasserted. When a powered down row address is requested, the associated CKE is asserted.

4.8.6 SMRAM

SMRAM ranges

The 82443BX supports the use of main memory as System Management RAM (SMRAM) enabling the use of System Management Mode. There are two SMRAM options: Compatible SMRAM (C_SMRAM) and Extended SMRAM (E_SMRAM). System Management RAM (SMRAM) space provides a memory area that is available for the SMI handler's and code and data storage. This memory resource is normally hidden from the operating system so that the processor has immediate access to this memory space upon entry to SMM. 82443BX provides three SMRAM options:

- Below 1 MB option that supports compatible SMI handlers.
- Above 1 MB option that allows new SMI handlers to execute with write-back cacheable SMRAM.
- Optional larger write-back cacheable T_SEG area from 128KB to 1MB in size above 1 MB that is reserved from the highest area in system DRAM memory. The above 1 MB solutions require changes to compatible SMRAM handlers code to properly execute above 1 MB.

Compatible SMRAM (C_SMRAM)

This is the traditional SMRAM feature supported in Intel AGPsets. When this function is enabled via C_BASE_SEG[2:0]=010 and G_SMRAME=1 of the SMRAMC register, the 82443BX reserves 000A0000h through 000BFFFFh (A and B segments) of the main memory for use as non-cacheable SMRAM.

The SMI handler can set the CLS bit to enable data accesses to aliased memory space, while code fetches access the SMRAM space.

Extended SMRAM (E_SMRAM)

This feature in the 82443BX extend the SMRAM space up to 1 MB and provide write-back cacheability.

The TSEG size is 128 KBs, 256 KBs, 512 KBs or 1 MB, as defined by TSEG_SZ[1:0] of the SMRAMC register.

The CPU can access these memory ranges by one of the following mechanisms:

- The processor can access SMRAM while in the SMM mode. A processor access to while not in SMM and with while the D_OPN bit is reset will be forwarded to PCI bus and a status bit is set in the SMRAMC register.
- The processor can access SMRAM while the D_OPN bit is set.

Pinout and Package Information 5

5.1 82443BX Pinout

Figure 5-1 and Figure 5-2 show the ball footprint of the 82443BX package. These figures represent the pinout by ball number. For an alphabetical list of the pinout by signal name refer to Table 5-1.

Figure 5-1. 82443BX Pinout (Top View–left side)

	1	2	3	4	5	6	7	8	9	10	11	12	13
A	VSS	AD20	PCIRST#	AD25	AD29	PREQ0#	HD56#	HD62#	HD55#	HD54#	HD49#	HD47#	HD40#
B	VCC	PCLKIN	AD22	AD27	AD28	PHOLD#	HD50#	HD61#	HD63#	HD53#	HD48#	HD42#	HD36#
C	AD19	REFVCC	AD21	C/BE3#	VSS	AD31	PREQ1#	HD52#	VSS	HD60#	HD59#	HD51#	HD44#
D	AD16	AD18	AD17	AD23	AD26	PHLDA#	PGNT1#	PREQ3#	HD58#	PREQ4#	HD46#	HD41#	HD39#
E	IRDY#	FRAME#	VSS	C/BE2#	AD24	AD30	PGNT0#	PGNT3#	PGNT4#	PGNT2#	HD57#	VSS	HD45#
F	SERR#	PLOCK#	DEVSEL#	STOP#	TRDY#	VSS	VCC	VSS	VCC	PREQ2#			
G	AD13	AD14	C/BE1#	AD15	PAR	VCC							
H	AD8	AD7	AD10	AD12	AD11	VSS							
J	AD5	AD6	VSS	C/BE0#	AD9	VCC							
K	SBA0	AD1	AD3	AD2	AD4	AD0							
L	ST2	ST1	GGNT#	ST0	GREQ#						VCC	VSS	VCC
M	SBA2	SBA1	PIPE#	RBF#	VSS						VSS	VCC	VSS
N	VSS	SBA3	SBSTB	AGPREF	GCLKIN						VCC	VSS	VSS
P	VCC	SBA4	SBA6	SBA5	GCLKO						VCC	VSS	VSS
R	SBA7	GAD31	GAD29	GAD30	VSS						VSS	VCC	VSS
T	GAD27	GAD26	GAD24	GAD25	ADSTB_B						VCC	VSS	VCC
U	GAD23	GC/BE3#	GAD22	GAD21	GAD19	GAD28							
V	GAD20	GAD17	VSS	GC/BE2#	GIRDY#	VCC							
W	GAD16	GAD18	GFRAME#	GTRDY#	GDEVSEL#	VSS							
Y	GSTOP#	GPAR	GAD15	GC/BE1#	GAD14	VCC							
AA	GAD13	GAD12	GAD10	GAD11	GAD9	VSS	VCC	VSS	VCC	MECC1			
AB	GAD8	GC/BE0#	VSS	GAD7	GAD0	MD34	MD5	MD8	MD9	MD12	MD46	VSS	SCASB#
AC	GAD6	ADSTB_A	GAD5	CLKRUN#	MD32	MD35	MD6	MD39	MD10	MD13	MD47	WEB#	DQMA1
AD	GAD4	GAD3	GAD2	SUSTAT#	VSS	MD3	MD37	MD40	VSS	MD44	MD15	MECC5	DQMA0
AE	VCC	GAD1	WSC#	MD1	MD33	MD4	MD38	MD42	MD11	MD45	MECC0	WEA#	DQMB1
AF	VSS	VCC	BXPWROK	MD0	MD2	MD36	MD7	MD41	MD43	MD14	MECC4	SCASA#	VSS

NOTES:

- The following signals are multiplexed. See the following Alphabetical pin list for details.
 - CSA[5:0]# is multiplexed with RASA[5:0]#; CSB[5:0]# is multiplexed with RASB[5:0]#
 - CKE[3:2] is multiplexed with CSA[7:6]#; CKE[5:4] is multiplexed with CSB[7:6]#; CKE1 is multiplexed with GCKE; CKE0 is multiplexed with FENA
 - DQMA[7:0] is multiplexed with CASA[7:0]#; DQMB[5,1] is multiplexed with CASB[5,1]#

Figure 5-2. 82443BX Pinout (Top View–right side)

14	15	16	17	18	19	20	21	22	23	24	25	26	
VSS	HD33#	HD31#	HD27#	HD19#	HD20#	HD10#	HD6#	HD3#	HA29#	HA24#	HA22#	VSS	A
HD43#	HD32#	HD29#	HD25#	HD21#	HD18#	HD12#	HD8#	HD0#	CPURST#	HA27#	HA20#	BREQ0#	B
HD37#	HD28#	HD26#	HD22#	VSS	HD17#	HD7#	HD5#	VSS	HA26#	HA28#	HA23#	HA21#	C
HD34#	HD35#	HD30#	HD24#	HD16#	HD15#	HD14#	HD4#	HD1#	HA31#	HA25#	HA18#	HA19#	D
HD38#	VSS	GTLREFB	HD23#	HD13#	HD11#	HD9#	HD2#	HA30#	HA15#	VSS	HA17#	HA16#	E
			VTTB	VCC	VSS	VCC	VSS	HA11#	HA12#	HA13#	HA14#	HA8#	F
							VCC	HA10#	HA5#	HA7#	HA3#	HA9#	G
							VSS	HA4#	HA6#	BNR#	HTRDY#	BPRI#	H
							VCC	HREQ0#	HREQ1#	VSS	HREQ4#	DEFER#	J
							ADS#	HLOCK#	DRDY#	HREQ2#	HREQ3#	RS0#	K
								HITM#	DBSY#	HIT#	RS2#	RS1#	L
								VSS	GTLREFA	VTTA	TESTIN#	CRESET#	M
								VCC	HCLKIN	VSS	MD31	VCC	N
								NC	MD30	MD62	MD63	VSS	P
								VSS	MD60	MD28	MD29	MD61	R
								MD25	MD26	MD57	MD58	MD27	T
							MD59	MD54	MD24	MD23	MD55	MD56	U
							VCC	MD51	MD52	VSS	MD53	MD22	V
							VSS	MD50	MD18	MD19	MD21	MD20	W
							VCC	MECC7	MD48	MD16	MD17	MD49	Y
			SRASB#	VCC	VSS	VCC	VSS	DQMA6	MECC2	DQMA7	MECC6	MECC3	AA
CSA0#	VSS	MAA1	MAB3#	MAB6#	MAB7#	MAB10	DCLKO	NC	CSB5#	VSS	VSS	DQMA3	AB
DQMA5	CSA3#	MAB1#	MAA3	MAA7	MAA8	MAB9#	MAA12	CKE0	CKE4	CSB3#	DQMA2#	CSB4#	AC
DQMB5	CSA4#	MAB0#	MAB2#	VSS	MAB5#	MAA10	MAB12#	VSS	CKE3	CSB1#	DCLKWR	CSB2#	AD
DQMA4	CSA2#	CSA5#	MAA2	MAB4#	MAA5	MAA9	MAB11#	NC	NC	CKE2	CSB0#	VCC	AE
VCC	CSA1#	SRASA#	MAA0	MAA4	MAA6	MAB8#	MAA11	MAB13	CKE1	CKE5	MAA13	VSS	AF

VCC	VSS	VCC
VSS	VCC	VSS
VSS	VSS	VCC
VSS	VSS	VCC
VSS	VCC	VSS
VCC	VSS	VCC

NOTES:

1. The following signals are multiplexed. See the following Alphabetical pin list for details.
 - d. CSA[5:0]# is multiplexed with RASA[5:0]#; CSB[5:0]# is multiplexed with RASB[5:0]#
 - e. CKE[3:2] is multiplexed with CSA[7:6]#; CKE[5:4] is multiplexed with CSB[7:6]#; CKE1 is multiplexed with GCKE; CKE0 is multiplexed with FENA
 - f. DQMA[7:0] is multiplexed with CASA[7:0]#; DQMB[5,1] is multiplexed with CASB[5,1]#

Table 5-1. 82443BX Alphabetical BGA Pin List (Sheet 1 of 4)

Signal Name	Pin	Signal Name	Pin	Signal Name	Pin
AD0	K6	C/BE2#	E4	GAD0	AB5
AD1	K2	C/BE3#	C4	GAD1	AE2
AD2	K4	CKE0/FENA	AC22	GAD2	AD3
AD3	K3	CKE1/GCKE	AF23	GAD3	AD2
AD4	K5	CKE2/CSA6	AE24	GAD4	AD1
AD5	J1	CKE3/CSA7	AD23	GAD5	AC3
AD6	J2	CKE4/CSB6	AC23	GAD6	AC1
AD7	H2	CKE5/CSB7	AF24	GAD7	AB4
AD8	H1	CLKRUN#	AC4	GAD8	AB1
AD9	J5	CPURST#	B23	GAD9	AA5
AD10	H3	CRESET#	M26	GAD10	AA3
AD11	H5	CSA0#/RASA0#	AB14	GAD11	AA4
AD12	H4	CSA1#/RASA1#	AF15	GAD12	AA2
AD13	G1	CSA2#/RASA2#	AE15	GAD13	AA1
AD14	G2	CSA3#/RASA3#	AC15	GAD14	Y5
AD15	G4	CSA4#/RASA4#	AD15	GAD15	Y3
AD16	D1	CSA5#/RASA5#	AE16	GAD16	W1
AD17	D3	CSB0#/RASB0#	AE25	GAD17	V2
AD18	D2	CSB1#/RASB1#	AD24	GAD18	W2
AD19	C1	CSB2#/RASB2#	AD26	GAD19	U5
AD20	A2	CSB3#/RASB3#	AC24	GAD20	V1
AD21	C3	CSB4#/RASB4#	AC26	GAD21	U4
AD22	B3	CSB5#/RASB5#	AB23	GAD22	U3
AD23	D4	DBSY#	L23	GAD23	U1
AD24	E5	DCLKO	AB21	GAD24	T3
AD25	A4	NC	AB22	GAD25	T4
AD26	D5	DCLKWR	AD25	GAD26	T2
AD27	B4	DEFER#	J26	GAD27	T1
AD28	B5	DEVSEL#	F3	GAD28	U6
AD29	A5	DQMA0/CASA0#	AD13	GAD29	R3
AD30	E6	DQMA1/CASA1#	AC13	GAD30	R4
AD31	C6	DQMA2/CASA2#	AC25	GAD31	R2
ADS#	K21	DQMA3/CASA3#	AB26	GC/BE0#	AB2
ADSTB_A	AC2	DQMA4/CASA4#	AE14	GC/BE1#	Y4
ADSTB_B	T5	DQMA5/CASA5#	AC14	GC/BE2#	V4
AGPREF	N4	DQMA6/CASA6#	AA22	GC/BE3#	U2
BNR#	H24	DQMA7/CASA7#	AA24	GCLKIN	N5
BPRI#	H26	DQMB1/CASB1#	AE13	GCLKO	P5
BREQ0#	B26	DQMB5/CASB5#	AD14	GDEVSEL#	W5
C/BE0#	J4	DRDY#	K23	GFRAME#	W3
C/BE1#	G3	FRAME#	E2	GGNT#	L3

Table 5-1. 82443BX Alphabetical BGA Pin List (Sheet 2 of 4)

Signal Name	Pin	Signal Name	Pin	Signal Name	Pin
GIRDY#	V5	HD4#	D21	HD45#	E13
GPAR	Y2	HD5#	C21	HD46#	D11
GREQ#	L5	HD6#	A21	HD47#	A12
GSTOP#	Y1	HD7#	C20	HD48#	B11
GTLREFA	M23	HD8#	B21	HD49#	A11
GTLREFB	E16	HD9#	E20	HD50#	B7
GTRDY#	W4	HD10#	A20	HD51#	C12
HA3#	G25	HD11#	E19	HD52#	C8
HA4#	H22	HD12#	B20	HD53#	B10
HA5#	G23	HD13#	E18	HD54#	A10
HA6#	H23	HD14#	D20	HD55#	A9
HA7#	G24	HD15#	D19	HD56#	A7
HA8#	F26	HD16#	D18	HD57#	E11
HA9#	G26	HD17#	C19	HD58#	D9
HA10#	G22	HD18#	B19	HD59#	C11
HA11#	F22	HD19#	A18	HD60#	C10
HA12#	F23	HD20#	A19	HD61#	B8
HA13#	F24	HD21#	B18	HD62#	A8
HA14#	F25	HD22#	C17	HD63#	B9
HA15#	E23	HD23#	E17	HIT#	L24
HA16#	E26	HD24#	D17	HITM#	L22
HA17#	E25	HD25#	B17	HLOCK#	K22
HA18#	D25	HD26#	C16	HREQ0#	J22
HA19#	D26	HD27#	A17	HREQ1#	J23
HA20#	B25	HD28#	C15	HREQ2#	K24
HA21#	C26	HD29#	B16	HREQ3#	K25
HA22#	A25	HD30#	D16	HREQ4#	J25
HA23#	C25	HD31#	A16	HTRDY#	H25
HA24#	A24	HD32#	B15	IRDY#	E1
HA25#	D24	HD33#	A15	MAA0	AF17
HA26#	C23	HD34#	D14	MAA1	AB16
HA27#	B24	HD35#	D15	MAA2	AE17
HA28#	C24	HD36#	B13	MAA3	AC17
HA29#	A23	HD37#	C14	MAA4	AF18
HA30#	E22	HD38#	E14	MAA5	AE19
HA31#	D23	HD39#	D13	MAA6	AF19
HCLKIN	N23	HD40#	A13	MAA7	AC18
HD0#	B22	HD41#	D12	MAA8	AC19
HD1#	D22	HD42#	B12	MAA9	AE20
HD2#	E21	HD43#	B14	MAA10	AD20
HD3#	A22	HD44#	C13	MAA11	AF21

Table 5-1. 82443BX Alphabetical BGA Pin List (Sheet 3 of 4)

Signal Name	Pin	Signal Name	Pin	Signal Name	Pin
MAA12	AC21	MD25	T22	MECC2	AA23
MAA13	AF25	MD26	T23	MECC3	AA26
MAB0#	AD16	MD27	T26	MECC4	AF11
MAB1#	AC16	MD28	R24	MECC5	AD12
MAB2#	AD17	MD29	R25	MECC6	AA25
MAB3#	AB17	MD30	P23	MECC7	Y22
MAB4#	AE18	MD31	N25	NC	P22
MAB5#	AD19	MD32	AC5	NC	AE22
MAB6#	AB18	MD33	AE5	NC	AE23
MAB7#	AB19	MD34	AB6	PAR	G5
MAB8#	AF20	MD35	AC6	PCIRST#	A3
MAB9#	AC20	MD36	AF6	PCLKIN	B2
MAB10	AB20	MD37	AD7	PGNT0#	E7
MAB11#	AE21	MD38	AE7	PGNT1#	D7
MAB12#	AD21	MD39	AC8	PGNT2#	E10
MAB13	AF22	MD40	AD8	PGNT3#	E8
MD0	AF4	MD41	AF8	PGNT4#	E9
MD1	AE4	MD42	AE8	PHLDA#	D6
MD2	AF5	MD43	AF9	PHOLD#	B6
MD3	AD6	MD44	AD10	PIPE#	M3
MD4	AE6	MD45	AE10	PLOCK#	F2
MD5	AB7	MD46	AB11	PREQ0#	A6
MD6	AC7	MD47	AC11	PREQ1#	C7
MD7	AF7	MD48	Y23	PREQ2#	F10
MD8	AB8	MD49	Y26	REQ3#	D8
MD9	AB9	MD50	W22	PREQ4#	D10
MD10	AC9	MD51	V22	RBF#	M4
MD11	AE9	MD52	V23	REFVCC	C2
MD12	AB10	MD53	V25	RS0#	K26
MD13	AC10	MD54	U22	RS1#	L26
MD14	AF10	MD55	U25	RS2#	L25
MD15	AD11	MD56	U26	SBSTB	N3
MD16	Y24	MD57	T24	SBA0	K1
MD17	Y25	MD58	T25	SBA1	M2
MD18	W23	MD59	U21	SBA2	M1
MD19	W24	MD60	R23	SBA3	N2
MD20	W26	MD61	R26	SBA4	P2
MD21	W25	MD62	P24	SBA5	P4
MD22	V26	MD63	P25	SBA6	P3
MD23	U24	MECC0	AE11	SBA7	R1
MD24	U23	MECC1	AA10	SCASA#	AF12

Table 5-1. 82443BX Alphabetical BGA Pin List (Sheet 4 of 4)

Signal Name	Pin	Signal Name	Pin	Signal Name	Pin
SCASB#	AB13	VCC	V21	VSS	N14
SERR#	F1	VCC	Y6	VSS	N15
SRASA#	AF16	VCC	Y21	VSS	N24
SRASB#	AA17	VCC	AA7	VSS	P12
ST0	L4	VCC	AA9	VSS	P13
ST1	L2	VCC	AA18	VSS	P14
ST2	L1	VCC	AA20	VSS	P15
STOP#	F4	VCC	AE1	VSS	P26
BXPWROK	AF3	VCC	AE26	VSS	R5
SUSTAT#	AD4	VCC	AF2	VSS	R11
TESTIN#	M25	VCC	AF14	VSS	R13
TRDY#	F5	VSS	A1	VSS	R14
VCC	B1	VSS	A14	VSS	R16
VCC	F7	VSS	A26	VSS	R22
VCC	F9	VSS	C5	VSS	T12
VCC	F18	VSS	C9	VSS	T15
VCC	F20	VSS	C18	VSS	V3
VCC	G6	VSS	C22	VSS	V24
VCC	G21	VSS	E3	VSS	W6
VCC	J6	VSS	E12	VSS	W21
VCC	J21	VSS	E15	VSS	AA6
VCC	L11	VSS	E24	VSS	AA8
VCC	L13	VSS	F6	VSS	AA19
VCC	L14	VSS	F8	VSS	AA21
VCC	L16	VSS	F19	VSS	AB3
VCC	M12	VSS	F21	VSS	AB12
VCC	M15	VSS	H6	VSS	AB15
VCC	N11	VSS	H21	VSS	AB24
VCC	N16	VSS	J3	VSS	AB25
VCC	N22	VSS	J24	VSS	AD5
VCC	N26	VSS	L12	VSS	AD9
VCC	P1	VSS	L15	VSS	AD18
VCC	P11	VSS	M5	VSS	AD22
VCC	P16	VSS	M11	VSS	AF1
VCC	R12	VSS	M13	VSS	AF13
VCC	R15	VSS	M14	VSS	AF26
VCC	T11	VSS	M16	VTTA	M24
VCC	T13	VSS	M22	VTTB	F17
VCC	T14	VSS	N1	WEA#	AE12
VCC	T16	VSS	N12	WEB#	AC12
VCC	V6	VSS	N13	WSC#	AE3

5.2 Package Dimensions

This specification outlines the mechanical dimensions for the 82443BX Host Bridge. The package is a 492 ball grid array (BGA).

Figure 5-3. 82443BX BGA Package Dimensions—Top and Side Views

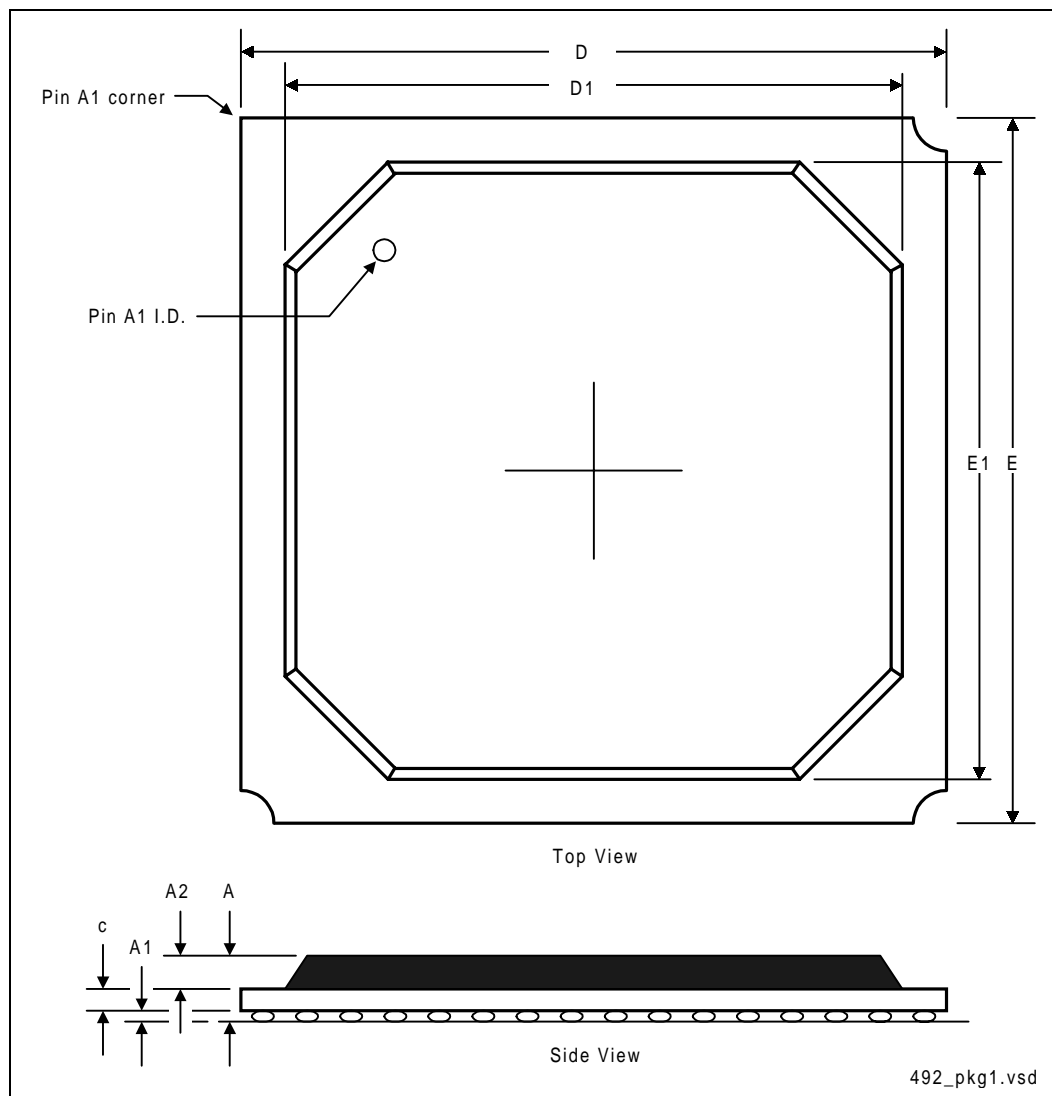

Figure 5-4. 82443BX BGA Package Dimensions—Bottom Views

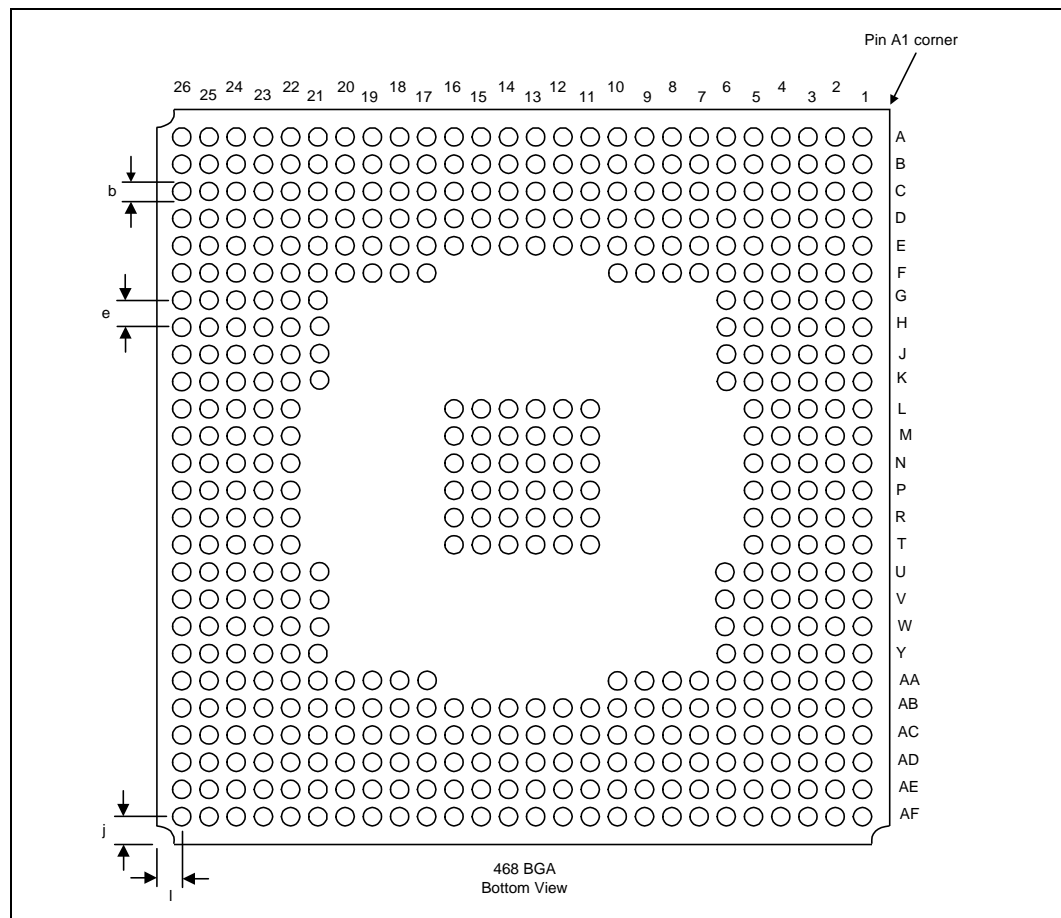

Table 5-2. 82443BX Package Dimensions (492 BGA)

Symbol	e=1.27 mm (solder ball pitch)			Note
	Min	Nominal	Max	
A	2.17	2.38	2.59	
A1	0.50	0.60	0.70	
A2	1.12	1.17	1.22	
D	34.80	35.00	35.20	
D1	29.75	30.00	30.25	
E	34.80	35.00	35.20	
E1	29.75	30.00	30.25	
I	1.63 REF.			
J	1.63 REF.			
M	26 x 26 Matrix			
N	4.92			
b	0.60	0.75	0.90	
c	0.55	0.61	0.67	

UNITED STATES AND CANADA

Intel Corporation
2200 Mission College Boulevard
P.O. Box 58119
Santa Clara, CA 95052-8119
USA
Tel: 408-765-8080

EUROPE

Intel Corporation (U.K.) Ltd.
Pipers Way
Swindon
Wiltshire SN3 1RJ
UK
Tel: +44 (0) 1793 403000

ASIA PACIFIC

Intel Semiconductor Ltd.
32/F Two Pacific Place
88 Queensway, Central
Hong Kong
Tel: (852) 844-4555

JAPAN

Intel Japan K.K.
5-6 Tokodai, Tsukuba-shi
Ibaraki, 300-26
Japan
Tel: +81-298-47-8511

SOUTH AMERICA

Intel Semicondutores do Brazil LTDA
Rua Florida 1703-2 and CJ 22
04565-001-Sao Paulo, SP
Brazil
Tel: 55-11-5505-2296

FOR MORE INFORMATION

To learn more about Intel Corporation
visit our site on the World Wide Web
at <http://www.intel.com/>



* Other brands and names are the property of their respective owners.

Printed in USA/0498/PSA