



General description

BBSC Capacitor targets Optical communication system such as ROSA/TOSA, SONET and all optoelectronics as well as High speed data system or products.

The BBSC is suitable for DC blocking, feedback, coupling and bypassing applications in all broadband optoelectronics and High-speed data system.

The unique technology of integrated passive device in silicon, developed by Murata Integrated Passive Solutions, offers unique performances with low insertion loss, low reflection and phase stability from 160 KHz to 40 GHz.

These capacitors in ultra-deep trenches in silicon have been developed in a semiconductor process, in order to integrate trench MOS capacitor providing high capacitance value of 10 nF (for kHz–MHz range) and high frequency MIM capacitors for low capacitance value for GHz range), both in a SMT 0201 [0.8 x 0.6mm]. The BBSC capacitor provides very high stability of the capacitance over temperature, voltage variation as well as a very high reliability.

BBSC capacitors have an extended operating temperature ranging from -55 to 150°C, with very low capacitance change over temperature (+70ppm/K).

Assembly: Flip chip or embedded applications through existing laminated packages (LGA, BGA) or rigid PCB, FR4 or flex platforms.

Bump finishing: ENIG

Copper pads optional for embedding version and SAC305 type 6 for pre-bumping version, as an optional finishing.

Key features

- Broadband performance to 40 GHz
- Resonance free
- Phase stability
- Insertion loss < 0.4dB Typ. up to 40 GHz
- Ultra-high stability of capacitance value:
 - Temperature 70ppm/K (-55 °C to +150 °C)
 - Voltage <-0.1%/Volt
 - Negligible capacitance loss through ageing
- Low profile: 400µm, 100 µm on request
- Break down voltage : 30V
- Low leakage current < 70pA
- High reliability
- High operating temperature (up to 150 °C)
- Compatible with high temperature cycling during manufacturing operations (exceeding 300 °C)
- Compatible with EIA 0201 footprint

Key applications

- ROSA/TOSA
- SONET
- High speed digital logic
- Microwave/millimetre system
- High volumetric efficiency (i.e. capacitance per unit volume)
- Broadband test equipment

Functional diagram

The next figure provides implementation set-up diagram.



Figure 1 Block Diagram

Electrical performances

Symbol	Parameter	Conditions	Min.	Typ.	Max.	Unit
C	Capacitance value	@+25°C	-	10	-	nF
ΔC_P	Capacitance tolerance ⁽¹⁾	@+25°C	-15	-	+15	%
T _{OP}	Operating temperature		-55	20	150	°C
T _{STG}	Storage temperature ⁽²⁾		-70	-	165	°C
ΔC_T	Capacitance temperature variation	-55 °C to 150 °C	-	70	-	ppm/K
RV _{DC}	Rated voltage ⁽³⁾		-	-	16 ⁽⁴⁾ 14.7 ⁽⁵⁾	V _{DC}
BV	Break down voltage	@+25°C	30	-	-	V
ΔC_{RVDC}	Capacitance voltage variation	From 0 V to RV _{DC} , @+25°C	-	-	-0.1	%/V _{DC}
IR	Insulation resistor	@RV _{DC} , +25°C, 120s	-	10	-	GΩ
F _{c-3dB}	Cut-off frequency at 3dB	@+25°C	-	160	187	kHz
IL	Insertion loss	@ 20 GHz, +25°C	-	0.3	-	dB
		@ 40 GHz, +25°C	-	0.4	-	dB
RL	Return loss	Up to 40 GHz, +25°C	16	-	-	dB
ESD	HBM stress ⁽⁶⁾	JS-001-2017	8	-	-	kV

Table 1 - Electrical performances

⁽¹⁾: other tolerance available upon request

⁽²⁾: without packaging

⁽³⁾: Lifetime is voltage and temperature dependent, please refer to application note 'Lifetime of 3D capacitors'

⁽⁴⁾: 10 years of intrinsic life time prediction at 100°C continuous operation

⁽⁵⁾: 10 years of intrinsic life time prediction at 150°C continuous operation

⁽⁶⁾: please refer to application note 'ESD Challenge in 3D Murata Integrated Passive technology'



Module of S-parameters of 10nF BBSC in transmission mode

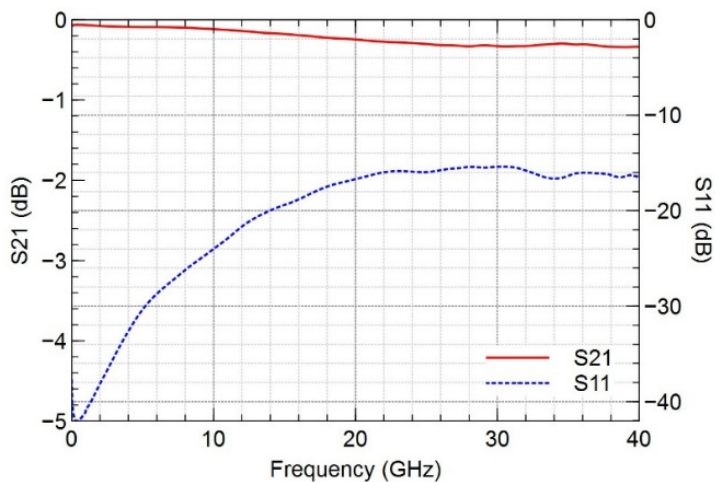
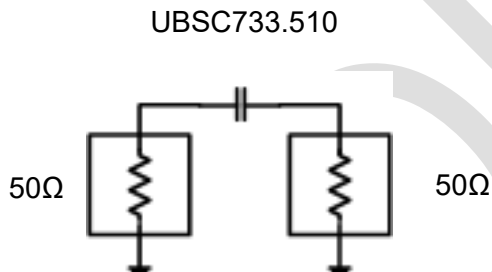

Figure 2 - 10nF BBSC Measured results (module of S-parameters)

Schematic of 10nF BBSC in transmission mode



6.6-mils Rogers 4350B.
Microstrip mode – line width = 0.40 mm and gap = 0.300 mm.
(nominal 50 ohm characteristic impedance).

Figure 3 - 10nF UBSC measurement schematic

Example of 0201 surface mounted

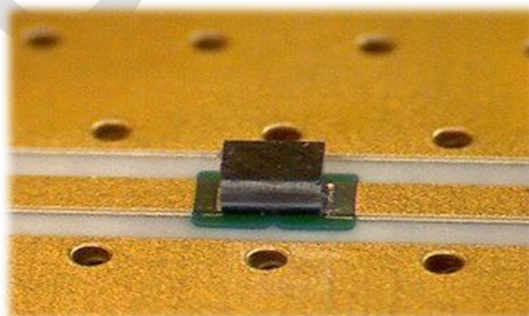

Figure 4 – micro picture of UBSC mounted on board in coplanar mode



FREE S-Parameters-Based Linear Simulation Models for ADS
<http://www.modelithics.com/mvpmurata.asp>



Pinning definition

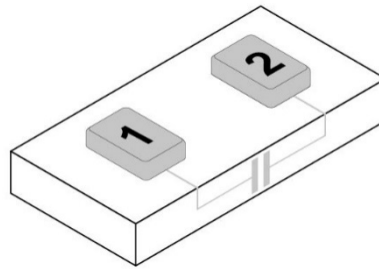

Figure 5 Pinning definition

pin #	Symbol	Coordinates X / Y
1	Signal	-225.0 / 0.0
2	Signal	225.0 / 0.0

Table 2 - Pinning description. Reference (0,0) located at the centre of the die.

Ordering Information

Murata Integrated Passive Devices delivers products with AQL level II (0.65). Tighter quality levels are available upon request.

Part number	Package		
	Packaging	Finishing	Description
939113733510-F1N	6" film frame carrier ⁽¹⁾	ENIG ⁽²⁾	BBSC 0201 - 10nF – 2 pads – 0.8 x 0.6 mm x 0.40mm
939113733510-T3N	T&R 1 000units ⁽³⁾	ENIG ⁽²⁾	BBSC 0201 - 10nF – 2 pads – 0.8 x 0.6 mm x 0.40mm
939113733510-T4N	T&R 10 000units ⁽³⁾	ENIG ⁽²⁾	BBSC 0201 - 10nF – 2 pads – 0.8 x 0.6 mm x 0.40mm
939114733510-F1N	6" film frame carrier ⁽¹⁾	ENIG ⁽²⁾	BBSC 0201 - 10nF – 2 pads – 0.8 x 0.6 mm x 0.10mm
939114733510-T3N	T&R 1 000units ⁽³⁾	ENIG ⁽²⁾	BBSC 0201 - 10nF – 2 pads – 0.8 x 0.6 mm x 0.10mm
939114733510-T4N	T&R 10 000units ⁽³⁾	ENIG ⁽²⁾	BBSC 0201 - 10nF – 2 pads – 0.8 x 0.6 mm x 0.10mm

Table 3 - Packaging and ordering information

- (1) Other film frame carrier are possible on request
- (2) ENIG : Min 0.1µm Au / 5µm Ni
- (3) missing capacitors can reach 0.5%

Product Name	Die Name	Description
BBSC733510	UJ0201510	BBSC 10nF/0201/BV30 – 2 pads – 0.8 x 0.6 x 0.40 mm
BBSC733510	UJ0201510	BBSC 10nF/0201/BV30 – 2 pads – 0.8 x 0.6 x 0.10 mm

Table 4 - Die information



Pad Metallization

This surface mounted Silicon Capacitor is delivered as standard with NiAu (ENIG_(0.1μm Au / 5μm Ni)) finishing. Other Metallization, such as SAC305 type 6 bumping, Copper, Thick Gold or Aluminum pads are possible on request.

Silicon dies are not sensitive to humidity, please refer to applications notes ‘Assembly Notes’ section ‘Handling precautions and storage’.

Material regulation

This product is RoHS compliant at the time of publication. For further information about regulation compliancy, please ask your sales representative.

Package outline

The product is delivered as a bare silicon die

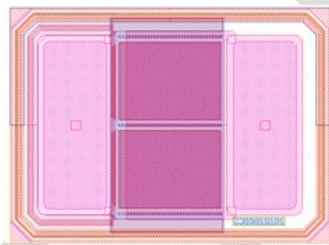

Figure 6 – Layout view

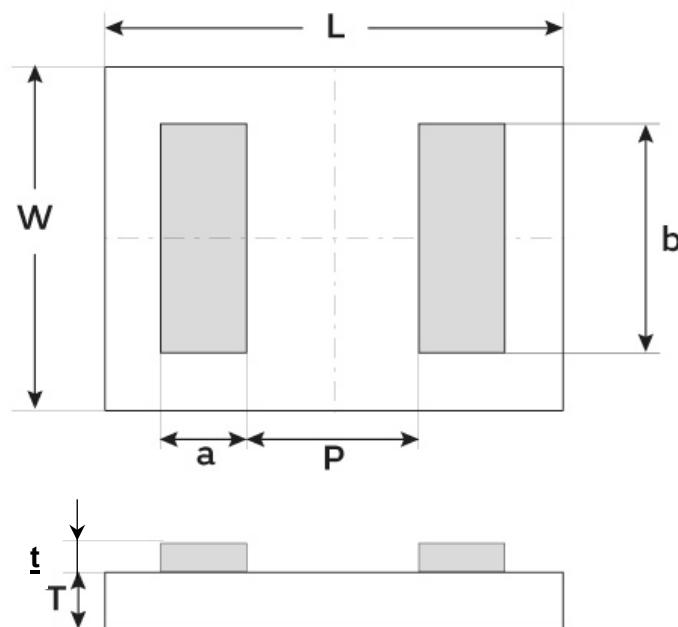

Figure 7: Package outline drawing

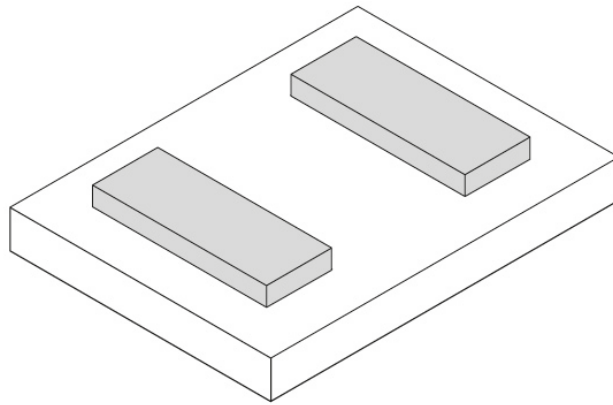

Figure 5 - Package isometric view

L (mm)	W (mm)	T (mm)	a (mm)	P (mm)	b (mm)	t (mm)
0.80 ±0.04	0.60 ±0.04	0.40 or 0.10 ±0.01	0.15	0.30	0.40	0.005 ⁽¹⁾ or 0.04 ⁽²⁾

Table 5 - Dimensions and tolerances

- (1) Standard with ENIG
- (2) Solder joint height after reflow on board in case of SAC305 pre-bumping.



Assembly

The attachment techniques recommended by Murata on the customer’s substrates are fully detailed in specific documents available on our website. To assure the correct use and proper functioning of Murata capacitors **please download the assembly instructions on <https://www.murata.com/en-us/products/capacitor/siliconcapacitors> and read them carefully.**



Figure 6 Scan this QR Code to access the Murata Silicon Capacitor web page

Packaging format

Please refer to application note ‘Products Storage Conditions and Shelf Life’.

Tape and Reel:

Dies are flipped in the tape cavity (bump down) with die ID located near the driving holes of the tape.

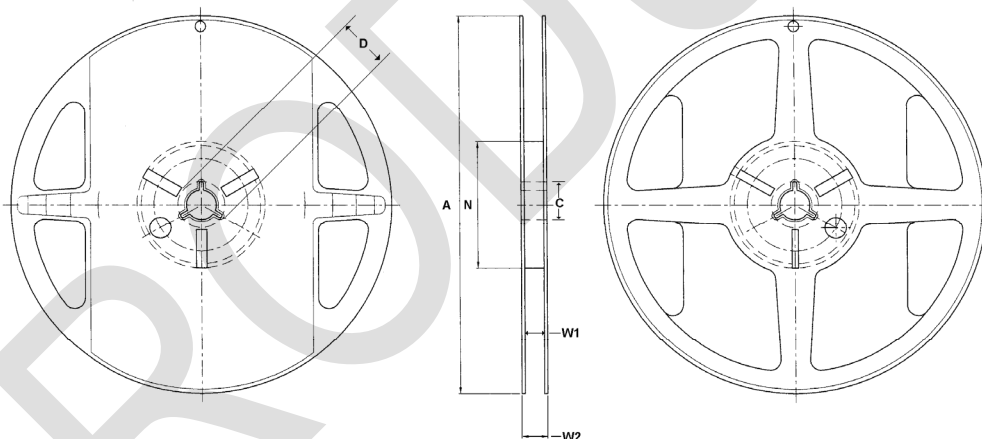

Figure 7 - Reel drawing

Tape Width	Diameter A	C	D	Hub N	W1	W2
8	178 (7 inches)	13.5	20.2	60	9.3	11.5

Table 6 – Reel dimensions (mm)

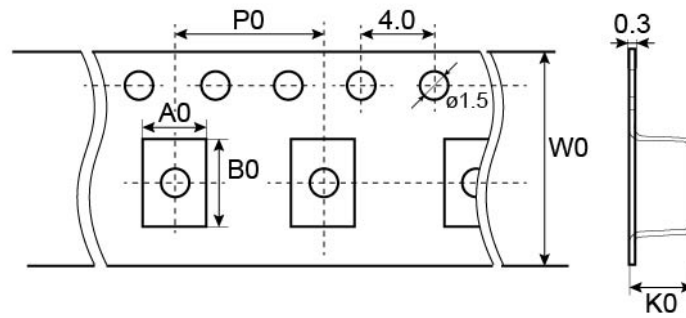

Figure 8 - Tape drawing

Cavity dimensions			Carrier tape width W0	Carrier tape pitch P0	Reel Capacity
Ao	Bo	Ko			
0.65	1.14	0.56	8	2	1 000

Table 7 - Tape dimensions (mm)



Film frame carrier

With UV curable dicing tape (UV performed).

Good dies are identified using the SINF electronic mapping format. No ink is added on wafer to label other dies.

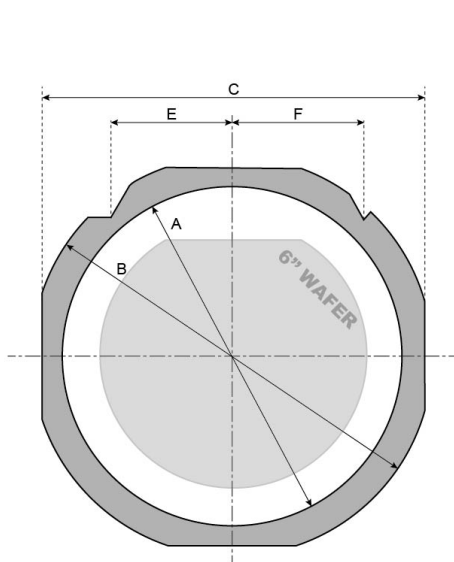

Figure 9 FF070 Frame with a 6" wafer

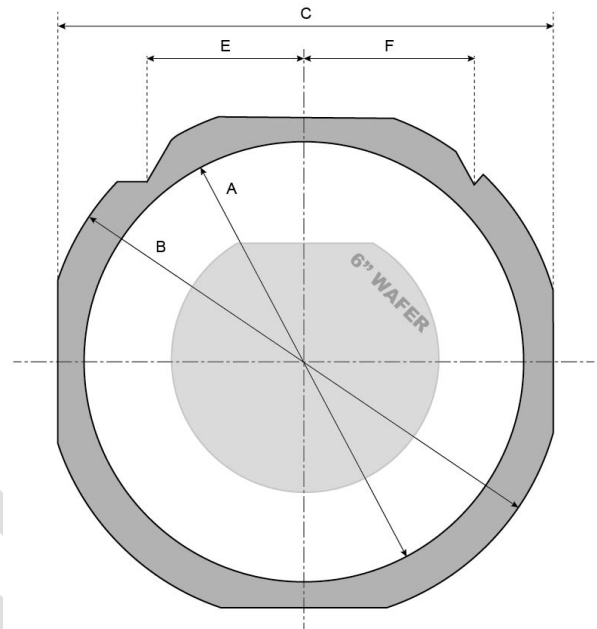

Figure 10 FF108 Frame with a 6" wafer

Frame Reference	Frame Style	Inside diameter A	Outside diameter B	Width C	Thickness	Pin location E	Pin location F
FF070 (1)	DTF-2-6-1	7.638"	8.976"	8.346"	0.048"	2.370"	2.5"
FF108 (1)	DTF-2-8-1	9.842"	11.653"	10.866"	0.048"	2.381"	2.5"

Table 8 - Frame dimensions (inches)

(1) or equivalent



Definitions

Data sheet status

Objective specification: This data sheet contains target or goal specifications for product development.

Preliminary specification: This data sheet contains preliminary data; supplementary data may be published later.

Product specification: This data sheet contains final product specifications.

Limiting values

Stress above one or more of the limiting values may cause permanent damage to the device. These are stress ratings only and operation of the device at these or any other conditions above those given in the Electrical performances sections of this specification is not implied. Exposure to limiting values for extended periods may affect device reliability.

Application information

Where application information is given, it is advisory and does not form part of the specification.

Revision history

Revision	Date	Description	Author
Release 1.0	2016 February 18th	Objective specification	OGA
Release 1.8	2018 April 23th	Transfer FBC 0001	MSI / OGA
Release 3.0	2021 May 07th	Content and layout update	OGA / DDE / LLE/ SCA / CGU

Disclaimer / Life support applications

These products are not designed for use in life support appliances, devices, or systems where malfunction of these products can reasonably be expected to result in personal injury. Murata customers using or selling these products for use in such applications do so at their own risk and agree to fully indemnify Murata for any damages resulting from such improper use or sale.

Reproduction in whole or in part is prohibited without the prior written consent of the copyright owner. The information presented in this document does not form part of any quotation or contract, is believed to be accurate and reliable and may be changed without notice. No liability will be accepted by the publisher for any consequence of its use. Publication thereof does not convey nor imply any license under patent or other industrial or intellectual property rights.

Murata Integrated Passive Solutions S.A. makes no representation that the use of its products in the circuits described herein, or the use of other technical information contained herein, will not infringe upon existing or future patent rights. The descriptions contained herein do not imply the granting of licenses to make, use, or sell equipment constructed in accordance therewith. Specifications are subject to change without notice.



www.murata.com

mis@murata.com