

**PLEASE CHECK WWW.MOLEX.COM FOR LATEST PART INFORMATION**

**Part Number:** [0191890004](#)  
**Status:** **Active**  
**Description:** Krimptite™ Butt Splice for 18-22 AWG Wire

**Documents:**

[Drawing \(PDF\)](#) [RoHS Certificate of Compliance \(PDF\)](#)

**Agency Certification**

CSA LR18689  
 UL E32244

**General**

Product Family Splices  
 Series [19189](#)  
 Crimp Quality Equipment Yes  
 Mil-Spec N/A  
 Product Name Butt, Krimptite™

**Physical**

Barrel Type Closed  
 Insulation None  
 Material - Metal Copper  
 Packaging Type Adhesive Tape on Reel  
 Wire Size AWG 18, 20, 22

**Material Info**

Old Part Number A-145T

**Reference - Drawing Numbers**

Sales Drawing SD-19189-008

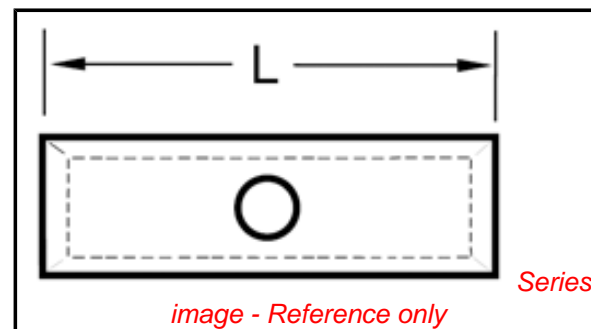

**EU RoHS**

**ELV and RoHS  
 Compliant**

**REACH SVHC**

**Contains SVHC: No**

**Halogen-Free**

**Status**

**Halogen-Free**

**China RoHS**



**Need more information on product  
 environmental compliance?**

Email [productcompliance@molex.com](mailto:productcompliance@molex.com)  
 For a multiple part number RoHS Certificate of  
 Compliance, [click here](#)

Please visit the [Contact Us](#) section for any  
 non-product compliance questions.

**Search Parts in this Series**

[19189Series](#)

**Application Tooling | [FAQ](#)**

*Tooling specifications and manuals are  
 found by selecting the products below.  
 Crimp Height Specifications are then  
 contained in the Application Tooling  
 Specification document.*

**Global**

Description	Product #
ATP Perishable Tool Kit used in ATP presses that process product on tape	<a href="#">0190270026</a>
Mini-Mac™ Applicator	<a href="#">0638854500</a>

MATERIAL NO.	ENG. NO.	WIRE AWG MARKING	DESCRIPTION	DIM. "A"	DIM. "B" OD	DIM. "C" ID	DIM. "D"
191890002	A-145	22-18	LOOSE PIECE	.580 (14.70)	.131 (3.33)	.055 (1.40)	-----
191890008	B-131	16-14	LOOSE PIECE	.580 (14.70)	.163 (4.14)	.078 (1.98)	-----
191890015	C-146	12-10	LOOSE PIECE	.585 (14.90)	.225 (5.71)	.124 (3.15)	-----
191890004	A-145T	22-18	TAPE MOUNTED	.580 (14.70)	.131 (3.33)	.055 (1.40)	.610 (15.49)
191890010	B-131T	16-14	TAPE MOUNTED	.580 (14.70)	.163 (4.14)	.078 (1.98)	.655 (16.64)
191890017	C-146T	12-10	TAPE MOUNTED	.585 (14.90)	.225 (5.71)	.124 (3.15)	.655 (16.64)

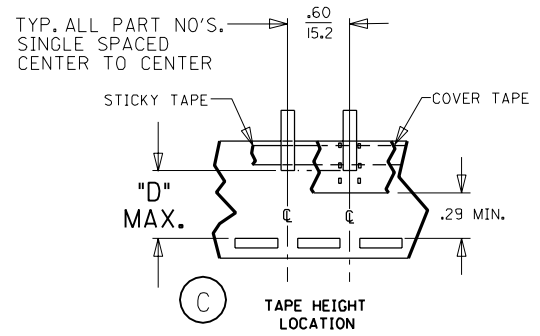

(C)

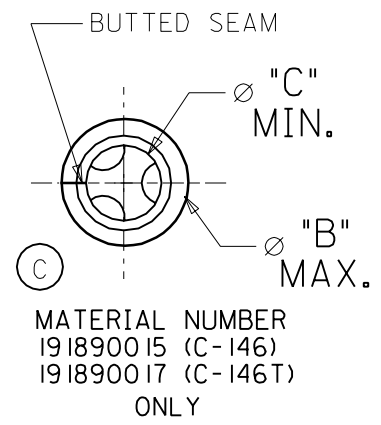
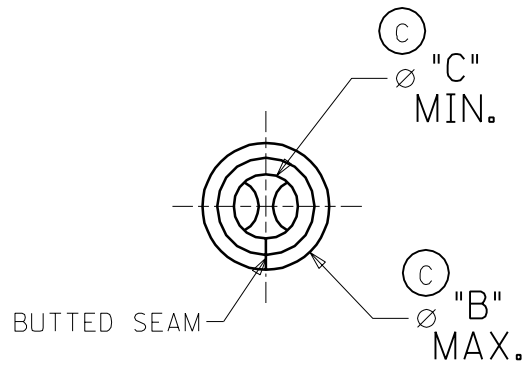
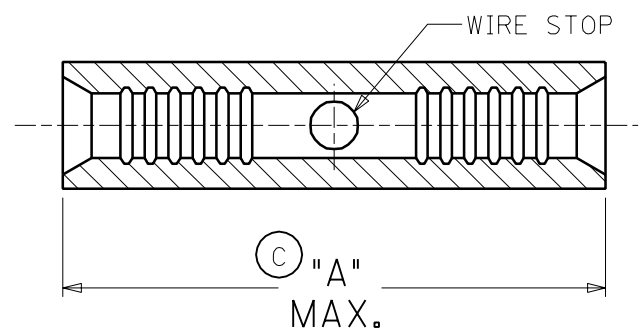

NOTE(S):  
 1. MATERIAL: COPPER  
 2. PLATING: ELECTRO-TIN

WIRE SIZE: 22-18 AWG.  
 0.25-1.3 MM<sup>2</sup>  
 WIRE SIZE: 16-14 AWG.  
 1.0-2.6 MM<sup>2</sup>  
 WIRE SIZE: 12-10 AWG.  
 4.0-6.0 MM<sup>2</sup>

(C) WIRE AWG MARKING LOCATION

# SALES DRAWING

DIM. CHANGES & UPDATES EC NO. ETC2003-0167 DRWN: DLM 03/01/24 CHK: SB 03/01/24 APPR: RWD 03/01/24	DESCRIPTION MAJOR $\blacktriangledown = \emptyset$ CRITICAL $\blacktriangledown^c = \emptyset$	GENERAL TOLERANCES: (UNLESS SPECIFIED)		SCALE 5:1	DESIGN UNITS <input type="checkbox"/> mm <input checked="" type="checkbox"/> INCH	THIRD ANGLE PROJECTION <input checked="" type="checkbox"/> <input type="checkbox"/>	DIMENSIONS: <input type="checkbox"/> mm <input checked="" type="checkbox"/> INCH <input type="checkbox"/> mm ONLY	SHT	REV	
		4 PLACES	$\pm 0.----$	$\pm .----$	DRAWN BY & DATE DLM 03/01/24		TITLE: BUTT CONNECTOR			
		3 PLACES	$\pm 0.---$	$\pm .----$	CHECKED BY & DATE SB 03/01/24		KRIMPTITE			
		2 PLACES	$\pm 0.---$	$\pm .----$	APPROVED BY & DATE RWD 03/01/24		22-18, 16-14, & 12-10 AWG			
1 PLACE	$\pm 0.---$	$\pm .---$	ANGULAR: $\pm \text{ }^\circ$		CAD FILENAME SD19189008.DGN		MATERIAL NO. (SEE CHART)	DRAWING NO. SD-19189-008	SHEET NO. 1 OF 1	
REV		DRAFT WHERE APPLICABLE MUST REMAIN WITHIN DIMENSIONS		THIS DRAWING CONTAINS INFORMATION THAT IS PROPRIETARY TO MOLEX INCORPORATED AND SHOULD NOT BE USED WITHOUT WRITTEN PERMISSION.						