



Preliminary and Provisional

## 2-CHANNEL STEP-UP PWM CONTROLLERS

### Features

- Complete PWM Power Control Circuitry
- Under-voltage Lockout Protection
- Totem pole Output
- Output Short Circuit Protection
- Dead Time Control : 0 to 100%
- Wide Operating Frequency :  
10kHz to 800kHz
- Shut Down Control
- Power Good Protection

### Pin Configuration

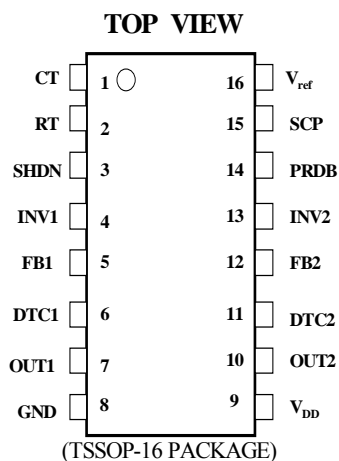

### General Description

The AAT1106 series provides an integrated two-channel pulse-width-modulation (PWM) solution for the power supply of DC-DC system, this device offers the systems engineer the flexibility to tailor the power supply circuitry to a specific application. Each channel contains its own error amplifier, PWM comparator, dead-time control and output driver. The under-voltage protection, oscillator, short circuit protection and voltage reference circuit are common for the two channels.

The AAT1106 contains two boost (step-up) exclusive circuit. Dead-time control (DTC) can be set to provide 0% to 100% dead time by resistive divider network. Soft start can be implemented by paralleling the DTC resistor with a capacitor. Two dead time control inputs are assigned for Ch-1 and Ch-2 individually, and dead time control inputs can be used to control on / off operation.

With a minimum number of external components, the AAT1106 series offers a simple and cost effective solution.

\*Spec is subject to change without notice in this document.

**Pin Description**

Pin #	Name	I/O	Description
1	CT	I	External timing capacitance
2	RT	I	External timing resistance
3	SHDN	I	Shut down input pin ( internal pull "H" )
4	INV1	I	Negative input for error amplifier 1
5	FB1	I	Output for error amplifier 1
6	DTC1	I	Output 1 dead time / soft start setting
7	OUT1	O	Output 1
8	GND		Ground
9	V <sub>DD</sub>	I	Power supply
10	OUT2	O	Output 2
11	DTC2	I	Output 2 dead time / soft start setting
12	FB2	I	Output for error amplifier 2
13	INV2	I	Negative input for error amplifier 2
14	PRDB	I	Power good output pin
15	SCP	I	Timer latch setting
16	V <sub>ref</sub>	O	Reference voltage (2.505V) output

**Absolute Maximum Ratings**

CHARACTERISTICS	SYMBOL	VALUE	UNIT
Supply voltage	$V_{DD}$	7	V
Input voltage (IN-, DTC, SHDN)	$V_I$	$V_{DD}$	V
Output voltage	$V_O$	$V_{DD}+0.3$	V
Output current	$I_O$	-120/+120	mA
Operating free-air temperature range	$T_{ope}$	-20 to 85	°C
Storage temperature range	$T_{stg}$	-65 to 150	°C
Power dissipation	$P_d$	500	mW

**Recommended Operating Conditions**

	Symbol	Min	Max	Unit
Supply voltage, $V_{DD}$	$V_{DD}$	4.0	6.5	V
Input voltage, INV1, INV2	$V_{cm}$	0.5	1.6	V
Output voltage	$V_O$	0	$V_{DD}$	V
OSC capacitor	$C_T$	100	15000	pF
OSC resistor (Note 1)	$R_T$	5.1	50	k $\Omega$
Oscillator frequency	$f_{OSC}$	10	800	kHz
Output current, Iout1, Iout2	$I_O$		+50/-50	mA
Operating free-air temperature	$T_{ope}$	-20	85	°C

**Electrical Characteristics,  $V_{DD} = 5.0V$  (Unless Otherwise Specified) (See Note 1)****Oscillator**

Parameter		Test Condition	Min	Typ	Max	Unit
Frequency	$f_{OSC}$	$C_T = 220pF, R_T = 10k\Omega$	320	400	480	KHz
Frequency change with $V_{DD}$	$f_{dv}$	$V_{DD} = 4.0V$ to $6.0V$ , $T_A = 25^\circ C$ $C_T = 220pF, R_T = 10k\Omega$		1		%

**Under-voltage Protection**

Parameter		Test Condition	Min	Typ	Max	Unit
Upper threshold voltage	$V_{UPH}$	$T_A = 25^\circ C$	2.6	2.9	3.2	V
Lower threshold voltage	$V_{UPL}$	$T_A = 25^\circ C$	2.23	2.53	2.83	V
Hysteresis ( $V_{UPH} - V_{UPL}$ )	$V_{HYS}$	$T_A = 25^\circ C$		0.37		V

**Short Circuit Protection Control**

Parameter		Test Condition	Min	Typ	Max	Unit
Input threshold voltage	$V_{r1}$	Ch-1, 2	2.1	2.4	2.65	V
Short-circuit detect threshold voltage	$V_{r2}$		1.48	1.64	1.8	V
SCP terminal source current	$I_{SCP}$		-1.5	-2.5	-3.5	$\mu A$
Standby Voltage	$V_{STB}$			50	100	mV
Latch Voltage	$V_{LT}$			30	100	mV

**Shun Down Control ( Internal pull "H" )**

Parameter		Test Condition	Min	Typ	Max	Unit
Shut down enable voltage	$V_{sdL}$	$T_A = 25^\circ C$			0.5	V
Shut down release voltage	$V_{sdH}$	$T_A = 25^\circ C$	2.0			V

Note1 : Typical values of all parameters are specified at  $T_A = 25^\circ C$ .



**Electrical Characteristics,  $V_{DD} = 5.0V$  (Unless Otherwise Specified) (See Note 1) (continued)**  
**Reference Voltage**

Parameter		Test Conditions	Min	Typ	Max	Unit
Internal reference Voltage	$V_{refi}$	$I_{REF} = -1mA, T_A = 25^\circ C$	1.220	1.233	1.246	V
Reference voltage	$V_{REF}$	$I_{REF} = -1mA, T_A = 25^\circ C$	2.430	2.505	2.580	
Input voltage regulation	$V_{RI}$	$I_{REF} = -1mA,$ $V_{DD} = 4.0V$ to $6.0V$		1	5	mV
Output regulation	$V_{RO}$	$I_{REF} = -0.1mA$ to $-1mA$		1		mV

**EA (Error Amplifier)**

Parameter		Test Condition	Min	Typ	Max	Unit
Input offset voltage	$V_{IO}$	Ch-1,2, $A_v=1$			6	mV
Input bias current	$I_{IB}$	Ch-1,2		$\pm 15$	$\pm 100$	nA
Input voltage range	$V_{IR}$	Ch-1,2	0.5		1.6	V
Open-loop voltage amplification	$A_{VD}$		70	85		dB
Output voltage swing	$V_{OM+}$		2.3	2.5		V
	$V_{OM-}$			0.7	0.9	
Output sink current	$I_{OM+}$	FB=1.25V	3	20		mA
Output source current	$I_{OM-}$	FB=1.25V	-45	-75		$\mu A$
Common-mode rejection ratio	CMRR		60	80		dB

**Electrical Characteristics,  $V_{DD} = 5.0V$  (Unless Otherwise Specified) (See Note 1) (continued)****Dead Time Control & PWM**

Parameter		Test Condition	Min	Typ	Max	Unit
Input bias current	$I_{BDT}$	$V_{DTC} = 2V$		0.1	1	$\mu A$
Input threshold voltage (DTC)	$V_{d0}$	Duty = 0%, $f_{OSC} = 10kHz$	1.38	1.48	1.58	V
	$V_{d100}$	Duty = 100%, $f_{OSC} = 10kHz$	1.87	1.97	2.07	
Latch input voltage	$V_{DT}$	$I_{DT} = 100\mu A$		0.1	0.3	V
Latch mode source current	$I_{DT}$	DTC1,2=2.0V	200	500		$\mu A$

**Output Stage**

Parameter		Test Condition	Min	Typ	Max	Unit
High-level output voltage	$V_{OH}$	$I_O = -50mA$	3.6	4.0		V
Low-level output voltage	$V_{OL}$	$I_O = +50mA$		0.8	1.2	V
Rise time	$T_{rise}$	$C_L = 1000pF$		100		nS
Fail time	$T_{fail}$	$C_L = 1000pF$		100		nS
Leakage current	$I_{peak}$	$V_o = 6.0V$			5	$\mu A$

**Operating Current**

Parameter		Test Condition	Min	Typ	Max	Unit
Supply current	$I_{DD-OFF}$	Output "OFF" state		1.8		mA
	$I_{DD-ON}$	$P_{RT} = 10k$		2.0		mA



Function Block Diagram

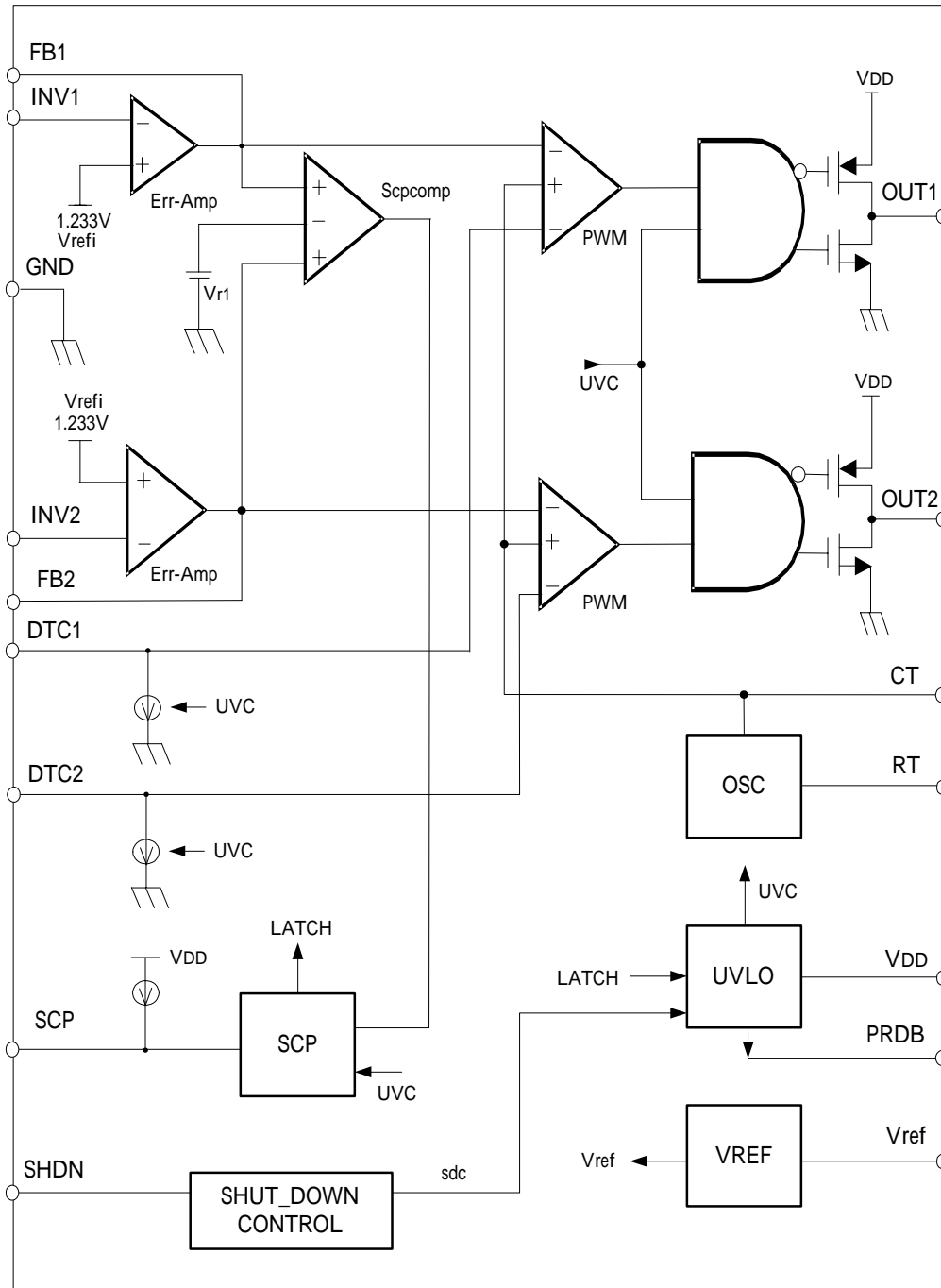



Application Circuit 1

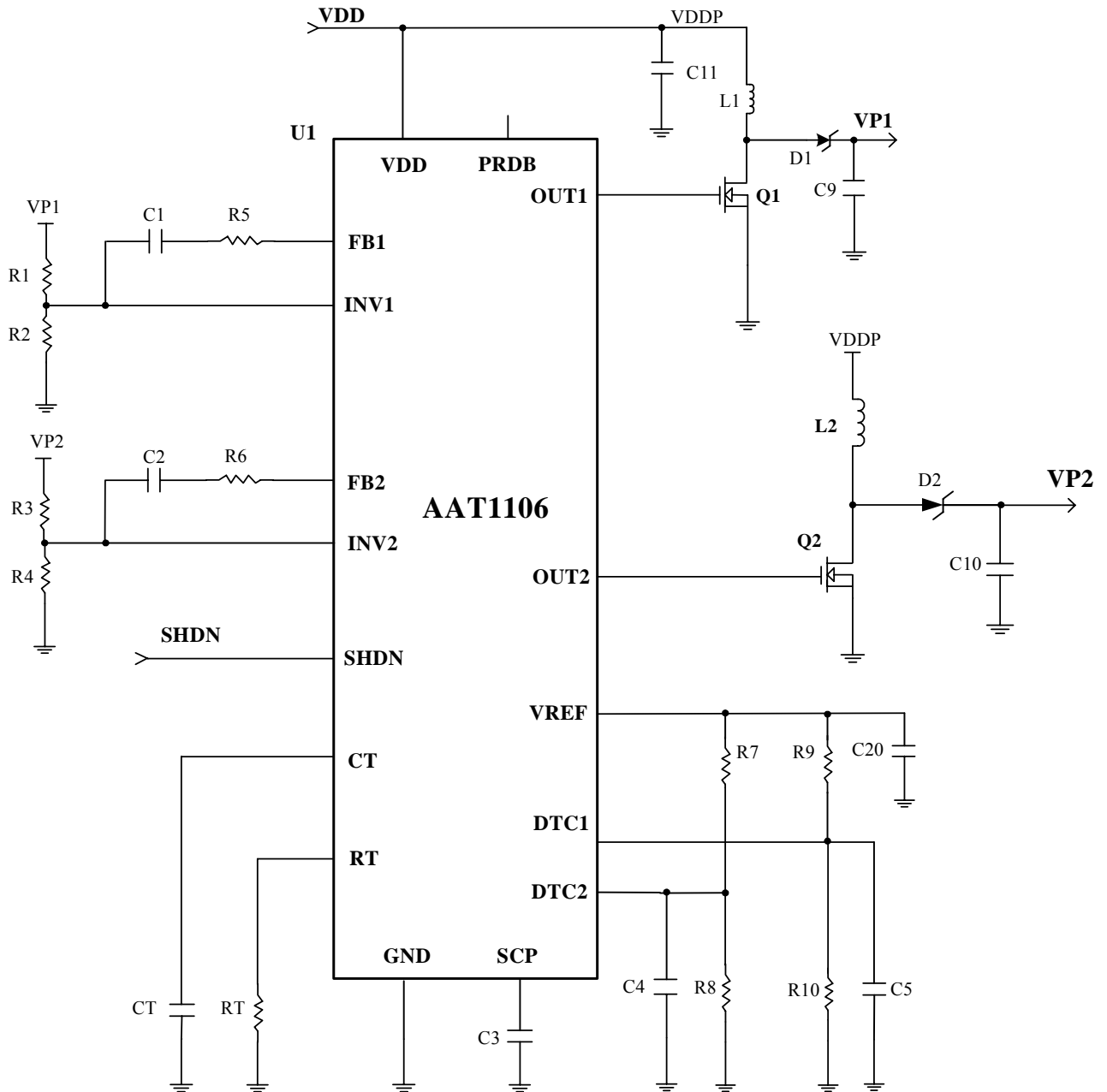





Application Circuit 2

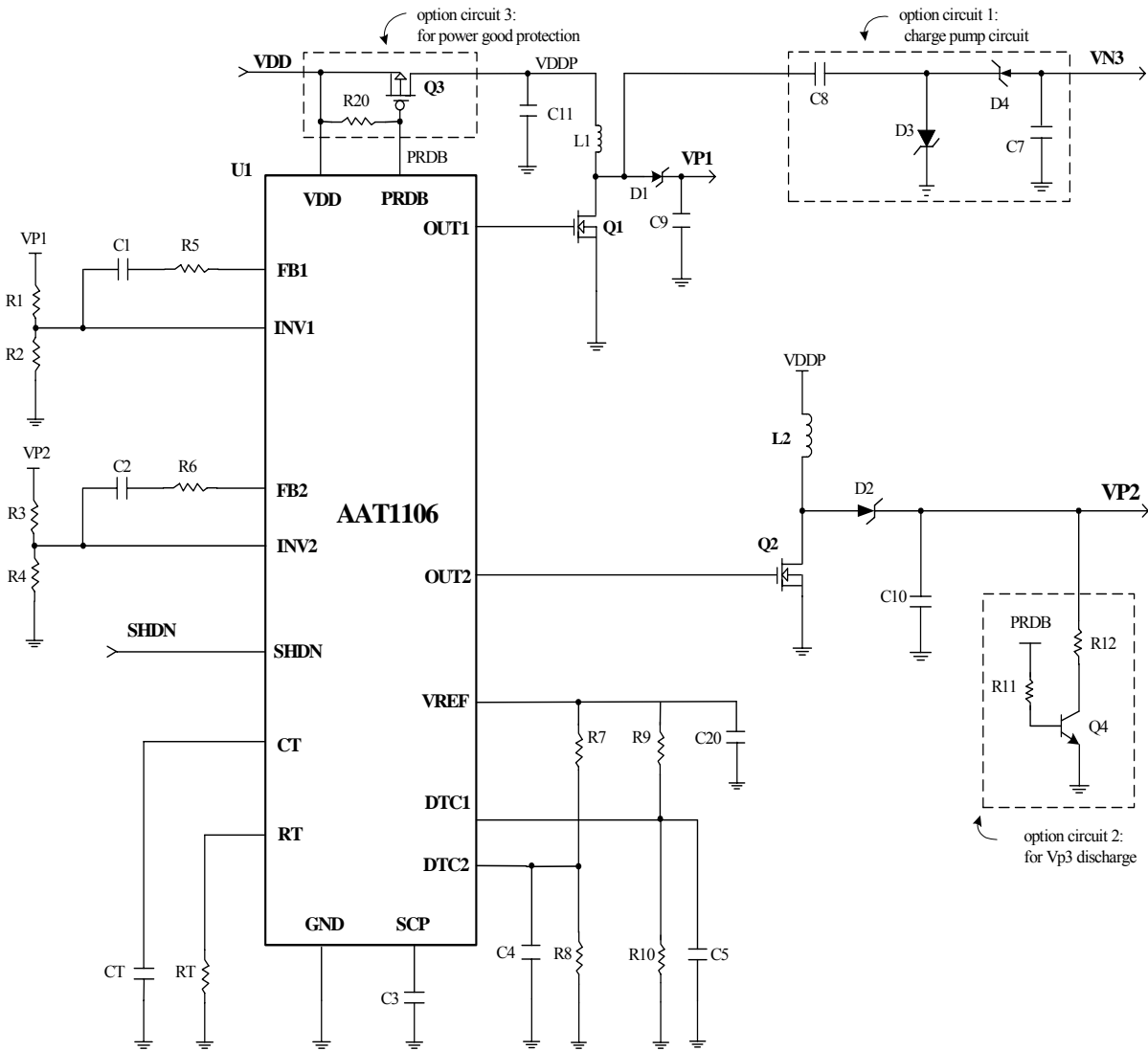



**Boost ( Step-up ) Timing Chart**

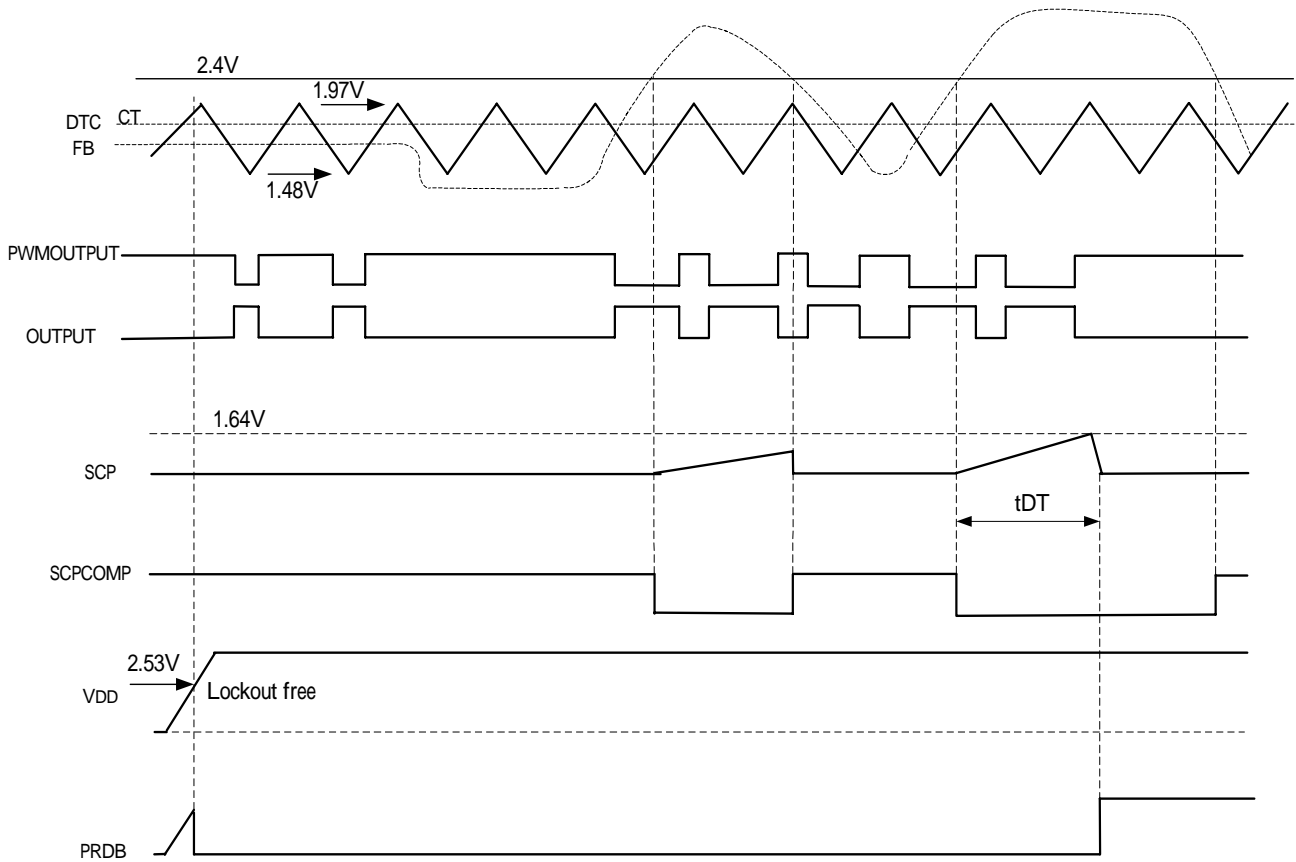



Package Dimension (Unit: Mil)

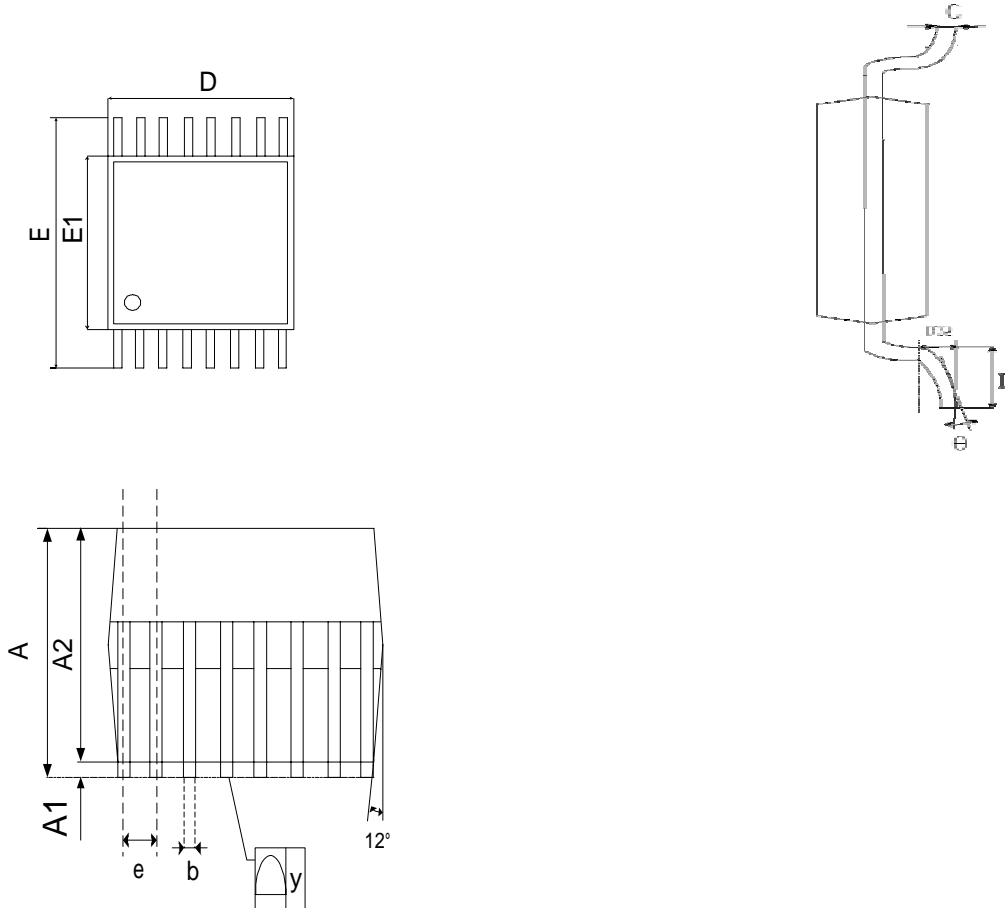

	DIMENSIONS IN MILLIMETERS			DIMENSIONS IN INCHES		
	MIN	NOM	MAX	MIN	NOM	MAX
A	1.05	1.10	1.20	0.041	0.043	0.047
A1	0.05	0.10	0.15	0.002	0.004	0.006
A2	—	1.00	1.05	—	0.039	0.041
b	0.20	0.25	0.28	0.008	0.010	0.011
C	—	0.127	—	—	0.005	—
D	4.90	5.075	5.10	0.193	0.1998	0.200
E	6.20	6.40	6.60	0.244	0.252	0.260
E1	4.30	4.40	4.50	0.170	0.173	0.177
e	—	0.65	—	—	0.026	—
L	0.5	0.60	0.70	0.02	0.024	0.028
y	—	—	0.076	—	—	0.003
	0°	4°	8°	0°	4°	8°