

ACPL-K34T

Automotive 2.5 A Peak High Output Current MOSFET Gate Drive Optocoupler with Rail-to-Rail Output Voltage in Stretched SO8



Data Sheet



Lead (Pb) Free
RoHS 6 fully compliant

RoHS 6 fully compliant options available;
-xxxE denotes a lead-free product

Description

Avago's 2.5 Amp Automotive R²Coupler Gate Drive Optocoupler contains an AlGaAs LED, which is optically coupled to an integrated circuit with a power output stage. The ACPL-K34T features fast propagation delay and tight timing skew, is ideally designed for driving power MOSFETs used in AC-DC and DC-DC converters. The high operating voltage range of the output stage provides the drive voltages required by gate controlled devices. The voltage and high peak output current supplied by this optocoupler make it ideally suited for direct driving power MOSFETs at high frequency for high efficiency conversion.

Avago R²Coupler isolation products provide reinforced insulation and reliability that delivers safe signal isolation critical in automotive and high temperature industrial applications.

Functional Diagram

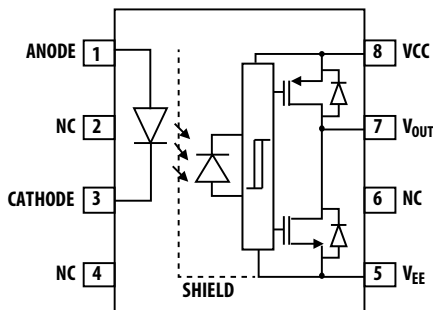

Figure 1. ACPL-K34T Functional Diagram

Note: Minimum 1 μ F bypass capacitor must be connected between pins V_{CC} and V_{EE}.

Truth Table

LED	V _{CC} - V _{EE}	V _{OUT}
OFF	0 - 20V	LOW
ON	<V _{UVLO-}	LOW
ON	>V _{UVLO+}	HIGH

Features

- Qualified to AEC-Q100 Grade 1 Test Guidelines
- Automotive temperature range: -40 °C to 125 °C
- Peak output current: 2.0 A min.
- Rail-to-rail output voltage
- Propagation delay: 110 ns max.
- Dead time distortion: +50 ns/-40 ns
- LED current input drive with hysteresis
- Common Mode Rejection (CMR): 50 kV/ μ s min. at V_{CM} = 1500 V
- Low supply current allow bootstrap half-bridge topology: I_{CC} = 3.9 mA max.
- Under Voltage Lock-Out (UVLO) protection with hysteresis for power MOSFET
- Wide operating V_{CC} range: 10 V to 20 V
- Safety Approvals:
 - UL Recognized 5000 V_{RMS} for 1 min
 - CSA
 - IEC/EN/DIN EN 60747-5-5 V_{IORM} = 1140 V_{peak}

Applications

- Hybrid Power Train DC/DC Converter
- EV/PHEV Charger
- Automotive Isolated MOSFET Gate Drive
- AC and Brushless DC motor drives

CAUTION: It is advised that normal static precautions be taken in handling and assembly of this component to prevent damage and/or degradation which may be induced by ESD.

Ordering Information

Part number	Option (RoHS Compliant)	Package	Surface Mount	Tape & Reel	UL 5000 V _{rms} / 1 Minute rating	IEC/EN/DIN EN 60747-5-5	Quantity
ACPL-K34T	-000E	Stretched	X		X		80 per tube
	-060E	SO-8	X		X	X	80 per tube
	-500E		X	X	X		1000 per reel
	-560E		X	X	X	X	1000 per reel

To order, choose a part number from the part number column and combine with the desired option from the option column to form an order entry.

Example 1:

ACPL-K34T-560E to order product of SSO-8 Surface Mount package in Tape and Reel packaging with IEC/EN/DIN EN 60747-5-5 Safety Approval in RoHS compliant.

Option datasheets are available. Contact your Avago sales representative or authorized distributor for information.

Package Outline Drawings (Stretched SO8)

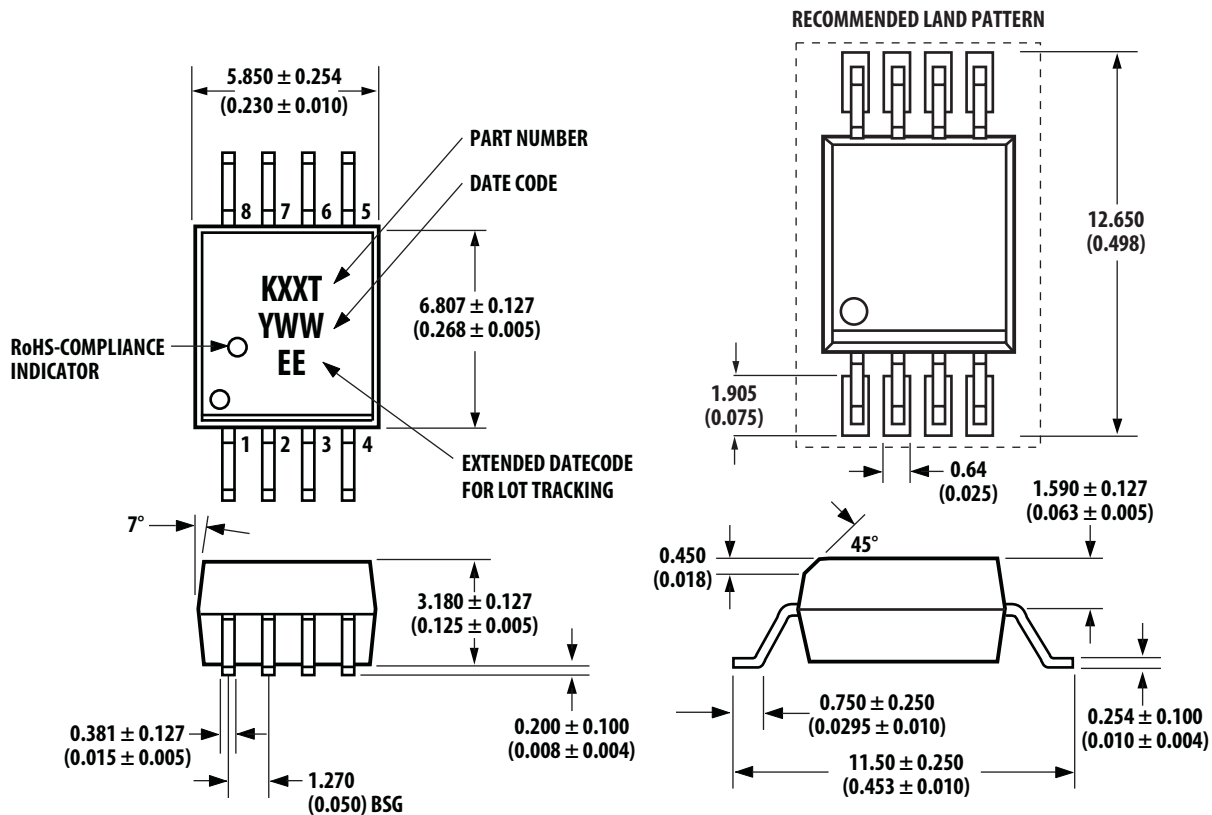

Recommended Pb-Free IR Profile

Recommended reflow condition as per JEDEC Standard, J-STD-020 (latest revision).

Note: Non-halide flux should be used

Regulatory Information

The ACPL-K34T is approved by the following organizations:

UL	UL 1577, component recognition program up to $V_{ISO} = 5 \text{ kV}_{RMS}$
CSA	CSA Component Acceptance Notice #5.
IEC/EN/DIN EN 60747-5-5	IEC 60747-5-5 EN 60747-5-5 DIN EN 60747-5-5

IEC/EN/DIN EN 60747-5-5 Insulation Related Characteristic (Option 060 and 560 only)

Description	Symbol	Option 060 and 560	Units
Installation classification per DIN VDE 0110/1.89, Table 1 for rated mains voltage < 600 V_{rms} for rated mains voltage < 1000 V_{rms}		I – IV I – III	
Climatic Classification		40/125/21	
Pollution Degree (DIN VDE 0110/1.89)		2	
Maximum Working Insulation Voltage	V_{IORM}	1140	V_{peak}
Input to Output Test Voltage, Method b $V_{IORM} \times 1.875 = V_{PR}$, 100% Production Test with $t_m = 1 \text{ sec}$, Partial discharge < 5 pC	V_{PR}	2137	V_{peak}
Input to Output Test Voltage, Method a $V_{IORM} \times 1.6 = V_{PR}$, Type and Sample Test with $t_m = 10 \text{ sec}$, Partial discharge < 5 pC	V_{PR}	1824	V_{peak}
Highest Allowable Overvoltage (Transient Overvoltage $t_{ini} = 60 \text{ sec}$)	V_{IOTM}	8000	V_{peak}
Safety-limiting values – maximum values allowed in the event of a failure, also see Figure 5.			
Case Temperature	T_s	175	$^{\circ}\text{C}$
Input Current	$I_{S, INPUT}$	230	mA
Output Power	$P_{S, OUTPUT}$	600	mW
Insulation Resistance at T_s , $V_{IO} = 500 \text{ V}$	R_s	$> 10^9$	Ω

Insulation and Safety Related Specifications

Parameter	Symbol	ACPL-K34T	Units	Conditions
Minimum External Air Gap (Clearance)	L(101)	8	mm	Measured from input terminals to output terminals, shortest distance through air.
Minimum External Tracking (Creepage)	L(102)	8	mm	Measured from input terminals to output terminals, shortest distance path along body.
Minimum Internal Plastic Gap (Internal Clearance)		0.08	mm	Through insulation distance conductor to conductor, usually the straight line distance thickness between the emitter and detector.
Tracking Resistance (Comparative Tracking Index)	CTI	175	V	DIN IEC 112/VDE 0303 Part 1
Isolation Group (DIN VDE0109)		IIIa		Material Group (DIN VDE 0109)

Absolute Maximum Ratings

Parameter	Symbol	Min.	Max.	Units	Note
Storage Temperature	T_S	-55	150	°C	
Operating Temperature	T_A	-40	125	°C	
IC Junction Temperature	T_J		150	°C	3
Average Input Current	$I_{F(AVG)}$		20	mA	
Peak Input Current (50% duty cycle, < 1 ms pulse width)	$I_{F(PEAK)}$		40	mA	
Peak Transient Input Current (<1 μ s pulse width, 300 pps)	$I_{F(TRAN)}$		1	A	
Reverse Input Voltage	V_R		6	V	
“High” Peak Output Current	$I_{OH(PEAK)}$		2.5	A	1
“Low” Peak Output Current	$I_{OL(PEAK)}$		2.5	A	1
Total Output Supply Voltage	$(V_{CC} - V_{EE})$	0	25	V	
Output Voltage	$V_{O(PEAK)}$	-0.5	V_{CC}	V	
Output IC Power Dissipation	P_O		500	mW	2
Total Power Dissipation	P_T		550	mW	3

Recommended Operating Conditions

Parameter	Symbol	Min	Max.	Units	Note
Operating Temperature	T_A	-40	125	°C	
Output Supply Voltage	$(V_{CC} - V_{EE})$	10	20	V	
Input Current (ON)	$I_{F(ON)}$	7	13	mA	
Input Voltage (OFF)	$V_{F(OFF)}$	-5.5	0.8	V	

Electrical Specifications (DC)

Unless otherwise noted, all Minimum/Maximum specifications are at Recommended Operating Conditions. All typical values are at $T_A = 25\text{ }^\circ\text{C}$, $V_{CC} - V_{EE} = 10\text{ V}$, $V_{EE} = \text{Ground}$.

Parameter	Symbol	Min.	Typ.	Max.	Units	Test Conditions	Fig.	Note
High Level Peak Output Current	I_{OH}		-3.5	-2.0	A	$V_{CC} - V_O = 10\text{ V}$	3	
Low Level Peak Output Current	I_{OL}	2.0	4.4		A	$V_O - V_{EE} = 10\text{ V}$	4	
High Output Transistor RDS(ON)	$R_{DS,OH}$		2.2	4.0	Ω	$I_{OH} = -2.0\text{ A}$		4
Low Output Transistor RDS(ON)	$R_{DS,OL}$		1.0	2.0	Ω	$I_{OL} = 2.0\text{ A}$		4
High Level Output Voltage	V_{OH}	$V_{CC}-0.4$	$V_{CC}-0.2$		V	$I_F = 10\text{ mA}$, $I_O = -100\text{ mA}$		5, 6
Low Level Output Voltage	V_{OL}		0.1	0.25	V	$I_O = 100\text{ mA}$		
High Level Supply Current	I_{CCH}		2.5	3.9	mA	$I_F = 10\text{ mA}$		5
Low Level Supply Current	I_{CCL}		2.5	3.9	mA	$V_F = 0\text{ V}$		6
Threshold Input Current Low to High	I_{FLH}		1.5	4.9	mA	$V_O > 5\text{ V}$		7
Threshold Input Voltage High to Low	V_{FHL}	0.8			V			
Input Forward Voltage	V_F	1.25	1.5	1.85	V	$I_F = 10\text{ mA}$		7
Temperature Coefficient of Input Forward Voltage	$\Delta V_F / \Delta T_A$		-1.5		mV/°C			
Input Reverse Breakdown Voltage	BV_R	6			V	$I_R = 100\text{ }\mu\text{A}$		
Input Capacitance	C_{IN}		90		pF	$f = 1\text{ MHz}$, $V_F = 0\text{ V}$		
UVLO Threshold	V_{UVLO+}	8.1	8.6	9.1	V	$V_O > 5\text{ V}$, $I_F = 10\text{ mA}$		8
	V_{UVLO-}	7.1	7.6	8.1				8
UVLO Hysteresis	$UVLO_{HYS}$	0.5	1.0		V			

Switching Specifications (AC)

Unless otherwise noted, all Minimum/Maximum specifications are at Recommended Operating Conditions. All typical values are at $T_A = 25\text{ }^\circ\text{C}$, $V_{CC} - V_{EE} = 10\text{ V}$, $V_{EE} = \text{Ground}$.

Parameter	Symbol	Min.	Typ.	Max.	Units	Test Conditions	Fig.	Note
Propagation Delay Time to High Output Level	t_{PLH}	30	60	110	ns	$V_{CC} = 10\text{ V}$ $R_G = 4.7\Omega$, $C_L = 10\text{ nF}$	9,12,14	7
Propagation Delay Time to Low Output Level	t_{PHL}	30	60	110	ns	$f = 200\text{ kHz}$, Duty Cycle = 50%	10,12,14	
Pulse Width Distortion ($t_{PHL} - t_{PLH}$)	PWD	-40	0	40	ns	$V_{in} = 4.5\text{ V} - 5.5\text{ V}$, $R_{in} = 350\ \Omega$	11	8
Dead Time Distortion Caused by Any Two Parts ($t_{PLH} - t_{PHL}$)	DTD	-40		50	ns			9
Rise Time	t_R		10	30	ns	$V_{CC} = 10\text{ V}$, $C_L = 1\text{ nF}$, $f = 200\text{ kHz}$, Duty Cycle = 50%	13, 14	
Fall Time	t_F		10	30	ns	$V_{in} = 4.5\text{ V} - 5.5\text{ V}$, $R_{in} = 350\ \Omega$		
Output High Level Common Mode Transient Immunity	$ CM_H $	50	>75		kV/ μs	$T_A = 25\text{ }^\circ\text{C}$, $V_{CC} = 20\text{ V}$, $V_{CM} = 1500\text{ V}$, with split resistors	15	10, 11
Output Low Level Common Mode Transient Immunity	$ CM_L $	50	>75		kV/ μs			10, 12

Package Characteristics

Unless otherwise noted, all Minimum/Maximum specifications are at Recommended Operating Conditions. All typical values are at $T_A = 25\text{ }^\circ\text{C}$.

Parameter	Symbol	Min.	Typ.	Max.	Units	Test Conditions	Fig.	Note
Input-Output Momentary Withstand Voltage*	V_{ISO}	5000			V_{RMS}	$RH < 50\%$, $t = 1\text{ min}$, $T_A = 25\text{ }^\circ\text{C}$		13, 14
Input-Output Resistance	R_{I-O}		10^{14}		Ω	$V_{I-O} = 500\text{ V}_{DC}$		14
Input-Output Capacitance	C_{I-O}		0.6		pF	$f = 1\text{ MHz}$		

* The Input-Output Momentary Withstand Voltage is a dielectric voltage rating that should not be interpreted as an input-output continuous voltage rating. For the continuous voltage rating, refer to your equipment level safety specification or Avago Technologies Application Note 1074 entitled "Optocoupler Input-Output Endurance Voltage."

Notes:

1. Maximum pulse width = 100 ns, Duty cycle = 2%.
2. Derate linearly above 110 °C free-air temperature at a rate of 13 mW/°C. Refer to Figure 2 from Output IC Power Dissipation Derating Chart.
3. Total power dissipation is derated linearly above 110 °C free-air temperature at a rate of 13 mW/°C. The maximum LED and IC junction temperature should not exceed 150 °C.
4. Output is source at -2.0 A or 2.0 A with a maximum pulse width of 10 μ s.
5. In this test V_{OH} is measured with a DC load current. When driving capacitive loads V_{OH} will approach V_{CC} as I_{OH} approaches zero amps.
6. Maximum pulse width = 1 ms.
7. This load condition approximates the gate load of a 600 V/50 A power MOSFET.
8. Pulse Width Distortion (PWD) is defined as $t_{PHL} - t_{PLH}$ for any given device.
9. Dead Time Distortion (DTD) is defined as $t_{PLH} - t_{PHL}$ between any two parts under the same test condition. A negative DTD reduces original system dead time; while a positive DTD increases original system dead time.
10. Pin 2 and Pin 4 must be connected to LED common.
11. Common mode transient immunity in the high state is the maximum tolerable dV_{CM}/dt of the common mode pulse, V_{CM} , to assure that the output will remain in the high state, (i.e., $V_O > 10$ V).
12. Common mode transient immunity in a low state is the maximum tolerable dV_{CM}/dt of the common mode pulse, V_{CM} , to assure that the output will remain in a low state (i.e., $V_O < 1.0$ V).
13. In accordance with UL1577, each optocoupler is proof-tested by applying an insulation test voltage ≥ 6000 V_{RMS} for 1 second.
14. Device considered a two-terminal device: pins 1, 2, 3 and 4 shorted together and pins 5, 6, 7 and 8 shorted together.

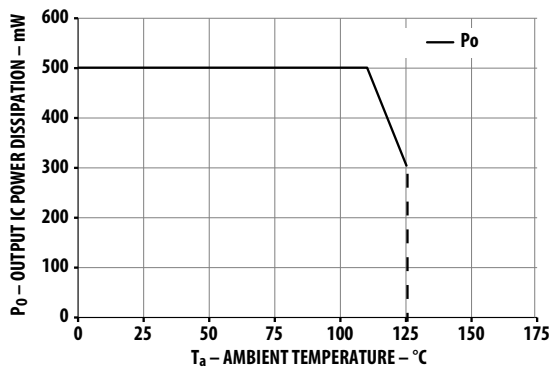

Figure 2. Output IC Power Dissipation Derating Chart

Typical Performance Plots

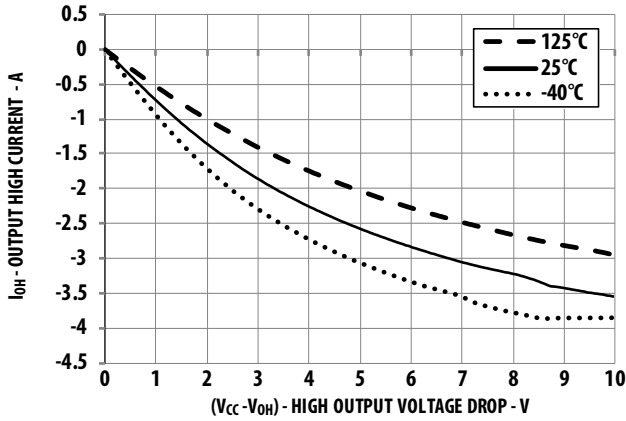

Figure 3. I_{OH} vs. $(V_{CC} - V_{OH})$

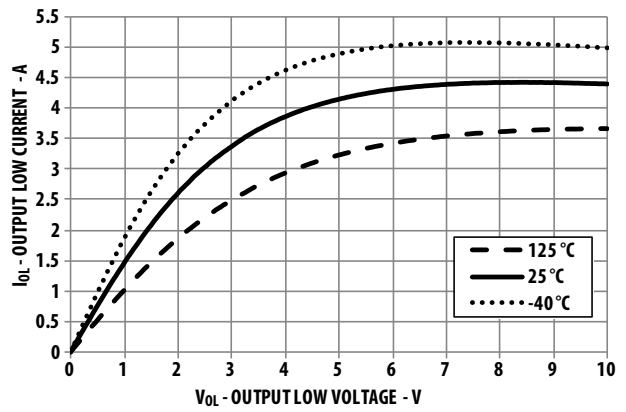

Figure 4. I_{OL} vs. V_{OL}

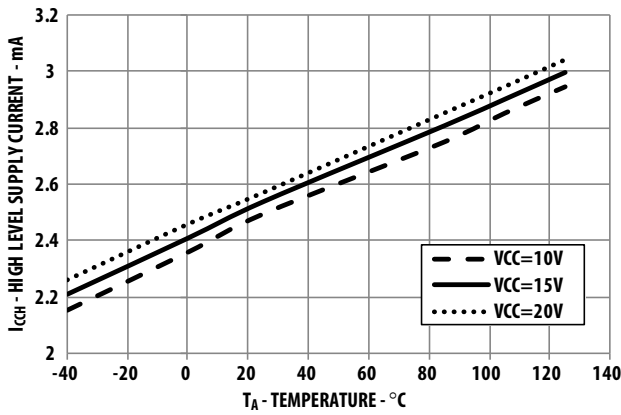

Figure 5. I_{CCH} vs. Temperature

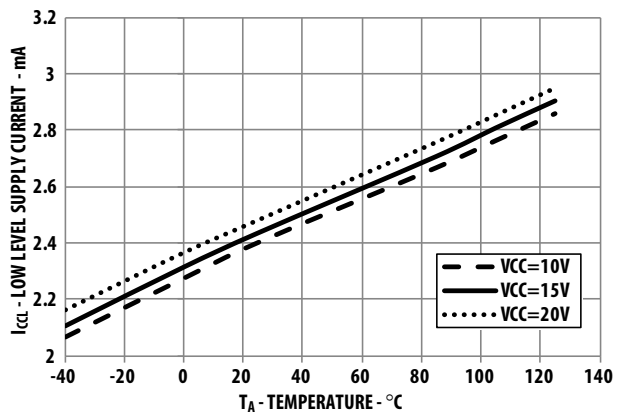

Figure 6. I_{CCL} vs. Temperature

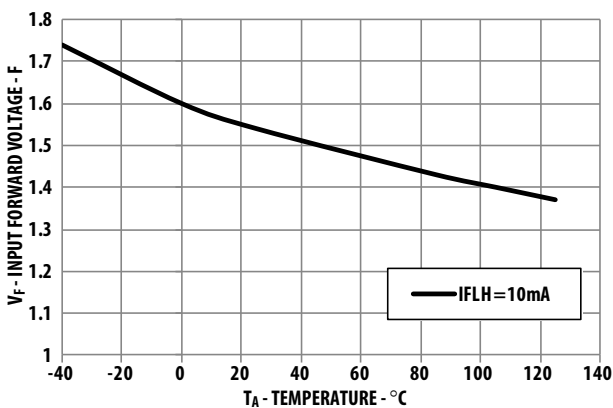

Figure 7. V_F vs. Temperature

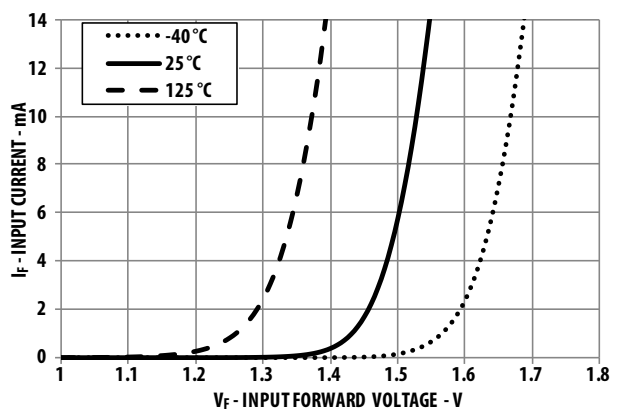

Figure 8. I_F vs. V_F

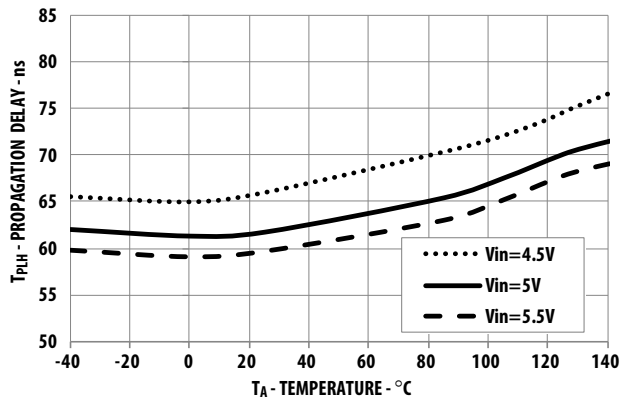

Figure 9. t_{pLH} vs. Temperature

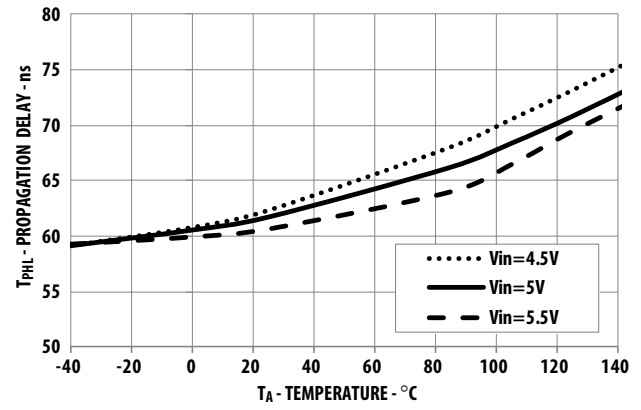

Figure 10. t_{pHL} vs. Temperature

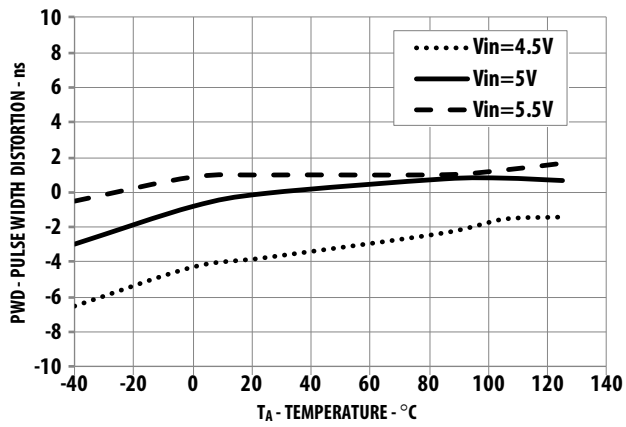

Figure 11. PWD vs. Temperature

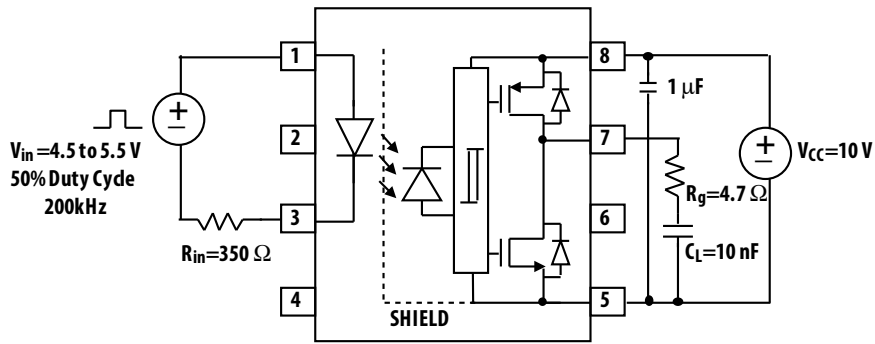

Figure 12. t_{PLH} and t_{PHL} test circuit

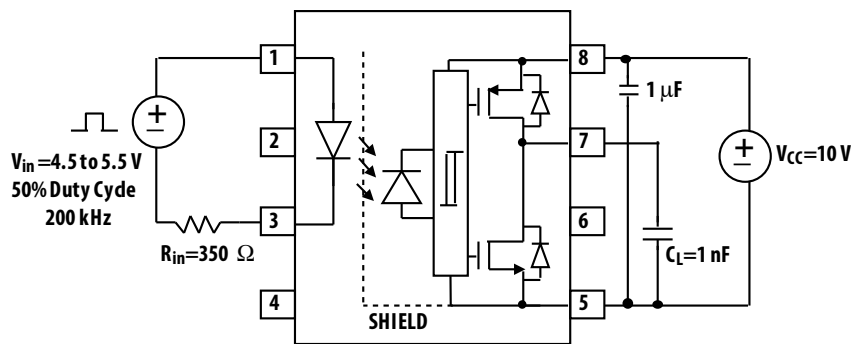

Figure 13. t_r and t_f test circuit

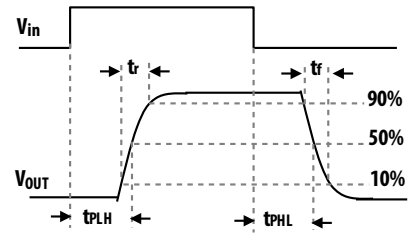
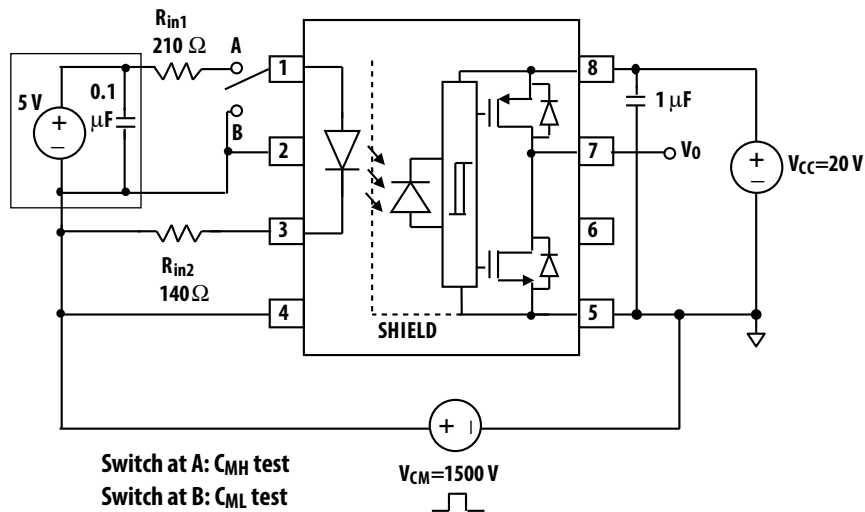

Figure 14. t_{PLH} , t_{PHL} , t_r and t_f reference waveforms



Switch at A: C_{MH} test
Switch at B: C_{ML} test

Figure 15. CMR test circuit

Application Information

Typical High Speed MOSFET Gate Drive Circuit

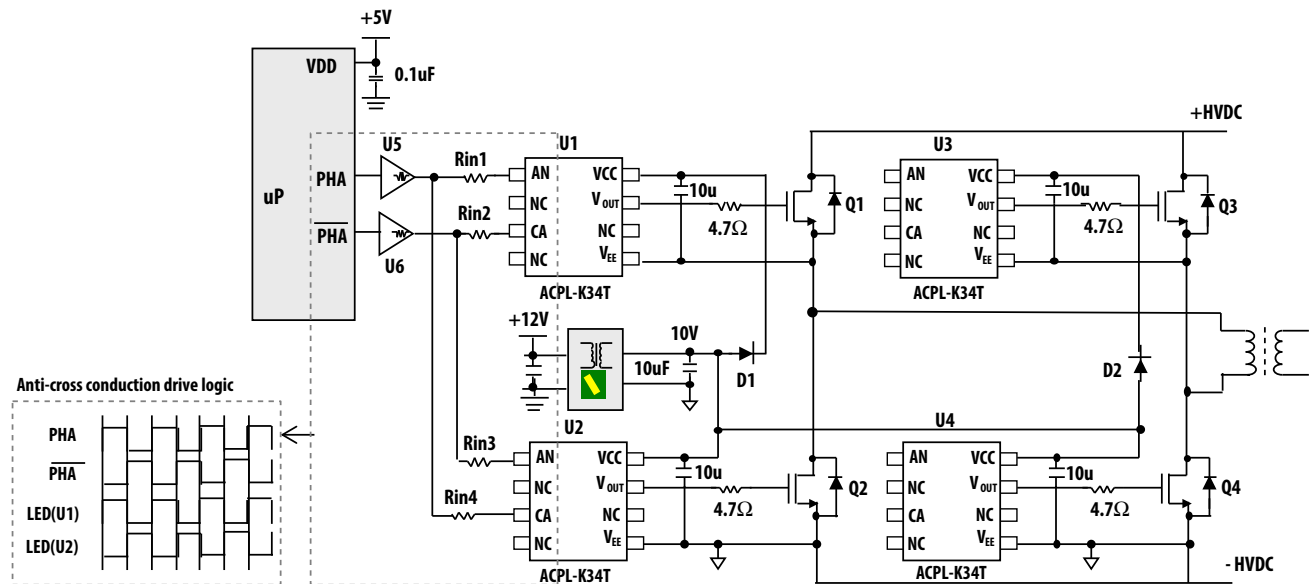

Figure 16. Typical high-speed MOSFET gate drive circuit

Anti-Cross Conduction Drive

One of the many benefits of using ACPL-K34T is the ease to implement anti-cross conduction drive between the high side and low side gate drivers to prevent shoot through event. This safety interlock drive can be realized by interlocking the output of buffer U5 and U6 to both high and low side gate drivers, as shown in Figure 16. However, due to the propagation delay difference between optocouplers, certain amount of dead time has to be added to ensure sufficient dead time at MOSFET gate. Refer to Dead Time and Propagation Delay section for more details.

Recommended LED Drive Circuits

Common mode noise exists whenever there is a difference in the ground level of the optocoupler's input control circuitry and output control circuitry. Figure 17 and 18 show recommended LED drive circuits for high common mode rejection (CMR) performance of the optocoupler gate driver. Split limiting resistors are used to balance the impedance at both anode and cathode of the input LED for high common mode noise rejection (see Figure 15).

Open drain and open collector drive circuits showed in Figure 19 are not recommended. During the off state of the MOSFET/transistor, cathode of the input LED sees high impedance and becomes sensitive to noise. In any cases, if designer still prefers to use single MOSFET/transistor drive over the recommended CMOS buffer drive showed in Figure 17 and 18, designer can choose alternative circuits showed in Figure 20; however M1/Q1 in Figure 20 drive circuits will shunt current during LED off state, which result in more power consumption.

Drive Power

If CMOS buffer is used to drive LED, it is recommended to connect the CMOS buffer at the LED cathode. This is because the sinking capability of the NMOS is usually more than the driving capability of the PMOS in a CMOS buffer.

Drive Logic

Designer can configure LED drive circuits for non-inverting and inverting logic as recommended in Figure 17 and 18. External power supply, V_{DD1} has to be connected to the CMOS buffer for the inverting and non-inverting logic to work. If V_{DD1} supply is lost, LED will be permanently off and output will be at low.

Bypass and Reservoir Capacitors

Supply bypass capacitors are necessary at the input buffer and ACPL-K34T output supply pin. A ceramic capacitor with the value of 0.1 μF is recommended at the input buffer, which also helps to improve CMR performance. At the output supply pin ($V_{CC} - V_{EE}$), it is recommended to use a 10 μF , low ESR and low ESL capacitor as a charge reservoir to supply instant driving current to MOSFET at V_{OUT} during switching.

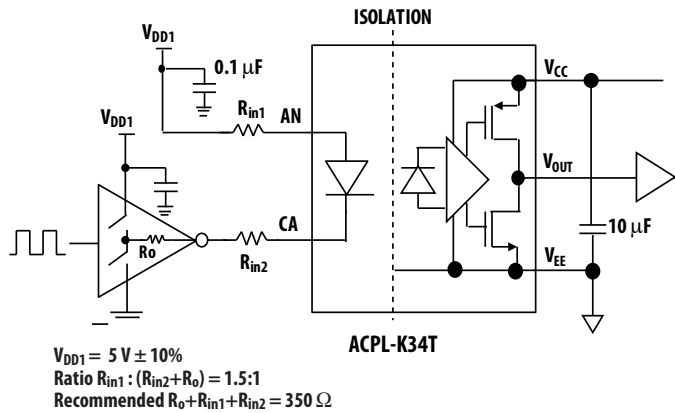

Figure 17. Recommended non-inverting drive circuit

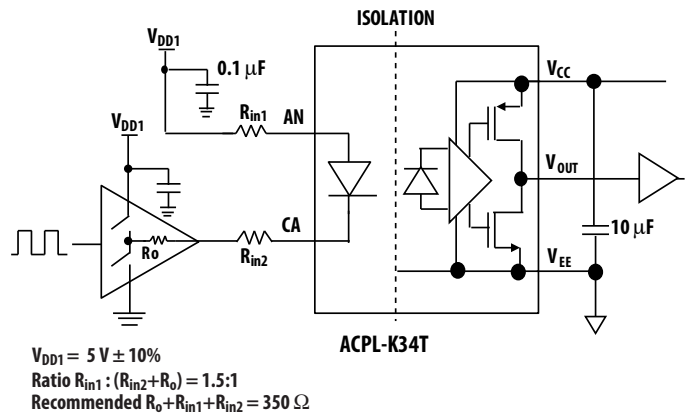

Figure 18. Recommended inverting drive circuit

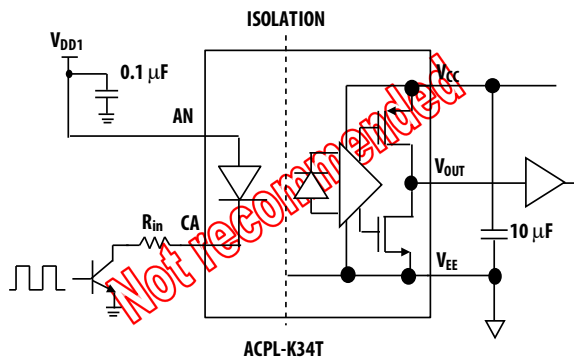

Figure 19(a)

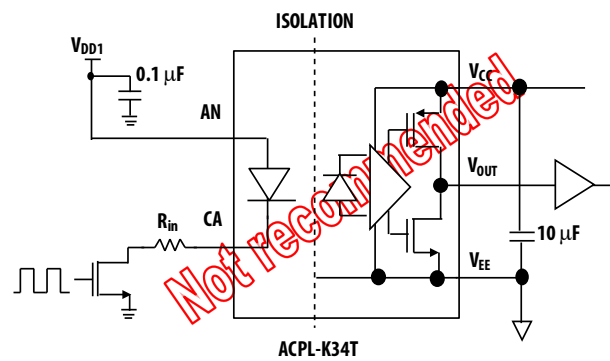

Figure 19(b)

Figure 19(a) and Figure 19(b). Not recommended – Open drain/open collector drive circuit

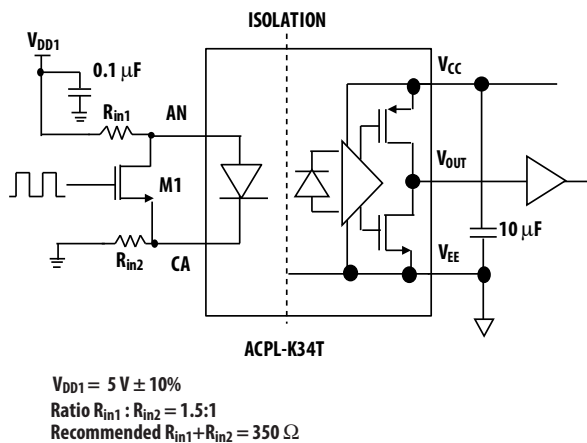

Figure 20(a)

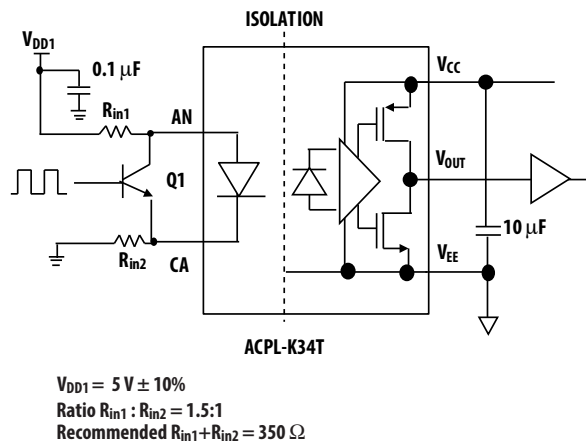

Figure 20(b)

Figure 20(a) and Figure 20(b). Alternative LED drive circuits to replace Figure 19(a) and 19(b)

Initial Power Up and UVLO Operation

Insufficient gate voltage to MOSFET can increase turn on resistance of MOSFET, resulting in large power loss and MOSFET damage due to high heat dissipation. ACPL-K34T monitors the output power supply constantly. During initial power up, the ACPL-K34T requires maximum 50 μ s of initial startup time for the internal bias and circuitry to get ready. The gate driver output (V_{OUT}) is hold at off state during initial startup time. Thereafter, when the output power supply is lower than under voltage lockout (V_{UVLO-}) threshold, gate driver output will shut off to protect MOSFET from low voltage bias. When the output power supply is more than the V_{UVLO+} threshold, V_{OUT} is released from low state and it follows the input LED drive signal, as shown in Figure 21.

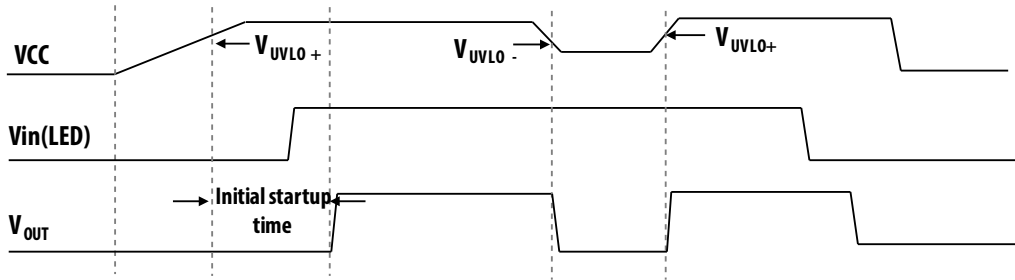

Figure 21. ACPL-K34T initial power-up and UVLO operation

Dead Time Distortion and Propagation Delay

Dead time is the period of time during which both high side and low side power transistors (shown as Q1 and Q2 in Figure 16) are off. Any overlap in Q1 and Q2 conduction will result in a shoot-through event and large short circuit current will flow through the power devices between the high side and low side power rail.

ACPL-K34T includes a Dead Time Distortion (DTD) specification intended to help designers optimize dead time in a power inverter design. A negative DTD value will decrease the system dead time, and so a negative DTD must be compensated by adding extra dead time to the design. Figure 22a shows that dead time after optocoupler is reduced by negative DTD. On the other hand, a positive DTD will add to the system original dead time, and so a positive DTD will cause dead time redundancy to the system. Figure 22b shows that dead time after optocoupler is increased by positive DTD.

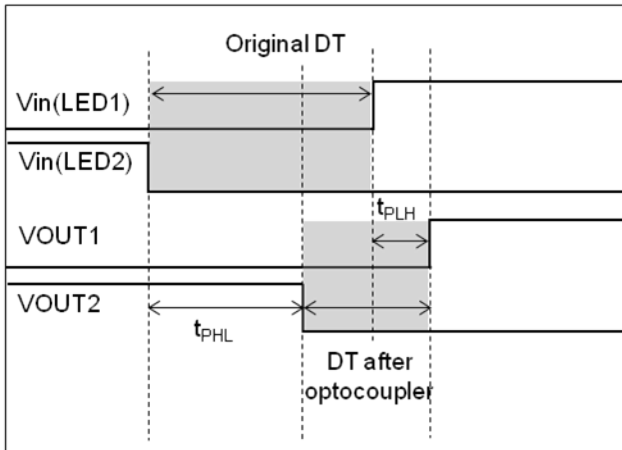

Figure 22a. Negative DTD reduces original DT

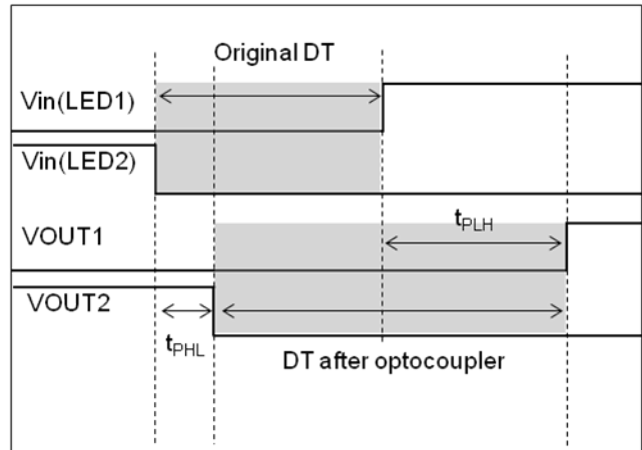

Figure 22b. Positive DTD increased original DT

Figure 22. Dead Time and Propagation Delay Waveforms

To prevent cross-conduction between high side and low side power transistors, minimum dead time (DT MIN) must be introduced to the system. For example, given DTD MIN = -40 ns and DTD MAX = 50 ns, if designers target to have minimum dead time (DT MIN) of 20 ns after the optocoupler, then initial dead time (DT) needed for the system can be calculated as:

$$\begin{aligned}DT &= DT \text{ MIN} - DTD \text{ MIN} \\ &= 20\text{ns} - (-40\text{ns}) \\ &= 60\text{ns}\end{aligned}$$

Maximum dead time (DT MAX) after the optocoupler can be calculated as:

$$\begin{aligned}DT \text{ MAX} &= DT + DTD \text{ MAX} \\ &= 60 \text{ ns} + 50 \text{ ns} \\ &= 110 \text{ ns}\end{aligned}$$

By introducing DT = 60 ns, the overall system dead time can vary from 20 ns to 110 ns due to the optocoupler's DTD.

Note: The propagation delays used to calculate dead time distortion (DTD) are taken at equal temperatures and test conditions since the optocouplers used are typically mounted close to each other and are switching the same type of MOSFETs.

Thermal Resistance Model for ACPL-K34T

The diagram for measurement is shown in Figure 23. Here, one die is heated first and the temperatures of all the dice are recorded after thermal equilibrium is reached. Then, the second die is heated and all the dice temperatures are recorded. With the known ambient temperature, the die junction temperature and power dissipation, the thermal resistance can be calculated. The thermal resistance calculation can be cast in matrix form. This yields a 2 by 2 matrix for our case of two heat sources.

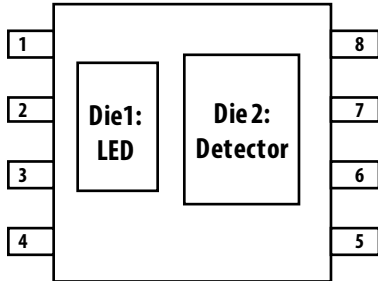

Figure 23. Diagram of ACPL-K34T for measurement

$$\begin{bmatrix} R11 & R12 \\ R21 & R22 \end{bmatrix} \cdot \begin{bmatrix} P1 \\ P2 \end{bmatrix} = \begin{bmatrix} \Delta T1 \\ \Delta T2 \end{bmatrix}$$

R11: Thermal Resistance of Die1 due to heating of Die1 (°C/W)

R12: Thermal Resistance of Die1 due to heating of Die2 (°C/W)

R21: Thermal Resistance of Die2 due to heating of Die1 (°C/W)

R22: Thermal Resistance of Die2 due to heating of Die2 (°C/W)

P1: Power dissipation of Die1 (W)

P2: Power dissipation of Die2 (W)

T1: Junction temperature of Die1 due to heat from all dice (°C)

T2: Junction temperature of Die2 due to heat from all dice (°C)

T_A: Ambient temperature (°C)

ΔT1: Temperature difference between Die 1 junction and ambient (°C)

ΔT2: Temperature difference between Die2 junction and ambient (°C)

$$T1 = (R11 \times P1 + R12 \times P2) + T_A \text{ -----(1)}$$

$$T2 = (R21 \times P1 + R22 \times P2) + T_A \text{ -----(2)}$$

Measurement is done on both low and high conductivity boards as shown below:

Layout	Measurement data	
	Low conductivity board:	High conductivity board:
	R11=191 °C/W R12=R21= 68.5°C/W R22=77°C/W	R11=155 °C/W R12=R21= 64°C/W R22=41°C/W

Note that the above thermal resistance R11, R12, R21 and R22 can be improved by increasing the ground plane/copper area.

Application and environment design for ACPL-K34T needs to ensure that the junction temperature of the internal IC and LED within the gate drive optocoupler do not exceed 150 °C. The equation (1) and (2) provided above are for the purposes of estimating the junction temperatures. For example:

Calculation of LED and output IC power dissipation

$$\begin{aligned} \text{LED power dissipation, } P_E &= I_{F(\text{LED})} (\text{Recommended Max}) * V_{F(\text{LED})} (\text{at } 125 \text{ }^\circ\text{C}) * \text{Duty Cycle} \\ &= 13 \text{ mA} * 1.25 \text{ V} * 50\% \\ &= 8.125 \text{ mW} \end{aligned}$$

$$\begin{aligned} \text{Output IC power dissipation, } P_O &= V_{CC} (\text{Recommended Max}) * I_{CC}(\text{Max}) + P_{HS} + P_{LS} \\ &= 20 \text{ V} * 4 \text{ mA} + 53.3 \text{ mW} + 32 \text{ mW} \\ &= 165.3 \text{ mW} \end{aligned}$$

where PHS = High side switching power dissipation

$$\begin{aligned} &= (V_{CC} * Q_G * f_{PWM}) * R_{DS,OH(\text{MAX})} / (R_{DS,OH(\text{MAX})} + R_{GH}) / 2 \\ &= (20 \text{ V} * 80\text{nC} * 200 \text{ kHz}) * 4\Omega / (4\Omega + 8\Omega) / 2 \\ &= 53.3\text{mW} \end{aligned}$$

PLS = Low side switching power dissipation

$$\begin{aligned} &= (V_{CC} * Q_G * f_{PWM}) * R_{DS,OL(\text{MAX})} / (R_{DS,OL(\text{MAX})} + R_{GL}) / 2 \\ &= (20 \text{ V} * 80 \text{ nC} * 200 \text{ kHz}) * 2\Omega / (2\Omega + 8\Omega) / 2 \\ &= 32 \text{ mW} \end{aligned}$$

Q_G = Gate charge at supply voltage

f_{PWM} = LED switching frequency

R_{GH} = Gate charging resistance

R_{GL} = Gate discharging resistance

Calculation of LED junction temperature and output IC junction temperature at $T_a=125 \text{ }^\circ\text{C}$:

LED junction temperature,

$$\begin{aligned} T_1 &= (R_{11} * P_E + R_{12} * P_O) + T_A \\ &= (191\text{ }^\circ\text{C/W} * 8.125 \text{ mW} + 68.5 \text{ }^\circ\text{C/W} * 165.3 \text{ mW}) + 125 \text{ }^\circ\text{C} \\ &= 138 \text{ }^\circ\text{C} < T_{J(\text{absolute max})} \text{ of } 150 \text{ }^\circ\text{C} \end{aligned}$$

Output IC junction temperature,

$$\begin{aligned} T_2 &= (R_{21} * P_E + R_{22} * P_O) + T_A \\ &= (68.5 \text{ }^\circ\text{C/W} * 8.125 \text{ mW} + 77 \text{ }^\circ\text{C/W} * 165.3 \text{ mW}) + 125 \text{ }^\circ\text{C} \\ &= 138 \text{ }^\circ\text{C} < T_{J(\text{absolute max})} \text{ of } 150 \text{ }^\circ\text{C} \end{aligned}$$

For product information and a complete list of distributors, please go to our web site: www.avagotech.com

Avago, Avago Technologies, the A logo, and R²Coupler are trademarks of Avago Technologies in the United States and other countries. Data subject to change. Copyright © 2005-2013 Avago Technologies. All rights reserved. AV02-4229EN - September 16, 2013

