

## Description

The ACS8522A is a highly integrated, single-chip solution for the Synchronous Equipment Timing Source (SETS) function in a SONET or SDH Network Element. The device generates SONET or SDH Equipment Clocks (SEC) and Frame Synchronization clocks. The ACS8522A is fully compliant with the required international specifications and standards.

The device supports Free-run, Locked and Holdover modes, with mode selection controlled either automatically by an internal state machine or forced by register configuration.

The ACS8522A accepts up to four independent input SEC reference clock sources from Recovered Line Clock, PDH network, and Node Synchronization. The ACS8522A generates independent SEC and BITS clocks, an 8 kHz Frame Synchronization clock and a 2 kHz Multi-Frame Synchronization clock, both with programmable pulse width and polarity.

The ACS8522A includes a Serial Port, which can be SPI compatible, providing access to the configuration and status registers for device setup.

The ACS8522A supports IEEE 1149.1<sup>[5]</sup> JTAG boundary scan.

The User can choose between OCXO or TCXO to define the Stratum and/or Holdover performance required.

## Features

- ◆ Suitable for Stratum 3, 4E, 4 and SONET Minimum Clock (SMC) or SONET/SDH Equipment Clock (SEC) applications (to Telcordia 1244-CORE<sup>[19]</sup> Stratum 3 and GR-253<sup>[17]</sup>, and ITU-T G.813<sup>[11]</sup> Options I and II specifications).
- ◆ Accepts four individual input reference clocks, all with robust input clock source quality monitoring.
- ◆ Simultaneously generates four output clocks, plus two Sync pulse outputs.
- ◆ Absolute Holdover accuracy better than  $3 \times 10^{-10}$  (manual),  $7.5 \times 10^{-14}$  (instantaneous); Holdover stability defined by choice of external XO.
- ◆ Programmable PLL bandwidth, for wander and jitter tracking/attenuation, 0.1 Hz to 70 Hz in 10 steps.
- ◆ Automatic hit-less source switchover on loss of input
- ◆ Serial SPI compatible interface.
- ◆ Output phase adjustment in 6 ps steps up to  $\pm 200$  ns
- ◆ IEEE 1149.1<sup>[5]</sup> JTAG Boundary Scan.
- ◆ Available in LQFP 64-pin package.
- ◆ Single 3.3 V operation.
- ◆ Lead (Pb)-free version available (ACS8522AT), RoHS and WEEE compliant.

## Block Diagram

Figure 1 Block Diagram of the ACS8522A SETS LITE

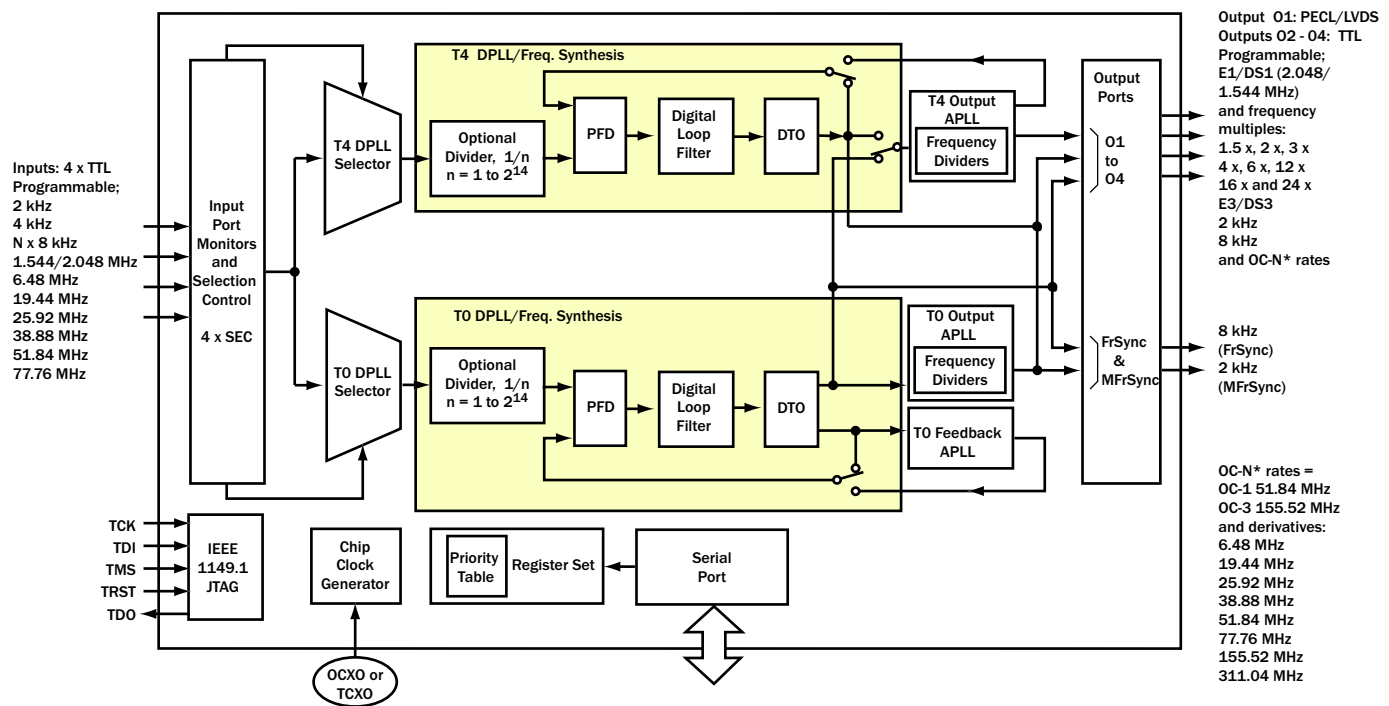

Table of Contents

Section	Page
Description .....	1
Block Diagram .....	1
Features .....	1
Pin Diagram .....	4
Pin Description .....	5
Introduction .....	7
General Description .....	7
Overview .....	7
Input Reference Clock Ports .....	9
Locking Frequency Modes .....	9
Clock Quality Monitoring .....	10
Activity Monitoring .....	11
Frequency Monitoring .....	12
Selection of Input Reference Clock Source .....	12
Forced Control Selection .....	13
Automatic Control Selection .....	13
Ultra Fast Switching .....	13
Fast External Switching Mode-SRC5W pin .....	13
Output Clock Phase Continuity on Source Switchover .....	14
Modes of Operation .....	14
Free-run Mode .....	14
Pre-locked Mode .....	14
Locked Mode .....	14
Lost-phase Mode .....	14
Holdover Mode .....	15
Pre-locked2 Mode .....	17
DPLL Architecture and Configuration .....	17
T0 DPLL Main Features .....	18
T4 DPLL Main Features .....	18
T0 DPLL Automatic Bandwidth Controls .....	18
Phase Detectors .....	18
Phase Lock/Loss Detection .....	19
Damping Factor Programmability .....	19
Local Oscillator Clock .....	20
Output Wander .....	20
Jitter and Wander Transfer .....	23
Phase Build-out .....	23
Input-to-Output Phase Adjustment .....	24
Input Wander and Jitter Tolerance .....	24
Using the DPLLs for Accurate Frequency and Phase Reporting .....	26
MFrSync and FrSync Alignment-SYNC2K .....	27
Output Clock Ports .....	27
PECL/LVDS Output Port Selection .....	27
Output Frequency Selection and Configuration .....	28
Power-On Reset .....	38
Serial Interface .....	38
Register Map .....	41
Register Organization .....	41
Register Access .....	41
Interrupt Enable and Clear .....	41
Defaults .....	41
Register Descriptions .....	45

<b>Section</b>	<b>Page</b>
Electrical Specifications .....	105
JTAG .....	105
Over-voltage Protection .....	105
ESD Protection .....	105
Latchup Protection.....	105
Maximum Ratings .....	106
Operating Conditions .....	106
DC Characteristics .....	106
Jitter Performance .....	109
Input/Output Timing .....	111
Package Information .....	112
Thermal Conditions .....	113
Application Information .....	114
References .....	115
Abbreviations .....	115
Trademark Acknowledgements .....	116
Revision Status/History .....	117
Ordering Information .....	118
Disclaimers.....	118
Contacts .....	118

Pin Diagram

Figure 2 ACS8522A Pin Diagram Synchronous Equipment Timing Source for Stratum 3/4E/4 and SMC Systems

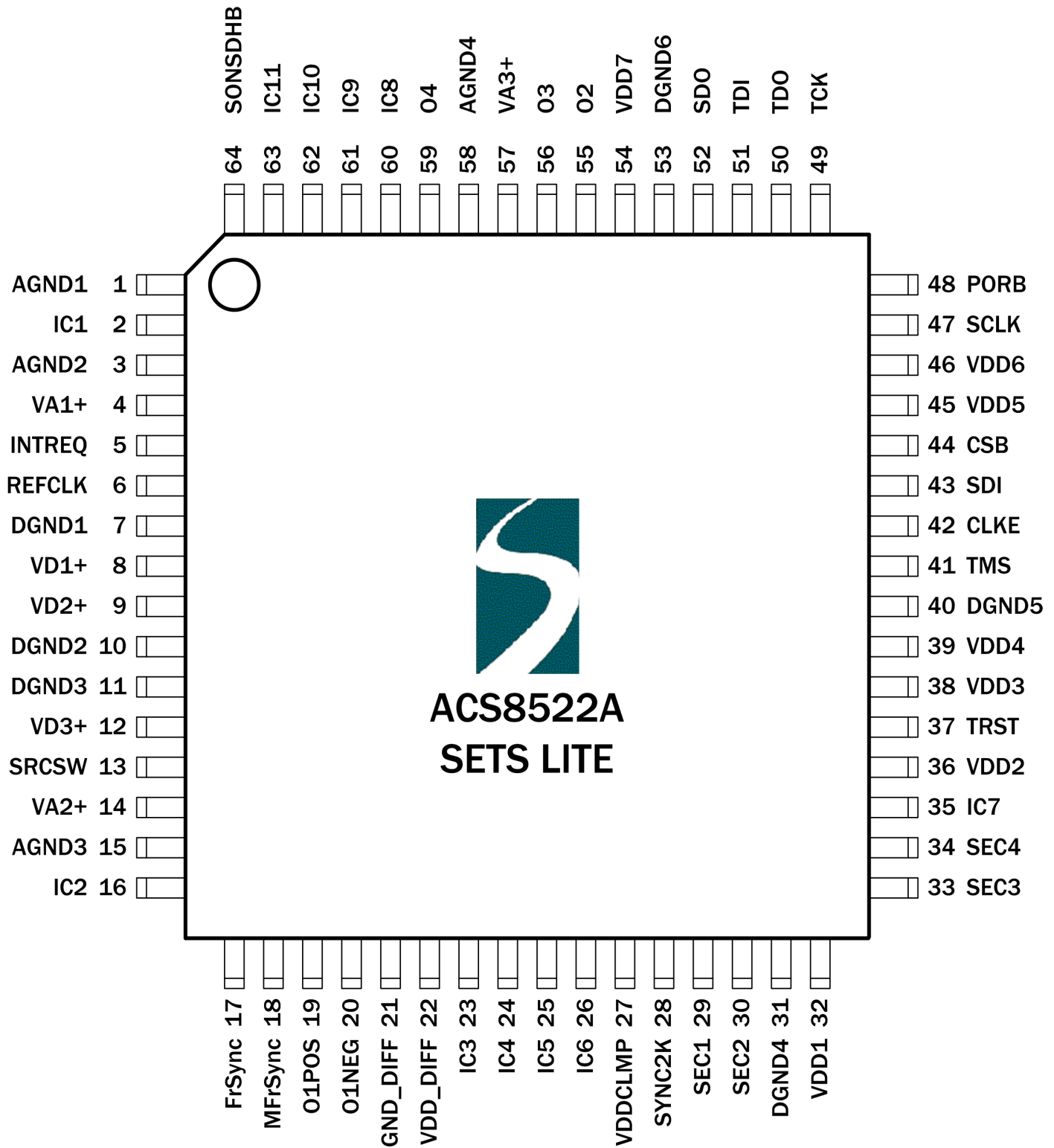

**Pin Description**
**Table 1 Power Pins**

Pin Number	Symbol	I/O	Type	Description
8, 9, 12	VD1+, VD2+, VD3+	P	-	Supply Voltage: Digital supply to gates in analog section, +3.3 Volts $\pm 5\%$ .
22	VDD_DIFF	P	-	Supply Voltage: Digital supply for differential output pins 19 and 20, +3.3 Volts $\pm 5\%$ .
27	VDDCLMP	P	-	Digital Supply for input over-voltage clamping to +3.3 volts. Leave floating for no clamping.
32, 36, 38, 39, 45, 46, 54	VDD1, VDD2, VDD3, VDD4, VDD5, VDD6, VDD7	P	-	Supply Voltage: Digital supply to logic, +3.3 Volts $\pm 5\%$ .
4	VA1+	P	-	Supply Voltage: Analog supply to clock multiplying PLL, +3.3 Volts $\pm 5\%$ .
14, 57	VA2+, VA3+	P	-	Supply Voltage: Analog supply to output PLLs APLL2 and APLL1, +3.3 Volts $\pm 5\%$ .
15, 58	AGND3, AGND4		-	Supply Ground: Analog ground for output PLLs APLL2 and APLL1.
7, 10, 11	DGND1, DGND2, DGND3	P	-	Supply Ground: Digital ground for components in PLLs.
31, 40, 53	DGND4, DGND5, DGND6	P	-	Supply Ground: Digital ground for logic.
21	GND_DIFF	P	-	Supply Ground: Digital ground for differential output pins 19 and 20.
1, 3	AGND1, AGND2	P	-	Supply Ground: Analog grounds.

Note...I = Input, O = Output, P = Power,  $TTL^U$  = TTL input with pull-up resistor,  $TTL_D$  = TTL input with pull-down resistor.

**Table 2 Internally Connected Pins**

Pin Number	Symbol	I/O	Type	Description
2, 16, 23, 24, 25, 26, 35, 60, 61, 62, 63	IC1, IC2, IC3, IC4, IC5, IC6, IC7, IC8, IC9, IC10, IC11	-	-	Internally Connected: Leave to Float.

**Table 3 Other Pins**

Pin Number	Symbol	I/O	Type	Description
5	INTREQ	O	TTL/CMOS	Interrupt Request: Active High/Low software Interrupt output.
6	REFCLK	I	TTL	Reference Clock: 12.800 MHz (refer to section headed Local Oscillator Clock).
13	SRCSW	I	$TTL_D$	Source Switching: Force Fast Source Switching on SEC1 and SEC2.

**Table 3 Other Pins (cont...)**

Pin Number	Symbol	I/O	Type	Description
17	FrSync	O	TTL/CMOS	Output Reference: 8 kHz Frame Sync output.
18	MFrSync	O	TTL/CMOS	Output Reference: 2 kHz Multi-Frame Sync output.
19, 20	O1POS, O1NEG	O	LVDS/PECL	Output Reference: Programmable, default 38.88 MHz, LVDS.
28	SYNC2K	I	TTL <sub>D</sub>	Multi-Frame Sync 2kHz input.
29	SEC1	I	TTL <sub>D</sub>	Input Reference: Programmable, default 8 kHz.
30	SEC2	I	TTL <sub>D</sub>	Input Reference: Programmable, default 8 kHz.
33	SEC3	I	TTL <sub>D</sub>	Input Reference: Programmable, default 19.44 kHz.
34	SEC4	I	TTL <sub>D</sub>	Input Reference: Programmable, default 19.44 kHz.
37	TRST	I	TTL <sub>D</sub>	JTAG Control Reset Input: TRST = 1 to enable JTAG Boundary Scan mode. TRST = 0 for Boundary Scan stand-by mode, still allowing correct device operation. If not used connect to GND or leave floating.
41	TMS	I	TTL <sub>D</sub>	JTAG Test Mode Select: Boundary Scan enable. Sampled on rising edge of TCK. If not used connect to VDD or leave floating.
42	CLKE	I	TTL <sub>D</sub>	SCLK Edge Select: SCLK active edge select, CLKE = 1, selects falling edge of SCLK to be active.
43	SDI	I	TTL <sub>D</sub>	Microprocessor Interface Address: Serial Data Input.
44	CSB	I	TTL <sup>U</sup>	Chip Select (Active Low): This pin is asserted Low by the microprocessor to enable the microprocessor interface.
47	SCLK	I	TTL <sub>D</sub>	Serial Data Clock. When this pin goes High data is latched from SDI pin.
48	PORB	I	TTL <sup>U</sup>	Power-On Reset: Master reset. If PORB is forced Low, all internal states are reset back to default values.
49	TCK	I	TTL <sub>D</sub>	JTAG Clock: Boundary Scan clock input.
50	TDO	O	TTL/CMOS	JTAG Output: Serial test data output. Updated on falling edge of TCK.
51	TDI	I	TTL <sub>D</sub>	JTAG Input: Serial test data Input. Sampled on rising edge of TCK.
52	SDO	O	TTL <sub>D</sub>	Interface Address: SPI compatible Serial Data Output.
55	O2	O	TTL/CMOS	Output Reference 2: Programmable, default 38.88 MHz.
56	O3	O	TTL/CMOS	Output Reference 3: Programmable, default 19.44 MHz.
59	O4	O	TTL/CMOS	Output Reference 4: Programmable, default 1.544/2.048 MHz (BITS).
64	SONSDHB	I	TTL <sub>D</sub>	SONET or SDH Frequency Select: Sets the initial power-up state (or state after a PORB) of the SONET/SDH frequency selection registers, Reg. 34 Bit 2, and Reg. 38 Bits 5 and 6. When set Low, SDH rates are selected (2.048 MHz etc.), and when set High, SONET rates are selected (1.544 MHz etc.). The register states can be changed after power-up by software.

## Introduction

The ACS8522A is a highly integrated, single-chip solution for the SETS function in a SONET/SDH Network Element, for the generation of SEC and Frame/MultiFrame sync pulses. Digital Phase Locked Loop (DPLL) and direct digital synthesis methods are used in the device so that the overall PLL characteristics are very stable and consistent compared to traditional analog PLLs.

In Free-run mode, the ACS8522A generates a stable, low-noise clock signal at a frequency to the same accuracy as the external oscillator, or it can be made more accurate via software calibration to within 0.02 ppm. In Locked mode, the ACS8522A selects the most appropriate input reference source and generates a stable, low-noise clock signal locked to the selected reference. In Holdover mode, the ACS8522A generates a stable, low-noise clock signal, adjusted to match the last known good frequency of the last selected reference source. A high level of phase and frequency accuracy is made possible by an internal resolution of up to 54 bits and internal Holdover accuracy of 0.0012 ppb ( $1.2 \times 10^{-12}$ ). In all modes, the frequency accuracy, jitter and drift performance of the clock meet the requirements of ITU G.736<sup>[7]</sup>, G.742<sup>[8]</sup>, G783<sup>[9]</sup>, G.812<sup>[10]</sup>, G.813<sup>[11]</sup>, G.823<sup>[13]</sup>, G.824<sup>[14]</sup> and Telcordia GR-253-CORE<sup>[17]</sup> and GR-1244-CORE<sup>[19]</sup>.

The ACS8522A supports all three types of reference clock source: recovered line clock, PDH network synchronization timing and node synchronization. The ACS8522A generates independent T0 and T4 clocks, an 8 kHz Frame Synchronization clock and a 2 kHz Multi-Frame Synchronization clock.

One key architectural advantage that the ACS8522A has over traditional solutions is in the use of DPLL technology for precise and repeatable performance over temperature or voltage variations and between parts. The overall PLL bandwidth, loop damping, pull-in range and frequency accuracy are all determined by digital parameters that provide a consistent level of performance. An Analog PLL (APLL) takes the signal from the DPLL output and provides a lower jitter output. The APLL bandwidth is set four orders of magnitude higher than the DPLL bandwidth. This ensures that the overall system performance still maintains the advantage of consistent behavior provided by the digital approach.

The DPLLs are clocked by the external Oscillator module (TCXO or OCXO) so that the Free-run or Holdover frequency stability is only determined by the stability of the external oscillator module. This second key advantage

confines all temperature critical components to one well defined and pre-calibrated module, whose performance can be chosen to match the application; for example an TCXO for Stratum 3 applications.

All performance parameters of the DPLLs are programmable without the need to understand detailed PLL equations. Bandwidth, damping factor and lock range can all be set directly, for example. The PLL bandwidth can be set over a wide range, 0.1 Hz to 70 Hz in 18 steps, to cover all SONET/SDH clock synchronization applications.

The ACS8522A includes a serial port, providing access to the configuration and status registers for device setup and monitoring.

## General Description

### Overview

The following description refers to the Block Diagram (Figure 1 on page 1).

The ACS8522A SETS device has four SEC clock inputs (SEC1 to SEC4), and generates four output clocks on outputs O1 to O4. The device offers a total of 55 possible output frequencies. There are two independent paths through the device: T0 path comprising T0 DPLL and T0 Output and Feedback APLLs, and T4 path comprising T4 DPLL and T4 Output APLL.

The T0 path is a high quality, highly configurable path designed to provide features necessary for node timing synchronization within a SONET/SDH network. The T4 path is a simpler and less configurable path designed to give a totally independent path for internal equipment synchronization. The device supports use of either or both paths, either locked together or independent.

The four SEC inputs ports are TTL/CMOS, 3 V compatible (with clamping if required by connecting the VDDCLMP pin). Refer to the electrical characteristics section for more information on the electrical compatibility and details. Input frequencies supported range from 2 kHz to 100 MHz.

Common E1, DS1, OC3 and sub-divisions are supported as spot frequencies that the DPLLs will directly lock to. Any input frequency, up to 100 MHz, that is a multiple of 8 kHz can also be locked to via an inbuilt programmable divider.

An input reference monitor is assigned to each of the four inputs. The monitors operate continuously such that at all times the status of all of the inputs to the device are known. Each input can be monitored for both frequency and activity, activity alone, or the monitors can be disabled.

The frequency monitors have a “hard” (rejection) alarm limit and a “soft” (flag only) alarm limit for monitoring frequency, whilst the reference is still within its allowed frequency band. Each input reference can be programmed with a priority number allowing references to be chosen according to the highest priority valid input. The two paths (T0 and T4) have independent priorities to allow completely independent operation of the two paths. Both paths operate either automatic or external source selection.

For automatic input reference selection, the T0 path has a more complex state machine than the T4 path.

The T0 and T4 PLL paths support the following common features:

- Automatic source selection according to input priorities and quality level
- Different quality levels (activity alarm thresholds) for each input
- Variable bandwidth, lock range and damping factor
- Direct PLL locking to common SONET/SDH input frequencies or any integer multiple of 8 kHz up to 100 MHz
- Automatic mode switching between Free-run, Locked and Holdover states
- Fast detection on input failure and entry into Holdover mode (holds at the last good frequency value)
- Frequency translation between input and output rates via direct digital synthesis
- High accuracy digital architecture for stable PLL dynamics combined with an APLL for low jitter final output clocks.

There are a number of features supported by the T0 path that are not supported by the T4 path, although these can also all be externally controlled by software.

The additional T0 features supported are:

- Non-revertive mode
- Phase Build-out on source switch (hit-less source switching)
- I/O phase offset control

- Greater programmable bandwidth from 0.1 Hz to 70 Hz in 10 steps (T4 path programmable bandwidth in 3 steps, 18, 35 and 70 Hz)
- Noise rejection on low frequency input
- Manual Holdover frequency control
- Controllable automatic Holdover frequency filtering
- Frame Sync pulse alignment.

Either the software or an internal state machine controls the operation of the DPLL in the T0 path. The state machine for the T4 path is very simple and cannot be manually/externally controlled, however the overall operation can be controlled by manual reference source selection. One additional feature of the T4 path is the ability to measure a phase difference between two inputs.

The T0 path DPLL always produces an output at 77.76 MHz to feed the APLL, regardless of the frequency selected at the output pins. The T4 path can be operated at a number of frequencies. This is to enable the generation of extra output frequencies, which cannot be easily related to 77.76 MHz. When the T4 path is selected to lock to the T0 path, the T4 DPLL locks to the 8 kHz from the T0 DPLL. This is because all of the frequencies of operation of the T4 path can be divided to 8 kHz and this will ensure synchronization of all the frequencies within the two paths.

Both of the DPLLs’ outputs are connected to multiplying and filtering APLLs. The outputs of these APLLs are divided making a number of frequencies simultaneously available for selection at the output clock ports. The various combinations of DPLL, APLL and divider configurations allow for generation of a comprehensive set of frequencies as listed in Table 12).

To synchronize the lower output frequencies when the T0 PLL is locked to a high frequency reference input, an additional input is provided. The SYNC2K pin (pin 28) is used to reset the dividers that generate the 2 kHz and 8 kHz outputs such that the output 2/8 kHz clocks are lined up with the input 2 kHz. This synchronization method could allow for example, a master and a slave device to be in precise alignment.

The ACS8522A also supports Sync pulse references of 4 kHz or 8 kHz although in these cases frequencies lower than the Sync pulse reference may not necessarily be in phase.



### Input Reference Clock Ports

Table 4 gives details of the input reference ports, showing the input technologies and the range of frequencies supported on each port; the default spot frequencies and default priorities assigned to each port on power-up or by reset are also shown. Note that SDH and SONET networks use different default frequencies; the network type is pin-selectable (using either the SONSDHB pin or via software). Specific frequencies and priorities are set by configuration.

The input ports are fully interchangeable.

SDH and SONET networks use different default frequencies; the network type is selectable using *cnfg\_input\_mode* Reg. 34, Bit 2 *ip\_sonsdhb*.

- For SONET, *ip\_sonsdhb* = 1
- For SDH, *ip\_sonsdhb* = 0

On power-up or by reset, the default will be set by the state of the SONSDHB pin (pin 64). Specific frequencies and priorities are set by configuration.

The frequency selection is programmed via the *cnfg\_ref\_source\_frequency* register (Reg. 22, 22, 27 and 28).

**Table 4 Input Reference Source Selection and Priority Table**

Input Port	Channel Number (Bin)	Input Port Technology	Frequencies Supported	Default Priority
SEC1	0011	TTL/CMOS	Up to 100 MHz (see Note (i)) Default (SONET): 8 kHz Default (SDH): 8 kHz	2
SEC2	0100	TTL/CMOS	Up to 100 MHz (see Note (i)) Default (SONET): 8 kHz Default (SDH): 8 kHz	3
SEC3	1000	TTL/CMOS	Up to 100 MHz (see Note (i)) Default (SONET): 19.44 MHz Default (SDH): 19.44 MHz	4
SEC4	1001	TTL/CMOS	Up to 100 MHz (see Note (i)) Default (SONET): 19.44 MHz Default (SDH): 19.44 MHz	5

Note: (i) TTL ports (compatible also with CMOS signals) support clock speeds up to 100 MHz, with the highest spot frequency being 77.76 MHz. The actual spot frequencies are: 2 kHz, 4 kHz, 8 kHz (and  $N \times 8$  kHz), 1.544 MHz (SONET)/2.048 MHz (SDH), 6.48 MHz, 19.44 MHz, 25.92 MHz, 38.88 MHz, 51.84 MHz, 77.76 MHz. SONET or SDH input rate is selected via Reg. 34 Bit 2, *ip\_sonsdhb*.

### Locking Frequency Modes

There are three locking frequency modes that can be configured: Direct Lock, Lock 8k and DivN.

#### Direct Lock Mode

In Direct Lock Mode, the internal DPLL can lock to the selected input at the spot frequency of the input, for example 19.44 MHz performs the DPLL phase comparisons at 19.44 MHz.

In Lock8K and DivN modes an internal divider is used prior to the DPLL to divide the input frequency before it is used for phase comparisons in the DPLL.

#### Lock8K Mode

Lock8K mode automatically sets the divider parameters to divide the input frequency down to 8 kHz. Lock8K can only be used on the supported spot frequencies (see Table 4 Note(i)). Lock8k mode is enabled by setting the *Lock8k* bit (Bit 6) in the appropriate *cnfg\_ref\_source\_frequency* register location. Using lower frequencies for phase comparisons in the DPLL results in a greater tolerance to input jitter. It is possible to choose which edge of the input reference clock to lock to, by setting *8K edge polarity* (Bit 2 of Reg. 03, *test\_register1*).

**DivN Mode**

In DivN mode, the divider parameters are set manually by configuration (Bit 7 of the *cnfg\_ref\_source\_frequency* register), but must be set so that the frequency after division is 8 kHz. The DivN function is defined as:

DivN = "Divide by N+ 1", i.e. it is the dividing factor used for the division of the input frequency, and has a value of (N+1) where N is an integer from 1 to 12499 inclusive. Therefore, in DivN mode the input frequency can be divided by any integer value between 2 to 12500. Consequently, any input frequency which is a multiple of 8 kHz, between 8 kHz to 100 MHz, can be supported by using DivN mode.

*Note...Any reference input can be set to use DivN independently of the frequencies and configurations of the other inputs. However only one value of N is allowed, so all inputs with DivN selected must be running at the same frequency.*

**DivN Examples**

(a) To lock to 2.000 MHz:

- (i) Set the *cnfg\_ref\_source\_frequency* register to 10XX0000 (binary) to enable DivN, and set the frequency to 8 kHz - the frequency required after division. (XX = "Leaky Bucket" ID for this input).
- (ii) To achieve 8 kHz, the 2 MHz input must be divided by 250. So, if  $\text{DivN} = 250 = (N + 1)$  then N must be set to 249. This is done by writing F9 hex (249 decimal) to the DivN register pair Reg. 46/47.

(b) To lock to 10.000 MHz:

- (i) The *cnfg\_ref\_source\_frequency* register is set to 10XX0000 (binary) to set the DivN and the frequency to 8 kHz, the post-division frequency. (XX = "Leaky Bucket" ID for this input).
- (ii) To achieve 8 kHz, the 10 MHz input must be divided by 1,250. So, if  $\text{DivN} = 250 = (N+1)$  then N must be set to 1,249. This is done by writing 4E1 hex (1,249 decimal) to the DivN register pair Reg. 46/47.

**Clock Quality Monitoring**

Clock quality is monitored and used to modify the priority tables. The following parameters are monitored:

1. Activity (togglng).
2. Frequency (this monitoring is only performed when there is no irregular operation of the clock or loss of clock condition).

Any reference source that suffers a loss-of-activity or clock-out-of-band condition will be declared as unavailable.

Clock quality monitoring is a continuous process which is used to identify clock problems. There is a difference in dynamics between the selected clock and the other reference clocks. Anomalies occurring on non-selected reference sources affect only that source's suitability for selection, whereas anomalies occurring on the selected clock could have a detrimental impact on the accuracy of the output clock.

Anomalies detected by the activity detector are integrated in a Leaky Bucket Accumulator. Occasional anomalies do not cause the Accumulator to cross the alarm setting threshold, so the selected reference source is retained. Persistent anomalies cause the alarm setting threshold to be crossed and result in the selected reference source being rejected.

Anomalies on the currently locked-to input reference clock, whether affecting signal purity or signal frequency, could induce jitter or frequency offsets in the output clock, leading to anomalous behavior. Anomalies on the selected clock, therefore, have to be detected as they occur and the phase locked loop must be temporarily isolated until the clock is once again pure. The clock monitoring process cannot be used for this because the high degree of accuracy required dictates that the process be slow. To achieve the immediacy required by the phase locked loop requires an alternative mechanism.

The phase locked loop itself contains a fast activity detector such that within approximately two missing input clock cycles, a no-activity flag is raised and the DPLL is frozen in Holdover mode. This flag can also be read as the *main\_ref\_failed* bit (from Reg. 06, Bit 6) and can be set to indicate a phase lost state by enabling Reg. 73, Bit 6. With the DPLL in Holdover mode it is isolated from further disturbances. If the input becomes available again before the activity or frequency monitor rejection alarms have

been raised, then the DPLL will continue to lock to the input, with little disturbance. In this scenario, with the DPLL in the “locked” state, the DPLL uses “nearest edge locking” mode ( $\pm 180^\circ$  capture) avoiding cycle slips or glitches caused by trying to lock to an edge  $360^\circ$  away, as would happen with traditional PLLs.

### Activity Monitoring

The ACS8522A has a combined inactivity and irregularity monitor. The ACS8522A uses a Leaky Bucket Accumulator, which is a digital circuit which mimics the operation of an analog integrator, in which input pulses increase the output amplitude but die away over time. Such integrators are used when alarms have to be triggered either by fairly regular defect events, which occur sufficiently close together, or by defect events which occur in bursts. Events which are sufficiently spread out should not trigger the alarm. By adjusting the alarm setting threshold, the point at which the alarm is triggered can be controlled. The point at which the alarm is cleared depends upon the decay rate and the alarm clearing threshold.

On the alarm setting side, if several events occur close together, each event adds to the amplitude and the alarm will be triggered quickly; if events occur further apart, but still sufficiently close together to overcome the decay, the alarm will be triggered eventually. If events occur at a rate which is not sufficient to overcome the decay, the alarm will not be triggered. On the alarm clearing side, if no defect events occur for a sufficient time, the amplitude will decay gradually and the alarm will be cleared when the amplitude falls below the alarm clearing threshold. The ability to decay the amplitude over time allows the importance of defect events to be reduced as time passes by. This means that, in the case of isolated events, the alarm will not be set, whereas, once the alarm becomes set, it will be held on until normal operation has persisted for a suitable time (but if the operation is still erratic, the alarm will remain set). See Figure 3.

There is one Leaky Bucket Accumulator per input channel. Each Leaky Bucket can select from four Configurations (Leaky Bucket Configuration 0 to 3). Each Leaky Bucket Configuration is programmable for size, alarm set and reset thresholds, and decay rate.

Each source is monitored over a 128 ms period. If, within a 128 ms period, an irregularity occurs that is not deemed to be due to allowable jitter/wander, then the Accumulator is incremented.

The Accumulator will continue to increment up to the point that it reaches the programmed Bucket size. The “fill rate” of the Leaky Bucket is, therefore, 8 units/second. The “leak rate” of the Leaky Bucket is programmable to be in multiples of the fill rate (x 1, x 0.5, x 0.25 and x 0.125) to give a programmable leak rate from 8 units/sec down to 1 unit/sec. A conflict between trying to “leak” at the same time as a “fill” is avoided by preventing a leak when a fill event occurs.

Disqualification of a non-selected reference source is based on inactivity, or on an out-of-band result from the frequency monitors. The currently selected reference source can be disqualified for phase, frequency, inactivity or if the source is outside the DPLL lock range. If the currently selected reference source is disqualified, the next highest priority, qualified reference source is selected.

### Interrupts for Activity Monitors

The loss of the currently selected reference source will eventually cause the input to be considered invalid, triggering an interrupt, if not masked. The time taken to raise this interrupt is dependent on the Leaky Bucket Configuration of the activity monitors. The fastest Leaky Bucket setting will still take up to 128 ms to trigger the interrupt. The interrupt caused by the brief loss of the currently selected reference source is provided to facilitate very fast source failure detection if desired. It is triggered after missing just a couple of cycles of the reference source. Some applications require the facility to switch downstream devices based on the status of the reference sources. In order to provide extra flexibility, it is possible to flag the *main\_ref\_failed* interrupt (Reg. 06 Bit 6) on the pin TDO. This is simply a copy of the status bit in the interrupt register and is independent of the mask register settings. The bit is reset by writing to the interrupt status register in the normal way. This feature can be enabled and disabled by writing to Reg. 48 Bit 6.

Figure 3 Inactivity and Irregularity Monitoring

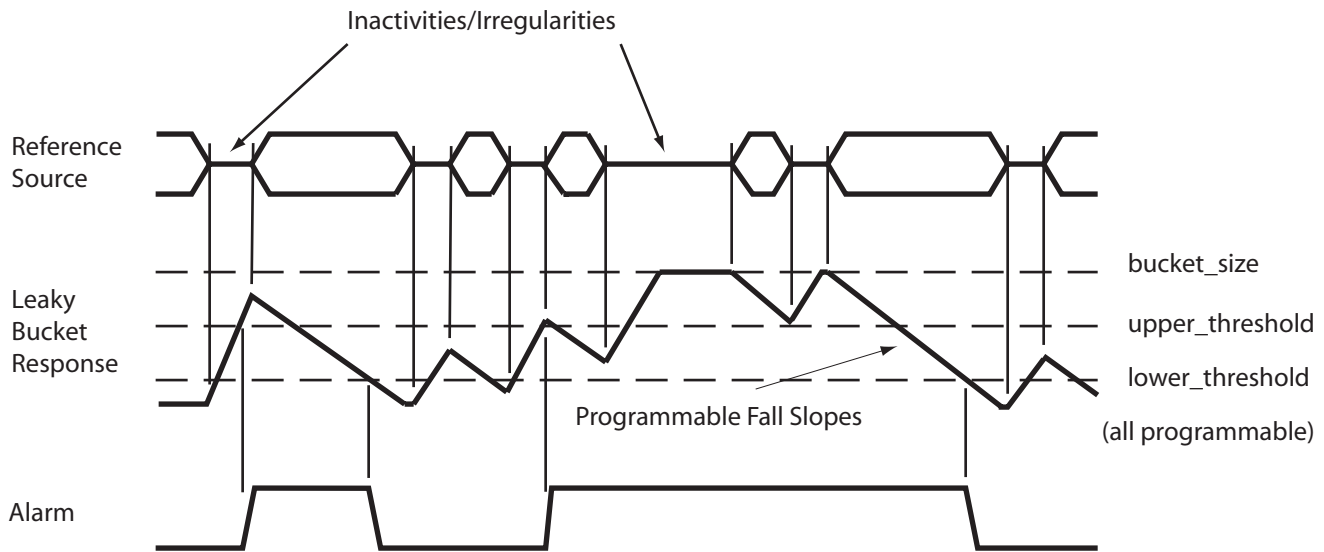

**Leaky Bucket Timing**

The time taken (in seconds) to raise an inactivity alarm on a reference source that has previously been fully active (Leaky Bucket empty) will be:

$$(cnfg\_upper\_threshold\_n) / 8$$

where n is the number of the Leaky Bucket Configuration. If an input is intermittently inactive then this time can be longer. The default setting of *cnfg\_upper\_threshold* is 6, therefore the default time is 0.75 s.

The time taken (in seconds) to cancel the activity alarm on a previously completely inactive reference source is calculated, for a particular Leaky Bucket, as:

$$[2^{(a)} \times (b - c)] / 8$$

where:

- a = *cnfg\_decay\_rate\_n*
- b = *cnfg\_bucket\_size\_n*
- c = *cnfg\_lower\_threshold\_n*

(where n = the number of the relevant Leaky Bucket Configuration in each case).

The default setting is shown in the following:

$$[2^1 \times (8 - 4)] / 8 = 1.0 \text{ secs}$$

**Frequency Monitoring**

The ACS8522A performs input frequency monitoring to identify reference sources which have drifted outside the acceptable frequency range measured with respect either to the output clock or to the XO clock.

The *sts\_reference\_sources* out-of-band alarm for a particular reference source is raised when the reference source is outside the acceptable frequency range. With the default register settings a soft alarm is raised if the drift is outside  $\pm 11.43$  ppm and a hard alarm is raised if the drift is outside  $\pm 15.24$  ppm. Both of these limits are programmable from 3.8 ppm up to 61 ppm.

The ACS8522A DPLL has a programmable lock and capture range frequency limit up to  $\pm 80$  ppm (default is  $\pm 9.2$  ppm).

**Selection of Input Reference Clock Source**

Under normal operation, the input reference sources are selected automatically by an order of priority. But, for special circumstances, such as chip or board testing, the selection may be forced by configuration.

Automatic operation selects a reference source based on its pre-defined priority and its current availability. A table is maintained which lists all reference sources in the order of priority. This is initially defined by the default configuration and can be changed via the Serial interface by the Network Manager. In this way, when all the defined sources are active and valid, the source with the highest programmed priority is selected but, if this source fails, the next-highest source is selected, and so on.

Restoration of repaired reference sources is handled carefully to avoid inadvertent disturbance of the output clock. For this, the ACS8522A has two modes of operation; Revertive and Non-revertive.

In Revertive mode, if a re-validated (or newly validated) source has a higher priority than the reference source which is currently selected, a switch over will take place. Many applications prefer to minimize the clock switching events and choose Non-revertive mode.

In Non-revertive mode, when a re-validated (or newly validated) source has a higher priority than the selected source will be maintained. The re-validation of the reference source will be flagged in the *sts\_sources\_valid* register (Reg. OE and OF) and, if not masked, will generate an interrupt. Selection of the re-validated source can take place under software control or if the currently selected source fails.

To enable software control, the software should briefly enable Revertive mode to effect a switch-over to the higher priority source. When there is a reference available with higher priority than the selected reference, there will be NO change of reference source as long as the Non-revertive mode remains on, and the currently selected source is valid. A failure of the selected reference will always trigger a switch-over regardless of whether Revertive or Non-revertive mode has been chosen.

### Forced Control Selection

A configuration register, *force\_select\_reference\_source* Reg. 33, controls both the choice of automatic or forced selection and the selection itself (when forced selection is required). For Automatic choice of source selection, the four LSB bit value is set to all zeros or all ones (default). To force a particular input the bit value must be set as follows: 0011 forces SEC1, 0100 forces SEC2, 1000 forces SEC3 and 1001 forces SEC4. Forced selection is not the normal mode of operation, and the *force\_select\_reference\_source* variable is defaulted to the all-one value on reset, thereby adopting the automatic selection of the reference source.

### Automatic Control Selection

When an automatic selection is required, the *force\_select\_reference\_source* register LSB four bits must be set to all zeros or all ones. The configuration registers, *cnfg\_ref\_selection\_priority* (Reg. 19, 1B and 1C), hold 4-bit values which represents the desired priority of that particular port. Unused ports should be given the value 0000 in the relevant register to indicate they are not to be included in the priority table. On power-up, or following a reset, the whole of the configuration file will be defaulted to the values defined

by Table 4. The selection priority values are all relative to each other, with lower-valued numbers taking higher priorities. Each reference source should be given a unique number; the valid values are 1 to 15 (dec). A value of zero disables the reference source. However if two or more inputs are given the same priority number those inputs will be selected on a first in, first out basis. If the first of two same priority number sources goes invalid the second will be switched in. If the first then becomes valid again, it becomes the second source on the first in, first out basis, and there will not be a switch. If a third source with the same priority number as the other two becomes valid, it joins the priority list on the same first in, first out basis. There is no implied priority based on the channel numbers. Revertive/Non-revertive mode has no effect on sources with the same priority value.

### Ultra Fast Switching

A reference source is normally disqualified after the Leaky Bucket monitor thresholds have been crossed. An option for a faster disqualification has been implemented, whereby if Reg. 48 Bit 5 (*ultra\_fast\_switch*) is set, then a loss of activity of just a few reference clock cycles will set the *main\_ref\_failed* alarm and cause a reference switch. This can be configured (see Reg. 06, Bit 6) to cause an interrupt to occur instead of, or as well as, causing the reference switch.

The *sts\_interrupts* register Reg. 06 Bit 6 (*main\_ref\_failed*) is used to flag inactivity on the reference that the device is locked to much faster than the activity monitors can support. If Reg. 48 Bit 6 of the *cnfg\_monitors* register (*los\_flag\_on\_TDO*) is set, then the state of this bit is driven onto the TDO pin of the device.

*Note... The flagging of the loss of the main reference failure on TDO is simply allowing the status of the *sts\_interrupts* bit *main\_ref\_failed* (Reg. 06, Bit 6) to be reflected in the state of the TDO output pin. The pin will, therefore, remain High until the interrupt is cleared. This functionality is not enabled by default so the usual JTAG functions can be used. When the TDO output from the ACS8522A is connected to the TDI pin of the next device in the JTAG scan chain, the implementation should be such that a logic change caused by the action of the interrupt on the TDI input should not effect the operation when JTAG is not active.*

### Fast External Switching Mode-SRCSW pin

Fast External Switching mode allows fast switching between inputs SEC1 and SEC2 only. The mode must first be enabled before switching can take place, and then switching is controlled via the SRCSW pin.

There are two ways to enable Fast External Switching mode:

- Mode enable by register write - by writing to Reg. 48 Bit 4, or
- Mode enable by hardware “initialization” - by holding SRCSW *High* throughout reset and for at least a further 251 ms after PORB has gone *High* (250 ms allowance for the internal reset to be removed plus 1 ms allowance for APLLs to start-up and become stable). A simple external circuit to set SRCSW high for the required period is shown in “Simplified Application Schematic” on page 114. If SRCSW pin is held *Low* at any time during the 251 ms initialization period, this may result in Fast External Switching mode not being enabled correctly.

Once Fast External Switching mode is enabled, then the value of the SRCSW pin directly selects either SEC1 (SRCSW *High*) or SEC2 (SRCSW *Low*). If this mode is enabled by hardware initialization, then it configures the default frequency tolerance of SEC1 and SEC2 to  $\pm 80$  ppm (Reg. 41 and 42). Either of these registers can be subsequently reconfigured by external software, if required.

When Fast External Switching mode is enabled, the device operates as a simple switch. All clock monitoring is disabled and the DPLL will simply be forced to try to lock on to the indicated reference source. Consequently the device will always indicate “locked” state in the *sts\_operating* register (Reg. 09, Bits 2:0).

### Output Clock Phase Continuity on Source Switchover

If either PBO is selected on (default), or, if DPLL frequency limit is set to less than  $\pm 30$  ppm or ( $\pm 9.2$  ppm default), the device will always comply with GR-1244-CORE<sup>[19]</sup> specification for Stratum 3 (maximum rate of phase change of 81 ns/1.326 ms), for all input frequencies.

### Modes of Operation

The ACS8522A has three primary modes of operation (Free-run, Locked and Holdover) supported by three secondary, temporary modes (Pre-locked, Lost-phase and Pre-locked2). These are shown in the State Transition Diagram, Figure 4.

The ACS8522A can operate in Forced or Automatic control. On reset, the ACS8522A reverts to Automatic Control, where transitions between states are controlled

completely automatically. Forced Control can be invoked by configuration, allowing transitions to be performed under external control. This is not the normal mode of operation, but is provided for special occasions such as testing, or where a high degree of hands-on control is required.

### Free-run Mode

The Free-run mode is typically used following a power-on-reset or a device reset before network synchronization has been achieved. In the Free-run mode, the timing and synchronization signals generated from the ACS8522A are based on the 12.800 MHz clock frequency provided from the external oscillator and are not synchronized to an input reference source. By default, the frequency of the output clock is a fixed multiple of the frequency of the external oscillator, and the accuracy of the output clock is equal to the accuracy of the oscillator. However the external oscillator frequency can be calibrated to improve its accuracy by a software calibration routine using register *cnfg\_nominal\_frequency* (Reg. 3C and 3D). For example a 500 ppm offset crystal could be made to look like one accurate to within  $\pm 0.02$  ppm.

The transition from Free-run to Pre-locked occurs when the ACS8522A selects a reference source.

### Pre-locked Mode

The ACS8522A will enter the Locked state in a maximum of 100 seconds, as defined by GR-1244-CORE<sup>[19]</sup> specification, if the selected reference source is of good quality. If the device cannot achieve lock within 100 seconds, it reverts to Free-run mode and another reference source is selected.

### Locked Mode

The Locked mode is entered from Pre-locked, Pre-locked2 or Phase-lost mode when an input reference source has been selected and the DPLL has locked. The DPLL is considered to be locked when the phase loss/lock detectors (See “Phase Lock/Loss Detection” on page 19) indicate that the DPLL has remained in phase lock continuously for at least one second. When the ACS8530 is in Locked mode, the output frequency and phase tracks that of the selected input reference source.

### Lost-phase Mode

Lost-phase mode is used whenever the phase loss/lock detectors (See “Phase Lock/Loss Detection” on page 19)

indicate that the DPLL has lost phase lock. The DPLL will still be trying to lock to the input clock reference, if it exists. If the Leaky Bucket Accumulator calculates that the anomaly is serious, the device disqualifies the reference source. If the device spends more than 100 seconds in Lost-phase mode, the reference is disqualified and a phase alarm is raised on it. If the reference is disqualified, one of the following transitions takes place:

1. Go to Pre-locked2;
  - If a known good stand-by source is available.
2. Go to Holdover;
  - If no stand-by sources are available.

### Holdover Mode

Holdover mode is the operating condition the device enters when its currently selected input source becomes invalid, and no other valid replacement source is available. In this mode, the device resorts to using stored frequency data, acquired when the input reference source was still valid, to control its output frequency.

In Holdover mode, the ACS8522A provides the timing and synchronization signals to maintain the Network Element but is not phase locked to any input reference source. Its output frequency is determined by an averaged version of the DPLL frequency when last in the Locked Mode.

Holdover can be configured to operate in either:

- Automatic mode  
(Reg. 34 Bit 4, *cnfg\_input\_mode*: *man\_holdover* set Low), or
- Manual mode  
(Reg. 34 Bit 4, *cnfg\_input\_mode*: *man\_holdover* set High).

### Automatic Mode

In Automatic mode, the device can be configured to operate using either:

- Averaged - (Reg. 40 Bit 7, *cnfg\_holdover\_modes*, *auto\_averaging*: set High), or
- Instantaneous - (Reg. 40 Bit 7, *cnfg\_holdover\_modes*, *auto\_averaging*: set Low).

### Averaged

In the Averaged mode, the frequency (as reported by *sts\_current\_DPLL\_frequency*, see Reg. 0C, 0D and 07) is filtered internally using an Infinite Impulse Response filter, which can be set to either:

- Fast - (Reg. 40 Bit 6, *cnfg\_holdover\_modes*, *fast\_averaging*: set High), giving a -3 dB filter response point corresponding to a period of approximately eight minutes, or
- Slow - (Reg. 40 Bit 6, *cnfg\_holdover\_modes*, *fast\_averaging*: set Low) giving a -3 dB filter response point corresponding to a period of approximately 110 minutes.

### Instantaneous

In Instantaneous mode, the DPLL freezes at the frequency it was operating at the time of entering Holdover mode. It does this by using only its internal DPLL integral path value (as reported in Reg. 0C, 0D and 07) to determine output frequency. The DPLL proportional path is not used so that any recent phase disturbances have a minimal effect on the Holdover frequency. The integral value used can be viewed as a filtered version of the locked output frequency over a short period of time. The period being in inverse proportion to the DPLL bandwidth setting.

### Manual Mode

(Reg. 34 Bit 4, *cnfg\_input\_mode*, *man\_holdover* set High.) The Holdover frequency is determined by the value in register *cnfg\_holdover\_frequency* (Reg. 3E, 3F, and part of 40). This is a 19-bit signed number, with a LSB resolution of 0.0003068 ppm, which gives an adjustment range of  $\pm 80$  ppm. This value can be derived from a reading of the register *sts\_current\_DPLL\_frequency* (Reg. 0C, 0D and 07), which gives, in the same format, an indication of the current output frequency deviation, which would be read when the device is locked. If required, this value could be read by external software and averaged over time. The averaged value could then be fed to the *cnfg\_holdover\_frequency* register, ready for setting the averaged frequency value when the device enters Holdover mode. The *sts\_current\_DPLL\_frequency* value is internally derived from the Digital Phase Locked Loop (DPLL) integral path, which represents a short-term average measure of the current frequency, depending on the locked loop bandwidth (Reg. 67) selected.

It is also possible to combine the internal averaging filters with some additional software filtering. For example the internal fast filter could be used as an anti-aliasing filter and the software could further filter this before determining the actual Holdover frequency. To support this feature, a facility to read out the internally averaged frequency has been provided.

Figure 4 Automatic Mode Control State Diagram

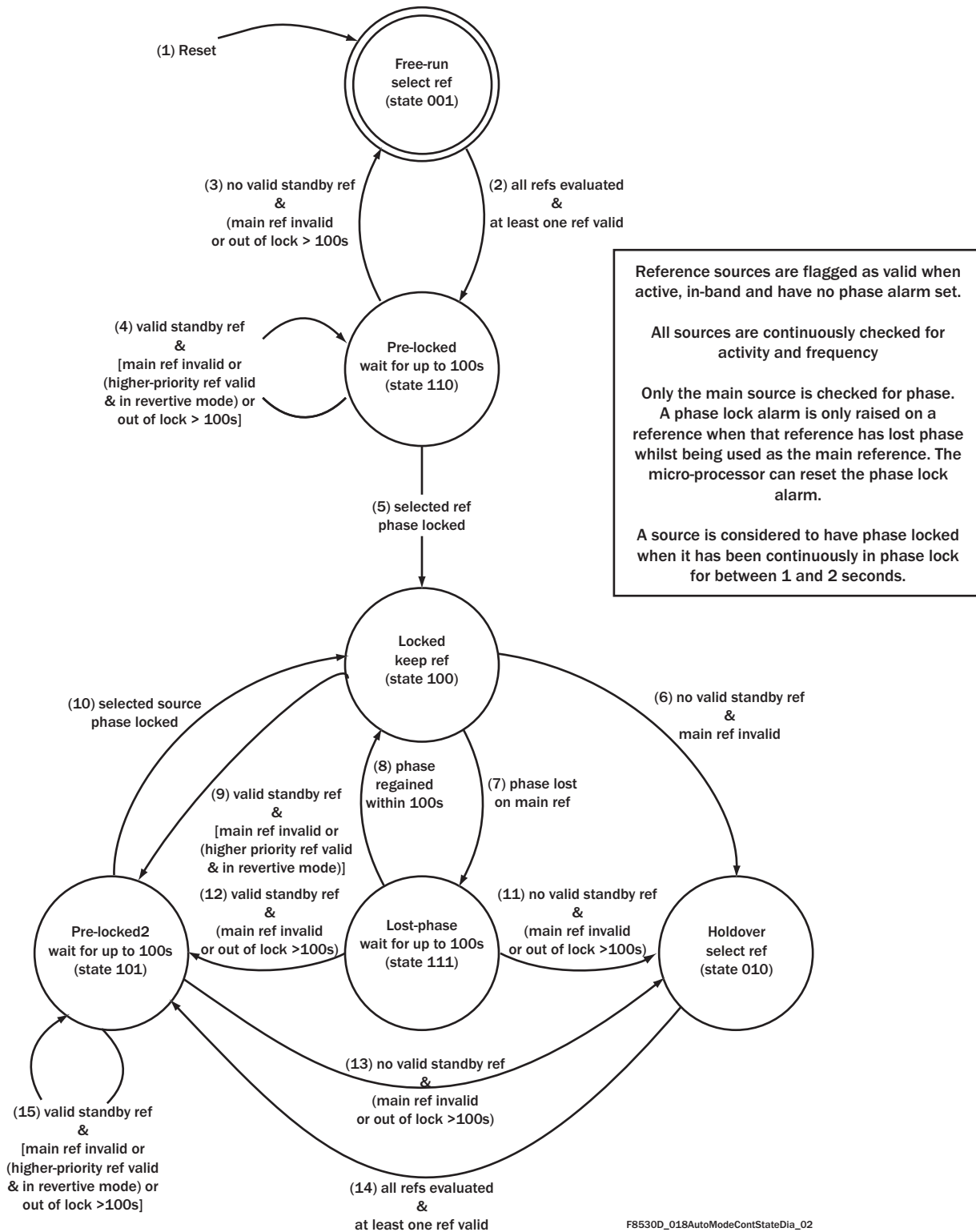



By setting Reg. 40, Bit 5, *cnfg\_holdover\_modes*, *read\_average*, the value read back from the *cnfg\_holdover\_frequency* register will be the filtered value. The filtered value is available regardless of what actual Holdover mode is selected. Clearly this results in the register not reading back the data that was written to it.

**Example: Software averaging to eliminate temperature drift.**

Select Manual Holdover mode by setting Reg. 34 Bit 4, *cnfg\_input\_mode*, *man\_holdover High*.

Select Fast Holdover Averaging mode by setting Reg. 40 Bit 6, *cnfg\_holdover\_modes*, *auto\_averaging High* and Reg. 40 Bit 7 *High*.

Select to be able to read back filtered output by setting Reg. 40 Bit 5, *cnfg\_holdover\_modes*, *read\_average High*.

Software periodically reads averaged value from the *cnfg\_holdover\_frequency* register and the temperature (not supplied from ACS8522A). Software processed frequency and temperature and places data in software look-up table or other algorithm. Software writes back appropriate averaged value into the *cnfg\_holdover\_frequency* register.

Once Holdover mode is entered, software periodically updates the *cnfg\_holdover\_frequency* register using the temperature information (not supplied from ACS8522A).

### Mini-holdover Mode

Holdover mode so far described refers to a state to which the internal state machine switches as a result of activity or frequency alarms, and this state is reported in Reg. 09. To avoid the DPLL's frequency being pulled off as a result of a failed input, then the DPLL has a fast mechanism to freeze its current frequency within one or two cycles of the input clock source stopping. Under these circumstances the DPLL enters Mini-holdover mode; the Mini-holdover frequency used being determined by Reg. 40, Bits [4:3], *cnfg\_holdover\_modes*, *mini\_holdover\_mode*.

Mini-holdover mode only lasts until one of the following happens:

- A new source has been selected, or
- The state machine enters Holdover mode, or
- The original fault on the input recovers.

### External Factors Affecting Holdover Mode

If the external TCXO/OCXO frequency is varying due to temperature fluctuations in the room, then the

instantaneous value can be different from the average value, and then it may be possible to exceed the 0.05 ppm limit (depending on how extreme the temperature fluctuations are). It is advantageous to shield the TCXO/OCXO to slow down frequency changes due to drift and external temperature fluctuations.

The frequency accuracy of Holdover mode has to meet the ITU-T, ETSI and Telcordia performance requirements. The performance of the external oscillator clock is critical in this mode, although only the frequency stability is important - the stability of the output clock in Holdover is directly related to the stability of the external oscillator.

### Pre-locked2 Mode

This state is very similar to the Pre-Locked state. It is entered from the Holdover state when a reference source has been selected and applied to the phase locked loop. It is also entered if the device is operating in Revertive mode and a higher-priority reference source is restored.

Upon applying a reference source to the phase locked loop, the ACS8522A will enter the Locked state in a maximum of 100 seconds, as defined by GR-1244-CORE<sup>[19]</sup> specification, if the selected reference source is of good quality.

If the device cannot achieve lock within 100 seconds, it reverts to Holdover mode and another reference source is selected.

### DPLL Architecture and Configuration

A Digital PLL gives a stable and consistent level of performance that can be easily programmed for different dynamic behavior or operating range. It is not affected by operating conditions or silicon process variations. Digital synthesis is used to generate all required SONET/SDH output frequencies. The digital logic operates at 204.8 MHz that is multiplied up from the external 12.800 MHz oscillator module. Hence the best resolution of the output signals from the DPLL is one 204.8 MHz cycle or 4.9 ns.

Additional resolution and lower final output jitter is provided by a de-jittering Analog PLL that reduces the 4.9 ns pk-pk jitter from the digital down to 500 ps pk-pk and 60 ps RMS as typical final outputs measured broadband (from 10 Hz to 1 GHz).

This arrangement combines the advantages of the flexibility and repeatability of a DPLL with the low jitter of an APLL. The DPLLs in the ACS8522A are uniquely very

programmable for all PLL parameters of bandwidth (from 0.1 Hz up to 70 Hz), damping factor (from 1.2 to 20), frequency acceptance and output range (from 0 to 80 ppm, typically 9.2 ppm), input frequency (12 common SONET/SDH spot frequencies) and input-to-output phase offset (in 6 ps steps up to 200 ns). There is no requirement to understand the loop filter equations or detailed gain parameters since all high level factors such as overall bandwidth can be set directly via registers in the microprocessor interface. No external critical components are required for either the internal DPLLs or APLLs, providing another key advantage over traditional discrete designs.

The T4 DPLL is similar in structure to the T0 DPLL, but since the T4 is only providing a clock synthesis and input to output frequency translation function, with no defined requirement for jitter attenuation or input phase jump absorption, then its bandwidth is limited to the high end and the T4 does not incorporate many of the Phase Build-out and adjustment facilities of the T0 DPLL.

### T0 DPLL Main Features

- Two programmable DPLL bandwidth controls (Locked and Acquisition bandwidth), each with 10 steps from 0.1 Hz to 70 Hz
- Programmable damping factor: For optional faster locking and peaking control. Factors = 1.2, 2.5, 5, 10 or 20
- Multiple phase lock detectors
- Input to output phase offset adjustment (Master/Slave),  $\pm 200$  ns, 6 ps resolution step size
- PBO phase offset on source switching - disturbance down to  $\pm 5$  ns
- Multi-cycle phase detection and locking, programmable up to  $\pm 8192$  UI - improves jitter tolerance in direct lock mode
- Holdover frequency averaging with a choice of: Average times: 8 minutes or 110 minutes. Value can also be read out.
- Multiple E1 and DS1 outputs supported
- Low jitter MFrSync (2 kHz) and FrSync (8 kHz) outputs.

### T4 DPLL Main Features

- Single programmable DPLL bandwidth control: 18 Hz, 35 Hz or 70 Hz
- Programmable damping factor: For optional faster locking and peaking control. Factors = 1.2, 2.5, 5, 10 or 20
- Multiple phase lock detectors
- Multi-cycle phase detection and locking, programmable up to  $\pm 8192$  UI - improves jitter tolerance in direct lock mode
- DS3/E3 support (44.736 MHz / 34.368 MHz) at same time as OC-N rates from T0 DPLL
- Low jitter E1/DS1 options at same time as OC-N rates from T0 DPLL
- Frequencies of  $n \times E1/DS1$  including 16 and 12 x E1, and 16 and 24 x DS1 supported
- Low jitter MFrSync (2 kHz) and FrSync (8 kHz) outputs
- Can use the T4 DPLL as an Independent FrSync DPLL
- Can use the phase detector in T4 DPLL to measure the input phase difference between two inputs.

The structure of the T0 and T4 PLLs are shown later in Figure 10 in the section on output clock ports. That section also details how the DPLLs and particular output frequencies are configured. The following sections detail some component parts of the DPLL.

### T0 DPLL Automatic Bandwidth Controls

In Automatic Bandwidth Selection mode (Reg. 3B), the T0 DPLL bandwidth setting is selected automatically from the Acquisition Bandwidth or Locked Bandwidth configurations programmed in *cnfg\_TO\_DPLL\_acq\_bw* Reg. 69 and *cnfg\_TO\_DPLL\_locked\_bw* Reg. 67 respectively. If this mode is not selected, the DPLL acquires and locks using only the bandwidth set by Reg. 67.

### Phase Detectors

A Phase and Frequency detector is used to compare input and feedback clocks. This operates at input frequencies up to 77.76 MHz. The whole DPLL can operate at spot frequencies from 2 kHz up to 77.76 MHz. A common arrangement however is to use Lock8k mode (see Bit 6 of Reg. 22, 23, 27 and 28) where all input frequencies are divided down to 8 kHz internally. Marginally better MTIE figures may be possible in direct lock mode due to more regular phase updates.

A patented multi-phase detector is used in order to give an infinitesimally small input phase resolution combined with large jitter tolerance. The following phase detectors are used:

- Phase and frequency detector ( $\pm 360^\circ$  or  $\pm 180^\circ$  range)
- An early/late phase detector for fine resolution
- A multi-cycle phase detector for large input jitter tolerance (up to 8191 UI), which captures and remembers phase differences of many cycles between input and feedback clocks.

The phase detectors can be configured to be immune to occasional missing input clock pulses by using nearest edge detection ( $\pm 180^\circ$  capture) or the normal  $\pm 360^\circ$  phase capture range which gives frequency locking. The device will automatically switch to nearest edge locking when the multi-UI phase detector is not enabled and the other phase detectors have detected that phase lock has been achieved.

It is possible to disable the selection of nearest edge locking via Reg. 03 Bit 6 set to 1. In this setting, frequency locking will always be enabled.

The balance between the first two types of phase detector employed can be adjusted via registers 6A to 6D. The default settings should be sufficient for all modes. Adjustment of these settings affects only small signal overshoot and bandwidth.

The multi-cycle phase detector is enabled via Reg. 74, Bit 6 set to 1 and the range is set in exponentially increasing steps from  $\pm 1$  UI, 3 UI, 7 UI, 15 UI ... up to 8191 UI via Reg. 74, Bits [3:0].

When this detector is enabled it keeps a track of the correct phase position over many cycles of phase difference to give excellent jitter tolerance. This provides an alternative to switching to Lock8k mode as a method of achieving high jitter tolerance.

An additional control (Reg. 74 Bit 5) enables the multi-phase detector value to be used in the final phase value as part of the DPLL loop. When enabled by setting *High*, the multi cycle phase value will be used in the loop and gives faster pull in (but more overshoot). The characteristics of the loop will be similar to Lock8k mode where again large input phase differences contribute to the loop dynamics. Setting the bit *Low* only uses a max figure of 360 degrees in the loop and will give slower pull-in but gives less overshoot. The final phase position that

the loop has to pull in to is still tracked and remembered by the multi-cycle phase detector in either case.

### Phase Lock/Loss Detection

Phase lock/loss detection is handled in several ways. Phase loss can be triggered from:

- The fine phase lock detector, which measures the phase between input and feedback clock
- The coarse phase lock detector, which monitors whole cycle slips
- Detection that the DPLL is at min. or max. frequency
- Detection of no activity on the input.

Each of these sources of phase loss indication is individually enabled via register bits (see Reg. 73, 74 and 4D). Phase lock or lost is used to determine whether to switch to nearest edge locking and whether to use acquisition or Locked bandwidth settings for the DPLL. Acquisition bandwidth is used for faster pull-in from an unlocked state.

The coarse phase lock detector detects phase differences of  $n$  cycles between input and feedback clocks, where  $n$  is set by Reg. 74, Bits 3:0; the same register that is used for the coarse phase detector range, since these functions go hand in hand. This detector may be used in the case where it is required that a phase loss indication is not given for reasonable amounts of input jitter and so the fine phase loss detector is disabled and the coarse detector is used instead.

### Damping Factor Programmability

The DPLL damping factor is set by default to provide a maximum wander gain peak of around 0.1 dB. Many of the specifications (e.g. GR-1244-CORE<sup>[19]</sup>, G.812<sup>[10]</sup> and G.813<sup>[11]</sup>) specify a wander transfer gain of less than 0.2 dB. GR-253<sup>[17]</sup> specifies jitter (not wander) transfer of less than 0.1 dB. To accommodate the required levels of transfer gain, the ACS8522A provides a choice of damping factors, with more choice given as the bandwidth setting increases into the frequency regions classified as jitter. Table 5 shows which damping factors are available for selection at the different bandwidth settings, and what the corresponding jitter transfer approximate gain peak will be.

**Table 5 Available Damping Factors for different DPLL Bandwidths, and associated Jitter Peak Values**

Bandwidth	Reg. 6B [2:0]	Damping Factor selected	Gain Peak/ dB
0.1 Hz to 4 Hz	1, 2, 3, 4, 5	5	0.1
8 Hz	1	2.5	0.2
	2, 3, 4, 5	5	0.1
18 Hz	1	1.2	0.4
	2	2.5	0.2
	3, 4, 5	5	0.1
35 Hz	1	1.2	0.4
	2	2.5	0.2
	3	5	0.1
	4, 5	10	0.06
70 Hz	1	1.2	0.4
	2	2.5	0.2
	3	5	0.1
	4	10	0.06
	5	20	0.03

### Local Oscillator Clock

The Master system clock on the ACS8522A should be provided by an external clock oscillator of frequency 12.800 MHz. The clock specification is important for meeting the ITU/ETSI and Telcordia performance requirements for Holdover mode. ITU and ETSI specifications permit a combined drift characteristic, at constant temperature, of all non-temperature-related parameters, of up to 10 ppb per day. The same specifications allow a drift of 1 ppm over a temperature range of 0 to +70 °C.

**Table 6 ITU and ETSI Specification**

Parameter	Value
Tolerance	±4.6 ppm over 20 year lifetime
Drift (Frequency Drift over supply voltage range of +2.7 V to +3.3 V)	±0.05 ppm/15 seconds @ constant temp.
	±0.01 ppm/day @ constant temp.
	±1 ppm over temp. range 0 to +70 °C

Telcordia specifications are somewhat tighter, requiring a non-temperature-related drift of less than 40 ppb per day

**Table 7 Telcordia GR-1244 CORE Specification**

Parameter	Value
Tolerance	±4.6 ppm over 20 year lifetime
Drift (Frequency Drift over supply voltage range of +2.7 V to +3.3 V)	±0.05 ppm/15 seconds @ constant temp.
	±0.04 ppm/15 seconds @ constant temp.
	±0.28 ppm/over temp. range 0 to +50 °C

and a drift of 280 ppb over the temperature range 0 to +50 °C. Please contact Semtech for information on crystal oscillator suppliers

### Crystal Frequency Calibration

The absolute crystal frequency accuracy is less important than the stability since any frequency offset can be compensated by adjustment of register values in the IC. This allows for calibration and compensation of any crystal frequency variation away from its nominal value. ± 50 ppm adjustment would be sufficient to cope with most crystals, in fact the range is an order of magnitude larger due to the use of two 8-bit register locations. The setting of the *cnfg\_nominal\_frequency* register allows for this adjustment. An increase in the register value increases the output frequencies by 0.0196229 ppm for each LSB step.

*Note... The default register value (in decimal) = 39321 (9999 hex) = 0 ppm offset. The minimum to maximum offset range of the register is 0 to 65535 dec, giving an adjustment range of -771 ppm to +514 ppm of the output frequencies, in 0.0196229 ppm steps.*

*Example: If the crystal was oscillating at 12.800 MHz + 5 ppm, then the calibration value in the register to give a - 5 ppm adjustment in output frequencies to compensate for the crystal inaccuracy, would be:  
39321 - (5 / 0.0196229) = 39066 (dec) = 989A (hex).*

### Output Wander

Wander and jitter present on the output clocks are dependent on:

- The magnitudes of wander and jitter on the selected input reference clock (in Locked mode)
- The internal wander and jitter transfer characteristic (in Locked mode)
- The jitter on the local oscillator clock
- The wander on the local oscillator clock (in Holdover mode).

Wander and jitter are treated in different ways to reflect their differing impacts on network design. Jitter is always

strongly attenuated, whilst wander attenuation can be varied to suit the application and operating state. Wander and jitter attenuation is performed using a digital phase locked loop (DPLL) with a programmable bandwidth. This gives a transfer characteristic of a low pass filter, with a programmable pole. It is sometimes necessary to change the filter dynamics to suit particular circumstances - one example being when locking to a new source, the filter can be opened up to reduce locking time and can then be tightened again to remove wander. A change between different bandwidths for locking and for acquisition is handled automatically within the ACS8522A.

There may be a phase shift across the ACS8522A between the selected input reference source and the output clock over time, mainly caused by frequency wander in the external oscillator module. Higher stability XOs will give better performance for MTIE. The oscillator becomes more critical at DPLL bandwidth near to or below 0.1 Hz since the rate of change of the DPLL may be slow compared to the rate of change of the oscillator frequency. Shielding of the OCXO or TCXO can further slow down the rate of change of temperature and hence frequency, thus improving output wander performance.

The phase shift may vary over time but will be constrained to lie within specified limits. The phase shift is characterized using two parameters, MTIE (Maximum Time Interval Error) and TDEV (Time Deviation) which, although being specified in all relevant specifications, differ in acceptable limits in each one.

Typical measurements for the ACS8522A are shown in Figure 5, for Locked mode operation. Figure 6 shows a typical measurement of Phase Error accumulation in Holdover mode operation.

The required performance for phase variation during Holdover is specified in several ways and depends on the

relevant specification (See "References" on page 115), for example:

1. ETSI ETS-300 462-5<sup>[4]</sup>, Section 9.1, requires that the short-term phase error during switchover (i.e. Locked to Holdover to Locked) be limited to an accumulation rate no greater than 0.05 ppm during a 15 second interval.
2. ETSI ETS-300 462-5<sup>[4]</sup>, Section 9.2, requires that the long-term phase error in the Holdover mode should not exceed:  

$$\{(a1 + a2)S + 0.5bS^2 + c\}$$
 where  
 $a1 = 50 \text{ ns/s}$  (allowance for initial frequency offset)  
 $a2 = 2000 \text{ ns/s}$  (allowance for temperature variation)  
 $b = 1.16 \times 10^{-4} \text{ ns/s}^2$  (allowance for ageing)  
 $c = 120 \text{ ns}$  (allowance for entry into Holdover mode).  
 $S =$  Elapsed time (s) after loss of external ref. input
3. ANSI Tin1.101-1999<sup>[1]</sup>, Section 8.2.2, requires that the phase variation be limited so that no more than 255 slips (of 125  $\mu\text{s}$  each) occur during the first day of Holdover. This requires a frequency accuracy better than:  

$$\frac{((24 \times 60 \times 60) + (255 \times 125 \mu\text{s}))}{(24 \times 60 \times 60)} = 0.37 \text{ ppm}$$
 Temperature variation is not restricted, except to within the normal bounds of 0 to 50 °C.
4. Telcordia GR-1244-CORE<sup>[19]</sup>, Section 5.2, shows that an initial frequency offset of 50 ppb is permitted on entering Holdover, whilst a drift over temperature of 280 ppb is allowed; an allowance of 40 ppb is permitted for all other effects.
5. ITU G.822<sup>[12]</sup>, Section 2.6, requires that the slip rate during category (b) operation (interpreted as being applicable to Holdover mode operation) be limited to less than 30 slips (of 125  $\mu\text{s}$  each) per hour.  

$$\frac{((60 \times 60) + (30 \times 125 \mu\text{s}))}{(60 \times 60)} = 1.042 \text{ ppm}$$

Figure 5 Maximum Time Interval Error and Time Deviation of T0 PLL Output Port

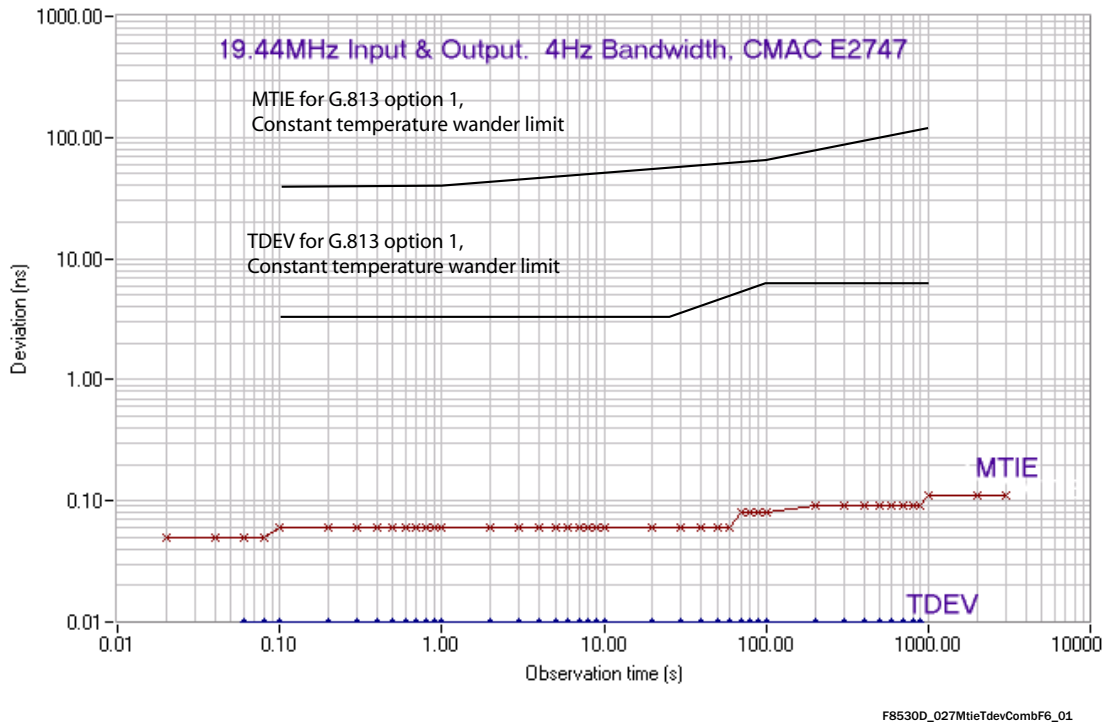
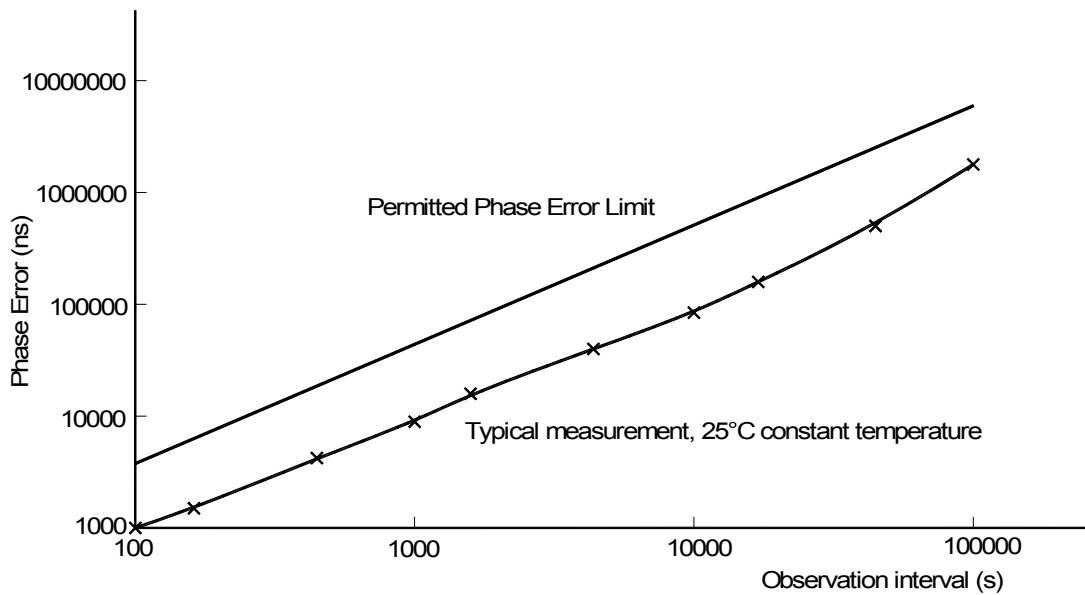

Figure 6 Phase Error Accumulation of T0 PLL Output Port in Holdover Mode



### Jitter and Wander Transfer

The ACS8522A has a programmable jitter and wander transfer characteristic. This is set by the DPLL bandwidth. The -3 dB jitter transfer attenuation point can be set in the range from 0.1 Hz to 70 Hz in 10 steps. The wander and jitter transfer characteristic is shown in Figure 7. Wander on the local oscillator clock will not have a significant effect on the output clock whilst in Locked mode, provided that the DPLL bandwidth is set high enough so that the DPLL can compensate quickly enough for any frequency changes in the crystal.

In Free-run or Holdover mode wander on the crystal is more significant. Variation in crystal temperature or supply voltage both cause drifts in operating frequency, as does ageing. These effects must be limited by careful selection of a suitable component for the local oscillator, as specified in the section See Local Oscillator Clock.

### Phase Build-out

Phase Build-out (PBO) is the function to minimize phase transients on the output SEC clock during input reference switching. If the currently selected input reference clock source is lost (due to a short interruption, out of frequency detection, or complete loss of reference) the second, next highest priority reference source will be selected, and a PBO event triggered.

ITU-T G.813<sup>[11]</sup> states that the maximum allowable short-term phase transient response, resulting from a switch from one clock source to another, with Holdover mode entered in between, should be a maximum of 1  $\mu$ s over a 15 second interval. The maximum phase transient or jump should be less than 120 ns at a rate of change of less than 7.5 ppm and the Holdover performance should be better than 0.05 ppm. The ACS8522A performance is well within this requirement. The typical phase disturbance on clock reference source switching will be less than 5 ns on the ACS8522A.

When a PBO event is triggered, the device enters a temporary Holdover state. When in this temporary state, the phase of the input reference is measured, relative to the output. The device then automatically accounts for any measured phase difference and adds the appropriate phase offset into the DPLL to compensate. Following a PBO event, whatever the phase difference on change of input, the output phase transient is minimized to be no greater than 5 ns.

On the ACS8522A, PBO can be enabled, disabled or frozen using the serial interface. By default, it is enabled. When PBO is enabled, PBO can also be frozen (at the current offset setting). The device will then ignore any further PBO events occurring on any subsequent reference switch, and maintain the current phase offset. If PBO is disabled

**Figure 7 Sample of Wander and Jitter Measured Transfer Characteristics**

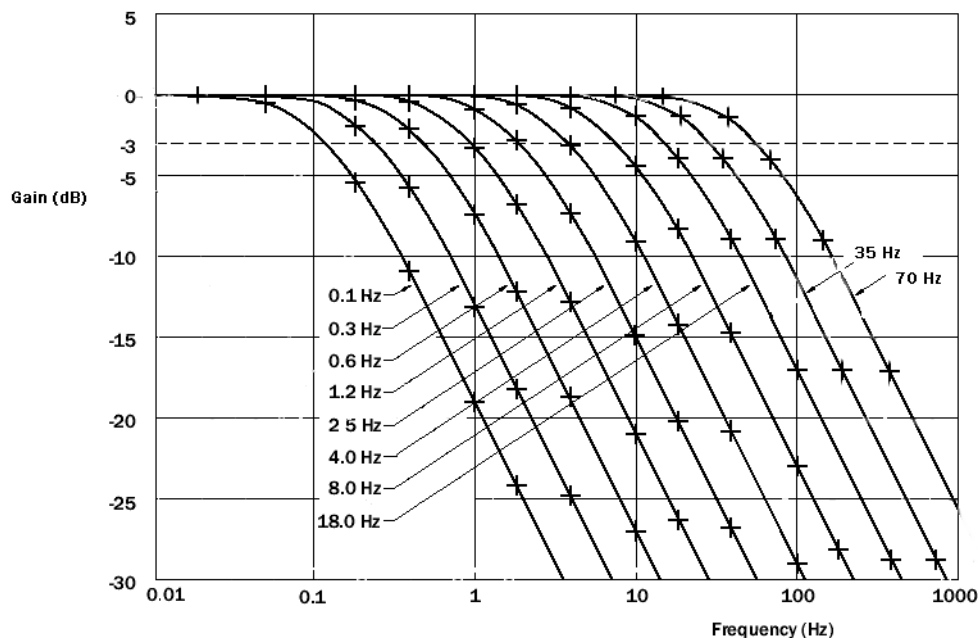

while the device is in the Locked mode, there may be a phase shift on the output SEC clocks as the DPLL locks back to 0 degrees phase error. The rate of phase shift will depend on the programmed bandwidth. Enabling PBO whilst in the Locked state will also trigger a PBO event.

#### PBO Phase Offset

In order to minimize the systematic (average) phase error for PBO, a PBO Phase Offset can be programmed in 0.101 ns steps in the *cnfg\_PBO\_phase\_offset* register, Reg. 72. The range of the programmable PBO phase offset is restricted to  $\pm 1.4$  ns. This can be used to eliminate an accumulation of phase shifts in one direction.

#### Input-to-Output Phase Adjustment

When PBO is off (including Auto-PBO on phase transients), such that the system always tries to align the outputs to the inputs at the 0° position, there is a mechanism provided in the ACS8522A for precise fine tuning of the output phase position with respect to the input. This can be used to compensate for circuit and board wiring delays. The output phase can be adjusted in 6 ps steps up to 200 ns in a positive or negative direction. The phase adjustment actually changes the phase position of the feedback clock so that the DPLL adjusts the output clock phases to compensate. The rate of change of phase is therefore related to the DPLL bandwidth. For the DPLL to track large instant changes in phase, either Lock8k mode should be on, or the coarse phase detector should be enabled. Register *cnfg\_phase\_offset* at Reg. 70 and 71 controls the output phase, which is only used when PBO is off (Reg. 48, Bit 2 = 0 and Reg. 76, Bit 4 = 0).

#### Input Wander and Jitter Tolerance

The ACS8522A is compliant to the requirements of all relevant standards, principally ITU Recommendation G.825<sup>[15]</sup>, ANSI DS1.101-1999<sup>[1]</sup>, Telcordia GR1244<sup>[19]</sup>, GR253<sup>[17]</sup>, G812<sup>[10]</sup>, G813<sup>[11]</sup> and ETS 300 462-5 (1996)<sup>[4]</sup>.

All reference clock inputs have a tight frequency tolerance but a generous jitter tolerance. Pull-in, hold-in and pull-out ranges are specified in Table 8. Minimum jitter tolerance masks are specified in Figures 8 and 9, and Tables 8 and 10, respectively. The ACS8522A will tolerate wander and jitter components greater than those shown in Figure 8 and Figure 9, up to a limit determined by a combination of the apparent long-term frequency offset caused by wander and the eye-closure caused by jitter (the input source will be rejected if the offset pushes the frequency outside the hold-in range for long enough to be detected, whilst the signal will also be rejected if the eye closes sufficiently to affect the signal purity). Either the Lock8k mode, or one of the extended phase capture ranges should be engaged for high jitter tolerance according to these masks.

All reference clock ports are monitored for quality, including frequency offset and general activity. Single short-term interruptions in selected reference clocks may not cause re-arrangements, whilst longer interruptions, or multiple, short-term interruptions, will cause re-arrangements, as will frequency offsets which are sufficiently large or sufficiently long to cause loss-of-lock in the phase-locked loop. The failed reference source will be removed from the priority table and declared as unserviceable, until its perceived quality has been restored to an acceptable level.

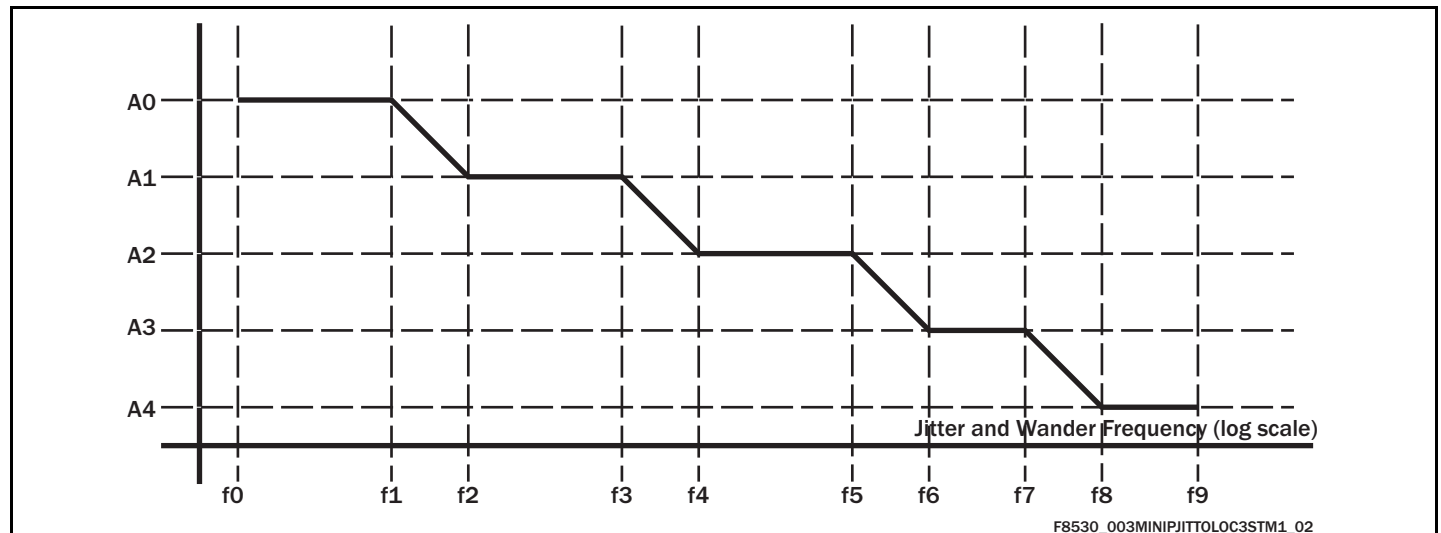

**Table 8 Input Reference Source Jitter Tolerance**

Jitter Tolerance	Frequency Monitor Acceptance Range	Frequency Acceptance Range (Pull-in)	Frequency Acceptance Range (Hold-in)	Frequency Acceptance Range (Pull-out)
G.703 <sup>[6]</sup>	±16.6 ppm	±4.6 ppm (see Note (i)) ±9.2 ppm (see Note (ii))	±4.6 ppm (see Note (i)) ±9.2 ppm (see Note (ii))	±4.6 ppm (see Note (i)) ±9.2 ppm (see Note (ii))
G.783 <sup>[9]</sup>				
G.823 <sup>[13]</sup>				
GR-1244-CORE <sup>[19]</sup>				

- Notes: (i) The frequency acceptance and generation range will be ±4.6 ppm around the required frequency when the external crystal frequency accuracy is within a tolerance of ±4.6 ppm.  
(ii) The fundamental acceptance range and generation range is ±9.2 ppm with an exact external crystal frequency of 12.800 MHz. This is the default DPLL range, the range is also programmable from 0 to 80 ppm in 0.08 ppm steps.

**Figure 8 Minimum Input Jitter Tolerance (OC-3/STM-1)**



Note...For inputs supporting G.783<sup>[9]</sup> compliant sources.)

**Table 9 Amplitude and Frequency Values for Jitter Tolerance (OC-3/STM-1)**

STM level	Peak to peak amplitude (unit Interval)					Frequency (Hz)									
	A0	A1	A2	A3	A4	F0	F1	F2	F3	F4	F5	F6	F7	F8	F9
STM-1	2800	311	39	1.5	0.15	12 u	178 u	1.6 m	15.6 m	0.125	19.3	500	6.5 k	65 k	1.3

Figure 9 Minimum Input Jitter Tolerance (DS1/E1)

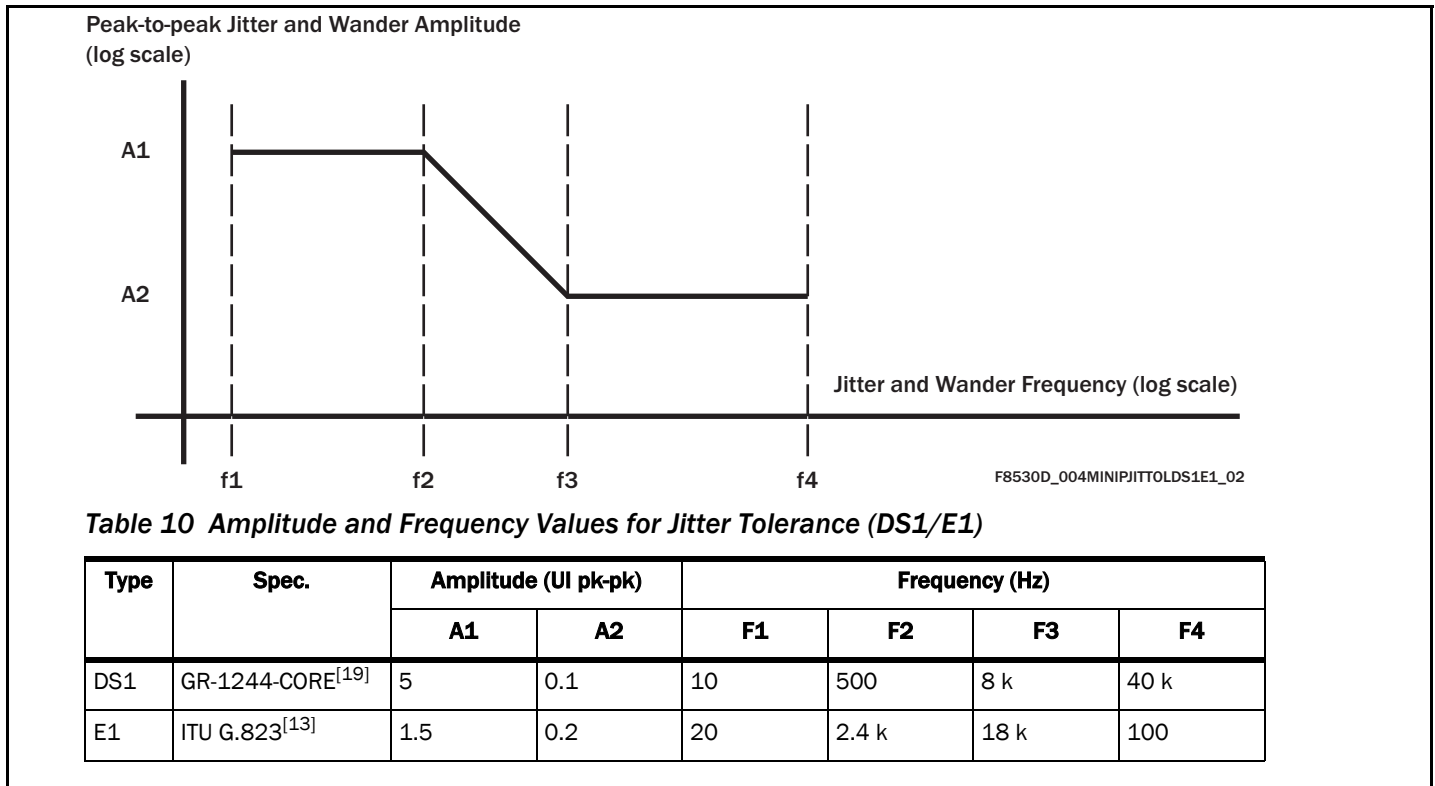

**Using the DPLLs for Accurate Frequency and Phase Reporting**

The frequency monitors in the ACS8522A perform frequency monitoring with a programmable acceptable limit of up to ±60.96 ppm. The resolution of the measurement is 3.8 ppm and the measured frequency can be read back from Reg. 4C, with channel selection at Reg. 4B. For more accurate measurement of both frequency and phase, the T0 and T4 DPLLs and their phase detectors, can be used to monitor both input frequency and phase. The T0 DPLL is always monitoring the currently locked to source, but if the T4 path is not used then the T4 DPLL can be used as a roving phase and frequency meter. Via software control it could be switched to monitor each input in turn and both the phase and frequency can be reported with a very fine resolution.

The registers *sts\_current\_DPLL\_frequency* (Reg. 0C, 0D and 07) report the frequency of either the T0 or T4 DPLL with respect to the external crystal XO frequency (after calibration via Reg. 3C, Reg. 3D if used). The selection of T4 or T0 DPLL reporting is made via Reg. 4B, Bit 4. The value is a 19-bit signed number with one LSB representing 0.0003068 ppm (range of ±80 ppm). This value is actually the integral path value in the DPLL, and as such corresponds to an averaged measurement of the

input frequency, with an averaging time inversely proportional to the DPLL bandwidth setting. Reading this regularly can show how the currently locked source is varying in value e.g. due to frequency wander on its input.

The input phase, as seen at the DPLL phase detector, can be read back from register *sts\_current\_phase*, Reg. 77 and 78. T0 or T4 DPLL phase detector reporting is again controlled by Reg. 4B, Bit 4. One LSB corresponds to approximately 0.7 degrees phase difference. For the T0 DPLL this will be reporting the phase difference between the input and the internal feedback clock. The phase result is internally averaged or filtered with a -3 dB attenuation point at approximately 100 Hz. For low DPLL bandwidths, 0.1 Hz for example, this measured phase information from the T0 DPLL gives input phase wander in the frequency band from for example 0.1 Hz to 100 Hz. This could be used to give a crude input MTIE measurement up to an observation period of approximately 1000 seconds using external software.

In addition, the T4 DPLL phase detector can be used to make a phase measurement between two inputs. Reg. 65, Bit 7 is used to switch one input to the T4 phase detector over to the current T0 input. The other phase detector input remains connected to the selected T4 input source, the selected source can be forced via Reg. 35,

Bits 3:0, or changed via the T4 priority (Reg. 19 to 1C, when Reg. 4B, Bit 4 = 1).

Consequently the phase detector from the T4 DPLL could be used to measure the phase difference between the currently selected source and the stand-by source, or it could be used to measure the phase wander of all stand-by sources with respect to the current source by selecting each input in sequence. An MTIE and TDEV calculation could be made for each input via external processing.

### MFrSync and FrSync Alignment-SYNC2K

The SYNC2K input will normally be a 2 kHz frequency and only its falling edge is used. It can however be at a frequencies of 4 kHz or 8 kHz without any change to the register setups. Only alignment of the 8 kHz will be achieved in this case.

Safe sampling of the SYNC2K input is achieved by using the currently selected clock reference source to do the input sampling. This is based on the principle that FrSync alignment is being used on a Slave device that is locked to the clock reference of a Master device that is also providing the 2 kHz SYNC2K input. Phase Build-out mode should be off (Reg. 48, Bit 2 = 0). The 2 kHz MFrSync output from the Master device has its falling edge aligned with the falling edge of the other output clocks, hence the SYNC2K input is normally sampled on the rising edge of the current input reference clock, in order to provide the most margin. Some modification of the expected timing of the SYNC2K with respect to the reference clock can be achieved via Reg. 7B, Bits [1:0]. This allows for the SYNC2K input to arrive either half a reference clock cycle early or up to one and a half cycle late, hence allowing a safe sampling margin to be maintained.

A different sampling resolution is used depending on the input reference frequency and the setting of Reg. 7B, *cnfg\_sync\_phase*, Bit 6 *indep\_FrSync/MFrSync*. With this bit *Low*, the SYNC2K input sampling has a 6.48 MHz resolution, this being the preferred reference frequency to lock to from the Master, in conjunction with the SYNC2K 2 kHz, since it gives the most timing margin on the sampling and aligns all of the higher rate OC-3 derived clocks. When Bit 6 is *High* the SYNC2K can have a sampling resolution of either 19.44 MHz (when the current locked to reference is 19.44 MHz) or 38.88 MHz (all other frequencies). This would allow for instance a 19.44 MHz and 2 kHz pair to be used for Slave synchronization or for Line card synchronization. Reg. 7B Bit 7, *indep\_FrSync/MFrSync* controls whether the 2 kHz

MFrSync and 8 kHz FrSync outputs keep their precise alignment with the other output clocks.

When *indep\_FrSync/MFrSync* Reg. 7B Bit 7 is *Low* the FrSyncs and the other higher rate clocks are not independent and their alignment on the falling 8kHz edge is maintained. This means that when Bit *Sync\_OC-N\_rates* is *High*, the OC-N rate dividers and clocks are also synchronized by the SYNC2K input. On a change of phase position of the SYNC2K, this could result in a shift in phase of the 6.48 MHz output clock when a 19.44 MHz precision is used for the SYNC2K input. To avoid disturbing any of the output clocks and only align the MFrSync and FrSync outputs, at the chosen level of precision, then independent Frame Sync mode can be used (Reg. 7B, bit 7 = 1). Edge alignment of the FrSync output with other clocks outputs may then change depending on the SYNC2K sampling precision used. For example with a 19.44 MHz reference input clock and Reg. 7B, bits 6 & 7 both *High* (independent mode and Sync OC-N rates), then the FrSync output will still align with the 19.44 MHz output but not with the 6.48 MHz output clock.

The FrSync and MFrSync outputs always come from the T0 DPLL path. 2kHz and 8kHz outputs can also be produced at the O1 to O4 outputs. These can come from either the T0 DPLL or from the T4 DPLL, controlled by Reg. 7A, bit 7.

If required, this allows the T4 DPLL to be used as a separate PLL for the FrSync and MFrSync path with a 2 kHz input and 2 kHz and 8 kHz Frame Sync outputs.

### Output Clock Ports

The device supports a set of main output clocks, O1 to O4 and a pair of secondary Sync outputs, FrSync and MFrSync. The four main output clocks are independent of each other and are individually selectable. The two secondary output clocks, FrSync and MFrSync, are derived from the T0 path only. The frequencies of the main output clocks are selectable from a range of pre-defined spot frequencies, as defined in Table 11. Output technologies are TTL/CMOS for all outputs except O1 which can be PECL or LVDS.

### PECL/LVDS Output Port Selection

The choice of PECL or LVDS compatibility for Output O1 is programmed via the *cnfg\_differential\_outputs* register, Reg. 3A.

## Output Frequency Selection and Configuration

The output frequency of outputs O1 to O4 is controlled by a number of interdependent parameters. These parameters control the selections within the various blocks shown in Figure 10.

The ACS8522A contains two main DPLL/APLL paths, T0 and T4. Whilst they are largely independent, there are a number of ways in which these two structures can interact. Figure 10 is an expansion of the top level Block Diagram (Figure 1) showing the PLL paths in more detail.

### T0 DPLL and APLLs

The T0 DPLL always produces 77.76 MHz regardless of either the reference frequency (frequency at the input pin of the device) or the locking frequency (frequency at the input of the DPLL Phase and Frequency Detector (PFD)).

The input reference is either passed directly to the PFD or via a pre-divider (not shown) to produce the reference input. The feedback 77.76 MHz is either divided or synthesized to generate the locking frequency.

Digital Frequency Synthesis (DFS) is a technique for generating an output frequency using a higher frequency system clock (204.8 MHz in the case of the 77.76 MHz synthesis). However, the edges of the output clock are not ideally placed in time, since all edges of the output clock will be aligned to the active edge of the system clock. This will mean that the generated clock will inherently have jitter on it equivalent to one period of the system clock.

The T0 77M forward DFS block uses DFS clocked by the 204.8 MHz system clock to synthesize the 77.76 MHz and, therefore, has an inherent 4.9 ns of pk-pk jitter. There is an option to use an APLL, the T0 feedback APLL, to filter out this jitter before the 77.76 MHz is used to generate the feedback locking frequency in the T0 feedback DFS block. This analog feedback option allows a lower jitter (<1 ns) feedback signal to give maximum performance. The digital feedback option is present so that when the output path is switched to digital feedback the two paths remain synchronized.

The T0 77M forward DFS block is also the block that handles Phase Build-out and any phase offset programmed into the device. Hence, the T0 77M forward

DFS and the T0 77M output DFS blocks are locked in frequency but may be offset in phase.

The T0 77M output DFS block also uses the 204.8 MHz system clock and always generates 77.76 MHz for the output clocks (with inherent 4.9 ns of jitter). This is fed to another DFS block and to the T0 output APLL. The low frequency T0 LF output DFS block is used to produce three frequencies; two of them, Digital1 and Digital2, are available for selection to be produced at outputs O1 to O4, and the third frequency can produce multiple E1/DS1 rates via the filtering APLLs. The input clock to the T0 LF output DFS block is either 77.76 MHz from the T0 output APLL (post jitter filtering) or 77.76 MHz direct from the T0 77M output DFS. Utilizing the clock from the T0 output APLL will result in lower jitter outputs from the T0 LF output DFS block. However, when the input to the T0 APLL is taken from the T0 LF output DFS block, the input to that block comes directly from the T0 77M output DFS block so that a “loop” is not created.

The T0 output APLL is for multiplying and filtering. The input to the T0 output APLL can be either 77.76 MHz from the T0 77M output DFS block or an alternative frequency from the T0 LF output DFS block (offering 77.76 MHz, 12E1, 16E1, 24DS1 or 16DS1). The frequency from the T0 output APLL is four times its input frequency i.e. 311.04 MHz when used with a 77.76 MHz input. The T0 output APLL is subsequently divided by 1, 2, 4, 6, 8, 12, 16 and 48 and these are available at the O1 to O4 outputs.

### T4 DPLL & APLL

The T4 path is much simpler than the T0 path. This path offers no Phase Build-out or phase offset. The T4 input can be used to either lock to a reference clock input independent of the T0 path, or lock to the T0 path. Unlike the T0 path, the T4 forward DFS block does not always generate 77.76 MHz. The possible frequencies are listed in the table. Similar to the T0 path, the output of the T4 forward DFS block is generated using DFS clocked by the 204.8 MHz system clock and will have an inherent jitter of 4.9 ns.

The T4 feedback DFS also has the facility to be able to use the post T4 APLL (jitter-filtered) clock to generate the feedback locking frequency. Again, this will give the maximum performance by using a low jitter feedback.

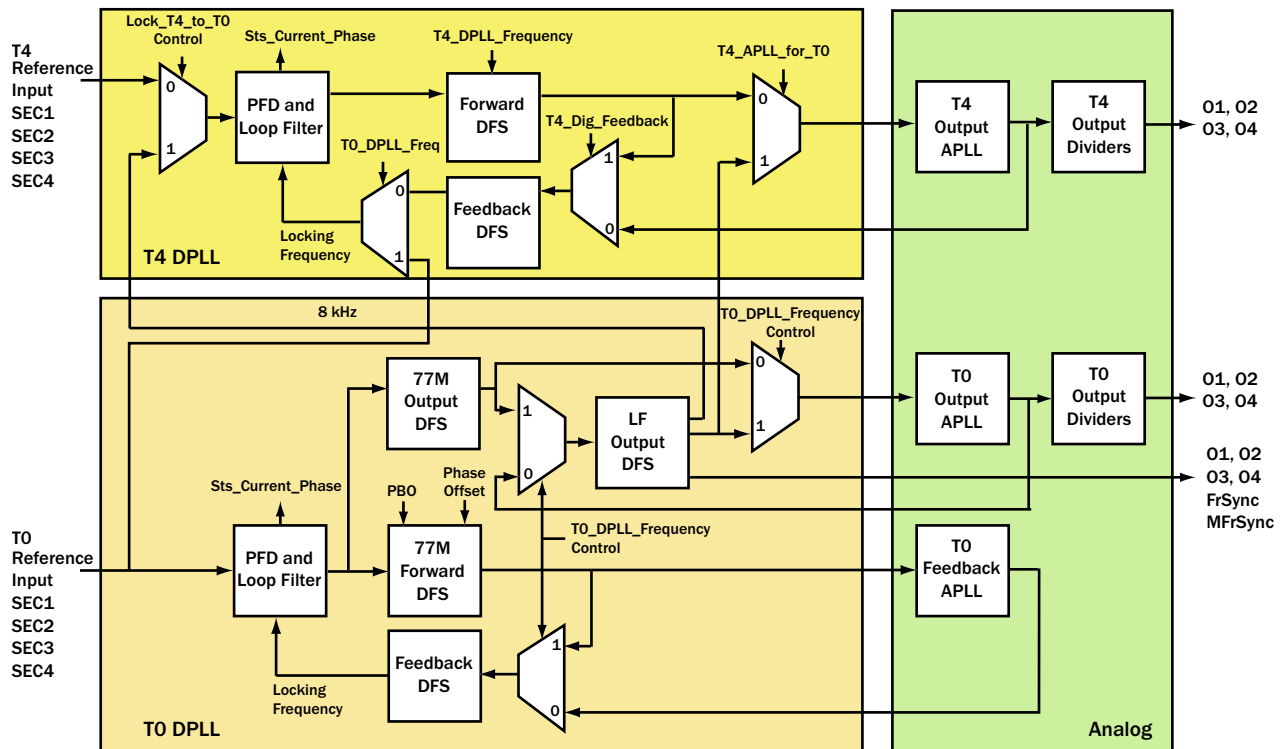
**Figure 10 PLL Block Diagram**

F8522D\_017BLOCKDIA\_01

The T4 output APLL block is also for multiplying and filtering. The input to the T4 output APLL can come either from the T4 forward DFS block or from the T0 path. The input to the T4 output APLL can be programmed to be one of the following:

- Output from the T4 forward DFS block (12E1, 24DS1, 16E1, 16DS1, E3, DS3, OC-N),
- 12E1 from T0,
- 16E1 from T0,
- 24DS1 from T0,
- 16DS1 from T0.

The frequency generated from the T4 output APLL block is four times its input frequency i.e. 311.04 MHz when used with a 77.76 MHz input. The T4 output APLL is subsequently divided by 2, 4, 8, 12, 16, 48 and 64 and these are available at the O1 to O4 outputs.

The outputs O1 to O4 are driven from either the T4 or the T0 path. The FrSync and MFrSync outputs are always generated from the T0 path. Reg.7A bit 7 selects whether the source of the 2 kHz and 8 kHz outputs available from O1 to O4 is derived from either the T0 or the T4 paths.

### Output Frequency Configuration Steps

The output frequency selection is performed in the following steps:

- Does the application require the use of the T4 path as an independent PLL path or not. If not, then the T4 path can be utilized to produce extra frequencies locked to the T0 path.
- Refer to Table 13, Frequency Divider Look-up, to choose a set of output frequencies- one for each path, T4 and T0. Only one set of frequencies can be generated simultaneously from each path.
- Refer to the Table 13 to determine the required APLL frequency to support the frequency set.
- Refer to Table 14, T0 APLL Frequencies, and Table 15, T4 APLL Frequencies, to determine what mode the T0 and T4 paths need to be configured in, considering the output jitter level.
- Refer to Table 16, O1 to O4 Output Frequency Selection, and the column headings in Table 13, Frequency Divider Look-up, to select the appropriate frequency from either of the APLLs on each output as required.

**Table 11 Output Reference Source Selection Table**

Port Name	Output Port Technology	Frequencies Supported
O1	LVDS/PECL (LVDS default)	Frequency selection as per Table 12 and Table 16
O2	TTL/CMOS	
O3	TTL/CMOS	
O4	TTL/CMOS	
FrSync	TTL/CMOS	FrSync, 8 kHz programmable pulse width and polarity, see Reg. 7A.
MFrSync	TTL/CMOS	MFrSync, 2 kHz programmable pulse width and polarity, see Reg. 7A.

Note...1.544 MHz/2.048 MHz are shown for SONET/SDH respectively. Pin SONSDHB controls default, when High SONET is default.

**Table 12 Output Frequency Selection**

Frequency (MHz, unless stated otherwise)	T0 DPLL Mode	T4 DPLL Mode	T4 APLL Input Mux	Jitter Level (typ)	
				rms (ps)	pk-pk (ns)
2 kHz	77.76 MHz Analog	-	-	60	0.6
2 kHz	Any digital feedback mode	-	-	1400	5
8 kHz	77.76 MHz Analog	-	-	60	0.6
8 kHz	Any digital feedback mode	-	-	1400	5
1.536 (not O4)	-	12E1 mode	Select T4 DPLL	500	2.3
1.536 (not O4)	-	-	Select T0 DPLL 12E1	250	1.5
1.544 (not O4)	-	16DS1 mode	Select T4 DPLL	200	1.2
1.544 (not O4)	-	-	Select T0 DPLL 16DS1	150	1.0
1.544 via Digital1, or Digital2 (not O1)	77.76 MHz Analog	-	-	3800	13
1.544 via Digital1, or Digital2 (not O1)	Any digital feedback mode	-	-	3800	18
2.048	-	12E1 mode	Select T4 DPLL	500	2.3
2.048	-	-	Select T0 DPLL 12E1	250	1.5
2.048 (not O4)	-	16E1 mode	Select T4 DPLL	400	2.0
2.048 (not O4)	-	-	Select T0 DPLL 16E1	220	1.2
2.048 (not O1)	12E1 mode	-	-	900	4.5
2.048 via Digital1, or Digital2 (not O1)	77.76 MHz Analog	-	-	3800	13

**ADVANCED COMMS & SENSING FINAL DATASHEET**
**Table 12 Output Frequency Selection (cont...)**

Frequency (MHz, unless stated otherwise)	T0 DPLL Mode	T4 DPLL Mode	T4 APLL Input Mux	Jitter Level (typ)	
				rms (ps)	pk-pk (ns)
2.048 via Digital1, or Digital2 (not O1)	Any digital feedback mode	-	-	3800	18
2.059	-	16DS1 mode	Select T4 DPLL	200	1.2
2.059	-	-	Select T0 DPLL 16DS1	150	1.0
2.059 (not O1)	16DS1 mode	-	-	760	2.6
2.316 (not O4)	-	24DS1 mode	Select T4 DPLL	110	0.75
2.316 (not O4)	-	-	Select T0 DPLL 24DS1	110	0.75
2.731	-	16E1 mode	Select T4 DPLL	400	1.5
2.731	-	-	Select T0 DPLL 16E1	220	1.2
2.731 (not O1)	16E1 mode	-	-	250	1.6
2.796 (not O4)	-	DS3 mode	Select T4 DPLL	110	1.0
3.088	-	24DS1 mode	Select T4 DPLL	110	0.75
3.088	-	-	Select T0 DPLL 24DS1	110	0.75
3.088 (not O1)	24DS1 mode	-	-	110	0.75
3.088 via Digital1, or Digital2 (not O1)	77.76 MHz Analog	-	-	3800	13
3.088 via Digital1, or Digital2 (not O1)	Any digital feedback mode	-	-	3800	18
3.728	-	DS3 mode	Select T4 DPLL	110	1.0
4.096 via Digital1, or Digital2 (not O1)	77.76 MHz Analog	-	-	3800	13
4.096 via Digital1, or Digital2 (not O1)	Any digital feedback mode	-	-	3800	18
4.296 (not O4)	-	E3 mode	Select T4 DPLL	120	1.0
4.86 (not O4)	-	77.76 MHz mode	Select T4 DPLL	60	0.6
5.728	-	E3 mode	Select T4 DPLL	120	1.0
6.144	12E1 mode	-	-	900	4.5
6.144	-	12E1 mode	Select T4 DPLL	500	2.3
6.144	-	-	Select T0 DPLL 12E1	250	1.5
6.176	16DS1 mode	-	-	760	2.6
6.176	-	16DS1 mode	Select T4 DPLL	200	1.2
6.176	-	-	Select T0 DPLL 16DS1	150	1.0

## ADVANCED COMMS & SENSING FINAL DATASHEET

Table 12 Output Frequency Selection (cont...)

Frequency (MHz, unless stated otherwise)	T0 DPLL Mode	T4 DPLL Mode	T4 APLL Input Mux	Jitter Level (typ)	
				rms (ps)	pk-pk (ns)
6.176 via Digital1, or Digital2 (not O1)	77.76 MHz Analog	-	-	3800	13
6.176 via Digital1, or Digital2 (not O1)	Any digital feedback mode	-	-	3800	18
6.48	-	77.76 MHz mode	Select T4 DPLL	60	0.6
6.48 (not O1)	77.76 MHz analog	-	-	60	0.6
6.48 (not O1)	77.76 MHz digital	-	-	60	0.6
8.192	12E1 mode	-	-	900	4.5
8.192	16E1 mode	-	-	250	1.6
8.192	-	16E1 mode	Select T4 DPLL	400	2.0
8.192	-	-	Select T0 DPLL 16E1	220	1.2
8.192 via Digital1, or Digital2 (not O1)	77.76 MHz Analog	-	-	3800	13
8.192 via Digital1, or Digital2 (not O1)	Any digital feedback mode	-	-	3800	18
8.235	16DS1 mode	-	-	760	2.6
9.264	24DS1 mode	-	-	110	0.75
9.264	-	24DS1 mode	Select T4 DPLL	110	0.75
9.264	-	-	Select T0 DPLL 24DS1	110	0.75
10.923	16E1 mode	-	-	250	1.6
11.184	-	DS3 mode	Select T4 DPLL	110	1.0
12.288	12E1 mode	-	-	900	4.5
12.288	-	12E1 mode	Select T4 DPLL	500	2.3
12.288	-	-	Select T0 DPLL 12E1	250	1.5
12.352	24DS1 mode	-	-	110	0.75
12.352	16DS1 mode	-	-	760	2.6
12.352	-	16DS1 mode	Select T4 DPLL	200	1.2
12.352	-	-	Select T0 DPLL 16DS1	150	1.0
12.352 via Digital1, or Digital2 (not O1)	77.76 MHz Analog	-	-	3800	13
12.352 via Digital1, or Digital2 (not O1)	Any digital feedback mode	-	-	3800	18
16.384	12E1 mode	-	-	900	4.5
16.384	16E1 mode	-	-	250	1.6



## ADVANCED COMMS & SENSING FINAL DATASHEET

Table 12 Output Frequency Selection (cont...)

Frequency (MHz, unless stated otherwise)	T0 DPLL Mode	T4 DPLL Mode	T4 APLL Input Mux	Jitter Level (typ)	
				rms (ps)	pk-pk (ns)
16.384	-	16E1 mode	Select T4 DPLL	400	2.0
16.384	-	-	Select T0 DPLL 16E1	220	1.2
16.384 via Digital1, or Digital2 (not O1)	77.76 MHz Analog	-	-	3800	13
16.384 via Digital1, or Digital2 (not O1)	Any digital feedback mode	-	-	3800	18
16.469	16DS1 mode	-	-	760	2.6
17.184	-	E3 mode	Select T4 DPLL	120	1.0
18.528	24DS1 mode	-	-	110	0.75
18.528	-	24DS1 mode	Select T4 DPLL	110	0.75
18.528	-	-	Select T0 DPLL 24DS1	110	0.75
19.44	77.76 MHz analog	-	-	60	0.6
19.44	77.76 MHz digital	-	-	60	0.6
19.44	-	77.76MHz mode	Select T4 DPLL	60	0.6
21.845	16E1 mode	-	-	250	1.6
22.368	-	DS3 mode	Select T4 DPLL	110	1.0
24.576	12E1 mode	-	-	900	4.5
24.576	-	12E1 mode	Select T4 DPLL	500	2.3
24.576	-	-	Select T0 DPLL 12E1	250	1.5
24.704	24DS1 mode	-	-	110	0.75
24.704	16DS1 mode	-	-	760	2.6
24.704	-	16DS1 mode	Select T4 DPLL	200	1.2
24.704	-	-	Select T0 DPLL 16DS1	150	1.0
25.92	77.76 MHz analog	-	-	60	0.6
25.92	77.76 MHz digital	-	-	60	0.6
32.768	16E1 mode	-	-	250	1.6
32.768	-	16E1 mode	Select T4 DPLL	400	2.0
32.768	-	-	Select T0 DPLL 16E1	220	1.2
34.368	-	E3 mode	Select T4 DPLL	120	1.0
37.056	24DS1 mode	-	-	110	0.75
37.056	-	24DS1 mode	Select T4 DPLL	110	0.75

## ADVANCED COMMS & SENSING FINAL DATASHEET

Table 12 Output Frequency Selection (cont...)

Frequency (MHz, unless stated otherwise)	T0 DPLL Mode	T4 DPLL Mode	T4 APLL Input Mux	Jitter Level (typ)	
				rms (ps)	pk-pk (ns)
37.056	-	-	Select T0 DPLL 24DS1	110	0.75
38.88	77.76 MHz analog	-	-	60	0.6
38.88	77.76 MHz digital	-	-	60	0.6
38.88	-	77.76 MHz mode	Select T4 DPLL	60	0.6
44.736	-	DS3 mode	Select T4 DPLL	110	1.0
49.152 (O4 only)	-	12E1 mode	Select T4 DPLL	500	2.3
49.152 (O4 only)	-	-	Select T0 DPLL 12E1	250	1.5
49.152 (O1 only)	12E1 mode	-	-	900	4.5
49.408 (O4 only)	-	16DS1 mode	Select T4 DPLL	200	1.2
49.408 (O4 only)	-	-	Select T0 DPLL 16DS1	150	1.0
49.408 (O1 only)	16DS1 mode	-	-	760	2.6
51.84	77.76 MHz analog	-	-	60	0.6
51.84	77.76 MHz digital	-	-	60	0.6
65.536 (O4 only)	-	16E1 mode	Select T4 DPLL	400	2.0
65.536 (O4 only)	-	-	Select T0 DPLL 16E1	220	1.2
65.536 (O1 only)	16E1 mode	-	-	250	1.6
68.736	-	E3 mode	Select T4 DPLL	120	1.0
74.112 (O4 only)	-	24DS1 mode	Select T4 DPLL	110	0.75
74.112 (O4 only)	-	-	Select T0 DPLL 24DS1	110	0.75
74.112 (O1 only)	24DS1 mode	-	-	110	0.75
77.76	77.76 MHz analog	-	-	60	0.6
77.76	77.76 MHz digital	-	-	60	0.6
77.76	-	77.76 MHz mode	Select T4 DPLL	60	0.6
89.472 (O4 only)	-	DS3 mode	Select T4 DPLL	110	1.0
98.304 (O1 only)	12E1 mode	-	-	900	4.5
98.816 (O1 only)	16DS1 mode	-	-	760	2.6
131.07 (O1 only)	16E1 mode	-	-	250	1.6
137.47 (O4 only)	-	E3 mode	Select T4 DPLL	120	1.0
148.22 (O1 only)	24DS1 mode	-	-	110	0.75

**Table 12 Output Frequency Selection (cont...)**

Frequency (MHz, unless stated otherwise)	T0 DPLL Mode	T4 DPLL Mode	T4 APLL Input Mux	Jitter Level (typ)	
				rms (ps)	pk-pk (ns)
155.52 (O4 only)	-	77.76 MHz mode	Select T4 DPLL	60	0.6
155.52 (O1 only)	77.76 MHz analog	-	-	60	0.6
155.52 (O1 only)	77.76 MHz digital	-	-	60	0.6
311.04 (O1 only)	77.76 MHz analog	-	-	60	0.6
311.04 (O1 only)	77.76 MHz digital	-	-	60	0.6

**Table 13 Frequency Divider Look-up**

APLL Frequency	APLL/2	APLL/4	APLL/6	APLL/8	APLL/12	APLL/16	APLL/48	APLL/64
311.04	155.52	77.76	51.84	38.88	25.92	19.44	6.48	4.86
274.944	137.472	68.376	-	34.368	-	17.184	5.728	4.296
178.944	89.472	44.736	-	22.368	-	11.184	3.728	2.796
148.224	74.112	37.056	24,704	18.528	12.352	9.264	3.088	2.316
131.072	65.536	32.768	21.84533	16.384	10.92267	8.192	2.730667	2.048
98.816	49.408	24.704	16.46933	12.352	8.234667	6.176	2.058667	1.544
98.304	49.152	24.576	16.384	12.288	8.192	6.144	2.048	1.536

Note...All frequencies in MHz

**Table 14 TO APLL Frequencies**

TO APLL Frequency	TO Mode	TO DPLL Frequency Control Register Bits Reg. 65 Bits[2:0]	Output Jitter Level ns (pk-pk)
311.04 MHz	Normal (digital feedback)	000	<0.5
311.04 MHz	Normal (analog feedback)	001	<0.5
98.304 MHz	12E1 (digital feedback)	010	<2
131.072 MHz	16E1 (digital feedback)	011	<2
148.224 MHz	24DS1 (digital feedback)	100	<2
98.816 MHz	16DS1 (digital feedback)	101	<2
-	Do not use	110	-
-	Do not use	111	-

**Table 15 T4 APLL Frequencies**

T4 APLL Frequency	T4 Mode	T4 Forward DFS Frequency (MHz)	T4 DPLL Freq. Control Register Bits Reg. 64 Bits [2:0]	T4 APLL for TO Enable Register Bit Reg. 65 Bit 6	TO Freq. to T4 APLL Register Bits Reg. 65 Bits [5:4]	Output Jitter Level ns (pk-pk)
311.04 MHz	Squelched	77.76	000	0	XX	<0.5
311.04 MHz	Normal	77.76	001	0	XX	<0.5
98.304 MHz	12E1	24.576	010	0	XX	<0.5
131.072 MHz	16E1	32.768	011	0	XX	<0.5
148.224 MHz	24DS1	37.056 (2*18.528)	100	0	XX	<0.5
98.816 MHz	16DS1	24.704	101	0	XX	<0.5
274.944 MHz	E3	68.736 (2*34.368)	110	0	XX	<0.5
178.944 MHz	DS3	44.736	111	0	XX	<0.5
98.304 MHz	T0-12E1	-	XXX	1	00	<2
131.072 MHz	T0-16E1	-	XXX	1	01	<2
148.224 MHz	T0-24DS1	-	XXX	1	10	<2
98.816 MHz	T0-16DS1	-	XXX	1	11	<2

**Table 16 O1 to O4 Output Frequency Selection**

Value in Register	Output Frequency for given "Value in Register" for each Output Port's <i>cnfg_output_frequency</i> Register			
	01, Reg. 62 Bits [7:4]	02, Reg. 60 Bits [7:4]	03, Reg. 61 Bits [3:0]	04, Reg. 62 Bits [3:0]
0000	Off	Off	Off	Off
0001	2 kHz	2 kHz	2 kHz	2 kHz
0010	8 kHz	8 kHz	8 kHz	8 kHz
0011	TO APLL/2	Digital2	Digital2	Digital2
0100	Digital1	Digital1	Digital1	Digital1
0101	TO APLL/1	TO APLL/48	TO APLL/48	TO APLL/48
0110	TO APLL/16	TO APLL/16	TO APLL/16	TO APLL/16
0111	TO APLL/12	TO APLL/12	TO APLL/12	TO APLL/12
1000	TO APLL/8	TO APLL/8	TO APLL/8	TO APLL/8
1001	TO APLL/6	TO APLL/6	TO APLL/6	TO APLL/6
1010	TO APLL/4	TO APLL/4	TO APLL/4	TO APLL/4
1011	T4 APLL/64	T4 APLL/64	T4 APLL/64	T4 APLL/2
1100	T4 APLL/48	T4 APLL/48	T4 APLL/48	T4 APLL/48
1101	T4 APLL/16	T4 APLL/16	T4 APLL/16	T4 APLL/16
1110	T4 APLL/8	T4 APLL/8	T4 APLL/8	T4 APLL/8
1111	T4 APLL/4	T4 APLL/4	T4 APLL/4	T4 APLL/4

### "Digital" Frequencies

It can be seen from Table 16 (O1 to O4 output frequency selection) that frequencies listed as Digital1 and Digital2 can be selected. Digital1 is a single frequency selected from the range shown in Table 17. Digital2 is another single frequency selected from the same range. The T0 LF output DFS block shown in the diagram and clocked either by the T0 77M output DFS block or via the T0 output APLL, generates these two frequencies. The input clock frequency of the DFS is always 77.76 MHz and as such has a period of approximately 12 ns. The jitter generated on the Digital outputs is relatively high, due to the fact that they do not pass through an APLL for jitter filtering. The minimum level of jitter is when the T0 path is in analog feedback mode, when the pk-pk jitter will be approximately 12 ns (equivalent to a period of the DFS clock). The maximum jitter is generated when in digital feedback mode, when the total is approximately 17 ns.

### FrSync, MFrSync, 2 kHz and 8 kHz Clock Outputs

It can be seen from Table 16 (O1 to O4 Output Frequency Selection) that frequencies listed as 2 kHz and 8 kHz can be selected. Whilst the FrSync and MFrSync outputs are always supplied from the T0 path, the 2 kHz and 8 kHz options available from the O1 to O4 outputs are all supplied from either the T0 or T4 path (Reg. 7A bit 7).

The outputs can be either clocks (50:50 mark-space) or pulses and can be inverted. When pulses are configured on the output, the pulse width will be one cycle of the output of O3 (O3 must be configured to generate at least 1544 kHz to ensure that pulses are generated correctly). Figure 11 shows the various options with the 8 kHz controls in Reg. 7A. There is an identical arrangement with Reg. 7A bits [1:0] and the 2 kHz/MFrSync outputs. Outputs FrSync and MFrSync can be disabled via Reg. 63 bits [7:6].

Figure 11 Control of 8k Options.

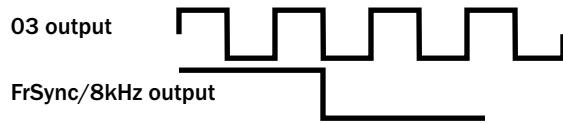

a) Clock non-inverted, Reg. 7A[3:2] = 00

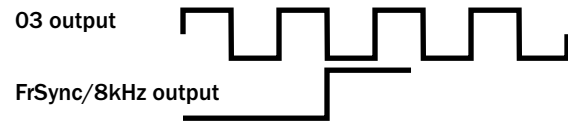

c) Clock inverted, Reg. 7A[3:2] = 10

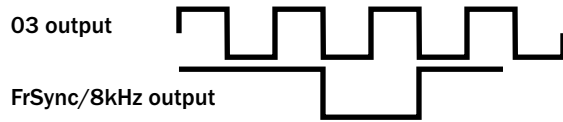

b) Pulse non-inverted, Reg. 7A[3:2] = 01

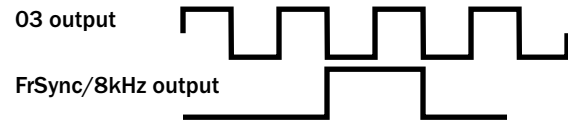

d) Pulse inverted, Reg. 7A[3:2] = 11

F8522\_016outputoptions8k\_01

Table 17 Digital Frequency Selections

Digital1 Control Reg.39 Bits [5:4]	Digital1 SONET/ SDH Reg. 38 Bit5	Digital1 Freq. (MHz)
00	0	2.048
01	0	4.096
10	0	8.192
11	0	16.384
00	1	1.544
01	1	3.088
10	1	6.176
11	1	12.352

Digital2 Control Reg. 39 Bits[7:6]	Digital2 SONET/SDH Reg.38 Bit6	Digital2 Freq. (MHz)
00	0	2.048
01	0	4.096
10	0	8.192
11	0	16.384
00	1	1.544
01	1	3.088
10	1	6.176
11	1	12.352

## Power-On Reset

The Power-On Reset (PORB) pin resets the device if forced Low. The reset is asynchronous, the minimum Low pulse width is 5 ns. Reset is needed to initialize all of the register values to their defaults. Reset must be asserted at power on, and may be re-asserted at any time to restore defaults. This is implemented simply using an external capacitor to GND along with the internal pull-up resistor. The ACS8522A is held in a reset state for 250 ms after the PORB pin has been pulled High. In normal operation PORB should be held High.

## Serial Interface

The ACS8522A device has a serial interface which can be SPI compatible.

The Motorola SPI convention is such that address and data is transmitted and received MSB first. On the

ACS8522A address and data are transmitted and received LSB first. Address, read/write control and data on the SDI pin are latched into the device on the rising edge of the SCLK. During a read operation, serial data output on the SDO pin can be read out of the device on either the rising or falling edge of the SCLK depending on the logic level of CLKE. For standard Motorola SPI compliance, data should be clocked out of the SDO pin on the rising edge of the SCLK so that it may be latched into the microprocessor on the falling edge of the SCLK. Figure 12 and Figure 13 show the timing diagrams of write and read accesses for this interface.

During read access, the output data SDO is clocked out on the rising edge of SCLK when the active edge selection control bit CLKE is 0 and on the falling edge when CLKE is 1.

The serial interface clock (SCLK) is not required to run between accesses (i.e., when CSB = 1).

Figure 12 and Figure 13 show the timing diagrams of read and write accesses for this mode.

**Figure 12 Read Access Timing for SERIAL Interface**

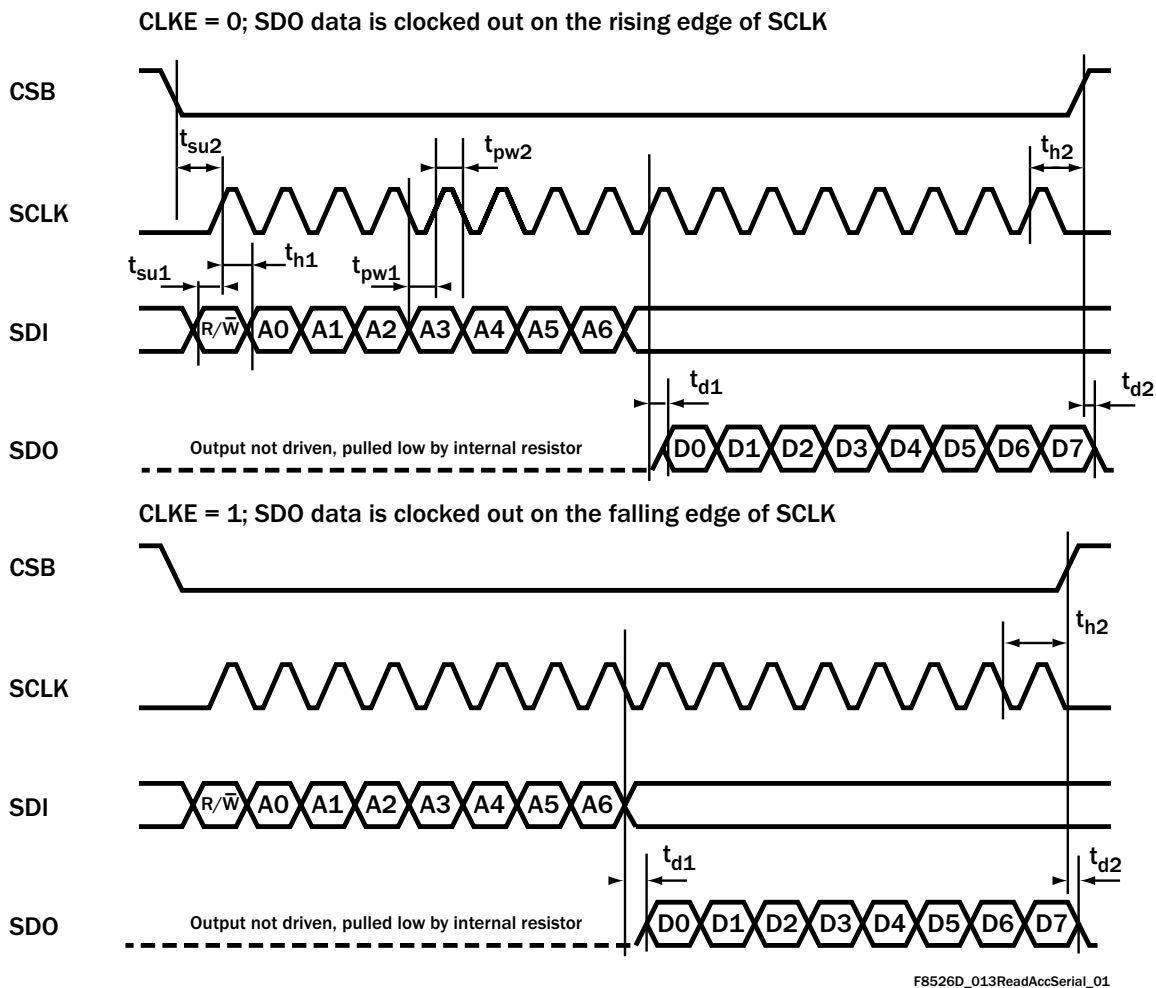

**Table 18 Read Access Timing for SERIAL Interface (For use with Figure 12)**

Symbol	Parameter	MIN	TYP	MAX
$t_{su1}$	Setup SDI valid to SCLK <sub>rising edge</sub>	4 ns	-	-
$t_{su2}$	Setup CSB <sub>falling edge</sub> to SCLK <sub>rising edge</sub>	14 ns	-	-
$t_{d1}$	Delay SCLK <sub>rising edge</sub> (SCLK <sub>falling edge</sub> for CLKE = 1) to SDO valid	-	-	18 ns
$t_{d2}$	Delay CSB <sub>rising edge</sub> to SDO high-Z	-	-	16 ns
$t_{pw1}$	SCLK Low time	22 ns	-	-
$t_{pw2}$	SCLK High time	22 ns	-	-
$t_{h1}$	Hold SDI valid after SCLK <sub>rising edge</sub>	6 ns	-	-
$t_{h2}$	Hold CSB Low after SCLK <sub>rising edge</sub> , for CLKE = 0 Hold CSB Low after SCLK <sub>falling edge</sub> , for CLKE = 1	5 ns	-	-
$t_p$	Time between consecutive accesses (CSB <sub>rising edge</sub> to CSB <sub>falling edge</sub> )	10 ns	-	-

Figure 13 Write Access Timing for SERIAL Interface

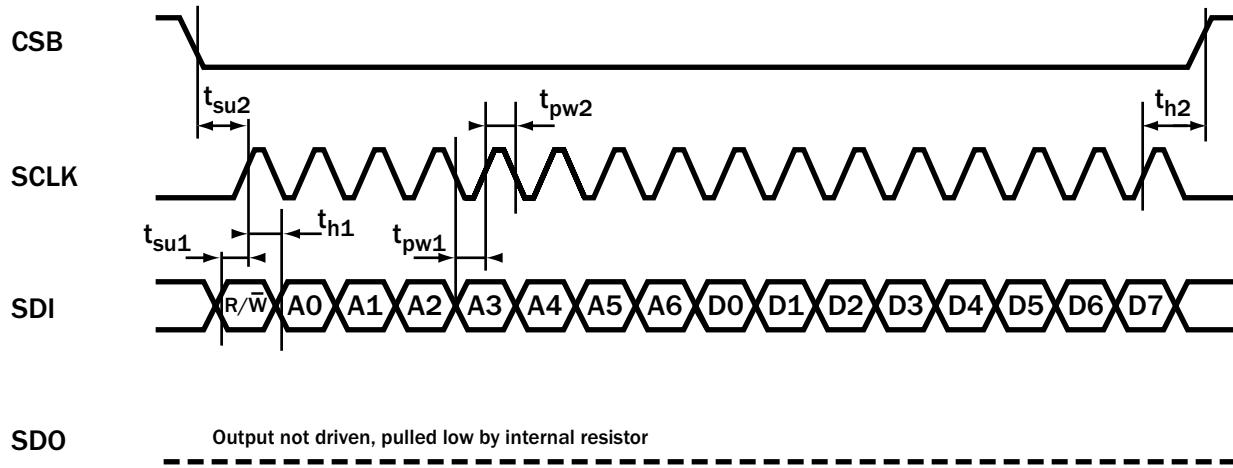

F8525D\_014WriteAccSerial\_01

Table 19 Write Access Timing for SERIAL Interface (For use with Figure 13)

Symbol	Parameter	MIN	TYP	MAX
$t_{su1}$	Setup SDI valid to SCLK <sub>rising edge</sub>	4 ns	-	-
$t_{su2}$	Setup CSB <sub>falling edge</sub> to SCLK <sub>rising edge</sub>	14 ns	-	-
$t_{pw1}$	SCLK Low time	22 ns	-	-
$t_{pw2}$	SCLK High time	22 ns	-	-
$t_{h1}$	Hold SDI valid after SCLK <sub>rising edge</sub>	6 ns	-	-
$t_{h2}$	Hold CSB Low after SCLK <sub>rising edge</sub>	5 ns	-	-
$t_p$	Time between consecutive accesses (CSB <sub>rising edge</sub> to CSB <sub>falling edge</sub> )	10 ns	-	-



## Register Map

Each Register, or register group, is described in the following Register Map (Table 20) and subsequent Register Description Tables.

## Register Organization

The ACS8522A SETS LITE uses a total of 95 eight-bit register locations, identified by a Register Name and corresponding hexadecimal Register Address. They are presented here in ascending order of Reg. address. and each Register is organized with the most-significant bit positioned in the left-most bit, and bit significance decreasing towards the right-most bit. Some registers carry several individual data fields of various sizes, from single-bit values (e.g. flags) upwards. Several data fields are spread across multiple registers, as shown in the Register Map, Table 20. Shaded areas in the map are “don’t care” and writing either 0 or 1 to them will not affect any function of the device. Bits labelled “Set to 0” or “Set to 1” must be set as stated during initialization of the device, either following power-up, or after a power-on reset (POR). Failure to correctly set these bits may result in the device operating in an unexpected way.

**CAUTION! Do not write to any undefined register addresses as this may cause the device to operate in a test mode. If an undefined register has been inadvertently addressed, the device should be reset to ensure the undefined registers are at default values.**

### Multi-word Registers

For multi-word registers (e.g. Reg. 70 and 71), all the words have to be written to their separate addresses, and without any other access taking place, before their combined value can take effect. If the sequence is interrupted the sequence of writes will be ignored. Reading a multi-word address freezes the other address words of a multi-word address so that the bytes all correspond to the same complete word.

## Register Access

Most registers are of one of two types, configuration registers or status registers, the exceptions being the *chip\_id* and *chip\_revision* registers. Configuration registers may be written to or read from at any time (the complete 8-bit register must be written, even if only one bit is being modified). All status registers may be read at any time and, in some status registers (such as the *sts\_interrupts* register), any individual data field may be

cleared by writing a 1 into each bit of the field (writing a 0 value into a bit will not affect the value of the bit).

### Configuration Registers

Each configuration register reverts to a default value on power-up or following a reset. Most default values are fixed, but some can be pin-set. All configuration registers can be read out over the serial port.

### Status Registers

The Status Registers contain readable registers. They may all be read from outside the chip but are not writeable from outside the chip (except for a clearing operation). All status registers are read via shadow registers to avoid data hits due to dynamic operation.

### Interrupt Enable and Clear

Interrupt requests are flagged on pin INTREQ; the active state (*High* or *Low*) is programmable and the pin can either be driven, or set to high impedance when non-active (Reg 7D refers).

Bits in the interrupt status register are set (*High*) by the following conditions;

1. Any reference source becoming valid or going invalid.
2. A change in the operating state (e.g. Locked, Holdover)
3. A brief loss of the currently selected reference source.

All interrupt sources, see Reg. 05, Reg. 06 and Reg. 08, are maskable via the mask register, each one being enabled by writing a 1 to the appropriate bit. Any unmasked bit set in the interrupt status register will cause the interrupt request pin to be asserted. All interrupts are cleared by writing a 1 to the bit(s) to be cleared in the status register. When all pending unmasked interrupts are cleared the interrupt pin will go inactive.

### Defaults

Each Register is given a defined default value at reset and these are listed in the Map and Description Tables. However, some read-only status registers may not necessarily show the same default values after reset as those given in the tables. This is because they reflect the status of the device which may have changed in the time it takes to carry out the read, or through reasons of configuration. In the same way, the default values given for shaded areas could also take different values to those stated.

**Table 20 Register Map**

Register Name	Address (hex)	Default (hex)	Data Bit										
			7 (MSB)	6	5	4	3	2	1	0 (LSB)			
RO = Read Only R/W = Read/Write													
chip_id (RO)	00	4A	Device part number [7:0] 8 least significant bits of the chip ID										
	01	21	Device part number [15:8] 8 most significant bits of the chip ID										
chip_revision (RO)	02	02	Chip revision number [7:0]										
test_register1 (R/W, Bit 7 RO)	03	14	phase_alarm	disable_180		resync_analog	Set to zero	8K edge polarity	Set to zero	Set to zero			
sts_interrupts (R/W)	05	FF	SEC3 valid change				SEC2 valid change	SEC1 valid change					
	06	3F	operating_mode	main_ref_failed								SEC4 valid change	
sts_current_DPLL_frequency, see OC/OD	07	00	Bits [18:16] of current DPLL frequency										
sts_interrupts (R/W)	08	50		T4_status									
sts_operating (RO)	09	41		T4_DPLL_Lock	TO_DPLL_freq_soft_alarm	T4_DPLL_freq_soft_alarm			TO_DPLL_operating_mode				
sts_priority_table (RO)	0A	00	Highest priority validated source				Currently selected source						
	0B	00	3 <sup>rd</sup> highest priority validated source				2 <sup>nd</sup> highest priority validated source						
sts_current_DPLL_frequency[7:0] (RO)	0C	00	Bits [7:0] of current DPLL frequency										
	0D	00	Bits [15:8] of current DPLL frequency										
	07	00	Bits [18:16] of current DPLL frequency										
sts_sources_valid (RO)	0E	00	SEC3				SEC2	SEC1					
	0F	00										SEC4	
sts_reference_sources (RO) Status of inputs:			Out-of-band alarm (soft)	Out-of-band alarm (hard)	No activity alarm	Phase lock alarm	Out-of-band alarm (soft)	Out-of-band alarm (hard)	No activity alarm	Phase lock alarm (soft)			
Inputs SEC1 & SEC2	11	66	Status of SEC2 Input				Status of SEC1 Input						
SEC3	13	66	Status of SEC3 Input										
SEC4	14	66	Status of SEC4 Input										
cnfg_ref_selection_priority (R/W) (SEC2 & SEC1)	19	32	programmed_priority <SEC2>				programmed_priority <SEC1>						
	(SEC3)	1B	programmed_priority <SEC3>										
	(SEC4)	1C	programmed_priority <SEC4>										
cnfg_ref_source_frequency (R/W)	(SEC1)	22	00	divn_SEC1	lock8k_SEC1	bucket_id_SEC1	reference_source_frequency_SEC1						
	(SEC2)	23	00	divn_SEC2	lock8k_SEC2	bucket_id_SEC2	reference_source_frequency_SEC2						
	(SEC3)	27	03	divn_SEC3	lock8k_SEC3	bucket_id_SEC3	reference_source_frequency_SEC3						
	(SEC4)	28	03	divn_SEC4	lock8k_SEC4	bucket_id_SEC4	reference_source_frequency_SEC4						
cnfg_operating_mode (R/W)	32	00	TO_DPLL_operating_mode										
force_select_reference_source (R/W)	33	0F	forced_reference_source										
cnfg_input_mode (R/W)	34	CA	Set to zero	phalarm_timeout	XO_edge	man_holdover	extsync_en	ip_sonsdhub		reversion_mode			
cnfg_T4_path (R/W)	35	40	lock_T4_to TO	T4_dig_feedback			T4_forced_reference_source						
cnfg_dig_outputs_sonsdh (R/W)	38	0D		dig2_sonsdh	dig1_sonsdh								
cnfg_digital_frequencies (R/W)	39	08	digital2_frequency		digital1_frequency								
cnfg_differential_outputs (R/W)	3A	C2	01_LVDS_PECL										
cnfg_auto_bw_sel	3B	FD	auto_BW_sel				TO_lim_int						
cnfg_nominal_frequency [7:0] (R/W)	3C	99	Nominal frequency [7:0]										
	3D	99	Nominal frequency [15:8]										
cnfg_holdover_frequency [7:0] (R/W)	3E	00	Holdover frequency [7:0]										
	3F	00	Holdover frequency [15:8]										
cnfg_holdover_modes (R/W)	40	88	auto_averaging	fast_averaging	read_average	mini_holdover_mode	Holdover frequency [18:16] (with Registers 3E and 3F above)						
cnfg_DPLL_freq_limit (R/W) [7:0] [9:8]	41	76	DPLL frequency offset limit [7:0]										
	42	00	DPLL frequency offset limit [9:8]										
cnfg_interrupt_mask (R/W) [7:0] [15:8]	43	00	SEC3 interrupt not masked				SEC2 interrupt not masked	SEC1 interrupt not masked					
	44	00	operating_mode interrupt not masked	main_ref_failed interrupt not masked								SEC4 interrupt not masked	

Table 20 Register Map (cont...)

Register Name	Address (hex)	Default (hex)	Data Bit											
			7 (MSB)	6	5	4	3	2	1	0 (LSB)				
RO = Read Only R/W = Read/Write														
cnfg_interrupt_mask cont.[23:16]	45	00		T4_status interrupt not masked										
cnfg_freq_divn (R/W)	[7:0]	46	divn_value [7:0]											
	[13:8]	47	divn_value [13:8]											
cnfg_monitors (R/W)	48	05	freq_mon_clk	los_flag_on_TDO	ultra_fast_switch	ext_switch	PBO_freeze	PBO_en	freq_monitor_soft_enable	freq_monitor_hard_enable				
cnfg_freq_mon_threshold (R/W)	49	23	soft_frequency_alarm_threshold [3:0]				hard_frequency_alarm_threshold [3:0]							
cnfg_current_freq_mon_threshold (R/W)	4A	23	current_soft_frequency_alarm_threshold [3:0]				current_hard_frequency_alarm_threshold [3:0]							
cnfg_registers_source_select (R/W)	4B	00				T4_TO_select	frequency_measurement_channel_select [3:0]							
sts_freq_measurement (RO)	4C	00	freq_measurement_value [7:0]											
cnfg_DPLL_soft_limit (R/W)	4D	8E	Freq limit Phase loss enable	DPLL Frequency Soft Alarm Limit [6:0] Resolution = 0.628 ppm										
cnfg_upper_threshold_0 (R/W)	50	06	Leaky Bucket Configuration 0: Activity alarm set threshold [7:0]											
cnfg_lower_threshold_0 (R/W)	51	04	Leaky Bucket Configuration 0: Activity alarm reset threshold [7:0]											
cnfg_bucket_size_0 (R/W)	52	08	Leaky Bucket Configuration 0: Activity alarm bucket size [7:0]											
cnfg_decay_rate_0 (R/W)	53	01									Leaky Bucket Cfg 0: decay_rate [1:0]			
cnfg_upper_threshold_1 (R/W)	54	06	Leaky Bucket Configuration 1: Activity alarm set threshold [7:0]											
cnfg_lower_threshold_1 (R/W)	55	04	Leaky Bucket Configuration 1: Activity alarm reset threshold [7:0]											
cnfg_bucket_size_1 (R/W)	56	08	Leaky Bucket Configuration 1: Activity alarm bucket size [7:0]											
cnfg_decay_rate_1 (R/W)	57	01									Leaky Bucket Cfg 1: decay_rate [1:0]			
cnfg_upper_threshold_2 (R/W)	58	06	Leaky Bucket Configuration 2: Activity alarm set threshold [7:0]											
cnfg_lower_threshold_2 (R/W)	59	04	Leaky Bucket Configuration 2: Activity alarm reset threshold [7:0]											
cnfg_bucket_size_2 (R/W)	5A	08	Leaky Bucket Configuration 2: Activity alarm bucket size [7:0]											
cnfg_decay_rate_2 (R/W)	5B	01									Leaky Bucket Cfg 2: decay_rate [1:0]			
cnfg_upper_threshold_3 (R/W)	5C	06	Leaky Bucket Configuration 3: Activity alarm set threshold [7:0]											
cnfg_lower_threshold_3 (R/W)	5D	04	Leaky Bucket Configuration 3: Activity alarm reset threshold [7:0]											
cnfg_bucket_size_3 (R/W)	5E	08	Leaky Bucket Configuration 3: Activity alarm bucket size [7:0]											
cnfg_decay_rate_3 (R/W)	5F	01									Leaky Bucket Cfg 3: decay_rate [1:0]			
cnfg_output_frequency (R/W)(O2) (O3) (O4 & O1)	60	80	output_freq_O2											
	61	06					output_freq_O3							
	62	84	output_freq_O1				output_freq_O4							
(MFrSync)	63	C0	MFrSync_en	FrSync_en										
cnfg_T4_DPLL_frequency (R/W)	64	05								T4_DPLL_frequency				
cnfg_TO_DPLL_frequency (R/W)	65	01	T4 for measuring T0 phase	T4 APPL for T0 E1/DS1	T0 Freq to T4 APPL			T0_DPLL_frequency						
cnfg_T4_DPLL_bw (R/W)	66	00									T4_DPLL_bandwidth [1:0]			
cnfg_TO_DPLL_locked_bw (R/W)	67	0D									T0_DPLL_locked_bandwidth [4:0]			
cnfg_TO_DPLL_acq_bw (R/W)	69	0F									T0_acquisition_bandwidth [4:0]			
cnfg_T4_DPLL_damping (R/W)	6A	13					T4_PD2_gain_aalog_8K [6:4]		T4_damping [2:0]					
cnfg_TO_DPLL_damping (R/W)	6B	13					T0_PD2_gain_aalog_8K [6:4]		T0_damping [2:0]					
cnfg_T4_DPLL_PD2_gain (R/W)	6C	C2	T4_PD2_gain_enable	T4_PD2_gain_aalog [6:4]				T4_PD2_gain_digital [2:0]						
cnfg_TO_DPLL_PD2_gain (R/W)	6D	C2	T0_PD2_gain_enable	T0_PD2_gain_aalog [6:4]				T0_PD2_gain_digital [2:0]						
cnfg_phase_offset (R/W)	[7:0]	70	phase_offset_value[7:0]											
	[15:8]	71	phase_offset_value[15:8]											
cnfg_PBO_phase_offset (R/W)	72	00	PBO_phase_offset [5:0]											
cnfg_phase_loss_fine_limit (R/W)	73	A2	Fine limit Phase loss enable (1)	No activity for phase loss	Test bit Set to 1					phase_loss_fine_limit [2:0]				

Table 20 Register Map (cont...)

Register Name	Address (hex)	Default (hex)	Data Bit									
			7 (MSB)	6	5	4	3	2	1	0 (LSB)		
RO = Read Only R/W = Read/Write												
cnfg_phase_loss_coarse_limit (R/W)	74	85	Coarse limit Phase loss enable (2)	Wide range enable	Enable Multi Phase resp.			Phase loss coarse limit in UI pk-pk [3:0]				
cnfg_phasemon (R/W)	76	06	Input noise window enable									
sts_current_phase (RO)	[7:0]	77	00	current_phase[7:0]								
	[15:8]	78	00	current_phase[15:8]								
cnfg_phase_alarm_timeout (RO)	79	32	Timeout value in 2s intervals [5:0]									
cnfg_sync_pulses (R/W)	7A	00	2k_8k_from_T4				8k_invert	8k_pulse	2k_invert	2k_pulse		
cnfg_sync_phase (R/W)	7B	00	indep_FrSync/MFrSync	Sync_OC-N_rates					Sync_phase			
cnfg_sync_monitor (R/W)	7C	2B	ph_offset_ramp									
cnfg_interrupt (R/W)	7D	02						GPO interrupt enable	Interrupt tristate enable	Interrupt polarity enable		
cnfg_protection(R/W)	7E	85	protection_value									

### Register Descriptions

#### Address (hex): 00

<b>Register Name</b>	<i>chip_id</i>	<b>Description</b>	(RO) 8 least significant bits of the chip ID.	<b>Default Value</b>	0100 1010		
<b>Bit 7</b>	<b>Bit 6</b>	<b>Bit 5</b>	<b>Bit 4</b>	<b>Bit 3</b>	<b>Bit 2</b>	<b>Bit 1</b>	<b>Bit 0</b>
<i>chip_id[7:0]</i>							
<b>Bit No.</b>	<b>Description</b>	<b>Bit Value</b>	<b>Value Description</b>				
[7:0]	<i>chip_id</i> Least significant byte of the 2-byte device ID	4A (hex)					

#### Address (hex): 01

<b>Register Name</b>	<i>chip_id</i>	<b>Description</b>	(RO) 8 most significant bits of the chip ID.	<b>Default Value</b>	0010 0001		
<b>Bit 7</b>	<b>Bit 6</b>	<b>Bit 5</b>	<b>Bit 4</b>	<b>Bit 3</b>	<b>Bit 2</b>	<b>Bit 1</b>	<b>Bit 0</b>
<i>chip_id[15:8]</i>							
<b>Bit No.</b>	<b>Description</b>	<b>Bit Value</b>	<b>Value Description</b>				
[7:0]	<i>chip_id</i> Most significant byte of the 2-byte device ID	21 (hex)					

#### Address (hex): 02

<b>Register Name</b>	<i>chip_revision</i>	<b>Description</b>	(RO) Silicon revision of the device.	<b>Default Value</b>	0000 0010		
<b>Bit 7</b>	<b>Bit 6</b>	<b>Bit 5</b>	<b>Bit 4</b>	<b>Bit 3</b>	<b>Bit 2</b>	<b>Bit 1</b>	<b>Bit 0</b>
<i>chip_revision[7:0]</i>							
<b>Bit No.</b>	<b>Description</b>	<b>Bit Value</b>	<b>Value Description</b>				
[7:0]	<i>chip_revision</i> Silicon revision of the device	02 (hex)					

**Address (hex): 03**

Register Name	test_register1		Description	(R/W) Register containing various test controls (not normally used).		Default Value	0001 0000	
Bit 7	Bit 6	Bit 5	Bit 4	Bit 3	Bit 2	Bit 1	Bit 0	
phase_alarm	disable_180		resync_analog	Set to zero	8k Edge Polarity	Set to zero	Set to zero	
Bit No.	Description	Bit Value	Value Description					
7	phase_alarm (phase alarm (R/O)) Instantaneous result from TO DPLL	0 1	TO DPLL reporting phase locked. TO DPLL reporting phase lost.					
6	disable_180 Normally the DPLL will try to lock to the nearest edge ( $\pm 180^\circ$ ) for the first 2 seconds when locking to a new reference. If the DPLL does not determine that it is phase locked after this time, then the capture range reverts to $\pm 360^\circ$ , which corresponds to frequency and phase locking. Forcing the DPLL into frequency locking mode may reduce the time to frequency lock to a new reference by up to 2 seconds. However, this may cause an unnecessary phase shift of up to $360^\circ$ when the new and old references are very close in frequency and phase.	0 1	TO DPLL automatically determines frequency lock enable. TO DPLL forced to always frequency and phase lock.					
5	Not used.	-	-					
4	resync_analog (analog dividers re-synchronization) The analog output dividers include a synchronization mechanism to ensure phase lock at low frequencies between the input and the output.	0 1	Analog divider only synchronized during first 2 seconds after power-up. Analog dividers always synchronized. This keeps the clocks divided down from the APLL output, in sync with equivalent frequency digital clocks in the DPLL. Hence ensuring that 6.48 MHz output clocks, and above, are in sync with the DPLL even though only a 77.76 MHz clock drives the APLL.					
3	Test Control Leave unchanged or set to 0	0	-					
2	8k Edge Polarity When lock 8k mode is selected for the current input reference source, this bit allows the system to lock on either the rising or the falling edge of the input clock.	0 1	Lock to falling clock edge. Lock to rising clock edge.					
1	Test Control Leave unchanged or set to zero	0	-					
0	Test Control Leave unchanged or set to zero	0	-					

### Address (hex): 05

<b>Register Name</b>	<i>sts_interrupts</i>			<b>Description</b>	(R/W) Bits [7:0] of the interrupt status register.	<b>Default Value</b>	1111 1111
<b>Bit 7</b>	<b>Bit 6</b>	<b>Bit 5</b>	<b>Bit 4</b>	<b>Bit 3</b>	<b>Bit 2</b>	<b>Bit 1</b>	<b>Bit 0</b>
<i>SEC3 valid change</i>				<i>SEC2 valid change</i>	<i>SEC1 valid change</i>		
<b>Bit No.</b>	<b>Description</b>			<b>Bit Value</b>	<b>Value Description</b>		
7	<i>SEC3 valid change</i> Interrupt indicating that input SEC3 has become valid (if it was invalid), or invalid (if it was valid). Latched until reset by software writing a 1 to this bit.			0 1	Input SEC3 has not changed status (valid/invalid). Input SEC3 has changed status (valid/invalid). Writing 1 resets the input to 0.		
[6:4]	Not used.			-	-		
3	<i>SEC2 valid change</i> Interrupt indicating that input SEC2 has become valid (if it was invalid), or invalid (if it was valid). Latched until reset by software writing a 1 to this bit.			0 1	Input SEC2 has not changed status (valid/invalid). Input SEC2 has changed status (valid/invalid). Writing 1 resets the input to 0.		
2	<i>SEC1 valid change</i> Interrupt indicating that input SEC1 has become valid (if it was invalid), or invalid (if it was valid). Latched until reset by software writing a 1 to this bit.			0 1	Input SEC1 has not changed status (valid/invalid). Input SEC1 has changed status (valid/invalid). Writing 1 resets the input to 0.		
[1:0]	Not used.			-	-		

### Address (hex): 06

<b>Register Name</b>	<i>sts_interrupts</i>			<b>Description</b>	(R/W) bits [15:8] of the interrupt status register.	<b>Default Value</b>	0111 1111
<b>Bit 7</b>	<b>Bit 6</b>	<b>Bit 5</b>	<b>Bit 4</b>	<b>Bit 3</b>	<b>Bit 2</b>	<b>Bit 1</b>	<b>Bit 0</b>
<i>operating_mode</i>	<i>main_ref_failed</i>						<i>SEC4 valid change</i>
<b>Bit No.</b>	<b>Description</b>			<b>Bit Value</b>	<b>Value Description</b>		
7	<i>operating_mode</i> Interrupt indicating that the operating mode has changed. Latched until reset by software writing a 1 to this bit.			0 1	Operating mode has not changed. Operating mode has changed. Writing 1 resets the input to 0.		
6	<i>main_ref_failed</i> Interrupt indicating that input to the TO DPLL has failed. This interrupt will be raised after 2 missing input cycles. This is much quicker than waiting for the input to become invalid. This input is not generated in <i>Free-run</i> or <i>Holdover</i> modes. Latched until reset by software writing a 1 to this bit.			0 1	Input to the TO DPLL is valid. Input to the TO DPLL has failed. Writing 1 resets the input to 0.		

### Address (hex): 06 (cont...)

<b>Register Name</b>	<i>sts_interrupts</i>		<b>Description</b>	(R/W) bits [15:8] of the interrupt status register.		<b>Default Value</b>	0111 1111
<b>Bit 7</b>	<b>Bit 6</b>	<b>Bit 5</b>	<b>Bit 4</b>	<b>Bit 3</b>	<b>Bit 2</b>	<b>Bit 1</b>	<b>Bit 0</b>
<i>operating_mode</i>	<i>main_ref_failed</i>						<i>SEC4 valid change</i>
<b>Bit No.</b>	<b>Description</b>		<b>Bit Value</b>	<b>Value Description</b>			
[5:1]	Not used.		-	-			
0	<i>SEC4 valid change</i> Interrupt indicating that input SEC4 has become valid (if it was invalid), or invalid (if it was valid). Latched until reset by software writing a 1 to this bit.		0	Input SEC4 has not changed status (valid/invalid).			
			1	Input SEC4 has changed status (valid/invalid). Writing 1 resets the input to 0.			

### Address (hex): 07

<b>Register Name</b>	<i>sts_current_DPLL_frequency</i> [18:16]		<b>Description</b>	(RO) Bits [18:16] of the current DPLL frequency.		<b>Default Value</b>	0000 0000
<b>Bit 7</b>	<b>Bit 6</b>	<b>Bit 5</b>	<b>Bit 4</b>	<b>Bit 3</b>	<b>Bit 2</b>	<b>Bit 1</b>	<b>Bit 0</b>
						<i>sts_current_DPLL_frequency</i> [18:16]	
<b>Bit No.</b>	<b>Description</b>		<b>Bit Value</b>	<b>Value Description</b>			
[7:3]	Not used.		-	-			
[2:0]	<i>sts_current_DPLL_frequency</i> [18:16] When Bit 4 ( <i>T4_TO_select</i> ) of Reg. 4B ( <i>cnfg_registers_source_select</i> ) = 0 the frequency for the T0 path is reported. When this Bit 4 = 1 the frequency for the T4 path is reported.		-	See register description of <i>sts_current_DPLL_frequency</i> at address 0D hex.			

### Address (hex): 08

<b>Register Name</b>	<i>sts_interrupts</i>		<b>Description</b>	(R/W) Bits [23:16] of the interrupt status register.		<b>Default Value</b>	0101 0000
<b>Bit 7</b>	<b>Bit 6</b>	<b>Bit 5</b>	<b>Bit 4</b>	<b>Bit 3</b>	<b>Bit 2</b>	<b>Bit 1</b>	<b>Bit 0</b>
	<i>T4_status</i>						
<b>Bit No.</b>	<b>Description</b>		<b>Bit Value</b>	<b>Value Description</b>			
7	Not used.		-	-			



**Address (hex): 08 (cont...)**

<b>Register Name</b>	<i>sts_interrupts</i>		<b>Description</b>	(R/W) Bits [23:16] of the interrupt status register.		<b>Default Value</b>	0101 0000
<b>Bit 7</b>	<b>Bit 6</b>	<b>Bit 5</b>	<b>Bit 4</b>	<b>Bit 3</b>	<b>Bit 2</b>	<b>Bit 1</b>	<b>Bit 0</b>
	<i>T4_status</i>						
<b>Bit No.</b>	<b>Description</b>		<b>Bit Value</b>	<b>Value Description</b>			
6	<i>T4_status</i> Interrupt indicating that the T4 DPLL has lost lock (if it was locked) or gained lock (if it was not locked). Latched until reset by software writing a 1 to this bit.		0 1	Input to the T4 DPLL has not changed. Input to the T4 DPLL has lost/gained lock. Writing 1 resets the input to 0.			
[5:0]	Not used.		-	-			

**Address (hex): 09**

<b>Register Name</b>	<i>sts_operating</i>		<b>Description</b>	(RO) Current operating state of the device's internal state machine.		<b>Default Value</b>	0100 0001
<b>Bit 7</b>	<b>Bit 6</b>	<b>Bit 5</b>	<b>Bit 4</b>	<b>Bit 3</b>	<b>Bit 2</b>	<b>Bit 1</b>	<b>Bit 0</b>
	<i>T4_DPLL_Lock</i>	<i>TO_DPLL_freq_soft_alarm</i>	<i>T4_DPLL_freq_soft_alarm</i>		<i>TO_DPLL_operating_mode</i>		
<b>Bit No.</b>	<b>Description</b>		<b>Bit Value</b>	<b>Value Description</b>			
7	Not used.		-	-			

Address (hex): **09** (cont...)

<b>Register Name</b>	<i>sts_operating</i>			<b>Description</b>	(RO) Current operating state of the device's internal state machine.	<b>Default Value</b>	0100 0001
<b>Bit 7</b>	<b>Bit 6</b>	<b>Bit 5</b>	<b>Bit 4</b>	<b>Bit 3</b>	<b>Bit 2</b>	<b>Bit 1</b>	<b>Bit 0</b>
	<i>T4_DPLL_Lock</i>	<i>TO_DPLL_freq_soft_alarm</i>	<i>T4_DPLL_freq_soft_alarm</i>		<i>TO_DPLL_operating_mode</i>		
<b>Bit No.</b>	<b>Description</b>			<b>Bit Value</b>	<b>Value Description</b>		
6	<p><i>T4_DPLL_Lock</i> Reports current phase lock status of the T4 DPLL. The T4 DPLL does not have the same state machine as the TO DPLL, as it does not support all the features of the TO DPLL. It can only report its state as locked or unlocked.</p> <p>The bit indicates that the T4 DPLL is locked by monitoring the T4 DPLL phase loss indicators, which potentially come from four sources. The four phase loss indicators are enabled by the same registers that enable them for the TO DPLL, as follows: the fine phase loss detector enabled by Reg. 73 Bit 7, the coarse phase loss detector enabled by Reg. 74 Bit 7, the phase loss indication from no activity on the input enabled by Reg. 73 Bit 6 and phase loss from the DPLL being at its minimum or maximum frequency limits enabled by Reg. 4D Bit 7. For the T4 DPLL lock indicator (at Reg. 09 Bit 6) the bit will latch an indication of phase lost from the coarse phase lock detector such that when an indication of phase lost (or not locked) is set it stays in that phase lost or not locked state (so Reg. 09 Bit 6 =0).</p> <p>For this bit to give a correct current reading of the T4 DPLL locked state, then the coarse phase loss detector should be temporarily disabled (set Reg. 74 Bit 7 = 0), then the T4 locked bit can be read (Reg. 09 Bit 6), then the coarse phase loss detector should be re-enabled again (set Reg. 74 Bit 7 = 1).</p> <p>Once the bit is indicating "locked" (Reg. 09 Bit 6=1), it is always a correct indication and no change to the coarse phase loss detector enable is required. If at any time any cycle slips occur that trigger the coarse phase loss detector (which monitors cycle slips) then this information is latched so that the lock bit (Reg. 09 Bit 6) will go low and stay low, indicating that a problem has occurred. It is then a requirement that the coarse phase loss detector's disable/re-enable sequence is performed during a read of the T4 locked bit, in order to get a current indication of whether the T4 DPLL is locked.</p>			0 1	T4 DPLL not phase locked to reference source. T4 DPLL phase locked to reference source.		

Address (hex): **09** (cont...)

<b>Register Name</b>	<i>sts_operating</i>			<b>Description</b>	(RO) Current operating state of the device's internal state machine.	<b>Default Value</b>	0100 0001
<b>Bit 7</b>	<b>Bit 6</b>	<b>Bit 5</b>	<b>Bit 4</b>	<b>Bit 3</b>	<b>Bit 2</b>	<b>Bit 1</b>	<b>Bit 0</b>
	<i>T4_DPLL_Lock</i>	<i>TO_DPLL_freq_soft_alarm</i>	<i>T4_DPLL_freq_soft_alarm</i>		<i>TO_DPLL_operating_mode</i>		
<b>Bit No.</b>	<b>Description</b>			<b>Bit Value</b>	<b>Value Description</b>		
5	<i>TO_DPLL_freq_soft_alarm</i> The TO DPLL has a programmable frequency limit and "soft" alarm limit. The frequency limit is the extent to which it will track a reference before limiting. The "soft" limit is the point beyond which the DPLL tracking a reference will cause an alarm. This bit reports the status of the "soft" alarm.			0	TO DPLL tracking its reference within the limits of the programmed "soft" alarm.		
				1	TO DPLL tracking its reference beyond the limits of the programmed "soft" alarm.		
4	<i>T4_DPLL_freq_soft_alarm</i> The T4 DPLL has a programmable frequency limit and "soft" alarm limit. The frequency limit is the extent to which it will track a reference before limiting. The "soft" limit is the point beyond which the DPLL tracking a reference will cause an alarm. This bit reports the status of the "soft" alarm.			0	T4 DPLL tracking its reference within the limits of the programmed "soft" alarm.		
				1	T4 DPLL tracking its reference beyond the limits of the programmed "soft" alarm.		
3	Not used.			-	-		
[2:0]	<i>TO_DPLL_operating_mode</i> This field is used to report the state of the internal finite state machine controlling the TO DPLL.			000	Not used.		
				001	Free Run.		
				010	Holdover.		
				011	Not used.		
				100	Locked.		
				101	Pre-locked2.		
				110	Pre-locked.		
				111	Phase Lost.		

Address (hex): **0A**

Register Name	<i>sts_priority_table</i>	Description	(RO) Bits [7:0] of the validated priority table.				Default Value	0000 0000
Bit 7	Bit 6	Bit 5	Bit 4	Bit 3	Bit 2	Bit 1	Bit 0	
<i>Highest priority validated source</i>				<i>Currently selected source</i>				
Bit No.	Description	Bit Value	Value Description					
[7:4]	<i>Highest priority validated source</i> Reports the input channel number of the highest priority validated source.  When Bit 4 ( <i>T4_TO_select</i> ) of Reg. 4B ( <i>cnfg_registers_source_select</i> ) = 0 the highest priority validated source for the T0 path is reported. When this Bit 4 = 1 the highest priority validated source for the T4 path is reported.	0000 0011 0100 1000 1001	No valid source available. Input SEC1 is the highest priority valid source. Input SEC2 is the highest priority valid source. Input SEC3 is the highest priority valid source. Input SEC4 is the highest priority valid source.					
[3:0]	<i>Currently selected source</i> Reports the input channel number of the currently selected source. When in Non-revertive mode, this is not necessarily the same as the highest priority validated source.  When Bit 4 ( <i>T4_TO_select</i> ) of Reg. 4B ( <i>cnfg_registers_source_select</i> ) = 0 the currently selected source for the T0 path is reported. When this Bit 4 = 1 the currently selected source for the T4 path is reported. The T4 path does not have a Non-revertive mode so this will always be the same as the highest priority validated source.	0000 0011 0100 1000 1001 All other values	No source currently selected. Input SEC1 is the currently selected source. Input SEC2 is the currently selected source. Input SEC3 is the currently selected source. Input SEC4 is the currently selected source. Not used.					

### Address (hex): 0B

Register Name	<i>sts_priority_table</i>	Description	(RO) Bits [15:8] of the validated priority table.	Default Value	0000 0000		
Bit 7	Bit 6	Bit 5	Bit 4	Bit 3	Bit 2	Bit 1	Bit 0
<i>3<sup>rd</sup> highest priority validated source</i>				<i>2<sup>nd</sup> highest priority validated source</i>			
Bit No.	Description	Bit Value	Value Description				
[7:4]	<i>3<sup>rd</sup> highest priority validated source</i> Reports the input channel number of the 3 <sup>rd</sup> highest priority validated source.  When Bit 4 ( <i>T4_TO_select</i> ) of Reg. 4B ( <i>cnfg_registers_source_select</i> ) = 0 the 3 <sup>rd</sup> highest priority validated source for the TO path is reported. When this Bit 4 = 1 the value will always be zero as the T4 path does not maintain the 3 <sup>rd</sup> highest priority validated source.	0000 0011 0100 1000 1001 All other values	No source currently selected. Input SEC1 is the currently selected source. Input SEC2 is the currently selected source. Input SEC3 is the currently selected source. Input SEC4 is the currently selected source. Not used.				
[3:0]	<i>2<sup>nd</sup> highest priority validated</i> Reports the input channel number of the 2 <sup>nd</sup> highest priority validated source. When Bit 4 ( <i>T4_TO_select</i> ) of Reg. 4B ( <i>cnfg_registers_source_select</i> ) = 0 the 2 <sup>nd</sup> highest priority validated source for the TO path is reported. When this Bit 4 = 1 the 2 <sup>nd</sup> highest priority validated source for the T4 path is reported.	0000 0011 0100 1000 1001 All other values	No source currently selected. Input SEC1 is the currently selected source. Input SEC2 is the currently selected source. Input SEC3 is the currently selected source. Input SEC4 is the currently selected source. Not used.				

### Address (hex): 0C

Register Name	<i>sts_current_DPLL_frequency</i> [7:0]	Description	(RO) Bits [7:0] of the current DPLL frequency.	Default Value	0000 0000		
Bit 7	Bit 6	Bit 5	Bit 4	Bit 3	Bit 2	Bit 1	Bit 0
<i>Bits [7:0] of sts_current_DPLL_frequency</i>							
Bit No.	Description	Bit Value	Value Description				
[7:0]	<i>Bits [7:0] of sts_current_DPLL_frequency</i>  When Bit 4 ( <i>T4_TO_select</i> ) of Reg. 4B ( <i>cnfg_registers_source_select</i> ) = 0 the frequency for the TO path is reported. When this Bit 4 = 1 the frequency for the T4 path is reported.	-	See register description of <i>sts_current_DPLL_frequency</i> at address 0D hex.				

### Address (hex): 0D

<b>Register Name</b>	<i>sts_current_DPLL_frequency</i> [15:8]	<b>Description</b>	(RO) Bits [15:8] of the current DPLL frequency.	<b>Default Value</b>	0000 0000		
<b>Bit 7</b>	<b>Bit 6</b>	<b>Bit 5</b>	<b>Bit 4</b>	<b>Bit 3</b>	<b>Bit 2</b>	<b>Bit 1</b>	<b>Bit 0</b>
<i>sts_current_DPLL_frequency</i> [15:8]							
<b>Bit No.</b>	<b>Description</b>	<b>Bit Value</b>	<b>Value Description</b>				
[7:0]	<p><i>sts_current_DPLL_frequency</i>[15:8] This value in this register is combined with the value in Reg. 0C and Reg. 07 to represent the current frequency offset of the DPLL.</p> <p>When Bit 4 (<i>T4_TO_select</i>) of Reg. 4B (<i>cnfg_registers_source_select</i>) = 0 the frequency for the T0 path is reported. When this Bit 4 = 1 the frequency for the T4 path is reported.</p>	-	<p>In order to calculate the ppm offset of the DPLL with respect to the crystal oscillator frequency, the value in Reg. 07, Reg. 0D and Reg. 0C need to be concatenated. This value is a 2's complement signed integer. The value multiplied by 0.0003068 dec. will give the value in ppm offset with respect to the XO frequency, allowing for any crystal calibration that has been performed, via <i>cnfg_nominal_frequency</i>, Reg. 3C and 3D. The value is actually the DPLL integral path value so it can be viewed as an average frequency, where the rate of change is related to the DPLL bandwidth. If bit 3 of Reg. 3B is <i>High</i> then this value will freeze if the DPLL has been pulled to its min. or max. frequency.</p>				

### Address (hex): 0E

<b>Register Name</b>	<i>sts_sources_valid</i>	<b>Description</b>	(RO) 8 least significant bits of the <i>sts_sources_valid</i> register.	<b>Default Value</b>	0000 0000		
<b>Bit 7</b>	<b>Bit 6</b>	<b>Bit 5</b>	<b>Bit 4</b>	<b>Bit 3</b>	<b>Bit 2</b>	<b>Bit 1</b>	<b>Bit 0</b>
SEC3				SEC2	SEC1		
<b>Bit No.</b>	<b>Description</b>	<b>Bit Value</b>	<b>Value Description</b>				
7	<p>SEC3 Bit indicating if SEC3 is valid. The input is valid if either it has no outstanding alarms, or it only has a soft frequency alarm.</p>	0 1	<p>Input SEC3 is invalid. Input SEC3 is valid.</p>				
[6:4]	Not used.	-	-				
3	<p>SEC2 Bit indicating if SEC2 is valid. The input is valid if either it has no outstanding alarms, or it only has a soft frequency alarm.</p>	0 1	<p>Input SEC2 is invalid. Input SEC2 is valid.</p>				
2	<p>SEC1 Bit indicating if SEC1 is valid. The input is valid if either it has no outstanding alarms, or it only has a soft frequency alarm.</p>	0 1	<p>Input SEC1 is invalid. Input SEC1 is valid.</p>				
[1:0]	Not used.	-	-				

Address (hex): **0F**

<b>Register Name</b>	<i>sts_sources_valid</i>		<b>Description</b>	(RO) 8 most significant bits of the <i>sts_sources_valid</i> register.		<b>Default Value</b>	0000 0000
<b>Bit 7</b>	<b>Bit 6</b>	<b>Bit 5</b>	<b>Bit 4</b>	<b>Bit 3</b>	<b>Bit 2</b>	<b>Bit 1</b>	<b>Bit 0</b>
							<i>SEC4</i>
<b>Bit No.</b>	<b>Description</b>		<b>Bit Value</b>	<b>Value Description</b>			
[7:1]	Not used.		-	-			
0	<i>SEC4</i> Bit indicating if <i>SEC4</i> is valid. The input is valid if either it has no outstanding alarms, or it only has a soft frequency alarm.		0	Input <i>SEC4</i> is invalid.			
			1	Input <i>SEC4</i> is valid.			

Address (hex): **11**

<b>Register Name</b>	<i>sts_reference_sources</i> <i>Inputs SEC1 &amp; SEC2</i>		<b>Description</b>	(RO except for test when R/W) Reports any alarms active on inputs.		<b>Default Value</b>	0110 0110
<b>Bit 7</b>	<b>Bit 6</b>	<b>Bit 5</b>	<b>Bit 4</b>	<b>Bit 3</b>	<b>Bit 2</b>	<b>Bit 1</b>	<b>Bit 0</b>
<i>Address 11: Status of SEC2 Input</i> <i>Address 13: Status of SEC3 Input</i>				<i>Address 11: Status of SEC1 Input</i> <i>Address 14: Status of SEC4 Input</i>			
<i>Out-of-band alarm (soft)</i>	<i>Out-of-band alarm (hard)</i>	<i>No activity alarm</i>	<i>Phase lock alarm</i>	<i>Out-of-band alarm (soft)</i>	<i>Out-of band alarm (hard)</i>	<i>No activity alarm</i>	<i>Phase lock alarm</i>
<b>Bit No.</b>	<b>Description</b>		<b>Bit Value</b>	<b>Value Description</b>			
7 & 3	<i>Out-of-band alarm (soft)</i> Soft out-of-band alarm bit for input. A “soft” alarm will not invalidate an input.		0	No alarm.			
			1	Alarm armed. Alarm thresholds set by Reg. 49 bits [7:4], or by Reg. 4A bits 7:4 if the input is currently selected.			
6 & 2	<i>Out-of-band alarm (hard)</i> Hard out-of-band alarm bit for input. A “hard” alarm will invalidate an input.		0	No alarm.			
			1	Alarm armed. Alarm thresholds set by Reg. 49 bits [3:0], or by Reg. 4A bits [3:0] if the input is currently selected.			
5 & 1	<i>No activity alarm</i> Alarm indication from the activity monitors.		0	No alarm.			
			1	Input has an active no activity alarm.			
4 & 0	<i>Phase lock alarm</i> If the DPLL can not indicate that it is phase locked onto the current source within 100 seconds this alarm will be raised.		0	No alarm.			
			1	Phase lock alarm.			

**Address (hex): 13** As Reg. 11, but for *sts\_reference\_sources*, Input SEC3 Default Value: 0110 0110

**Address (hex): 14** As Reg. 11, but for *sts\_reference\_sources*, Input SEC4 Default Value: 0110 0110

**Address (hex): 19**

Register Name	Description	(R/W)	Configures the relative priority of input sources SEC2 and SEC1.	Default Value			
<i>cnfg_ref_selection_priority</i> (SEC2 & SEC1)				*(TO) 0011 0010 *(T4) 0011 0010			
<b>Bit 7</b>	<b>Bit 6</b>	<b>Bit 5</b>	<b>Bit 4</b>	<b>Bit 3</b>	<b>Bit 2</b>	<b>Bit 1</b>	<b>Bit 0</b>
<i>cnfg_ref_selection_priority_SEC2</i>				<i>cnfg_ref_selection_priority_SEC1</i>			
Bit No.	Description	Bit Value	Value Description				
[7:4]	<i>cnfg_ref_selection_priority_SEC2</i> This 4-bit value represents the relative priority of input SEC2. The smaller the number, the higher the priority; zero disables the input. *When Bit 4 ( <i>T4_TO_select</i> ) of Reg. 4B ( <i>cnfg_registers_source_select</i> ) = 0 the priority for the TO path is configured. When this Bit 4 = 1 the priority for the T4 path is configured.	0000 0001-1111	Input SEC2 unavailable for automatic selection. Input SEC2 priority value.				
[3:0]	<i>cnfg_ref_selection_priority_SEC1</i> This 4-bit value represents the relative priority of input SEC1. The smaller the number, the higher the priority; zero disables the input. *When Bit 4 ( <i>T4_TO_select</i> ) of Reg. 4B ( <i>cnfg_registers_source_select</i> ) = 0 the priority for the TO path is configured. When this Bit 4 = 1 the priority for the T4 path is configured.	0000 0001-1111	Input SEC1 unavailable for automatic selection. Input SEC1 priority value.				



### Address (hex): 1B

<b>Register Name</b>	<i>cnfg_ref_selection_priority</i> (SEC3)	<b>Description</b>	(R/W) Configures the relative priority of input source SEC3.	<b>Default Value</b>	* (T0) 0100 0000 * (T4) 0101 0100		
<b>Bit 7</b>	<b>Bit 6</b>	<b>Bit 5</b>	<b>Bit 4</b>	<b>Bit 3</b>	<b>Bit 2</b>	<b>Bit 1</b>	<b>Bit 0</b>
<i>cnfg_ref_selection_priority_SEC3</i>							
<b>Bit No.</b>	<b>Description</b>	<b>Bit Value</b>	<b>Value Description</b>				
[7:4]	<i>cnfg_ref_selection_priority_SEC3</i> This 4-bit value represents the relative priority of input SEC3. The smaller the number, the higher the priority; zero disables the input. *When Bit 4 ( <i>T4_TO_select</i> ) of Reg. 4B ( <i>cnfg_registers_source_select</i> ) = 0 the priority for the T0 path is configured. When this Bit 4 = 1 the priority for the T4 path is configured.	0000 0001-1111	Input SEC3 unavailable for automatic selection. Input SEC3 priority value.				
[3:0]	Not used.	-	-				

### Address (hex): 1C

<b>Register Name</b>	<i>cnfg_ref_selection_priority</i> (SEC4)	<b>Description</b>	(R/W) Configures the relative priority of input source SEC4.	<b>Default Value</b>	* (T0) 0000 0101 * (T4) 0000 0000		
<b>Bit 7</b>	<b>Bit 6</b>	<b>Bit 5</b>	<b>Bit 4</b>	<b>Bit 3</b>	<b>Bit 2</b>	<b>Bit 1</b>	<b>Bit 0</b>
				<i>cnfg_ref_selection_priority_SEC4</i>			
<b>Bit No.</b>	<b>Description</b>	<b>Bit Value</b>	<b>Value Description</b>				
[7:4]	Not used.	-	-				
[3:0]	<i>cnfg_ref_selection_priority_SEC4</i> This 4 bit value represents the relative priority of input SEC4. The smaller the number, the higher the priority; zero disables the input. *When Bit 4 ( <i>T4_TO_select</i> ) of Reg. 4B ( <i>cnfg_registers_source_select</i> ) = 0 the priority for the T0 path is configured. When this Bit 4 = 1 the priority for the T4 path is configured.	0000 0001-1111	Input SEC4 unavailable for automatic selection. Input SEC4 priority value.				

### Address (hex): 22

Use <n> = 1

Register Name	Description		Default Value
<i>cnfg_ref_source_frequency</i> SEC<n>, where for Reg 22, <n> = 1	(R/W) Configuration of the frequency and input monitoring for input SEC<n>.		0000 0000
<b>Bit 7</b>	<b>Bit 6</b>	<b>Bit 5</b>	<b>Bit 4</b>
<i>divn_SEC&lt;n&gt;</i>	<i>lock8k_SEC&lt;n&gt;</i>	<i>bucket_id_SEC&lt;n&gt;</i>	<i>reference_source_frequency_SEC&lt;n&gt;</i>
Bit No.	Description	Bit Value	Value Description
7	<i>divn_SEC&lt;n&gt;</i> This bit selects whether or not input SEC<n> is divided in the programmable pre-divider prior to being input to the DPLL and frequency monitor- see Reg. 46 and Reg. 47 ( <i>cnfg_freq_divn</i> ).	0 1	Input SEC<n> fed directly to DPLL and monitor. Input SEC<n> fed to DPLL and monitor via pre-divider.
6	<i>lock8k_SEC&lt;n&gt;</i> This bit selects whether or not input SEC<n> is divided in the preset pre-divider prior to being input to the DPLL. This results in the DPLL locking to the reference after it has been divided to 8 kHz. This bit is ignored when <i>divn_SEC&lt;n&gt;</i> is set (bit =1).	0 1	Input SEC<n> fed directly to DPLL. Input SEC<n> fed to DPLL via preset pre-divider.
[5:4]	<i>bucket_id_SEC&lt;n&gt;</i> Every input has its own Leaky Bucket used for activity monitoring. There are four possible configurations for each Leaky Bucket- see Reg. 50 to Reg. 5F. This 2-bit field selects the configuration used for input SEC<n>.	00 01 10 11	Input SEC<n> activity monitor uses Leaky Bucket Configuration 0. Input SEC<n> activity monitor uses Leaky Bucket Configuration 1. Input SEC<n> activity monitor uses Leaky Bucket Configuration 2. Input SEC<n> activity monitor uses Leaky Bucket Configuration 3.
[3:0]	<i>reference_source_frequency_SEC&lt;n&gt;</i> Programs the frequency of the reference source connected to input SEC<n>. If <i>divn_SEC&lt;n&gt;</i> is set, then this value should be set to 0000 (8 kHz).	0000 0001 0010 0011 0100 0101 0110 0111 1000 1001 1010 1011-1111	8 kHz. 1544/2048 kHz (dependant on Bit 2 ( <i>ip_sonsdhb</i> ) in Reg. 34). 6.48 MHz. 19.44 MHz. 25.92 MHz. 38.88 MHz. 51.84 MHz. 77.76 MHz. Not used. 2 kHz. 4 kHz. Not used.

### Address (hex): 23

Use description for Reg. 22, but use <n> = 2

Default Value: 0000 0000

### Address (hex): 27

Use description for Reg. 22, but use <n> = 3

Default Value: 0000 0011

### Address (hex): 28

Use description for Reg. 22, but use <n> = 4

Default Value: 0000 0011

### Address (hex): 32

<b>Register Name</b>	<i>cnfg_operating_mode</i>	<b>Description</b>	(R/W) Register to force the state of the TO DPLL controlling state machine.		<b>Default Value</b>	0000 0000	
<b>Bit 7</b>	<b>Bit 6</b>	<b>Bit 5</b>	<b>Bit 4</b>	<b>Bit 3</b>	<b>Bit 2</b>	<b>Bit 1</b>	<b>Bit 0</b>
					<i>TO_DPLL_operating_mode</i>		
<b>Bit No.</b>	<b>Description</b>	<b>Bit Value</b>	<b>Value Description</b>				
[7:3]	Not used.	-	-				
[2:0]	<i>TO_DPLL_operating_mode</i> This field is used to control the state of the internal finite state machine controlling the TO DPLL. A value of zero is used to allow the finite state machine to control itself. Any other value will force the state machine to jump into that state. Care should be taken when forcing the state machine. Whilst it is forced, the internal monitoring functions cannot affect the internal state machine, therefore, the user is responsible for all monitoring and control functions required to achieve the desired functionality.	000 001 010 011 100 101 110 111	Automatic (internal state machine controlled). Free Run. Holdover. Not used. Locked. Pre-locked2. Pre-locked. Phase Lost.				

### Address (hex): 33

<b>Register Name</b>	<i>force_select_reference_source</i>	<b>Description</b>	(R/W) Register used to force the selection of a particular reference source for the TO DPLL.		<b>Default Value</b>	0000 1111	
<b>Bit 7</b>	<b>Bit 6</b>	<b>Bit 5</b>	<b>Bit 4</b>	<b>Bit 3</b>	<b>Bit 2</b>	<b>Bit 1</b>	<b>Bit 0</b>
					<i>forced_reference_source</i>		
<b>Bit No.</b>	<b>Description</b>	<b>Bit Value</b>	<b>Value Description</b>				
[7:4]	Not used.	-	-				

### Address (hex): 33 (cont...)

<b>Register Name</b>	<i>force_select_reference_source</i>	<b>Description</b>	(R/W) Register used to force the selection of a particular reference source for the TO DPLL.	<b>Default Value</b>	0000 1111		
<b>Bit 7</b>	<b>Bit 6</b>	<b>Bit 5</b>	<b>Bit 4</b>	<b>Bit 3</b>	<b>Bit 2</b>	<b>Bit 1</b>	<b>Bit 0</b>
				<i>forced_reference_source</i>			
<b>Bit No.</b>	<b>Description</b>	<b>Bit Value</b>	<b>Value Description</b>				
[3:0]	<i>forced_reference_source</i> Value representing the source to be selected by the TO DPLL. Value of 0 hex will leave the selection to the automatic control mechanism within the device. Using this mechanism will bypass all the monitoring functions assuming the selected input to be valid. If the device is not in state "Locked" then it will progress to state locked in the usual manner. If the input fails, the device will not change state to Holdover, as it is not allowed to disqualify the source.  The effect of this register is simply to raise the priority of the selected input reference to "1" (highest). To ensure selection of the programmed input reference under all circumstances, Revertive mode should be enabled (Reg. 34 Bit 0 set to "1").	0000 0011 0100 1000 1001 1111 All other values	Automatic state machine source selection TO DPLL forced to select input SEC1. TO DPLL forced to select input SEC2. TO DPLL forced to select input SEC3. TO DPLL forced to select input SEC4. Automatic. Not used.				

### Address (hex): 34

<b>Register Name</b>	<i>cnfg_input_mode</i>	<b>Description</b>	(R/W) Register controlling various input modes of the device.	<b>Default Value</b>	1100 1010		
<b>Bit 7</b>	<b>Bit 6</b>	<b>Bit 5</b>	<b>Bit 4</b>	<b>Bit 3</b>	<b>Bit 2</b>	<b>Bit 1</b>	<b>Bit 0</b>
Set to 0	<i>phalarm_time-out</i>	<i>XO_edge</i>	<i>man_holdover</i>	<i>extsync_en</i>	<i>ip_sonsdhb</i>		<i>reversion_mode</i>
<b>Bit No.</b>	<b>Description</b>	<b>Bit Value</b>	<b>Value Description</b>				
7	Set to 0.	0	Set to 0.				
6	<i>phalarm_timeout</i> Bit to enable the automatic timeout facility on phase alarms. When enabled, any source with a phase alarm set will have its phase alarm cancelled after 128 seconds.	0 1	Phase alarms on sources only cancelled by software. Phase alarms on sources automatically time out.				
5	<i>XO_edge</i> If the 12.800 MHz oscillator module connected to REFCLK has one edge faster than the other, then for jitter performance reasons, the faster edge should be selected. This bit allows either the rising edge or the falling edge to be selected.	0 1	Device uses the rising edge of the external oscillator. Device uses the falling edge of the external oscillator.				

**Address (hex): 34 (cont...)**

<b>Register Name</b>	<i>cnfg_input_mode</i>		<b>Description</b>	(R/W) Register controlling various input modes of the device.		<b>Default Value</b>	1100 1010
<b>Bit 7</b>	<b>Bit 6</b>	<b>Bit 5</b>	<b>Bit 4</b>	<b>Bit 3</b>	<b>Bit 2</b>	<b>Bit 1</b>	<b>Bit 0</b>
Set to 0	<i>phalarm_time-out</i>	<i>XO_edge</i>	<i>man_holdover</i>	<i>extsync_en</i>	<i>ip_sonsdhb</i>		<i>reversion_mode</i>
<b>Bit No.</b>	<b>Description</b>	<b>Bit Value</b>	<b>Value Description</b>				
4	<i>man_holdover</i> Bit to select whether or not the Holdover frequency is taken directly from Reg. 3E/Reg. 3F/Reg. 40 ( <i>cnfg_holdover_frequency</i> ). If this bit is set then it overrides any other Holdover control bits.	0 1	Holdover frequency is determined automatically. Holdover frequency is taken from <i>cnfg_holdover_frequency</i> register.				
3	<i>extsync_en</i> Bit to select whether or not the TO DPLL will look for a reference Sync pulse on the SYNC2K input pin. Even though this bit may enable the external Sync reference, it may be disabled according to <i>auto_extsync_en</i> .	0 1	No external Sync signal- SYNC2K pin ignored. External Sync derived from SYNC2K pin according to <i>auto_extsync_en</i> .				
2	<i>ip_sonsdhb</i> Bit to configure input frequencies to be either SONET or SDH derived. This applies only to selections of 0001 (bin) in the <i>cnfg_ref_source_frequency</i> registers when the input frequency is either 1544 kHz or 2048 kHz.	0 1	SDH- inputs set to 0001 expected to be 2048 kHz. SONET- inputs set to 0001 expected to be 1544 kHz.				
1	Not used.	-	-				
0	<i>reversion_mode</i> Bit to select Revertive/Non-revertive mode. When in Non-revertive mode, the device will not automatically switch to a higher priority source, unless the current source fails. When in Revertive mode the device will always select the highest priority source.	0 1	Non-revertive mode. Revertive mode.				

**Address (hex): 35**

<b>Register Name</b>	<i>cnfg_T4_path</i>			<b>Description</b>	Register to configure the inputs and other features in the T4 path.	<b>Default Value</b>	0100 0000
<b>Bit 7</b>	<b>Bit 6</b>	<b>Bit 5</b>	<b>Bit 4</b>	<b>Bit 3</b>	<b>Bit 2</b>	<b>Bit 1</b>	<b>Bit 0</b>
<i>lock_T4_to_T0</i>	<i>T4_dig_feed-back</i>				<i>T4_forced_reference_source</i>		
<b>Bit No.</b>	<b>Description</b>			<b>Bit Value</b>	<b>Value Description</b>		
7	<i>lock_T4_to_T0</i> Bit selects either the T4 direct inputs, or T0 DPLL as the input of the T4 path. This allows the T4 DPLL to be used to produce different sets of frequencies to the T0 DPLL but still maintain lock.			0 1	T4 path locks independently from the T0 path. T4 DPLL locks to the output of the T0 DPLL.		
6	<i>T4_dig_feedback</i> Bit to select digital feedback mode for the T4 DPLL.			0 1	T4 DPLL in analog feedback mode. T4 DPLL in digital feedback mode.		
[5:4]	Not used.			-	-		
[3:0]	<i>T4_forced_reference_source</i> This field can be used to force the T4 DPLL to select a particular input. A value of zero in this field allows the T4 input to be selected automatically via the priority and input monitoring functions.			0000 0011 0100 1000 1001 All other values	T4 DPLL automatic source selection. T4 DPLL forced to select input SEC1. T4 DPLL forced to select input SEC2. T4 DPLL forced to select input SEC3. T4 DPLL forced to select input SEC4. Not used.		

**Address (hex): 38**

<b>Register Name</b>	<i>cnfg_dig_outputs_sonsdh</i>			<b>Description</b>	Configures <i>Digital1</i> and <i>Digital2</i> output frequencies to be SONET or SDH compatible frequencies.	<b>Default Value</b>	0000 1101*
<b>Bit 7</b>	<b>Bit 6</b>	<b>Bit 5</b>	<b>Bit 4</b>	<b>Bit 3</b>	<b>Bit 2</b>	<b>Bit 1</b>	<b>Bit 0</b>
	<i>dig2_sonsdh</i>	<i>dig1_sonsdh</i>					
<b>Bit No.</b>	<b>Description</b>			<b>Bit Value</b>	<b>Value Description</b>		
7	Not used.			-	-		
6	<i>dig2_sonsdh</i> Selects whether the frequencies generated by the <i>Digital2</i> frequency generator are SONET derived or SDH. *Default value of this bit is set by the SONSDHB pin at power-up.			1 0	<i>Digital2</i> can be selected from 1544/3088/6176/12352 kHz. <i>Digital2</i> can be selected from 2048/4096/8192/16384 kHz.		

### Address (hex): 38 (cont...)

<b>Register Name</b>	<i>cnfg_dig_outputs_sonsdh</i>		<b>Description</b>	Configures <i>Digital1</i> and <i>Digital2</i> output frequencies to be SONET or SDH compatible frequencies.		<b>Default Value</b>	0000 1101*
<b>Bit 7</b>	<b>Bit 6</b>	<b>Bit 5</b>	<b>Bit 4</b>	<b>Bit 3</b>	<b>Bit 2</b>	<b>Bit 1</b>	<b>Bit 0</b>
	<i>dig2_sonsdh</i>	<i>dig1_sonsdh</i>					
<b>Bit No.</b>	<b>Description</b>		<b>Bit Value</b>	<b>Value Description</b>			
5	<i>dig1_sonsdh</i> Selects whether the frequencies generated by the <i>Digital1</i> frequency generator are SONET derived or SDH. *Default value of this bit is set by the SONSDHB pin at power-up.		1	<i>Digital1</i> can be selected from 1544/3088/6176/12352 kHz.			
			0	<i>Digital1</i> can be selected from 2048/4096/8192/16384 kHz.			
[4:0]	Not used.		-	-			

### Address (hex): 39

<b>Register Name</b>	<i>cnfg_digital_frequencies</i>		<b>Description</b>	(R/W) Configures the actual frequencies of <i>Digital1</i> & <i>Digital2</i> .		<b>Default Value</b>	0000 1000
<b>Bit 7</b>	<b>Bit 6</b>	<b>Bit 5</b>	<b>Bit 4</b>	<b>Bit 3</b>	<b>Bit 2</b>	<b>Bit 1</b>	<b>Bit 0</b>
	<i>digital2_frequency</i>	<i>digital1_frequency</i>					
<b>Bit No.</b>	<b>Description</b>		<b>Bit Value</b>	<b>Value Description</b>			
[7:6]	<i>digital2_frequency</i> Configures the frequency of <i>Digital2</i> . Whether this is SONET or SDH based is configured by Bit 6 ( <i>dig2_sonsdh</i> ) of Reg. 38.		00	<i>Digital2</i> set to 1544 kHz or 2048 kHz.			
			01	<i>Digital2</i> set to 3088 kHz or 4096 kHz.			
			10	<i>Digital2</i> set to 6176 kHz or 8192 kHz.			
			11	<i>Digital2</i> set to 12353 kHz or 16384 kHz.			
[5:4]	<i>digital1_frequency</i> Configures the frequency of <i>Digital1</i> . Whether this is SONET or SDH based is configured by Bit 5 ( <i>dig1_sonsdh</i> ) of Reg. 38.		00	<i>Digital1</i> set to 1544 kHz or 2048 kHz.			
			01	<i>Digital1</i> set to 3088 kHz or 4096 kHz.			
			10	<i>Digital1</i> set to 6176 kHz or 8192 kHz.			
			11	<i>Digital1</i> set to 12353 kHz or 16384 kHz.			
[3:0]	Not used.						

### Address (hex): 3A

<b>Register Name</b>	<i>cnfg_differential_outputs</i>	<b>Description</b>	(R/W) Configures the electrical compatibility of the differential output driver O1 to be 3 V PECL or 3 V LVDS.				<b>Default Value</b>	1100 0010
<b>Bit 7</b>	<b>Bit 6</b>	<b>Bit 5</b>	<b>Bit 4</b>	<b>Bit 3</b>	<b>Bit 2</b>	<b>Bit 1</b>	<b>Bit 0</b>	
						<i>O1_LVDS_PECL</i>		
<b>Bit No.</b>	<b>Description</b>	<b>Bit Value</b>	<b>Value Description</b>					
[7:2]	Not used.	-	-					
[1:0]	<i>O1_LVDS_PECL</i> Selection of the electrical compatibility of Output O1 between 3 V PECL and 3 V LVDS.	00	Output O1 disabled.					
		01	Output O1 3 V PECL compatible.					
		10	Output O1 3 V LVDS compatible.					
		11	Not used.					

### Address (hex): 3B

<b>Register Name</b>	<i>cnfg_auto_bw_sel</i>	<b>Description</b>	(R/W) Register to select automatic bandwidth selection for the TO DPLL path				<b>Default Value</b>	1111 1101
<b>Bit 7</b>	<b>Bit 6</b>	<b>Bit 5</b>	<b>Bit 4</b>	<b>Bit 3</b>	<b>Bit 2</b>	<b>Bit 1</b>	<b>Bit 0</b>	
<i>auto_BW_sel</i>				<i>TO_lim_int</i>				
<b>Bit No.</b>	<b>Description</b>	<b>Bit Value</b>	<b>Value Description</b>					
7	<i>auto_BW_sel</i> Bit to select locked bandwidth (Reg. 67) or acquisition bandwidth (Reg. 69) for the TO DPLL.	1	Automatically selects either locked or acquisition bandwidth as appropriate.					
		0	Always selects locked bandwidth.					
[6:4]	Not used.	-	-					
3	<i>TO_lim_int</i> When set to 1 the integral path value of the DPLL is limited or frozen when the DPLL reaches either min. or max. frequency. This can be used to minimize subsequent overshoot when the DPLL is pulling in. Note that when this happens, the reported frequency value via <i>current_DPLL_freq</i> (Reg. 0C, 0D and 07) is also frozen.	1	DPLL value frozen.					
		0	DPLL not frozen.					
[2:0]	Not used.	-	-					



### Address (hex): 3C

<b>Register Name</b>	<i>cnfg_nominal_frequency</i> [7:0]	<b>Description</b>	(R/W) Bits [7:0] of the register used to calibrate the crystal oscillator used to clock the device.	<b>Default Value</b>	1001 1001		
<b>Bit 7</b>	<b>Bit 6</b>	<b>Bit 5</b>	<b>Bit 4</b>	<b>Bit 3</b>	<b>Bit 2</b>	<b>Bit 1</b>	<b>Bit 0</b>
<i>cnfg_nominal_frequency_value</i> [7:0]							
<b>Bit No.</b>	<b>Description</b>	<b>Bit Value</b>	<b>Value Description</b>				
[7:0]	<i>cnfg_nominal_frequency_value</i> [7:0]	-	See register description of Reg. 3D ( <i>cnfg_nominal_frequency_value</i> [15:8]).				

### Address (hex): 3D

<b>Register Name</b>	<i>cnfg_nominal_frequency</i> [15:8]	<b>Description</b>	(R/W) Bits [15:8] of the register used to calibrate the crystal oscillator used to clock the device.	<b>Default Value</b>	1001 1001		
<b>Bit 7</b>	<b>Bit 6</b>	<b>Bit 5</b>	<b>Bit 4</b>	<b>Bit 3</b>	<b>Bit 2</b>	<b>Bit 1</b>	<b>Bit 0</b>
<i>cnfg_nominal_frequency_value</i> [15:8]							
<b>Bit No.</b>	<b>Description</b>	<b>Bit Value</b>	<b>Value Description</b>				
[7:0]	<i>cnfg_nominal_frequency_value</i> [15:8] This register is used in conjunction with Reg. 3C ( <i>cnfg_nominal_frequency_value</i> [7:0]) to be able to offset the frequency of the crystal oscillator by up to +514 ppm and -771 ppm. The default value represents 0 ppm offset from 12.800 MHz. This value is an unsigned integer.	-	In order to program the ppm offset of the crystal oscillator frequency, the value in Reg. 3C and Reg. 3D hex need to be concatenated. This value is an unsigned integer. The value multiplied by 0.0196229 dec. will give the value in ppm. To calculate the absolute value, the default 39321 (9999 hex) needs to be subtracted.				

### Address (hex): 3E

<b>Register Name</b>	<i>cnfg_holdover_frequency</i> [7:0]	<b>Description</b>	(R/W) Bits [7:0] of the manual Holdover frequency register.	<b>Default Value</b>	0000 0000		
<b>Bit 7</b>	<b>Bit 6</b>	<b>Bit 5</b>	<b>Bit 4</b>	<b>Bit 3</b>	<b>Bit 2</b>	<b>Bit 1</b>	<b>Bit 0</b>
<i>holdover_frequency_value</i> [7:0]							
<b>Bit No.</b>	<b>Description</b>	<b>Bit Value</b>	<b>Value Description</b>				
[7:0]	<i>holdover_frequency_value</i> [7:0]	-	See Reg. 3F ( <i>cnfg_holdover_frequency</i> ) for details.				

### Address (hex): 3F

<b>Register Name</b>	<i>cnfg_holdover_frequency</i> [15:8]	<b>Description</b>	(R/W) Bits [15:8] of the manual Holdover frequency register.	<b>Default Value</b>	0000 0000		
<b>Bit 7</b>	<b>Bit 6</b>	<b>Bit 5</b>	<b>Bit 4</b>	<b>Bit 3</b>	<b>Bit 2</b>	<b>Bit 1</b>	<b>Bit 0</b>
<i>holdover_frequency_value</i> [15:8]							
<b>Bit No.</b>	<b>Description</b>	<b>Bit Value</b>	<b>Value Description</b>				
[7:0]	<i>holdover_frequency_value</i> [15:8] This value in this register is combined with the value in Reg. 3E and Bits [2:0] of Reg. 40 to represent the programmed Holdover frequency of the TO DPLL.  This register is designed such that software can read the <i>sts_current_DPLL_frequency</i> register (Reg. 0C, Reg. 0D and Reg. 07) and filter the value. The result will then be in a suitable format to simply write back to the <i>cnfg_holdover_frequency</i> register.  This register can be programmed to read back the internally averaged Holdover frequency rather than the programmed value, see Bit 5 of Reg. 40 <i>cnfg_holdover_modes</i> .	-	In order to calculate the Holdover ppm offset of the DPLL with respect to the crystal oscillator frequency, the value in Reg. 3E and the value in Bits [2:0] of Reg. 40 need to be concatenated. This value is a 2's complement signed integer. The value multiplied by 0.0003068 dec. will give the value in ppm.				

### Address (hex): 40

<b>Register Name</b>	<i>cnfg_holdover_modes</i>	<b>Description</b>	(R/W) Register to control the Holdover modes of the TO DPLL.	<b>Default Value</b>	1000 1000		
<b>Bit 7</b>	<b>Bit 6</b>	<b>Bit 5</b>	<b>Bit 4</b>	<b>Bit 3</b>	<b>Bit 2</b>	<b>Bit 1</b>	<b>Bit 0</b>
<i>auto_averaging</i>	<i>fast_averaging</i>	<i>read_average</i>	<i>mini_holdover_mode</i>	<i>holdover_frequency_value</i> [18:16]			
<b>Bit No.</b>	<b>Description</b>	<b>Bit Value</b>	<b>Value Description</b>				
7	<i>auto_averaging</i> Bit to enable the use of the averaged frequency value during Holdover. This bit is overridden by the manual Holdover control (Bit 4, <i>man_holdover</i> , in Reg. 34).	0 1	Averaged frequency not used, Holdover frequency either manual or instantaneously frozen. Averaged frequency used, providing manual Holdover mode is not engaged.				
6	<i>fast_averaging</i> Bit to control the rate of averaging of the Holdover frequency. Fast averaging gives a -3db response point of approximately 8 minutes. Slow averaging give a -3db response point of approximately 110 minutes.	0 1	Slow Holdover frequency averaging enabled. Fast Holdover frequency averaging enabled.				

Address (hex): **40** (cont...)

Register Name	<i>cnfg_holdover_modes</i>		Description	(R/W) Register to control the Holdover modes of the TO DPLL.		Default Value	1000 1000	
Bit 7	Bit 6	Bit 5	Bit 4	Bit 3	Bit 2	Bit 1	Bit 0	
<i>auto_averaging</i>	<i>fast_averaging</i>	<i>read_average</i>	<i>mini_holdover_mode</i>		<i>holdover_frequency_value [18:16]</i>			
Bit No.	Description	Bit Value	Value Description					
5	<i>read_average</i> Bit to control whether the value read from the <i>holdover_frequency_value</i> register is the value written to that register, or the averaged Holdover frequency. This allows software to use the internal averager as part of the Holdover algorithm, but use manual Holdover mode plus software to enhance the performance.	0 1	Value read from <i>holdover_frequency_value</i> is the value written to it. Value read from a <i>holdover_frequency_value</i> is either the fast or slow averaged frequency as determined by <i>fast_averaging</i> .					
[4:3]	<i>mini_holdover_mode</i> Mini-holdover is a term used to describe the state of the DPLL when it is in locked mode, but it has temporarily lost its input. This may be a temporary state, or last for many seconds whilst an input is checked for inactivity. The DPLL behaves exactly as in Holdover, and the frequency can be determined in the same selection of ways (instantaneously, fast averaged or slow averaged).	00 01 10 11	Mini-holdover frequency determined in the same way as for full Holdover mode. Mini-holdover frequency frozen instantaneously. Mini-holdover frequency taken from fast averager. Mini-holdover frequency taken from slow averager.					
[2:0]	<i>holdover_frequency_value [18:16]</i>	-	See Reg. 3F ( <i>cnfg_holdover_frequency</i> ) for details.					

**Address (hex): 41**

<b>Register Name</b>	<i>cnfg_DPLL_freq_limit</i> [7:0]	<b>Description</b>	(R/W) Bits [7:0] of the DPLL frequency limit register.	<b>Default Value</b>	0111 0110		
<b>Bit 7</b>	<b>Bit 6</b>	<b>Bit 5</b>	<b>Bit 4</b>	<b>Bit 3</b>	<b>Bit 2</b>	<b>Bit 1</b>	<b>Bit 0</b>
<i>DPLL_freq_limit_value</i> [7:0]							
<b>Bit No.</b>	<b>Description</b>	<b>Bit Value</b>	<b>Value Description</b>				
[7:0]	<i>DPLL_freq_limit_value</i> [7:0] This register defines the extent of frequency offset to which either the T0 or the T4 DPLL will track a source before limiting- i.e. it represents the pull-in range of the DPLLs. The offset of the device is determined by the frequency offset of the DPLL when compared to the offset of the external crystal oscillator clocking the device. If the oscillator is calibrated using <i>cnfg_nominal_frequency</i> Reg. 3C and 3D, then this calibration is automatically taken into account. The DPLL frequency limit limits the offset of the DPLL when compared to the calibrated oscillator frequency.	-	In order to calculate the frequency limit in ppm, Bits [1:0] of Reg. 42 and Bits [7:0] of Reg. 41 need to be concatenated. This value is a unsigned integer and represents limit <i>both</i> positive and negative in ppm. The value multiplied by 0.078 will give the value in ppm.				

**Address (hex): 42**

<b>Register Name</b>	<i>cnfg_DPLL_freq_limit</i> [9:8]	<b>Description</b>	(R/W) Bits [9:8] of the DPLL frequency limit register.	<b>Default Value</b>	0000 0000		
<b>Bit 7</b>	<b>Bit 6</b>	<b>Bit 5</b>	<b>Bit 4</b>	<b>Bit 3</b>	<b>Bit 2</b>	<b>Bit 1</b>	<b>Bit 0</b>
						<i>DPLL_freq_limit_value</i> [9:8]	
<b>Bit No.</b>	<b>Description</b>	<b>Bit Value</b>	<b>Value Description</b>				
[7:2]	Not used.	-	-				
[1:0]	<i>DPLL_freq_limit_value</i> [9:8]	-	See Reg. 41 ( <i>cnfg_DPLL_freq_limit</i> ) for details.				

### Address (hex): 43

<b>Register Name</b>	<i>cnfg_interrupt_mask</i> [7:0]	<b>Description</b>	(R/W) Bits [7:0] of the interrupt mask register.	<b>Default Value</b>	0000 0000		
<b>Bit 7</b>	<b>Bit 6</b>	<b>Bit 5</b>	<b>Bit 4</b>	<b>Bit 3</b>	<b>Bit 2</b>	<b>Bit 1</b>	<b>Bit 0</b>
<i>SEC3 interrupt not masked</i>				<i>SEC2 interrupt not masked</i>	<i>SEC1 interrupt not masked</i>		
<b>Bit No.</b>	<b>Description</b>	<b>Bit Value</b>	<b>Value Description</b>				
7	<i>SEC3 interrupt not masked</i> Mask bit for input SEC3 interrupt.	0 1	Input SEC3 cannot generate interrupts. Input SEC3 can generate interrupts.				
[7:2]	Not used.	-	-				
3	<i>SEC2 interrupt not masked</i> Mask bit for input SEC2 interrupt.	0 1	Input SEC2 cannot generate interrupts. Input SEC2 can generate interrupts.				
2	<i>SEC1 interrupt not masked</i> Mask bit for input SEC1 interrupt.	0 1	Input SEC1 cannot generate interrupts. Input SEC1 can generate interrupts.				
[1:0]	Not used.	-	-				

### Address (hex): 44

<b>Register Name</b>	<i>cnfg_interrupt_mask</i> [15:8]	<b>Description</b>	(R/W) Bits [15:8] of the interrupt mask register.	<b>Default Value</b>	0000 0000		
<b>Bit 7</b>	<b>Bit 6</b>	<b>Bit 5</b>	<b>Bit 4</b>	<b>Bit 3</b>	<b>Bit 2</b>	<b>Bit 1</b>	<b>Bit 0</b>
<i>operating_mode interrupt not masked</i>	<i>main_ref_failed interrupt not masked</i>						<i>SEC4 interrupt not masked</i>
<b>Bit No.</b>	<b>Description</b>	<b>Bit Value</b>	<b>Value Description</b>				
7	<i>operating_mode interrupt not masked</i> Mask bit for <i>operating_mode</i> interrupt.	0 1	Operating mode cannot generate interrupts. Operating mode can generate interrupts.				
6	<i>main_ref_failed interrupt not masked</i> Mask bit for <i>main_ref_failed</i> interrupt.	0 1	Main reference failure cannot generate interrupts. Main reference failure can generate interrupts.				
[5:1]	Not used.	-	-				
0	<i>SEC4 interrupt not masked</i> Mask bit for input SEC4 interrupt.	0 1	Input SEC4 cannot generate interrupts. Input SEC4 can generate interrupts.				

### Address (hex): 45

<b>Register Name</b>	<i>cnfg_interrupt_mask</i> [23:16]	<b>Description</b>	(R/W) Bits [23:16] of the interrupt mask register.	<b>Default Value</b>	0000 0000		
<b>Bit 7</b>	<b>Bit 6</b>	<b>Bit 5</b>	<b>Bit 4</b>	<b>Bit 3</b>	<b>Bit 2</b>	<b>Bit 1</b>	<b>Bit 0</b>
	<i>T4_status</i> <i>interrupt not</i> <i>masked</i>						
<b>Bit No.</b>	<b>Description</b>	<b>Bit Value</b>	<b>Value Description</b>				
7	Not used.	-	-				
6	<i>T4_status</i> Mask bit for <i>T4_status</i> interrupt.	0	Change in <i>T4_status</i> cannot generate interrupts.	1	Change in <i>T4_status</i> can generate interrupts.		
[5:0]	Not used.	-	-				

### Address (hex): 46

<b>Register Name</b>	<i>cnfg_freq_divn</i> [7:0]	<b>Description</b>	(R/W) Bits [7:0] of the division factor for inputs using the DivN feature.	<b>Default Value</b>	1111 1111		
<b>Bit 7</b>	<b>Bit 6</b>	<b>Bit 5</b>	<b>Bit 4</b>	<b>Bit 3</b>	<b>Bit 2</b>	<b>Bit 1</b>	<b>Bit 0</b>
<i>divn_value</i> [7:0]							
<b>Bit No.</b>	<b>Description</b>	<b>Bit Value</b>	<b>Value Description</b>				
[7:0]	<i>divn_value</i> [7:0]	-	See Reg. 47 ( <i>cnfg_freq_divn</i> ) for details.				

### Address (hex): 47

<b>Register Name</b>	<i>cnfg_freq_divn</i> [13:8]	<b>Description</b>	(R/W) Bits [13:8] of the division factor for inputs using the DivN feature.	<b>Default Value</b>	0011 1111		
<b>Bit 7</b>	<b>Bit 6</b>	<b>Bit 5</b>	<b>Bit 4</b>	<b>Bit 3</b>	<b>Bit 2</b>	<b>Bit 1</b>	<b>Bit 0</b>
<i>divn_value</i> [13:8]							
<b>Bit No.</b>	<b>Description</b>	<b>Bit Value</b>	<b>Value Description</b>				
[7:6]	Not used.	-	-				

### Address (hex): 47 (cont...)

<b>Register Name</b>	<i>cnfg_freq_divn</i> [13:8]	<b>Description</b>	(R/W) Bits [13:8] of the division factor for inputs using the DivN feature.	<b>Default Value</b>	0011 1111		
<b>Bit 7</b>	<b>Bit 6</b>	<b>Bit 5</b>	<b>Bit 4</b>	<b>Bit 3</b>	<b>Bit 2</b>	<b>Bit 1</b>	<b>Bit 0</b>
<i>divn_value</i> [13:8]							
<b>Bit No.</b>	<b>Description</b>	<b>Bit Value</b>	<b>Value Description</b>				
[5:0]	<i>divn_value</i> [13:8] This register, in conjunction with Reg. 46 ( <i>cnfg_freq_divn</i> ) represents the integer value by which to divide inputs that use the DivN pre-divider. The divn feature supports input frequencies up to a maximum of 100 MHz; therefore, the maximum value that should be written to this register is 30D3 hex (12499 dec.). Use of higher DivN values may result in unreliable behavior.	-	The input frequency will be divided by the value in this register plus 1. i.e. to divide by 8, program a value of 7.				

### Address (hex): 48

<b>Register Name</b>	<i>cnfg_monitors</i>	<b>Description</b>	(R/W) Configuration register controlling several input monitoring and switching options.	<b>Default Value</b>	0000 0101*		
<b>Bit 7</b>	<b>Bit 6</b>	<b>Bit 5</b>	<b>Bit 4</b>	<b>Bit 3</b>	<b>Bit 2</b>	<b>Bit 1</b>	<b>Bit 0</b>
<i>freq_mon_clk</i>	<i>los_flag_on_TDO</i>	<i>ultra_fast_switch</i>	<i>ext_switch</i>	<i>PBO_freeze</i>	<i>PBO_en</i>	<i>freq_monitor_soft_enable</i>	<i>freq_monitor_hard_enable</i>
<b>Bit No.</b>	<b>Description</b>	<b>Bit Value</b>	<b>Value Description</b>				
7	<i>freq_mon_clk</i> Bit to select the source of the clock to the frequency monitors to be either from the output clock or directly from the crystal oscillator.	0 1	Frequency monitors clocked by output of TO DPLL. Frequency monitors clocked by crystal oscillator frequency.				
6	<i>los_flag_on_TDO</i> Bit to select whether the <i>main_ref_fail</i> interrupt from the TO DPLL is flagged on the TDO pin. If enabled this will not strictly conform to the IEEE 1149.1 JTAG standard for the function of the TDO pin. When enabled the TDO pin will simply mimic the state of the <i>main_ref_fail</i> interrupt status bit.	0 1	Normal mode, TDO complies with IEEE 1149.1. TDO pin used to indicate the state of the <i>main_ref_fail</i> interrupt status. This allows a system to have a hardware indication of a source failure very rapidly.				
5	<i>ultra_fast_switch</i> Bit to enable ultra-fast switching mode. When in this mode, the device will disqualify a locked-to source as soon as it detects a few missing input cycles.	0 1	Currently selected source only disqualified by Leaky Bucket or frequency monitors. Currently selected source disqualified after less than 3 missing input cycles.				

Address (hex): **48** (cont...)

<b>Register Name</b>	<i>cnfg_monitors</i>		<b>Description</b>	(R/W) Configuration register controlling several input monitoring and switching options.		<b>Default Value</b>	0000 0101*
<b>Bit 7</b>	<b>Bit 6</b>	<b>Bit 5</b>	<b>Bit 4</b>	<b>Bit 3</b>	<b>Bit 2</b>	<b>Bit 1</b>	<b>Bit 0</b>
<i>freq_mon_clk</i>	<i>los_flag_on_TDO</i>	<i>ultra_fast_switch</i>	<i>ext_switch</i>	<i>PBO_freeze</i>	<i>PBO_en</i>	<i>freq_monitor_soft_enable</i>	<i>freq_monitor_hard_enable</i>
<b>Bit No.</b>	<b>Description</b>	<b>Bit Value</b>	<b>Value Description</b>				
4	<i>ext_switch</i> Bit to enable external switching mode. When in external switching mode, the device is only allowed to lock to a pair of sources. If the SRC5W pin is <i>High</i> , the device will be forced to lock to input SEC1 regardless of the signal present on that input. If the SRC5W pin is <i>Low</i> , the device will be forced to lock to input SEC2 regardless of the signal present on that input. * The default value of this bit is dependent on the value of the SRC5W pin at power-up.	0 1	Normal operation mode. External source switching mode enabled. Operating mode of the device is always forced to be "locked" when in this mode.				
3	<i>PBO_freeze</i> Bit to control the freezing of Phase Build-out operation. If Phase Build-out has been enabled and there have been some source switches, then the input-output phase relationship of the TO DPLL is unknown. If Phase Build-out is no longer required, then it can be frozen. This will maintain the current input-output phase relationship, but not allow further Phase Build-out events to take place. Simply disabling Phase Build-out could cause a phase shift in the output, as the TO DPLL re-locks the phase to zero degrees.	0 1	Phase Build-out not frozen. Phase Build-out frozen, no further Phase Build-out events will occur.				
2	<i>PBO_en</i> Bit to enable Phase Build-out events on source switching. When enabled a Phase Build-out event is triggered every time the TO DPLL selects a new source- this includes exiting the Holdover or Free-run states.	0 1	Phase Build-out not enabled. TO DPLL locks to zero degrees phase. Phase Build-out enabled on source switching.				
1	<i>freq_monitor_soft_enable</i> Control to enable frequency monitoring of input reference sources using soft frequency alarms.	0 1	Soft frequency monitor alarms disabled. Soft frequency monitor alarms enabled.				
0	<i>freq_monitor_hard_enable</i> Control to enable frequency monitoring of input reference sources using hard frequency alarms.	0 1	Hard frequency monitor alarms disabled. Hard frequency monitor alarms enabled.				



Address (hex): **49**

<b>Register Name</b>	<i>cnfg_freq_mon_threshold</i>	<b>Description</b>	(R/W) Register to set both the hard and soft frequency alarm limits for the monitors on the input reference sources.	<b>Default Value</b>	0010 0011		
<b>Bit 7</b>	<b>Bit 6</b>	<b>Bit 5</b>	<b>Bit 4</b>	<b>Bit 3</b>	<b>Bit 2</b>	<b>Bit 1</b>	<b>Bit 0</b>
<i>soft_frequency_alarm_threshold</i>				<i>hard_frequency_alarm_threshold</i>			
<b>Bit No.</b>	<b>Description</b>	<b>Bit Value</b>	<b>Value Description</b>				
[7:4]	<i>soft_frequency_alarm_threshold</i> Threshold to trigger the soft frequency alarms in the <i>sts_reference_sources</i> registers. This is only used for monitoring.	-	To calculate the limit in ppm, add one to the 4-bit value in the register, and multiply by 3.81 ppm. The limit is symmetrical about zero. A value of 0010 bin corresponds to an alarm limit of $\pm 11.43$ ppm.				
[3:0]	<i>hard_frequency_alarm_threshold</i> Threshold to trigger the hard frequency alarms in the <i>sts_reference_sources</i> registers, which can cause a reference source rejection.		To calculate the limit in ppm, add one to the 4-bit value in the register, and multiply by 3.81 ppm. The limit is symmetrical about zero. A value of 0011 bin corresponds to an alarm limit of $\pm 15.24$ ppm.				

Address (hex): **4A**

<b>Register Name</b>	<i>cnfg_current_freq_mon_threshold</i>	<b>Description</b>	(R/W) Register to set both the hard and soft frequency alarm limits for the monitors on the currently selected reference source.	<b>Default Value</b>	0010 0011		
<b>Bit 7</b>	<b>Bit 6</b>	<b>Bit 5</b>	<b>Bit 4</b>	<b>Bit 3</b>	<b>Bit 2</b>	<b>Bit 1</b>	<b>Bit 0</b>
<i>current_soft_frequency_alarm_threshold</i>				<i>current_hard_frequency_alarm_threshold</i>			
<b>Bit No.</b>	<b>Description</b>	<b>Bit Value</b>	<b>Value Description</b>				
[7:4]	<i>current_soft_frequency_alarm_threshold</i> Threshold to trigger the soft frequency alarm in the <i>sts_reference_sources</i> register applying to the currently selected source. The currently selected source can be monitored for frequency using different limits to all other sources.	-	To calculate the limit in ppm, add one to the 4-bit value in the register, and multiply by 3.81 ppm. The limit is symmetrical about zero. A value of 0010 bin corresponds to an alarm limit of $\pm 11.43$ ppm.				
[3:0]	<i>current_hard_frequency_alarm_threshold</i> Threshold to trigger the hard frequency alarm in the <i>sts_reference_sources</i> register applying to the currently selected source.		To calculate the limit in ppm, add one to the 4-bit value in the register, and multiply by 3.81 ppm. The limit is symmetrical about zero. A value of 0011 bin corresponds to an alarm limit of $\pm 15.24$ ppm.				

### Address (hex): 4B

<b>Register Name</b>	<i>cnfg_registers_source_select</i>	<b>Description</b>	(R/W) Register to select the source of many of the registers.	<b>Default Value</b>	0000 0000		
<b>Bit 7</b>	<b>Bit 6</b>	<b>Bit 5</b>	<b>Bit 4</b>	<b>Bit 3</b>	<b>Bit 2</b>	<b>Bit 1</b>	<b>Bit 0</b>
			<i>T4_TO_select</i>	<i>frequency_measurement_channel_select</i>			
<b>Bit No.</b>	<b>Description</b>	<b>Bit Value</b>	<b>Value Description</b>				
[7:5]	Not used.	-	-				
4	<i>T4_TO_select</i> Bit to select between the T0 and T4 path for: Reg. 0A, 0B ( <i>sts_priority_table</i> ) Reg. 0C, 0D and 07 ( <i>sts_current_DPLL_frequency</i> ) Reg. 77, 78 ( <i>sts_current_phase</i> )	0 1	T0 path registers selected. T4 path registers selected.				
[3:0]	<i>frequency_measurement_channel_select</i> Register to select which input channel the frequency measurement result in Reg. 4C ( <i>sts_freq_measurement</i> ) is taken from.	0011 0111 1000 1001 All other values	Frequency measurement taken from input SEC1. Frequency measurement taken from input SEC2. Frequency measurement taken from input SEC3. Frequency measurement taken from input SEC4. Not used- refers to no input channel.				

### Address (hex): 4C

<b>Register Name</b>	<i>sts_freq_measurement</i>	<b>Description</b>	(RO) Register from which the frequency measurement result can be read.	<b>Default Value</b>	0000 0000		
<b>Bit 7</b>	<b>Bit 6</b>	<b>Bit 5</b>	<b>Bit 4</b>	<b>Bit 3</b>	<b>Bit 2</b>	<b>Bit 1</b>	<b>Bit 0</b>
<i>freq_measurement_value</i>							
<b>Bit No.</b>	<b>Description</b>	<b>Bit Value</b>	<b>Value Description</b>				
[7:0]	<i>freq_measurement_value</i> This represents the value of the frequency measurement on the channel number selected in Reg. 4B ( <i>cnfg_registers_source_select</i> ). This value will represent the offset in frequency from the clock to the frequency monitors. This can be either the crystal oscillator to the device, or the output of the T0 DPLL as selected in Reg. 48 Bit 7 <i>cnfg_monitors</i> .	-	This is an 8-bit 2's complement signed integer. To calculate the offset in ppm of the selected input channel, this value should be multiplied by 3.81 ppm.				

### Address (hex): 4D

<b>Register Name</b>	<i>cnfg_DPLL_soft_limit</i>	<b>Description</b>	(R/W) Register to program the soft frequency limit of the two DPLLs. Exceeding this limit will have no effect beyond triggering a flag.	<b>Default Value</b>	1000 1110		
<b>Bit 7</b>	<b>Bit 6</b>	<b>Bit 5</b>	<b>Bit 4</b>	<b>Bit 3</b>	<b>Bit 2</b>	<b>Bit 1</b>	<b>Bit 0</b>
<i>freq_lim_ph_loss</i>	<i>DPLL_soft_limit_value</i>						
<b>Bit No.</b>	<b>Description</b>	<b>Bit Value</b>	<b>Value Description</b>				
7	<i>freq_lim_ph_loss</i> Bit to enable the phase lost indication when the DPLL hits its <i>hard</i> frequency limit as programmed in Reg. 41 and Reg. 42 ( <i>cnfg_DPLL_freq_limit</i> ). This results in the DPLL entering the phase lost state any time the DPLL tracks to the extent of its hard limit.	0 1	Phase lost/locked determined normally. Phase lost forced when DPLL tracks to hard limit.				
[6:0]	<i>DPLL_soft_limit_value</i> Register to program to what extent either of the DPLLs tracks a source before raising its soft frequency alarm flag (Bits 5 and 4 of Reg. 09, <i>sts_operating</i> ). This offset is compared to the crystal oscillator frequency taking into account any programmed calibration.	-	To calculate the ppm offset multiply this 7-bit value by 0.628 ppm. The limit is symmetrical about zero. A value of 0001110 bin is equivalent to ±8.79 ppm.				

### Address (hex): 50

<b>Register Name</b>	<i>cnfg_upper_threshold_0</i>	<b>Description</b>	(R/W) Register to program the activity alarm setting limit for Leaky Bucket Configuration 0.	<b>Default Value</b>	0000 0110		
<b>Bit 7</b>	<b>Bit 6</b>	<b>Bit 5</b>	<b>Bit 4</b>	<b>Bit 3</b>	<b>Bit 2</b>	<b>Bit 1</b>	<b>Bit 0</b>
Leaky Bucket Configuration <i>upper_threshold_0_value</i>							
<b>Bit No.</b>	<b>Description</b>	<b>Bit Value</b>	<b>Value Description</b>				
[7:0]	<i>upper_threshold_0_value</i> The Leaky Bucket operates on a 128 ms cycle. If, during a cycle, it detects that an input has either failed or has been erratic, then for each cycle in which this occurs, the accumulator is incremented by 1, and for each period of 1, 2, 4, or 8 cycles, as programmed in Reg. 53 ( <i>cnfg_decay_rate_0</i> ), in which this does not occur, the accumulator is decremented by 1.  When the accumulator count reaches the value programmed as the <i>upper_threshold_0_value</i> , the Leaky Bucket raises an input inactivity alarm.	-	Value at which the Leaky Bucket will raise an inactivity alarm.				

### Address (hex): 51

<b>Register Name</b>	<i>cnfg_lower_threshold_0</i>	<b>Description</b>	(R/W) Register to program the activity alarm resetting limit for Leaky Bucket Configuration 0.	<b>Default Value</b>	0000 0100		
<b>Bit 7</b>	<b>Bit 6</b>	<b>Bit 5</b>	<b>Bit 4</b>	<b>Bit 3</b>	<b>Bit 2</b>	<b>Bit 1</b>	<b>Bit 0</b>
Leaky Bucket Configuration <i>lower_threshold_0_value</i>							
<b>Bit No.</b>	<b>Description</b>	<b>Bit Value</b>	<b>Value Description</b>				
[7:0]	<p><i>lower_threshold_0_value</i> The Leaky Bucket operates on a 128 ms cycle. If, during a cycle, it detects that an input has either failed or has been erratic, then for each cycle in which this occurs, the accumulator is incremented by 1, and for each period of 1, 2, 4, or 8 cycles, as programmed in Reg. 53 (<i>cnfg_decay_rate_0</i>), in which this does not occur, the accumulator is decremented by 1.</p> <p>The <i>lower_threshold_0_value</i> is the value at which the Leaky Bucket will reset an inactivity alarm.</p>	-	Value at which the Leaky Bucket will reset an inactivity alarm.				

### Address (hex): 52

<b>Register Name</b>	<i>cnfg_bucket_size_0</i>	<b>Description</b>	(R/W) Register to program the maximum size limit for Leaky Bucket Configuration 0.	<b>Default Value</b>	0000 1000		
<b>Bit 7</b>	<b>Bit 6</b>	<b>Bit 5</b>	<b>Bit 4</b>	<b>Bit 3</b>	<b>Bit 2</b>	<b>Bit 1</b>	<b>Bit 0</b>
Leaky Bucket Configuration <i>bucket_size_0_value</i>							
<b>Bit No.</b>	<b>Description</b>	<b>Bit Value</b>	<b>Value Description</b>				
[7:0]	<p><i>bucket_size_0_value</i> The Leaky Bucket operates on a 128 ms cycle. If, during a cycle, it detects that an input has either failed or has been erratic, then for each cycle in which this occurs, the accumulator is incremented by 1, and for each period of 1, 2, 4, or 8 cycles, as programmed in Reg. 53 (<i>cnfg_decay_rate_0</i>), in which this does not occur, the accumulator is decremented by 1.</p> <p>The number in the Bucket cannot exceed the value programmed into this register.</p>	-	Value at which the Leaky Bucket will stop incrementing, even with further inactive periods.				

Address (hex): **53**

<b>Register Name</b>	<i>cnfg_decay_rate_0</i>	<b>Description</b>	(R/W) Register to program the “decay” or “leak” rate for Leaky Bucket Configuration 0.				<b>Default Value</b>	0000 0001
<b>Bit 7</b>	<b>Bit 6</b>	<b>Bit 5</b>	<b>Bit 4</b>	<b>Bit 3</b>	<b>Bit 2</b>	<b>Bit 1</b>	<b>Bit 0</b>	
						Leaky Bucket Configuration <i>decay_rate_0_value</i>		
<b>Bit No.</b>	<b>Description</b>	<b>Bit Value</b>	<b>Value Description</b>					
[7:2]	Not used.	-	-					
[1:0]	<i>decay_rate_0_value</i> The Leaky Bucket operates on a 128 ms cycle. If, during a cycle, it detects that an input has either failed or has been erratic, then for each cycle in which this occurs, the accumulator is incremented by 1, and for each period of 1, 2, 4, or 8 cycles, as programmed in this register, in which this does not occur, the accumulator is decremented by 1.  The Leaky Bucket can be programmed to “leak” or “decay” at the same rate as the “fill” cycle, or effectively at one half, one quarter, or one eighth of the fill rate.	00 01 10 11	Bucket decay rate of 1 every 128 ms. Bucket decay rate of 1 every 256 ms. Bucket decay rate of 1 every 512 ms. Bucket decay rate of 1 every 1024 ms.					

Address (hex): **54**

<b>Register Name</b>	<i>cnfg_upper_threshold_1</i>	<b>Description</b>	(R/W) Register to program the activity alarm setting limit for Leaky Bucket Configuration 1.				<b>Default Value</b>	0000 0110
<b>Bit 7</b>	<b>Bit 6</b>	<b>Bit 5</b>	<b>Bit 4</b>	<b>Bit 3</b>	<b>Bit 2</b>	<b>Bit 1</b>	<b>Bit 0</b>	
Leaky Bucket Configuration <i>upper_threshold_1_value</i>								
<b>Bit No.</b>	<b>Description</b>	<b>Bit Value</b>	<b>Value Description</b>					
[7:0]	<i>upper_threshold_1_value</i> The Leaky Bucket operates on a 128 ms cycle. If, during a cycle, it detects that an input has either failed or has been erratic, then for each cycle in which this occurs, the accumulator is incremented by 1, and for each period of 1, 2, 4, or 8 cycles, as programmed in Reg. 57 ( <i>cnfg_decay_rate_1</i> ), in which this does not occur, the accumulator is decremented by 1.  When the accumulator count reaches the value programmed as the <i>upper_threshold_1_value</i> , the Leaky Bucket raises an input inactivity alarm.	-	Value at which the Leaky Bucket will raise an inactivity alarm.					

Address (hex): **55**

<b>Register Name</b>	<i>cnfg_lower_threshold_1</i>	<b>Description</b>	(R/W) Register to program the activity alarm resetting limit for Leaky Bucket Configuration 1.	<b>Default Value</b>	0000 0100		
<b>Bit 7</b>	<b>Bit 6</b>	<b>Bit 5</b>	<b>Bit 4</b>	<b>Bit 3</b>	<b>Bit 2</b>	<b>Bit 1</b>	<b>Bit 0</b>
Leaky Bucket Configuration <i>lower_threshold_1_value</i>							
<b>Bit No.</b>	<b>Description</b>	<b>Bit Value</b>	<b>Value Description</b>				
[7:0]	<p><i>lower_threshold_1_value</i></p> <p>The Leaky Bucket operates on a 128 ms cycle. If, during a cycle, it detects that an input has either failed or has been erratic, then for each cycle in which this occurs, the accumulator is incremented by 1, and for each period of 1, 2, 4, or 8 cycles, as programmed in Reg. 57 (<i>cnfg_decay_rate_1</i>), in which this does not occur, the accumulator is decremented by 1.</p> <p>The <i>lower_threshold_1_value</i> is the value at which the Leaky Bucket will reset an inactivity alarm.</p>	-	Value at which the Leaky Bucket will reset an inactivity alarm.				

Address (hex): **56**

<b>Register Name</b>	<i>cnfg_bucket_size_1</i>	<b>Description</b>	(R/W) Register to program the maximum size limit for Leaky Bucket Configuration 1.	<b>Default Value</b>	0000 1000		
<b>Bit 7</b>	<b>Bit 6</b>	<b>Bit 5</b>	<b>Bit 4</b>	<b>Bit 3</b>	<b>Bit 2</b>	<b>Bit 1</b>	<b>Bit 0</b>
Leaky Bucket Configuration <i>bucket_size_1_value</i>							
<b>Bit No.</b>	<b>Description</b>	<b>Bit Value</b>	<b>Value Description</b>				
[7:0]	<p><i>bucket_size_1_value</i></p> <p>The Leaky Bucket operates on a 128 ms cycle. If, during a cycle, it detects that an input has either failed or has been erratic, then for each cycle in which this occurs, the accumulator is incremented by 1, and for each period of 1, 2, 4, or 8 cycles, as programmed in Reg. 57 (<i>cnfg_decay_rate_1</i>), in which this does not occur, the accumulator is decremented by 1.</p> <p>The number in the Bucket cannot exceed the value programmed into this register.</p>	-	Value at which the Leaky Bucket will stop incrementing, even with further inactive periods.				

Address (hex): **57**

<b>Register Name</b>	<i>cnfg_decay_rate_1</i>	<b>Description</b>	(R/W) Register to program the “decay” or “leak” rate for Leaky Bucket Configuration 1.				<b>Default Value</b>	0000 0001
<b>Bit 7</b>	<b>Bit 6</b>	<b>Bit 5</b>	<b>Bit 4</b>	<b>Bit 3</b>	<b>Bit 2</b>	<b>Bit 1</b>	<b>Bit 0</b>	
						Leaky Bucket Configuration <i>decay_rate_1_value</i>		
<b>Bit No.</b>	<b>Description</b>	<b>Bit Value</b>	<b>Value Description</b>					
[7:2]	Not used.	-	-					
[1:0]	<i>decay_rate_1_value</i> The Leaky Bucket operates on a 128 ms cycle. If, during a cycle, it detects that an input has either failed or has been erratic, then for each cycle in which this occurs, the accumulator is incremented by 1, and for each period of 1, 2, 4, or 8 cycles, as programmed in this register, in which this does not occur, the accumulator is decremented by 1.  The Leaky Bucket can be programmed to “leak” or “decay” at the same rate as the “fill” cycle, or effectively at one half, one quarter, or one eighth of the fill rate.	00 01 10 11	Bucket decay rate of 1 every 128 ms. Bucket decay rate of 1 every 256 ms. Bucket decay rate of 1 every 512 ms. Bucket decay rate of 1 every 1024 ms.					

Address (hex): **58**

<b>Register Name</b>	<i>cnfg_upper_threshold_2</i>	<b>Description</b>	(R/W) Register to program the activity alarm setting limit for Leaky Bucket Configuration 2.				<b>Default Value</b>	0000 0110
<b>Bit 7</b>	<b>Bit 6</b>	<b>Bit 5</b>	<b>Bit 4</b>	<b>Bit 3</b>	<b>Bit 2</b>	<b>Bit 1</b>	<b>Bit 0</b>	
Leaky Bucket Configuration <i>upper_threshold_2_value</i>								
<b>Bit No.</b>	<b>Description</b>	<b>Bit Value</b>	<b>Value Description</b>					
[7:0]	<i>upper_threshold_2_value</i> The Leaky Bucket operates on a 128 ms cycle. If, during a cycle, it detects that an input has either failed or has been erratic, then for each cycle in which this occurs, the accumulator is incremented by 1, and for each period of 1, 2, 4, or 8 cycles, as programmed in Reg. 5B ( <i>cnfg_decay_rate_2</i> ), in which this does not occur, the accumulator is decremented by 1.  When the accumulator count reaches the value programmed as the <i>upper_threshold_2_value</i> , the Leaky Bucket raises an input inactivity alarm.	-	Value at which the Leaky Bucket will raise an inactivity alarm.					

Address (hex): **59**

<b>Register Name</b>	<i>cnfg_lower_threshold_2</i>	<b>Description</b>	(R/W) Register to program the activity alarm resetting limit for Leaky Bucket Configuration 2.	<b>Default Value</b>	0000 0100		
<b>Bit 7</b>	<b>Bit 6</b>	<b>Bit 5</b>	<b>Bit 4</b>	<b>Bit 3</b>	<b>Bit 2</b>	<b>Bit 1</b>	<b>Bit 0</b>
Leaky Bucket Configuration <i>lower_threshold_2_value</i>							
<b>Bit No.</b>	<b>Description</b>	<b>Bit Value</b>	<b>Value Description</b>				
[7:0]	<p><i>lower_threshold_2_value</i></p> <p>The Leaky Bucket operates on a 128 ms cycle. If, during a cycle, it detects that an input has either failed or has been erratic, then for each cycle in which this occurs, the accumulator is incremented by 1, and for each period of 1, 2, 4, or 8 cycles, as programmed in Reg. 5B (<i>cnfg_decay_rate_2</i>), in which this does not occur, the accumulator is decremented by 1.</p> <p>The <i>lower_threshold_2_value</i> is the value at which the Leaky Bucket will reset an inactivity alarm.</p>	-	Value at which the Leaky Bucket will reset an inactivity alarm.				

Address (hex): **5A**

<b>Register Name</b>	<i>cnfg_bucket_size_2</i>	<b>Description</b>	(R/W) Register to program the maximum size limit for Leaky Bucket Configuration 2.	<b>Default Value</b>	0000 1000		
<b>Bit 7</b>	<b>Bit 6</b>	<b>Bit 5</b>	<b>Bit 4</b>	<b>Bit 3</b>	<b>Bit 2</b>	<b>Bit 1</b>	<b>Bit 0</b>
Leaky Bucket Configuration <i>bucket_size_2_value</i>							
<b>Bit No.</b>	<b>Description</b>	<b>Bit Value</b>	<b>Value Description</b>				
[7:0]	<p><i>bucket_size_2_value</i></p> <p>The Leaky Bucket operates on a 128 ms cycle. If, during a cycle, it detects that an input has either failed or has been erratic, then for each cycle in which this occurs, the accumulator is incremented by 1, and for each period of 1, 2, 4, or 8 cycles, as programmed in Reg. 5B (<i>cnfg_decay_rate_2</i>), in which this does not occur, the accumulator is decremented by 1.</p> <p>The number in the Bucket cannot exceed the value programmed into this register.</p>	-	Value at which the Leaky Bucket will stop incrementing, even with further inactive periods.				



### Address (hex): 5B

<b>Register Name</b>	<i>cnfg_decay_rate_2</i>	<b>Description</b>	(R/W) Register to program the “decay” or “leak” rate for Leaky Bucket Configuration 2.				<b>Default Value</b>	0000 0001
<b>Bit 7</b>	<b>Bit 6</b>	<b>Bit 5</b>	<b>Bit 4</b>	<b>Bit 3</b>	<b>Bit 2</b>	<b>Bit 1</b>	<b>Bit 0</b>	
						Leaky Bucket Configuration <i>decay_rate_2_value</i>		
<b>Bit No.</b>	<b>Description</b>	<b>Bit Value</b>	<b>Value Description</b>					
[7:2]	Not used.	-	-					
[1:0]	<i>decay_rate_2_value</i> The Leaky Bucket operates on a 128 ms cycle. If, during a cycle, it detects that an input has either failed or has been erratic, then for each cycle in which this occurs, the accumulator is incremented by 1, and for each period of 1, 2, 4, or 8 cycles, as programmed in this register, in which this does not occur, the accumulator is decremented by 1.  The Leaky Bucket can be programmed to “leak” or “decay” at the same rate as the “fill” cycle, or effectively at one half, one quarter, or one eighth of the fill rate.	00 01 10 11	Bucket decay rate of 1 every 128 ms. Bucket decay rate of 1 every 256 ms. Bucket decay rate of 1 every 512 ms. Bucket decay rate of 1 every 1024 ms.					

### Address (hex): 5C

<b>Register Name</b>	<i>cnfg_upper_threshold_3</i>	<b>Description</b>	(R/W) Register to program the activity alarm setting limit for Leaky Bucket Configuration 3.				<b>Default Value</b>	0000 0110
<b>Bit 7</b>	<b>Bit 6</b>	<b>Bit 5</b>	<b>Bit 4</b>	<b>Bit 3</b>	<b>Bit 2</b>	<b>Bit 1</b>	<b>Bit 0</b>	
Leaky Bucket Configuration <i>upper_threshold_3_value</i>								
<b>Bit No.</b>	<b>Description</b>	<b>Bit Value</b>	<b>Value Description</b>					
[7:0]	<i>upper_threshold_3_value</i> The Leaky Bucket operates on a 128 ms cycle. If, during a cycle, it detects that an input has either failed or has been erratic, then for each cycle in which this occurs, the accumulator is incremented by 1, and for each period of 1, 2, 4, or 8 cycles, as programmed in Reg. 5F ( <i>cnfg_decay_rate_3</i> ), in which this does not occur, the accumulator is decremented by 1.  When the accumulator count reaches the value programmed as the <i>upper_threshold_3_value</i> , the Leaky Bucket raises an input inactivity alarm.	-	Value at which the Leaky Bucket will raise an inactivity alarm.					

Address (hex): **5D**

<b>Register Name</b>	<i>cnfg_lower_threshold_3</i>	<b>Description</b>	(R/W) Register to program the activity alarm resetting limit for Leaky Bucket Configuration 3.	<b>Default Value</b>	0000 0100		
<b>Bit 7</b>	<b>Bit 6</b>	<b>Bit 5</b>	<b>Bit 4</b>	<b>Bit 3</b>	<b>Bit 2</b>	<b>Bit 1</b>	<b>Bit 0</b>
Leaky Bucket Configuration <i>lower_threshold_3_value</i>							
<b>Bit No.</b>	<b>Description</b>	<b>Bit Value</b>	<b>Value Description</b>				
[7:0]	<p><i>lower_threshold_3_value</i></p> <p>The Leaky Bucket operates on a 128 ms cycle. If, during a cycle, it detects that an input has either failed or has been erratic, then for each cycle in which this occurs, the accumulator is incremented by 1, and for each period of 1, 2, 4, or 8 cycles, as programmed in Reg. 5F (<i>cnfg_decay_rate_3</i>), in which this does not occur, the accumulator is decremented by 1.</p> <p>The <i>lower_threshold_3_value</i> is the value at which the Leaky Bucket will reset an inactivity alarm.</p>	-	Value at which the Leaky Bucket will reset an inactivity alarm.				

Address (hex): **5E**

<b>Register Name</b>	<i>cnfg_bucket_size_3</i>	<b>Description</b>	(R/W) Register to program the maximum size limit for Leaky Bucket Configuration 3.	<b>Default Value</b>	0000 1000		
<b>Bit 7</b>	<b>Bit 6</b>	<b>Bit 5</b>	<b>Bit 4</b>	<b>Bit 3</b>	<b>Bit 2</b>	<b>Bit 1</b>	<b>Bit 0</b>
Leaky Bucket Configuration <i>bucket_size_3_value</i>							
<b>Bit No.</b>	<b>Description</b>	<b>Bit Value</b>	<b>Value Description</b>				
[7:0]	<p><i>bucket_size_3_value</i></p> <p>The Leaky Bucket operates on a 128 ms cycle. If, during a cycle, it detects that an input has either failed or has been erratic, then for each cycle in which this occurs, the accumulator is incremented by 1, and for each period of 1, 2, 4, or 8 cycles, as programmed in Reg. 5F (<i>cnfg_decay_rate_3</i>), in which this does not occur, the accumulator is decremented by 1.</p> <p>The number in the Bucket cannot exceed the value programmed into this register.</p>	-	Value at which the Leaky Bucket will stop incrementing, even with further inactive periods.				

Address (hex): **5F**

<b>Register Name</b>	<i>cnfg_decay_rate_3</i>	<b>Description</b>	(R/W) Register to program the “decay” or “leak” rate for Leaky Bucket Configuration 3.				<b>Default Value</b>	0000 0001
<b>Bit 7</b>	<b>Bit 6</b>	<b>Bit 5</b>	<b>Bit 4</b>	<b>Bit 3</b>	<b>Bit 2</b>	<b>Bit 1</b>	<b>Bit 0</b>	
						Leaky Bucket Configuration <i>decay_rate_3_value</i>		
<b>Bit No.</b>	<b>Description</b>	<b>Bit Value</b>	<b>Value Description</b>					
[7:2]	Not used.	-	-					
[1:0]	<i>decay_rate_3_value</i> The Leaky Bucket operates on a 128 ms cycle. If, during a cycle, it detects that an input has either failed or has been erratic, then for each cycle in which this occurs, the accumulator is incremented by 1, and for each period of 1, 2, 4, or 8 cycles, as programmed in this register, in which this does not occur, the accumulator is decremented by 1.  The Leaky Bucket can be programmed to “leak” or “decay” at the same rate as the “fill” cycle, or effectively at one half, one quarter, or one eighth of the fill rate.	00 01 10 11	Bucket decay rate of 1 every 128 ms. Bucket decay rate of 1 every 256 ms. Bucket decay rate of 1 every 512 ms. Bucket decay rate of 1 every 1024 ms.					

### Address (hex): 60

<b>Register Name</b>	<i>cnfg_output_frequency</i> (02)	<b>Description</b>	(R/W) Register to configure and enable the frequencies available on output O2.	<b>Default Value</b>	1000 0000		
<b>Bit 7</b>	<b>Bit 6</b>	<b>Bit 5</b>	<b>Bit 4</b>	<b>Bit 3</b>	<b>Bit 2</b>	<b>Bit 1</b>	<b>Bit 0</b>
<i>output_freq_02</i>							
<b>Bit No.</b>	<b>Description</b>	<b>Bit Value</b>	<b>Value Description</b>				
[7:4]	<i>output_freq_02</i> Configuration of the output frequency available at output O2. Many of the frequencies available are dependent on the frequencies of the T0 APLL and the T4 APLL. These are configured in Reg. 64 and Reg. 65. For more detail see the detailed section on configuring the output frequencies.	0000 0001 0010 0011 0100 0101 0110 0111 1000 1001 1010 1011 1100 1101 1110 1111	Output disabled. 2 kHz. 8 kHz. Digital2 (Reg. 39 <i>cnfg_digital_frequencies</i> ). Digital1 (Reg. 39 <i>cnfg_digital_frequencies</i> ). T0 APLL frequency/48. T0 APLL frequency/16. T0 APLL frequency/12. T0 APLL frequency/8. T0 APLL frequency/6. T0 APLL frequency/4. T4 APLL frequency/64. T4 APLL frequency/48. T4 APLL frequency/16. T4 APLL frequency/8. T4 APLL frequency/4.				
[3:0]	Not used.	-	-				

### Address (hex): 61

<b>Register Name</b>	<i>cnfg_output_frequency</i> (03)	<b>Description</b>	(R/W) Register to configure and enable the frequencies available on outputs O3.	<b>Default Value</b>	0000 0110		
<b>Bit 7</b>	<b>Bit 6</b>	<b>Bit 5</b>	<b>Bit 4</b>	<b>Bit 3</b>	<b>Bit 2</b>	<b>Bit 1</b>	<b>Bit 0</b>
				<i>output_freq_03</i>			
<b>Bit No.</b>	<b>Description</b>	<b>Bit Value</b>	<b>Value Description</b>				
[7:4]	Not used.	-	-				

**Address (hex): 61 (cont...)**

<b>Register Name</b>	<i>cnfg_output_frequency</i> (03)	<b>Description</b>	(R/W) Register to configure and enable the frequencies available on outputs O3.	<b>Default Value</b>	0000 0110		
<b>Bit 7</b>	<b>Bit 6</b>	<b>Bit 5</b>	<b>Bit 4</b>	<b>Bit 3</b>	<b>Bit 2</b>	<b>Bit 1</b>	<b>Bit 0</b>
				<i>output_freq_O3</i>			
<b>Bit No.</b>	<b>Description</b>	<b>Bit Value</b>	<b>Value Description</b>				
[3:0]	<i>output_freq_O3</i> Configuration of the output frequency available at output O3. Many of the frequencies available are dependent on the frequencies of the T0 APLL and the T4 APLL. These are configured in Reg. 64 and Reg. 65. For more detail see the detailed section on configuring the output frequencies.	0000 0001 0010 0011 0100 0101 0110 0111 1000 1001 1010 1011 1100 1101 1110 1111	Output disabled. 2 kHz. 8 kHz. Digital2 (Reg. 39 <i>cnfg_digital_frequencies</i> ). Digital1 (Reg. 39 <i>cnfg_digital_frequencies</i> ). T0 APLL frequency/48. T0 APLL frequency/16. T0 APLL frequency/12. T0 APLL frequency/8. T0 APLL frequency/6. T0 APLL frequency/4. T4 APLL frequency/64. T4 APLL frequency/48. T4 APLL frequency/16. T4 APLL frequency/8. T4 APLL frequency/4.				

Address (hex): **62**

<b>Register Name</b>	<i>cnfg_output_frequency</i> (04 & 01)	<b>Description</b>	(R/W) Register to configure and enable the frequencies available on outputs O4 and O1.	<b>Default Value</b>	1000 0100		
<b>Bit 7</b>	<b>Bit 6</b>	<b>Bit 5</b>	<b>Bit 4</b>	<b>Bit 3</b>	<b>Bit 2</b>	<b>Bit 1</b>	<b>Bit 0</b>
<i>output_freq_01</i>				<i>output_freq_04</i>			
<b>Bit No.</b>	<b>Description</b>	<b>Bit Value</b>	<b>Value Description</b>				
[7:4]	<i>output_freq_01</i> Configuration of the output frequency available at output O1. Many of the frequencies available are dependent on the frequencies of the T0 APLL and the T4 APLL. These are configured in Reg. 64 and Reg. 65. For more detail see the detailed section on configuring the output frequencies.	0000 0001 0010 0011 0100 0101 0110 0111 1000 1001 1010 1011 1100 1101 1110 1111	Output disabled. 2 kHz. 8 kHz. T0 APLL frequency/2. Digital1 (Reg. 39 <i>cnfg_digital_frequencies</i> ). T0 APLL frequency. T0 APLL frequency/16. T0 APLL frequency/12. T0 APLL frequency/8. T0 APLL frequency/6. T0 APLL frequency/4. T4 APLL frequency/64. T4 APLL frequency/48. T4 APLL frequency/16. T4 APLL frequency/8. T4 APLL frequency/4.				
[3:0]	<i>output_freq_04</i> Configuration of the output frequency available at output O4. Many of the frequencies available are dependent on the frequencies of the T0 APLL and the T4 APLL. These are configured in Reg. 64 and Reg. 65. For more detail see the detailed section on configuring the output frequencies.	0000 0001 0010 0011 0100 0101 0110 0111 1000 1001 1010 1011 1100 1101 1110 1111	Output disabled. 2 kHz. 8 kHz. Digital2 (Reg. 39 <i>cnfg_digital_frequencies</i> ). Digital1 (Reg. 39 <i>cnfg_digital_frequencies</i> ). T0 APLL frequency/48. T0 APLL frequency/16. T0 APLL frequency/12. T0 APLL frequency/8. T0 APLL frequency/6. T0 APLL frequency/4. T4 APLL frequency/2. T4 APLL frequency/48. T4 APLL frequency/16. T4 APLL frequency/8. T4 APLL frequency/4.				

### Address (hex): 63

<b>Register Name</b>	<i>cnfg_output_frequency</i> (MFrSync)	<b>Description</b>	(R/W) Register to configure and enable the frequencies available on MFrSync output.	<b>Default Value</b>	1100 0000		
<b>Bit 7</b>	<b>Bit 6</b>	<b>Bit 5</b>	<b>Bit 4</b>	<b>Bit 3</b>	<b>Bit 2</b>	<b>Bit 1</b>	<b>Bit 0</b>
MFrSync_en	FrSync_en						
<b>Bit No.</b>	<b>Description</b>	<b>Bit Value</b>	<b>Value Description</b>				
7	MFrSync_en Register bit to enable the 2 kHz Sync output (MFrSync).	0 1	Output MFrSync disabled. Output MFrSync enabled.				
6	FrSync_en Register bit to enable the 8 kHz Sync output (FrSync).	0 1	Output FrSync disabled. Output FrSync enabled.				
[5:0]	Not used.	-	-				

### Address (hex): 64

<b>Register Name</b>	<i>cnfg_T4_DPLL_frequency</i>	<b>Description</b>	(R/W) Register to configure the T4 DPLL and several other parameters for the T4 path.	<b>Default Value</b>	0000 0101		
<b>Bit 7</b>	<b>Bit 6</b>	<b>Bit 5</b>	<b>Bit 4</b>	<b>Bit 3</b>	<b>Bit 2</b>	<b>Bit 1</b>	<b>Bit 0</b>
					<i>T4_DPLL_frequency</i>		
<b>Bit No.</b>	<b>Description</b>	<b>Bit Value</b>	<b>Value Description</b>				
[7:3]	Not used.	-	-				
[2:0]	T4_DPLL_frequency Register to configure the frequency of operation of the DPLL in the T4 path. The frequency of the DPLL will also affect the frequency of the T4 APLL which, in turn, affects the frequencies available at outputs O1 - O4 see Reg. 60 - Reg. 62. It is also possible to not use the T4 DPLL at all, but use the T4 APLL to run directly from the T0 DPLL output, see Reg. 65 ( <i>cnfg_TO_DPLL_frequency</i> ). If any frequencies are required from the T4 APLL then the T4 DPLL should not be squelched, as the T4 APLL input is squelched and the T4 APLL will free run.	000 001 010 011 100 101 110 111	T4 DPLL squelched (clock off). 77.76 MHz (OC-N rates), T4 APLL frequency = 311.04 MHz. 12E1, T4 APLL frequency = 98.304 MHz. 16E1, T4 APLL frequency = 131.072 MHz. 24DS1, T4 APLL frequency = 148.224 MHz. 16DS1, T4 APLL frequency = 98.816 MHz. E3, T4 APLL frequency = 274.944 MHz. DS3, T4 APLL frequency = 178.944 MHz.				

Address (hex): **65**

<b>Register Name</b>	<i>cnfg_TO_DPLL_frequency</i>	<b>Description</b>	(R/W) Register to configure the TO DPLL and several other parameters for the TO path.	<b>Default Value</b>	0000 0001		
<b>Bit 7</b>	<b>Bit 6</b>	<b>Bit 5</b>	<b>Bit 4</b>	<b>Bit 3</b>	<b>Bit 2</b>	<b>Bit 1</b>	<b>Bit 0</b>
<i>T4_meas_TO_ph</i>	<i>T4_APLL_for_TO</i>	<i>TO_freq_to_T4_APLL</i>			<i>TO_DPLL_frequency</i>		
<b>Bit No.</b>	<b>Description</b>	<b>Bit Value</b>	<b>Value Description</b>				
7	<i>T4_meas_TO_ph</i> Register bit to control the feature to use the T4 path to measure phase offset from the TO path. When enabled the T4 path is disabled and the phase detector is used to measure the phase between the input to the TO DPLL and the selected T4 input.	0 1	Normal- T4 Path normal operation. T4 DPLL disabled, T4 phase detector used to measure phase between selected TO input and selected T4 input.				
6	<i>T4_APLL_for_TO</i> Register bit to select whether the T4 APLL takes its input from the T4 DPLL or the TO DPLL. If the TO DPLL is selected then the frequency is controlled by Bits [5:4], <i>TO_freq_to_T4_APLL</i> .	0 1	T4 APLL takes its input from the T4 DPLL. T4 APLL takes its input from the TO DPLL.				
[5:4]	<i>TO_freq_to_T4_APLL</i> Register to select the TO frequency driven to the T4 APLL when selected by Bit 6, <i>T4_APLL_for_TO</i> .	00 01 10 11	12E1, T4 APLL frequency = 98.304 MHz. 16E1, T4 APLL frequency = 131.072 MHz. 24DS1, T4 APLL frequency = 148.224 MHz. 16DS1, T4 APLL frequency = 98.816 MHz.				
3	Not used.	-	-				
[2:0]	<i>TO_DPLL_frequency</i> Register to configure the frequency of operation of the DPLL/APLL in the TO path. This register affects the frequencies available at outputs O1 to O4, see Reg. 60 - Reg. 63.	000 001 010 011 100 101 110 111	77.76 MHz, digital feedback, TO APLL frequency = 311.04 MHz. 77.76 MHz, analog feedback, TO APLL frequency = 311.04 MHz. 12E1, TO APLL frequency = 98.304 MHz. 16E1, TO APLL frequency = 131.072 MHz. 24DS1, TO APLL frequency = 148.224 MHz. 16DS1, TO APLL frequency = 98.816 MHz. Not used. Not used.				

Address (hex): **66**

<b>Register Name</b>	<i>cnfg_T4_DPLL_bw</i>	<b>Description</b>	(R/W) Register to configure the bandwidth of the T4 DPLL.	<b>Default Value</b>	0000 0000		
<b>Bit 7</b>	<b>Bit 6</b>	<b>Bit 5</b>	<b>Bit 4</b>	<b>Bit 3</b>	<b>Bit 2</b>	<b>Bit 1</b>	<b>Bit 0</b>
						<i>T4_DPLL_bandwidth</i>	
<b>Bit No.</b>	<b>Description</b>	<b>Bit Value</b>	<b>Value Description</b>				
[7:2]	Not used.	-	-				



**Address (hex): 66 (cont...)**

<b>Register Name</b>	<i>cnfg_T4_DPLL_bw</i>	<b>Description</b>	(R/W) Register to configure the bandwidth of the T4 DPLL.	<b>Default Value</b>	0000 0000		
<b>Bit 7</b>	<b>Bit 6</b>	<b>Bit 5</b>	<b>Bit 4</b>	<b>Bit 3</b>	<b>Bit 2</b>	<b>Bit 1</b>	<b>Bit 0</b>
						<i>T4_DPLL_bandwidth</i>	
<b>Bit No.</b>	<b>Description</b>	<b>Bit Value</b>	<b>Value Description</b>				
[1:0]	<i>T4_DPLL_bandwidth</i> Register to configure the bandwidth of the T4 DPLL.	00	T4 DPLL 18 Hz bandwidth.				
		01	T4 DPLL 35 Hz bandwidth.				
		10	T4 DPLL 70 Hz bandwidth.				
		11	Not used.				

**Address (hex): 67**

<b>Register Name</b>	<i>cnfg_T0_DPLL_locked_bw</i>	<b>Description</b>	(R/W) Register to configure the bandwidth of the T0 DPLL, when phase locked to an input.	<b>Default Value</b>	0000 1101		
<b>Bit 7</b>	<b>Bit 6</b>	<b>Bit 5</b>	<b>Bit 4</b>	<b>Bit 3</b>	<b>Bit 2</b>	<b>Bit 1</b>	<b>Bit 0</b>
						<i>T0_DPLL_locked_bandwidth</i>	
<b>Bit No.</b>	<b>Description</b>	<b>Bit Value</b>	<b>Value Description</b>				
[7:4]	Not used.	-	-				
[3:0]	<i>T0_DPLL_locked_bandwidth</i> Register to configure the bandwidth of the T0 DPLL when locked to an input reference. Reg. 3B Bit 7 is used to control whether this bandwidth is used all of the time or automatically switched to when phase locked.	1000	T0 DPLL 0.1 Hz locked bandwidth.				
		1001	T0 DPLL 0.3 Hz locked bandwidth.				
		1010	T0 DPLL 0.6 Hz locked bandwidth.				
		1011	T0 DPLL 1.2 Hz locked bandwidth.				
		1100	T0 DPLL 2.5 Hz locked bandwidth.				
		1101	T0 DPLL 4 Hz locked bandwidth.				
		1110	T0 DPLL 8 Hz locked bandwidth.				
		1111	T0 DPLL 18 Hz locked bandwidth.				
		0000	T0 DPLL 35 Hz locked bandwidth.				
		0001	T0 DPLL 70 Hz locked bandwidth.				
		All other values	Not used.				

Address (hex): **69**

<b>Register Name</b>	<i>cnfg_T0_DPLL_acq_bw</i>	<b>Description</b>	(R/W) Register to configure the bandwidth of the T0 DPLL, when not phase locked to an input.	<b>Default Value</b>	0000 1111		
<b>Bit 7</b>	<b>Bit 6</b>	<b>Bit 5</b>	<b>Bit 4</b>	<b>Bit 3</b>	<b>Bit 2</b>	<b>Bit 1</b>	<b>Bit 0</b>
				<i>T0_DPLL_acquisition_bandwidth</i>			
<b>Bit No.</b>	<b>Description</b>	<b>Bit Value</b>	<b>Value Description</b>				
[7:4]	Not used.	-	-				
[3:0]	<i>T0_DPLL_acquisition_bandwidth</i> Register to configure the bandwidth of the T0 DPLL when acquiring phase lock on an input reference. Reg. 3B Bit 7 is used to control whether this bandwidth is not used or automatically switched to when not phase locked.	1000 1001 1010 1011 1100 1101 1110 1111 0000 0001	TO DPLL 0.1 Hz acquisition bandwidth. TO DPLL 0.3 Hz acquisition bandwidth. TO DPLL 0.6 Hz acquisition bandwidth. TO DPLL 1.2 Hz acquisition bandwidth. TO DPLL 2.5 Hz acquisition bandwidth. TO DPLL 4 Hz acquisition bandwidth. TO DPLL 8 Hz acquisition bandwidth. TO DPLL 18 Hz acquisition bandwidth. TO DPLL 35 Hz acquisition bandwidth. TO DPLL 70 Hz acquisition bandwidth.				
		All other values	Not used.				

Address (hex): **6A**

<b>Register Name</b>	<i>cnfg_T4_DPLL_damping</i>	<b>Description</b>	(R/W) Register to configure the damping factor of the T4 DPLL, along with the gain of Phase Detector 2 in some modes.	<b>Default Value</b>	0001 0011		
<b>Bit 7</b>	<b>Bit 6</b>	<b>Bit 5</b>	<b>Bit 4</b>	<b>Bit 3</b>	<b>Bit 2</b>	<b>Bit 1</b>	<b>Bit 0</b>
<i>T4_PD2_gain_alog_8k</i>				<i>T4_damping</i>			
<b>Bit No.</b>	<b>Description</b>	<b>Bit Value</b>	<b>Value Description</b>				
7	Not used.	-	-				
[6:4]	<i>T4_PD2_gain_alog_8k</i> Register to control the gain of the Phase Detector 2 when locking to a reference of 8 kHz or less in analog feedback mode. This setting is only used if automatic gain selection is enabled in Reg. 6C Bit 7, <i>cnfg_T4_DPLL_PD2_gain</i> .	-	Gain value of the Phase Detector 2 when locking to an 8 kHz reference in analog feedback mode.				
3	Not used.	-	-				

### Address (hex): 6A (cont...)

<b>Register Name</b>	<i>cnfg_T4_DPLL_damping</i>	<b>Description</b>	(R/W) Register to configure the damping factor of the T4 DPLL, along with the gain of Phase Detector 2 in some modes.			<b>Default Value</b>	0001 0011																																																
<b>Bit 7</b>	<b>Bit 6</b>	<b>Bit 5</b>	<b>Bit 4</b>	<b>Bit 3</b>	<b>Bit 2</b>	<b>Bit 1</b>	<b>Bit 0</b>																																																
	<i>T4_PD2_gain_alog_8k</i>				<i>T4_damping</i>																																																		
<b>Bit No.</b>	<b>Description</b>	<b>Bit Value</b>	<b>Value Description</b>																																																				
[2:0]	<p><i>T4_damping</i> Register to configure the damping factor of the T4 DPLL. The bit values corresponds to different damping factors, depending on the bandwidth selected. Damping factor of 5 being the default (011).</p> <p>The Gain Peak for the Damping Factors given in the Value Description (right) are tabulated below.</p> <table border="1"> <thead> <tr> <th>Damping Factor</th> <th>Gain Peak</th> </tr> </thead> <tbody> <tr> <td>1.2</td> <td>0.4 dB</td> </tr> <tr> <td>2.5</td> <td>0.2 dB</td> </tr> <tr> <td>5</td> <td>0.1 dB</td> </tr> <tr> <td>10</td> <td>0.06 dB</td> </tr> <tr> <td>20</td> <td>0.03 dB</td> </tr> </tbody> </table>	Damping Factor	Gain Peak	1.2	0.4 dB	2.5	0.2 dB	5	0.1 dB	10	0.06 dB	20	0.03 dB		<p><b>T4 DPLL damping factor at the following bandwidths frequency selections:</b></p> <table border="1"> <thead> <tr> <th></th> <th>18 Hz</th> <th>35 Hz</th> <th>70 Hz</th> </tr> </thead> <tbody> <tr> <td>001</td> <td>1.2</td> <td>1.2</td> <td>1.2</td> </tr> <tr> <td>010</td> <td>2.5</td> <td>2.5</td> <td>2.5</td> </tr> <tr> <td>011</td> <td>5</td> <td>5</td> <td>5</td> </tr> <tr> <td>100</td> <td>5</td> <td>10</td> <td>10</td> </tr> <tr> <td>101</td> <td>5</td> <td>10</td> <td>20</td> </tr> <tr> <td>000</td> <td colspan="3">Not used.</td> </tr> <tr> <td>110</td> <td colspan="3">Not used.</td> </tr> <tr> <td>111</td> <td colspan="3">Not used.</td> </tr> </tbody> </table>						18 Hz	35 Hz	70 Hz	001	1.2	1.2	1.2	010	2.5	2.5	2.5	011	5	5	5	100	5	10	10	101	5	10	20	000	Not used.			110	Not used.			111	Not used.		
Damping Factor	Gain Peak																																																						
1.2	0.4 dB																																																						
2.5	0.2 dB																																																						
5	0.1 dB																																																						
10	0.06 dB																																																						
20	0.03 dB																																																						
	18 Hz	35 Hz	70 Hz																																																				
001	1.2	1.2	1.2																																																				
010	2.5	2.5	2.5																																																				
011	5	5	5																																																				
100	5	10	10																																																				
101	5	10	20																																																				
000	Not used.																																																						
110	Not used.																																																						
111	Not used.																																																						

### Address (hex): 6B

<b>Register Name</b>	<i>cnfg_T0_DPLL_damping</i>	<b>Description</b>	(R/W) Register to configure the damping factor of the T0 DPLL, along with the gain of the Phase Detector 2 in some modes.			<b>Default Value</b>	0001 0011
<b>Bit 7</b>	<b>Bit 6</b>	<b>Bit 5</b>	<b>Bit 4</b>	<b>Bit 3</b>	<b>Bit 2</b>	<b>Bit 1</b>	<b>Bit 0</b>
	<i>T0_PD2_gain_alog_8k</i>				<i>T0_damping</i>		
<b>Bit No.</b>	<b>Description</b>	<b>Bit Value</b>	<b>Value Description</b>				
7	Not used.	-	-				
[6:4]	<p><i>T0_PD2_gain_alog_8k</i> Register to control the gain of the Phase Detector 2 when locking to a reference of 8 kHz or less in analog feedback mode. This setting is only used if automatic gain selection is enabled in Reg. 6D Bit 7, <i>cnfg_T0_DPLL_PD2_gain</i>.</p>	-	Gain value of the Phase Detector 2 when locking to an 8 kHz reference in analog feedback mode.				
3	Not used.	-	-				

### Address (hex): 6B (cont...)

<b>Register Name</b>	<i>cnfg_T0_DPLL_damping</i>	<b>Description</b>	(R/W) Register to configure the damping factor of the T0 DPLL, along with the gain of the Phase Detector 2 in some modes.				<b>Default Value</b>	0001 0011																													
<b>Bit 7</b>	<b>Bit 6</b>	<b>Bit 5</b>	<b>Bit 4</b>	<b>Bit 3</b>	<b>Bit 2</b>	<b>Bit 1</b>	<b>Bit 0</b>																														
	<i>T0_PD2_gain_alog_8k</i>				<i>T0_damping</i>																																
<b>Bit No.</b>	<b>Description</b>	<b>Bit Value</b>	<b>Value Description</b>																																		
[2:0]	<i>T0_damping</i> Register to configure the damping factor of the T0 DPLL. The bit values corresponds to different damping factors, depending on the bandwidth selected. Damping factor of 5 being the default (011).  The Gain Peak for the Damping Factors given in the Value Description (right) are tabulated below.		<b>T0 DPLL damping factor at the following bandwidths frequency selections:</b> <table border="1"> <thead> <tr> <th>≤4 Hz</th> <th>8 Hz</th> <th>18 Hz</th> <th>35 Hz</th> <th>70 Hz</th> </tr> </thead> <tbody> <tr> <td>5</td> <td>2.5</td> <td>1.2</td> <td>1.2</td> <td>1.2</td> </tr> <tr> <td>010</td> <td>5</td> <td>2.5</td> <td>2.5</td> <td>2.5</td> </tr> <tr> <td>011</td> <td>5</td> <td>5</td> <td>5</td> <td>5</td> </tr> <tr> <td>100</td> <td>5</td> <td>5</td> <td>10</td> <td>10</td> </tr> <tr> <td>101</td> <td>5</td> <td>5</td> <td>10</td> <td>20</td> </tr> </tbody> </table>					≤4 Hz	8 Hz	18 Hz	35 Hz	70 Hz	5	2.5	1.2	1.2	1.2	010	5	2.5	2.5	2.5	011	5	5	5	5	100	5	5	10	10	101	5	5	10	20
≤4 Hz	8 Hz	18 Hz	35 Hz	70 Hz																																	
5	2.5	1.2	1.2	1.2																																	
010	5	2.5	2.5	2.5																																	
011	5	5	5	5																																	
100	5	5	10	10																																	
101	5	5	10	20																																	
	<table border="1"> <thead> <tr> <th>Damping Factor</th> <th>Gain Peak</th> </tr> </thead> <tbody> <tr> <td>1.2</td> <td>0.4 dB</td> </tr> <tr> <td>2.5</td> <td>0.2 dB</td> </tr> <tr> <td>5</td> <td>0.1 dB</td> </tr> <tr> <td>10</td> <td>0.06 dB</td> </tr> <tr> <td>20</td> <td>0.03 dB</td> </tr> </tbody> </table>	Damping Factor	Gain Peak	1.2	0.4 dB	2.5	0.2 dB	5	0.1 dB	10	0.06 dB	20	0.03 dB	000	Not used.																						
Damping Factor	Gain Peak																																				
1.2	0.4 dB																																				
2.5	0.2 dB																																				
5	0.1 dB																																				
10	0.06 dB																																				
20	0.03 dB																																				
		110	Not used.																																		
		111	Not used.																																		

### Address (hex): 6C

<b>Register Name</b>	<i>cnfg_T4_DPLL_PD2_gain</i>	<b>Description</b>	(R/W) Register to configure the gain of Phase Detector 2 in some modes for the T4 DPLL.				<b>Default Value</b>	1100 0010
<b>Bit 7</b>	<b>Bit 6</b>	<b>Bit 5</b>	<b>Bit 4</b>	<b>Bit 3</b>	<b>Bit 2</b>	<b>Bit 1</b>	<b>Bit 0</b>	
<i>T4_PD2_gain_enable</i>	<i>T4_PD2_gain_alog</i>				<i>T4_PD2_gain_digital</i>			
<b>Bit No.</b>	<b>Description</b>	<b>Bit Value</b>	<b>Value Description</b>					
7	<i>T4_PD2_gain_enable</i>	0	T4 DPLL Phase Detector 2 not used.					
		1	T4 DPLL Phase Detector 2 gain enabled and choice of gain determined according to the locking mode: - digital feedback mode - analog feedback mode - analog feedback at 8 kHz.					

### Address (hex): 6C (cont...)

<b>Register Name</b>	<i>cnfg_T4_DPLL_PD2_gain</i>	<b>Description</b>	(R/W) Register to configure the gain of Phase Detector 2 in some modes for the T4 DPLL.	<b>Default Value</b>	1100 0010		
<b>Bit 7</b>	<b>Bit 6</b>	<b>Bit 5</b>	<b>Bit 4</b>	<b>Bit 3</b>	<b>Bit 2</b>	<b>Bit 1</b>	<b>Bit 0</b>
<i>T4_PD2_gain_enable</i>	<i>T4_PD2_gain_alog</i>				<i>T4_PD2_gain_digital</i>		
<b>Bit No.</b>	<b>Description</b>	<b>Bit Value</b>	<b>Value Description</b>				
[6:4]	<i>T4_PD2_gain_alog</i> Register to control the gain of Phase Detector 2 when locking to a reference, higher than 8 kHz, in analog feedback mode. This setting is not used if automatic gain selection is disabled in Bit 7, <i>T4_PD2_gain_enable</i> .	-	Gain value of Phase Detector 2 when locking to a high frequency reference in analog feedback mode.				
3	Not used.	-	-				
[2:0]	<i>T4_PD2_gain_digital</i> Register to control the gain of Phase Detector 2 when locking to a reference in digital feedback mode. This setting is always used if automatic gain selection is disabled in Bit 7, <i>T4_PD2_gain_enable</i> .	-	Gain value of Phase Detector 2 when locking to any reference in digital feedback mode.				

### Address (hex): 6D

<b>Register Name</b>	<i>cnfg_T0_DPLL_PD2_gain</i>	<b>Description</b>	(R/W) Register to configure the gain of Phase Detector 2 in some modes for the T0 DPLL.	<b>Default Value</b>	1100 0010		
<b>Bit 7</b>	<b>Bit 6</b>	<b>Bit 5</b>	<b>Bit 4</b>	<b>Bit 3</b>	<b>Bit 2</b>	<b>Bit 1</b>	<b>Bit 0</b>
<i>T0_PD2_gain_enable</i>	<i>T0_PD2_gain_alog</i>				<i>T0_PD2_gain_digital</i>		
<b>Bit No.</b>	<b>Description</b>	<b>Bit Value</b>	<b>Value Description</b>				
7	<i>T0_PD2_gain_enable</i>	0 1	T0 DPLL Phase Detector 2 not used. T0 DPLL Phase Detector 2 gain enabled and choice of gain determined according to the locking mode: - digital feedback mode - analog feedback mode - analog feedback at 8 kHz.				
[6:4]	<i>T0_PD2_gain_alog</i> Register to control the gain of Phase Detector 2 when locking to a reference, higher than 8 kHz, in analog feedback mode. This setting is not used if automatic gain selection is disabled in Bit 7, <i>T0_PD2_gain_enable</i> .	-	Gain value of Phase Detector 2 when locking to a high frequency reference in analog feedback mode.				
3	Not used.	-	-				

### Address (hex): 6D (cont...)

<b>Register Name</b>	<i>cnfg_T0_DPLL_PD2_gain</i>	<b>Description</b>	(R/W) Register to configure the gain of Phase Detector 2 in some modes for the T0 DPLL.	<b>Default Value</b>	1100 0010		
<b>Bit 7</b>	<b>Bit 6</b>	<b>Bit 5</b>	<b>Bit 4</b>	<b>Bit 3</b>	<b>Bit 2</b>	<b>Bit 1</b>	<b>Bit 0</b>
<i>TO_PD2_gain_enable</i>	<i>TO_PD2_gain_alog</i>				<i>TO_PD2_gain_digital</i>		
<b>Bit No.</b>	<b>Description</b>	<b>Bit Value</b>	<b>Value Description</b>				
[2:0]	<i>TO_PD2_gain_digital</i> Register to control the gain of Phase Detector 2 when locking to a reference in digital feedback mode. This setting is always used if automatic gain selection is disabled in Bit 7, <i>TO_PD2_gain_enable</i> .	-	Gain value of Phase Detector 2 when locking to any reference in digital feedback mode.				

### Address (hex): 70

<b>Register Name</b>	<i>cnfg_phase_offset [7:0]</i>	<b>Description</b>	(R/W) Bits [7:0] of the phase offset control register.	<b>Default Value</b>	0000 0000		
<b>Bit 7</b>	<b>Bit 6</b>	<b>Bit 5</b>	<b>Bit 4</b>	<b>Bit 3</b>	<b>Bit 2</b>	<b>Bit 1</b>	<b>Bit 0</b>
<i>phase_offset_value[7:0]</i>							
<b>Bit No.</b>	<b>Description</b>	<b>Bit Value</b>	<b>Value Description</b>				
[7:0]	<i>phase_offset_value[7:0]</i> Register forming part of the phase offset control.	-	See Reg. 71, <i>cnfg_phase_offset[15:8]</i> for more details.				

### Address (hex): 71

<b>Register Name</b>	<i>cnfg_phase_offset</i> [15:8]	<b>Description</b>	(R/W) Bits [15:8] of the phase offset control register.	<b>Default Value</b>	0000 0000		
<b>Bit 7</b>	<b>Bit 6</b>	<b>Bit 5</b>	<b>Bit 4</b>	<b>Bit 3</b>	<b>Bit 2</b>	<b>Bit 1</b>	<b>Bit 0</b>
<i>phase_offset_value[15:8]</i>							
<b>Bit No.</b>	<b>Description</b>	<b>Bit Value</b>	<b>Value Description</b>				
[7:0]	<i>phase_offset_value[15:8]</i> Register forming part of the phase offset control. If the phase offset register is written to when the DPLL is locked to an input, then it is possible that some internal signals become out of synchronization. In order to avoid this, the phase offset is automatically "ramped" to the new value. If the phase offset is only ever adjusted when the device is in Holdover, then this is not necessary, and this automatic "ramping" can be disabled, see Reg. 7C, <i>cnfg_sync_monitor</i> .  This register is ignored and has no affect when Phase Build-out is enabled in either Reg. 48 or Reg. 76.	-	The value in this register is to be concatenated with the contents of Reg. 70 <i>cnfg_phase_offset</i> [7:0]. This value is a 16-bit 2's complement signed number. The value multiplied by 6.279 represents the extent of the applied phase offset in picoseconds.  The phase offset register is not a control to a "traditional" delay line. This number 6.279 actually represents a fractional portion of the period of an internal 77.76 MHz cycle and can, therefore, be represented more accurately as follows. Each bit value of the register represents the period of the internal 77.76 MHz clock divided by 2 <sup>11</sup> . If, for example, the DPLL is locked to a reference that is +1 ppm in frequency with respect to a perfect oscillator, then the period, and hence the phase offset, will be decreased by 1 ppm. Programming a value of 1024 into the phase offset register will produce a complete inversion of the 77.76 MHz output clock.  <i>Note...The exact period of the internal 77.76 MHz clock is determined by the current state of the DPLL i.e. in Locked mode its accuracy depends on that of the locked to input, in Holdover or Free-run it depends on the accuracy of the external oscillator.</i>				

### Address (hex): 72

<b>Register Name</b>	<i>cnfg_PBO_phase_offset</i>	<b>Description</b>	(R/W) Register to offset the mean time error of Phase Build-out events.	<b>Default Value</b>	0000 0000		
<b>Bit 7</b>	<b>Bit 6</b>	<b>Bit 5</b>	<b>Bit 4</b>	<b>Bit 3</b>	<b>Bit 2</b>	<b>Bit 1</b>	<b>Bit 0</b>
<i>PBO_phase_offset</i>							
<b>Bit No.</b>	<b>Description</b>	<b>Bit Value</b>	<b>Value Description</b>				
[7:6]	Not used.	-	-				

### Address (hex): 72 (cont...)

<b>Register Name</b>	<i>cnfg_PBO_phase_offset</i>	<b>Description</b>	(R/W) Register to offset the mean time error of Phase Build-out events.	<b>Default Value</b>	0000 0000		
<b>Bit 7</b>	<b>Bit 6</b>	<b>Bit 5</b>	<b>Bit 4</b>	<b>Bit 3</b>	<b>Bit 2</b>	<b>Bit 1</b>	<b>Bit 0</b>
<i>PBO_phase_offset</i>							
<b>Bit No.</b>	<b>Description</b>	<b>Bit Value</b>	<b>Value Description</b>				
[5:0]	<i>PBO_phase_offset</i> Each time a Phase Build-out event is triggered, there is an uncertainty of up to 5 ns introduced which translates to a phase hit on the output. The mean error over a large number of events is designed to be zero. This register can be used to introduce a fixed offset into each PBO event. This will have the effect of moving the mean error positive or negative in time.	-	The value in this register is a 6-bit 2's complement number. The value multiplied by 0.101 gives the programmed offset in nanoseconds. Values greater than +1.4 ns or less than -1.4 ns should NOT be used as they may cause internal mathematical errors.				

### Address (hex): 73

<b>Register Name</b>	<i>cnfg_phase_loss_fine_limit</i>	<b>Description</b>	(R/W) Register to configure some of the parameters of the TO DPLL phase detector.	<b>Default Value</b>	1010 0010		
<b>Bit 7</b>	<b>Bit 6</b>	<b>Bit 5</b>	<b>Bit 4</b>	<b>Bit 3</b>	<b>Bit 2</b>	<b>Bit 1</b>	<b>Bit 0</b>
<i>fine_limit_en</i>	<i>noact_ph_loss</i>	<i>narrow_en</i>			<i>phase_loss_fine_limit</i>		
<b>Bit No.</b>	<b>Description</b>	<b>Bit Value</b>	<b>Value Description</b>				
7	<i>fine_limit_en</i> Register bit to enable the <i>phase_loss_fine_limit</i> Bits [2:0]. When disabled, phase lock/loss is determined by the other means within the device. This must be disabled when multi-UI jitter tolerance is required, see Reg. 74, <i>cnfg_phase_loss_course_limit</i> .	0 1	Phase loss indication only triggered by other means. Phase loss triggered when phase error exceeds the limit programmed in <i>phase_loss_fine_limit</i> , Bits [2:0].				
6	<i>noact_ph_loss</i> The DPLL detects that an input has failed very rapidly. Normally, when the DPLL detects this condition, it does not consider phase lock to be lost and will phase lock to the nearest edge ( $\pm 180^\circ$ ) when a source becomes available again, hence giving tolerance to missing cycles. If phase loss is indicated, then frequency and phase locking is instigated ( $\pm 360^\circ$ locking). This bit can be used to force the DPLL to indicate phase loss immediately when no activity is detected.	0 1	No activity on reference does not trigger phase lost indication. No activity triggers phase lost indication.				



### Address (hex): 73 (cont...)

<b>Register Name</b>	<i>cnfg_phase_loss_fine_limit</i>			<b>Description</b>	(R/W) Register to configure some of the parameters of the TO DPLL phase detector.	<b>Default Value</b>	1010 0010
<b>Bit 7</b>	<b>Bit 6</b>	<b>Bit 5</b>	<b>Bit 4</b>	<b>Bit 3</b>	<b>Bit 2</b>	<b>Bit 1</b>	<b>Bit 0</b>
<i>fine_limit_en</i>	<i>noact_ph_loss</i>	<i>narrow_en</i>			<i>phase_loss_fine_limit</i>		
<b>Bit No.</b>	<b>Description</b>			<b>Bit Value</b>	<b>Value Description</b>		
5	<i>narrow_en</i> (test control bit) Set to 1 (default value)			0 1	Do not use. Indicates phase loss continuously. Set to 1		
[4:3]	Not used.			-	-		
[2:0]	<i>phase_loss_fine_limit</i> When enabled by Bit 7, this register coarsely sets the phase limit at which the device indicates phase lost or locked. The default value of 2 (010) gives a window size of around $\pm 90^\circ$ - $180^\circ$ . The phase position of the inputs to the DPLL has to be within the window limit for 1 - 2 seconds before the device indicates phase lock. If it is outside the window for any time then phase loss is immediately indicated. For most cases the default value of 2 (010) is satisfactory. The window size changes in proportion to the value, so a value of 1 (001) will give a narrow phase acceptance or lock window of approximately $\pm 45^\circ$ - $90^\circ$ .			000 001 010 011 100 101 110 111	Do not use. Indicates phase loss continuously. Small phase window for phase lock indication. Recommended value. ) ) ) Larger phase window for phase lock indication. ) )		

### Address (hex): 74

<b>Register Name</b>	<i>cnfg_phase_loss_coarse_limit</i>			<b>Description</b>	(R/W) Register to configure some of the parameters of the TO DPLL phase detector.	<b>Default Value</b>	1000 0101
<b>Bit 7</b>	<b>Bit 6</b>	<b>Bit 5</b>	<b>Bit 4</b>	<b>Bit 3</b>	<b>Bit 2</b>	<b>Bit 1</b>	<b>Bit 0</b>
<i>coarse_lim_phase_loss_en</i>	<i>wide_range_en</i>	<i>multi_ph_resp</i>			<i>phase_loss_coarse_limit</i>		
<b>Bit No.</b>	<b>Description</b>			<b>Bit Value</b>	<b>Value Description</b>		
7	<i>coarse_lim_phase_loss_en</i> Register bit to enable the coarse phase detector, whose range is determined by <i>phase_loss_coarse_limit</i> Bits [3:0]. This register sets the limit in the number of input clock cycles (UI) that the input phase can move by before the DPLL indicates phase lost.			0 1	Phase loss not triggered by the coarse phase lock detector. Phase loss triggered when phase error exceeds the limit programmed in <i>phase_loss_coarse_limit</i> , Bits [3:0].		

Address (hex): **74** (cont...)

<b>Register Name</b>	<i>cnfg_phase_loss_coarse_limit</i>			<b>Description</b>	(R/W) Register to configure some of the parameters of the TO DPLL phase detector.	<b>Default Value</b>	1000 0101
<b>Bit 7</b>	<b>Bit 6</b>	<b>Bit 5</b>	<b>Bit 4</b>	<b>Bit 3</b>	<b>Bit 2</b>	<b>Bit 1</b>	<b>Bit 0</b>
<i>coarse_lim_phase_loss_en</i>	<i>wide_range_en</i>	<i>multi_ph_resp</i>			<i>phase_loss_coarse_limit</i>		
<b>Bit No.</b>	<b>Description</b>	<b>Bit Value</b>	<b>Value Description</b>				
6	<i>wide_range_en</i> To enable the device to be tolerant to large amounts of applied jitter and still do direct phase locking at the input frequency rate (up to 77.76 MHz), a wide range phase detector and phase lock detector is employed. This bit enables the wide range phase detector. This allows the device to be tolerant to, and therefore keep track of, drifts in input phase of many cycles (UI). The range of the phase detector is set by the same register used for the phase loss coarse limit (Bits [3:0]).	0 1	Wide range phase detector off. Wide range phase detector on.				
5	<i>multi_ph_resp</i> Enables the phase result from the coarse phase detector to be used in the DPLL algorithm. Bit 6 should also be set when this is activated. The coarse phase detector can measure and keep track over many thousands of input cycles, thus allowing excellent jitter and wander tolerance. This bit enables that phase result to be used in the DPLL algorithm, so that a large phase measurement gives a faster pull-in of the DPLL. If this bit is not set then the phase measurement is limited to $\pm 360^\circ$ which can give a slower pull-in rate at higher input frequencies, but could also be used to give less overshoot. Setting this bit in direct locking mode, for example with a 19.44 MHz input, would give the same dynamic response as a 19.44 MHz input used with 8 k locking mode, where the input is divided down internally to 8 kHz first.	0 1	DPLL phase detector limited to $\pm 360^\circ$ ( $\pm 1$ UI). However it will still remember its original phase position over many thousands of UI if Bit 6 is set. DPLL phase detector also uses the full coarse phase detector result. It can now measure up to: $\pm 360^\circ \times 8191$ UI = $\pm 2,948,760^\circ$ .				
4	Not used.	-	-				

### Address (hex): 74 (cont...)

<b>Register Name</b>	<i>cnfg_phase_loss_coarse_limit</i>			<b>Description</b>	(R/W) Register to configure some of the parameters of the T0 DPLL phase detector.	<b>Default Value</b>	1000 0101
<b>Bit 7</b>	<b>Bit 6</b>	<b>Bit 5</b>	<b>Bit 4</b>	<b>Bit 3</b>	<b>Bit 2</b>	<b>Bit 1</b>	<b>Bit 0</b>
<i>coarse_lim_phase_loss_en</i>	<i>wide_range_en</i>	<i>multi_ph_resp</i>			<i>phase_loss_coarse_limit</i>		
<b>Bit No.</b>	<b>Description</b>		<b>Bit Value</b>	<b>Value Description</b>			
[3:0]	<i>phase_loss_coarse_limit</i> Sets the range of the coarse phase loss detector and the coarse phase detector. When locking to a high frequency signal, and jitter tolerance greater than 0.5 UI is required, then the DPLL can be configured to track phase errors over many input clock periods. This is particularly useful with very low bandwidths. This register configures how many UI over which the input phase can be tracked. It also sets the range of the coarse phase loss detector, which can be used with or without the multi-UI phase capture range capability. This register value is used by Bits 6 and 7.		0000 0001 0010 0011 0100 0101 0110 0111 1000 1001 1010 1011 1100-1111	Input phase error tracked over $\pm 1$ UI. Input phase error tracked over $\pm 3$ UI. Input phase error tracked over $\pm 7$ UI. Input phase error tracked over $\pm 15$ UI. Input phase error tracked over $\pm 31$ UI. Input phase error tracked over $\pm 63$ UI. Input phase error tracked over $\pm 127$ UI. Input phase error tracked over $\pm 255$ UI. Input phase error tracked over $\pm 511$ UI. Input phase error tracked over $\pm 1023$ UI. Input phase error tracked over $\pm 2047$ UI. Input phase error tracked over $\pm 4095$ UI. Input phase error tracked over $\pm 8191$ UI.			

### Address (hex): 76

<b>Register Name</b>	<i>cnfg_phasemon</i>			<b>Description</b>	(R/W) Register to configure the noise rejection function for low frequency inputs.	<b>Default Value</b>	0000 0110
<b>Bit 7</b>	<b>Bit 6</b>	<b>Bit 5</b>	<b>Bit 4</b>	<b>Bit 3</b>	<b>Bit 2</b>	<b>Bit 1</b>	<b>Bit 0</b>
<i>ip_noise_window</i>							
<b>Bit No.</b>	<b>Description</b>		<b>Bit Value</b>	<b>Value Description</b>			
7	<i>ip_noise_window</i> Register bit to enable a window of 5% tolerance around low-frequency inputs (2, 4 and 8 kHz). This feature ensures that any edge caused by noise outside the 5% window where the edge is expected will not be considered within the DPLL. This reduces any possible phase hit when a low-frequency connection is removed and contact bounce is possible.		0 1	DPLL considers all edges for phase locking. DPLL ignores input edges outside a 95% to 105% window.			
[6:0]	Not used.		-	-			

### Address (hex): 77

<b>Register Name</b>	<i>sts_current_phase</i> [7:0]	<b>Description</b>	(RO) Bits [7:0] of the current phase register.	<b>Default Value</b>	0000 0000		
<b>Bit 7</b>	<b>Bit 6</b>	<b>Bit 5</b>	<b>Bit 4</b>	<b>Bit 3</b>	<b>Bit 2</b>	<b>Bit 1</b>	<b>Bit 0</b>
<i>current_phase</i> [7:0]							
<b>Bit No.</b>	<b>Description</b>	<b>Bit Value</b>	<b>Value Description</b>				
[7:0]	<i>current_phase</i> Bits [7:0] of the current phase register. See Reg. 78 <i>sts_current_phase</i> [15:8] for details.	-	See Reg. 78 <i>sts_current_phase</i> [15:8] for details.				

### Address (hex): 78

<b>Register Name</b>	<i>sts_current_phase</i> [15:8]	<b>Description</b>	(RO) Bits [15:8] of the current phase register.	<b>Default Value</b>	0000 0000		
<b>Bit 7</b>	<b>Bit 6</b>	<b>Bit 5</b>	<b>Bit 4</b>	<b>Bit 3</b>	<b>Bit 2</b>	<b>Bit 1</b>	<b>Bit 0</b>
<i>current_phase</i> [15:8]							
<b>Bit No.</b>	<b>Description</b>	<b>Bit Value</b>	<b>Value Description</b>				
[7:0]	<i>current_phase</i> Bits [15:8] of the current phase register. This register is used to read either from the phase detector of either the T0 DPLL or the T4 DPLL, according to Reg. 4B Bit 4 <i>T4_TO_select</i> . The value is averaged in the phase averager (filter with approx. 100 Hz bandwidth) before being made available.	-	The value in this register should be concatenated with the value in Reg. 77 <i>sts_current_phase</i> [7:0]. This 16-bit value is a 2's complement signed integer. The value multiplied by 0.707 is the averaged value of the current phase error, in degrees, as measured at the DPLL's phase detector.				

### Address (hex): 79

<b>Register Name</b>	<i>cnfg_phase_alarm_timeout</i>	<b>Description</b>	(RO) Register to configure how long before a phase alarm is raised on an input	<b>Default Value</b>	0011 0010		
<b>Bit 7</b>	<b>Bit 6</b>	<b>Bit 5</b>	<b>Bit 4</b>	<b>Bit 3</b>	<b>Bit 2</b>	<b>Bit 1</b>	<b>Bit 0</b>
		<i>timeout_value</i>					
<b>Bit No.</b>	<b>Description</b>	<b>Bit Value</b>	<b>Value Description</b>				
[7:6]	Not used.	-	-				

### Address (hex): 79 (cont...)

<b>Register Name</b>	<i>cnfg_phase_alarm_timeout</i>	<b>Description</b>	(RO) Register to configure how long before a phase alarm is raised on an input	<b>Default Value</b>	0011 0010		
<b>Bit 7</b>	<b>Bit 6</b>	<b>Bit 5</b>	<b>Bit 4</b>	<b>Bit 3</b>	<b>Bit 2</b>	<b>Bit 1</b>	<b>Bit 0</b>
<i>timeout_value</i>							
<b>Bit No.</b>	<b>Description</b>	<b>Bit Value</b>	<b>Value Description</b>				
[5:0]	<i>timeout_value</i> Phase alarms can only be raised on an input when the T0 DPLL is attempting to lock to it. Once an input has been rejected due to a phase alarm, there is no way to measure whether it is good again, because it is no longer selected by the DPLL. The phase alarms can either remain until reset by software, or timeout after 128 second, as selected in Reg. 34 Bit 6, <i>phalarm_timeout</i>	-	This 6-bit unsigned integer represents the length of time before a phase alarm will be raised on an input. The value multiplied by 2 gives the time in seconds. This time value is the time that the controlling state machine will spend in Pre-locked, Pre-locked2 or Phase-lost modes before setting the phase alarm on the selected input.				

### Address (hex): 7A

<b>Register Name</b>	<i>cnfg_sync_pulses</i>	<b>Description</b>	(R/W) Register to configure the Sync outputs, and select the source for the 2 kHz and 8 kHz outputs from O1 to O4.	<b>Default Value</b>	0000 0000		
<b>Bit 7</b>	<b>Bit 6</b>	<b>Bit 5</b>	<b>Bit 4</b>	<b>Bit 3</b>	<b>Bit 2</b>	<b>Bit 1</b>	<b>Bit 0</b>
<i>2k_8k_from_T4</i>				<i>8k_invert</i>	<i>8k_pulse</i>	<i>2k_invert</i>	<i>2k_pulse</i>
<b>Bit No.</b>	<b>Description</b>	<b>Bit Value</b>	<b>Value Description</b>				
7	<i>2k_8k_from_T4</i> Register to select the source (T0 or T4) for the 2 kHz and 8 kHz outputs available from O1 to O4.	0 1	2/8 kHz on O1 to O4 generated from the T0 DPLL. 2/8 kHz on O1 to O4 generated from the T4 DPLL.				
[6:4]	Not used.	-	-				
3	<i>8k_invert</i> Register bit to invert the 8 kHz output from FrSync.	0 1	8 kHz FrSync output not inverted. 8 kHz FrSync output inverted.				
2	<i>8k_pulse</i> Register bit to enable the 8 kHz output from FrSync to be either pulsed or 50:50 duty cycle. Output O3 must be enabled to use "pulsed output" mode on the FrSync output, and then the pulse width on the FrSync output will be equal to the period of the output programmed on O3.	0 1	8 kHz FrSync output not pulsed. 8 kHz FrSync output pulsed.				
1	<i>2k_invert</i> Register bit to invert the 2 kHz output from MFrSync.	0 1	2 kHz MFrSync output not inverted. 2 kHz MFrSync output inverted.				

### Address (hex): 7A (cont...)

<b>Register Name</b>	<i>cnfg_sync_pulses</i>	<b>Description</b>	(R/W) Register to configure the Sync outputs, and select the source for the 2 kHz and 8 kHz outputs from O1 to O4.				<b>Default Value</b>	0000 0000
<b>Bit 7</b>	<b>Bit 6</b>	<b>Bit 5</b>	<b>Bit 4</b>	<b>Bit 3</b>	<b>Bit 2</b>	<b>Bit 1</b>	<b>Bit 0</b>	
<i>2k_8k_from_T4</i>				<i>8k_invert</i>	<i>8k_pulse</i>	<i>2k_invert</i>	<i>2k_pulse</i>	
<b>Bit No.</b>	<b>Description</b>	<b>Bit Value</b>	<b>Value Description</b>					
0	<i>2k_pulse</i> Register bit to enable the 2 kHz output from MFrSync to be either pulsed or 50:50 duty cycle. Output O3 must be enabled to use "pulsed output" mode on the MFrSync output, and then the pulse width on the MFrSync output will be equal to the period of the output programmed on O3.	0 1	2 kHz MFrSync output not pulsed. 2 kHz MFrSync output pulsed.					

### Address (hex): 7B

<b>Register Name</b>	<i>cnfg_sync_phase</i>	<b>Description</b>	(R/W) Register to configure the behavior of the synchronization for the external frame reference.				<b>Default Value</b>	0000 0000
<b>Bit 7</b>	<b>Bit 6</b>	<b>Bit 5</b>	<b>Bit 4</b>	<b>Bit 3</b>	<b>Bit 2</b>	<b>Bit 1</b>	<b>Bit 0</b>	
<i>indep_FrSync/ MFrSync</i>	<i>Sync_OC-N_ rates</i>					<i>Sync_phase</i>		
<b>Bit No.</b>	<b>Description</b>	<b>Bit Value</b>	<b>Value Description</b>					
7	<i>indep_FrSync/MFrSync</i> This allows the option of either maintaining alignment of FrSync and other clock outputs during synchronization from the SYNC2K input, or whether to not maintain alignment to all clocks and so not disturb any of the output clocks	0 1	MFrSync & FrSync outputs are always aligned with other output clocks. MFrSync & FrSync outputs are independent of other output clocks.					
6	<i>Sync_OC-N_rates</i> This allows the SYNC2K input to synchronize the OC-3 derived clocks in order to maintain alignment between the FrSync output and output clocks and allow a finer sampling precision of the SYNC2K input of either 19.44 MHz or 38.88 MHz.	0 1	The OC-N rate clocks are not affected by the SYNC2K input. The SYNC2K input is sampled with a 6.48 MHz precision. 6.48MHz should be provided as the input reference clock. Allows the SYNC2K to operate with a 19.44 MHz or 38.88 MHz input clock reference. Input sampling and output alignment to 19.44 MHz is used when the current clock input is 19.44 MHz, otherwise 38.88 MHz sampling precision is used.					
[5:2]	Not used.							

### Address (hex): 7B (cont...)

<b>Register Name</b>	<i>cnfg_sync_phase</i>		<b>Description</b>	(R/W) Register to configure the behavior of the synchronization for the external frame reference.		<b>Default Value</b>	0000 0000
<b>Bit 7</b>	<b>Bit 6</b>	<b>Bit 5</b>	<b>Bit 4</b>	<b>Bit 3</b>	<b>Bit 2</b>	<b>Bit 1</b>	<b>Bit 0</b>
<i>indep_FrSync/ MFrSync</i>	<i>Sync_OC-N_ rates</i>					<i>Sync_phase</i>	
<b>Bit No.</b>	<b>Description</b>		<b>Bit Value</b>	<b>Value Description</b>			
[1:0]	<i>Sync_phase</i> Register to control the sampling of the external Sync input. Nominally the falling edge of the input is aligned with the falling edge of the reference clock. The margin is $\pm 0.5$ U.I. (Unit Interval).		00	On target.			
			01	0.5 U.I. early			
			10	1 U.I. late			
			11	0.5 U.I. late.			

### Address (hex): 7C

<b>Register Name</b>	<i>cnfg_sync_monitor</i>		<b>Description</b>	(R/W) Register to control the phase offset automatic ramping feature.		<b>Default Value</b>	0010 1011
<b>Bit 7</b>	<b>Bit 6</b>	<b>Bit 5</b>	<b>Bit 4</b>	<b>Bit 3</b>	<b>Bit 2</b>	<b>Bit 1</b>	<b>Bit 0</b>
<i>ph_offset_ramp</i>							
<b>Bit No.</b>	<b>Description</b>		<b>Bit Value</b>	<b>Value Description</b>			
7	<i>ph_offset_ramp</i> Register bit to force an internal phase offset calibration, see Reg. 71, <i>Cnfg_Phase_Offset</i> . The calibration routine is transparent to the User and puts the device in holdover while it internally ramps the phase offset to zero, resets all internal output and feedback dividers and then ramps the phase offset to the current programmed value from Reg. 70 or 71., holdover is then turned off. Throughout this procedure, no change in output phase offset is visible.		0	Phase offset automatically ramped from the old value to the new value when there is a change in Reg. 70 or 71.			
			1	Start phase offset internal calibration routine. This bit is reset to 0 when this is complete.			
[6:0]	Not used.		-	-			

Address (hex): **7D**

<b>Register Name</b>	<i>cnfg_interrupt</i>	<b>Description</b>	(R/W) Register to configure interrupt output.	<b>Default Value</b>	0000 0010		
<b>Bit 7</b>	<b>Bit 6</b>	<b>Bit 5</b>	<b>Bit 4</b>	<b>Bit 3</b>	<b>Bit 2</b>	<b>Bit 1</b>	<b>Bit 0</b>
				<i>GPO_en</i>	<i>tristate_en</i>	<i>int_polarity</i>	
<b>Bit No.</b>	<b>Description</b>	<b>Bit Value</b>	<b>Value Description</b>				
[7:3]	Not used.	-	-				
2	<i>GPO_en</i> (Interrupt General Purpose Output). If the interrupt output pin is not required, then setting this bit will allow the pin to be used as a general purpose output. The pin will be driven to the state of the polarity control bit, <i>int_polarity</i> .	0 1	Interrupt output pin used for interrupts. Interrupt output pin used for GPO purpose.				
1	<i>tristate_en</i> The interrupt can be configured to be either connected directly to a processor, or wired together with other sources.	0 1	Interrupt pin always driven when inactive. Interrupt pin only driven when active, high-impedance when inactive.				
0	<i>int_polarity</i> The interrupt pin can be configured to be active <i>High</i> or <i>Low</i> .	0 1	Active <i>Low</i> - pin driven <i>Low</i> to indicate active interrupt. Active <i>High</i> - pin driven <i>High</i> to indicate active interrupt.				

Address (hex): **7E**

<b>Register Name</b>	<i>cnfg_protection</i>	<b>Description</b>	(R/W) Protection register to protect against erroneous software writes.	<b>Default Value</b>	1000 0101		
<b>Bit 7</b>	<b>Bit 6</b>	<b>Bit 5</b>	<b>Bit 4</b>	<b>Bit 3</b>	<b>Bit 2</b>	<b>Bit 1</b>	<b>Bit 0</b>
<i>protection_value</i>							
<b>Bit No.</b>	<b>Description</b>	<b>Bit Value</b>	<b>Value Description</b>				
[7:0]	<i>protection_value</i> This register can be used to ensure that the software writes a specific value to this register, before being able to modify any other register in the device. Three modes of protection are offered, (i) protected (ii) fully unprotected (iii) single unprotected. When protected, no other register in the device can be written to. When fully unprotected, any writeable register in the device can be written to. When single unprotected, only one register can be written before the device automatically re-protects itself.	0000 0000 – 1000 0100 1000 0101 1000 0110 1000 0111 – 1111 1111	Protected mode. Fully unprotected. Single unprotected. Protected mode.				



### Electrical Specifications

#### JTAG

The JTAG connections on the ACS8522A allow a full boundary scan to be made. The JTAG implementation is fully compliant to IEEE 1149.1<sup>[5]</sup>, with the following minor exceptions, and the user should refer to the standard for further information.

1. The output boundary scan cells do not capture data from the core, and so do not support INTEST. However this does not affect board testing.
2. In common with some other manufacturers, pin TRST is internally pulled *Low* to disable JTAG by default. The standard is to pull *High*. The polarity of TRST is as the standard: TRST *High* to enable JTAG boundary scan mode, TRST *Low* for normal operation.

The JTAG timing diagram is shown in Figure 14.

Figure 14 JTAG Timing

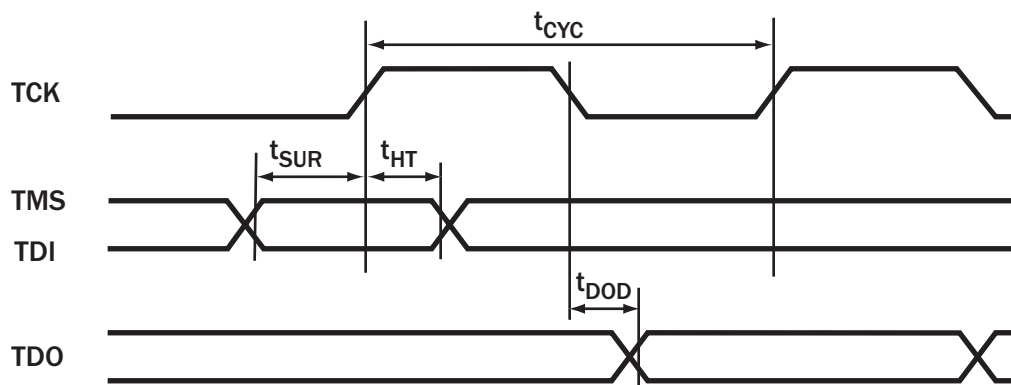

F8110D\_022JTAGTiming\_01

Table 21 JTAG Timing (for use with Figure 14)

Parameter	Symbol	Minimum	Typical	Maximum	Units
Cycle Time	$t_{CYC}$	50	-	-	ns
TMS/TDI to TCK rising edge time	$t_{SUR}$	3	-	-	ns
TCK rising to TMS/TDI hold time	$t_{HT}$	23	-	-	ns
TCK falling to TDO valid	$t_{DOD}$	-	-	5	ns

#### Over-voltage Protection

The ACS8522A may require Over-Voltage Protection on input reference clock ports according to ITU recommendation K.41<sup>[16]</sup>. Semtech protection devices are recommended for this purpose (see separate Semtech data book).

#### ESD Protection

Suitable precautions should be taken to protect against electrostatic damage during handling and assembly. This device incorporates ESD protection structures that protect the device against ESD damage at ESD input levels up to at least  $\pm 2\text{kV}$  using the Human Body Model (HBM) MIL-STD-883D Method 3015.7, for all pins.

#### Latchup Protection

This device is protected against latchup for input current pulses of magnitude up to at least  $\pm 100\text{ mA}$  to JEDEC Standard No. 78 August 1997.

## Maximum Ratings

Important Note: The Absolute Maximum Ratings, Table 22, are stress ratings only, and functional operation of the device at conditions other than those indicated in the Operating Conditions sections of this specification are not implied. Exposure to the absolute maximum ratings for an extended period may reduce the reliability or useful lifetime of the product.

**Table 22 Absolute Maximum Ratings**

Parameter	Symbol	Minimum	Maximum	Units
Supply Voltage VDD1, VDD2, VDD3, VDD4, VDD5, VDD6, VDD7, VD1+, VD2+, VD3+, VA1+, VA2+, VA3+, VDD_DIFF	V <sub>DD</sub>	-0.5	3.6	V
Input Voltage (non-supply pins)	V <sub>IN</sub>	-	3.6	V
Output Voltage (non-supply pins)	V <sub>OUT</sub>	-	3.6	V
Ambient Operating Temperature Range	T <sub>A</sub>	0	+70	°C
Storage Temperature	T <sub>STOR</sub>	-50	+150	°C

## Operating Conditions

**Table 23 Operating Conditions**

Parameter	Symbol	Minimum	Typical	Maximum	Units
Power Supply (dc voltage) VDD1, VDD2, VDD3, VDD4, VDD5, VDD6, VDD7, VD1+, VD2+, VD3+, VA1+, VA2+, VA3+, VDD_DIFF	V <sub>DD</sub>	3.135	3.3	3.465	V
Ambient Temperature Range	T <sub>A</sub>	0	-	+70	°C
Supply Current (Typical - one 19 MHz output)	I <sub>DD</sub>	-	110	200	mA
Total Power Dissipation	P <sub>TOT</sub>	-	360	720	mW

## DC Characteristics

**Table 24 DC Characteristics: TTL Input Port**

Across all operating conditions, unless otherwise stated

Parameter	Symbol	Minimum	Typical	Maximum	Units
V <sub>IN High</sub>	V <sub>IH</sub>	2	-	-	V
V <sub>IN Low</sub>	V <sub>IL</sub>	-	-	0.8	V
Input Current	I <sub>IN</sub>	-	-	10	μA

**Table 25 DC Characteristics: TTL Input Port with Internal Pull-up**

Across all operating conditions, unless otherwise stated

Parameter	Symbol	Minimum	Typical	Maximum	Units
$V_{IN\ High}$	$V_{IH}$	2	-	-	V
$V_{IN\ Low}$	$V_{IL}$	-	-	0.8	V
Pull-up Resistor	PU	25	-	95	k $\Omega$
Input Current	$I_{IN}$	-	-	120	$\mu$ A

**Table 26 DC Characteristics: TTL Input Port with Internal Pull-down**

Across all operating conditions, unless otherwise stated

Parameter	Symbol	Minimum	Typical	Maximum	Units
$V_{IN\ High}$	$V_{IH}$	2	-	-	V
$V_{IN\ Low}$	$V_{IL}$	-	-	0.8	V
Pull-down Resistor (except TCK input)	PD	25	-	95	k $\Omega$
Pull-down Resistor (TCK input only)	PD	12.5	-	47.5	k $\Omega$
Input Current	$I_{IN}$	-	-	120	$\mu$ A

**Table 27 DC Characteristics: TTL Output Port**

Across all operating conditions, unless otherwise stated

Parameter	Symbol	Minimum	Typical	Maximum	Units
$V_{OUT\ Low}$ ( $I_{OL} = 4\text{ mA}$ )	$V_{OL}$	0	-	0.4	V
$V_{OUT\ High}$ ( $I_{OL} = 4\text{ mA}$ )	$V_{OH}$	2.4	-	-	V
Drive Current	ID	-	-	4	mA

**Table 28 DC Characteristics: PECL Output Port**

Across all operating conditions, unless otherwise stated

Parameter	Symbol	Minimum	Typical	Maximum	Units
PECL Output Low Voltage (Note (i))	$V_{OLPECL}$	$V_{DD}-2.10$	-	$V_{DD}-1.62$	V
PECL Output High Voltage (Note (i))	$V_{OHPECL}$	$V_{DD}-1.25$	-	$V_{DD}-0.88$	V
PECL Output Differential Voltage (Note (i))	$V_{ODPECL}$	580	-	900	mV

 Note: (i) With 50  $\Omega$  load on each pin to  $V_{DD}-2\text{ V}$ , i.e. 82  $\Omega$  to GND and 130  $\Omega$  to  $V_{DD}$ .

**Figure 15 Recommended Line Termination for PECL Output Ports**

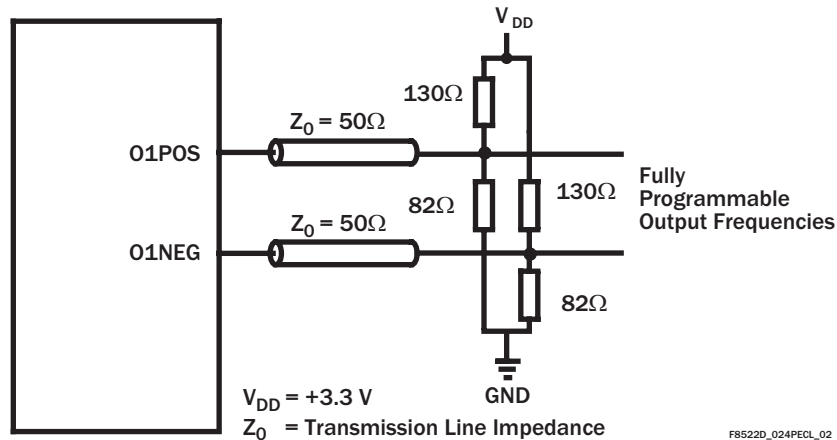

**Table 29 DC Characteristics: LVDS Output Port**

Across all operating conditions, unless otherwise stated

Parameter	Symbol	Minimum	Typical	Maximum	Units
LVDS Output High Voltage (Note (i))	$V_{OHLVDS}$	-	-	1.585	V
LVDS Output Low Voltage (Note (i))	$V_{OLLVDS}$	0.885	-	-	V
LVDS Differential Output Voltage	$V_{ODLVDS}$	250	-	450	mV
LVDS Change in Magnitude of Differential Output Voltage for complementary States (Note (i))	$V_{DOSLVDS}$	-	-	25	mV
LVDS Output Offset Voltage Temperature = 25°C (Note (i))	$V_{OSLVDS}$	1.125	-	1.275	V

Note: (i) With 100 Ω load between the differential outputs.

**Figure 16 Recommended Line Termination for LVDS Output Port**

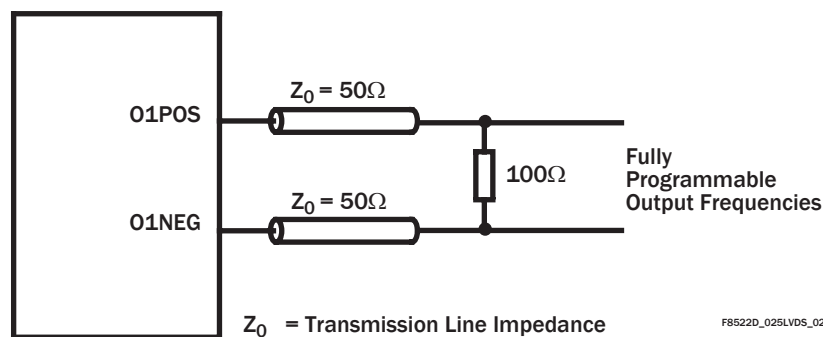

## Jitter Performance

Output jitter generation measured over 60 second interval, UI pk-pk max measured using C-MAC E2747 12.800 MHz TCXO on ICT Flexacom tester.

**Table 30 Output Jitter Generation**

Test Definition		Conditions			Jitter Spec	ACS8522A Jitter
Specification	Filter	Bandwidth	I/P Freq	Lock Mode	UI	UI (TYP)
G813 <sup>[11]</sup> for 155 MHz o/p option 1	65 kHz - 1.3 MHz	4 Hz	19 MHz	Direct lock	0.1 pk-pk	0.067 pk-pk
				8k lock		0.065 pk-pk
G813 <sup>[11]</sup> & G812 <sup>[10]</sup> for 2.048 MHz option 1	20 Hz - 100 kHz	4 Hz	2.048 MHz	8k lock	0.05 pk-pk	0.012 pk-pk
G813 <sup>[11]</sup> for 155 MHz o/p option 2	12 kHz - 1.3 MHz	18 Hz	19 MHz	Direct lock/ 8k lock	0.1 pk-pk	0.072 pk-pk
	12 kHz - 1.3 MHz	8 Hz	19 MHz	Direct lock/ 8k lock	0.1 pk-pk	0.072 pk-pk
	12 kHz - 1.3 MHz	4 Hz	19 MHz	Direct lock/ 8k lock	0.1 pk-pk	0.078 pk-pk
	12 kHz - 1.3 MHz	2.5 Hz	19 MHz	Direct lock/ 8k lock	0.1 pk-pk	0.078 pk-pk
	12 kHz - 1.3 MHz	1.2 Hz	19 MHz	Direct lock/ 8k lock	0.1 pk-pk	0.078 pk-pk
	12 kHz - 1.3 MHz	0.6 Hz	19 MHz	Direct lock/ 8k lock	0.1 pk-pk	0.076 pk-pk
G812 <sup>[10]</sup> for 1.544 MHz o/p	10 Hz - 40 kHz	4 Hz	1.544 MHz	8k lock	0.05 pk-pk	0.006 pk-pk
G812 <sup>[10]</sup> for 155 MHz electrical	500 Hz - 1.3 MHz	4 Hz	19 MHz	8k lock	0.5 pk-pk	0.118 pk-pk
G812 <sup>[10]</sup> for 155 MHz electrical	65 kHz - 1.3 MHz	4 Hz	19 MHz	8k lock	0.075 pk-pk	0.065 pk-pk
ETS-300-462-3 <sup>[3]</sup> for 2.048 MHz SEC o/p	20 Hz - 100 kHz	4 Hz	2.048 MHz	8k lock	0.5 pk-pk	0.012 pk-pk
ETS-300-462-3 <sup>[3]</sup> for 2.048 MHz SEC o/p	49 Hz - 100 kHz	4 Hz	2.048 MHz	8k lock	0.2 pk-pk	0.012 pk-pk
ETS-300-462-3 <sup>[3]</sup> for 2.048 MHz SSU o/p	20 Hz - 100 kHz	4 Hz	2.048 MHz	8k lock	0.05 pk-pk	0.012 pk-pk
ETS-300-462-5 <sup>[4]</sup> for 155 MHz o/p	500 Hz - 1.3 MHz	4 Hz	19 MHz	8k lock	0.5 pk-pk	0.118 pk-pk
ETS-300-462-5 <sup>[4]</sup> for 155 MHz o/p	65 kHz - 1.3 MHz	4 Hz	19 MHz	8k lock	0.1 pk-pk	0.067 pk-pk
GR-253-CORE <sup>[17]</sup> net i/f, 51.84 MHz o/p	100 Hz - 0.4 MHz	4 Hz	19 MHz	8k lock	1.5 pk-pk	0.027 pk-pk
GR-253-CORE <sup>[17]</sup> net i/f, 51.84 MHz o/p	20 kHz to 0.4 MHz	4 Hz	19 MHz	8k lock	0.15 pk-pk	0.017 pk-pk
GR-253-CORE <sup>[17]</sup> net i/f, 155 MHz o/p	500 Hz - 1.3 MHz	4 Hz	19 MHz	8k lock	1.5 pk-pk	0.118 pk-pk
GR-253-CORE <sup>[17]</sup> net i/f, 155 MHz o/p	65 kHz - 1.3 MHz	4 Hz	19 MHz	8k lock	0.15 pk-pk	0.067 pk-pk
GR-253-CORE <sup>[17]</sup> cat II elect i/f, 155 MHz	12 kHz - 1.3 MHz	4 Hz	19 MHz	8k lock	0.1 pk-pk	0.076 pk-pk
					0.01 rms	0.006 rms

**Table 30 Output Jitter Generation**

Test Definition		Conditions			Jitter Spec	ACS8522A Jitter
Specification	Filter	Bandwidth	I/P Freq	Lock Mode	UI	UI (TYP)
GR-253-CORE <sup>[17]</sup> cat II elect i/f, 51.84 MHz	12 kHz - 400 kHz	4 Hz	19 MHz	8k lock	0.1 pk-pk	0.018 pk-pk
					0.01 rms	0.003 rms
GR-253-CORE <sup>[17]</sup> DS1 i/f, 1.544 MHz	10 Hz - 40 kHz	4 Hz	1.544 MHz	8k lock	0.1 pk-pk	0.001 pk-pk
					0.01 rms	<0.001 rms
AT&T 62411 <sup>[2]</sup> for 1.544 MHz	10 Hz - 8 kHz	4 Hz	1.544 MHz	8k lock	0.02 rms	<0.001 rms
AT&T 62411 <sup>[2]</sup> for 1.544 MHz	8 Hz - 40 kHz	4 Hz	1.544 MHz	8k lock	0.025 rms	<0.001 rms
AT&T 62411 <sup>[2]</sup> for 1.544 MHz	10 Hz - 40 kHz	4 Hz	1.544 MHz	8k lock	0.025 rms	<0.001 rms
AT&T 62411 <sup>[2]</sup> for 1.544 MHz	Broadband	4 Hz	1.544 MHz	8k lock	0.05 rms	<0.001 rms
G-742 <sup>[8]</sup> for 2.048 MHz	DC - 100 kHz	4 Hz	2.048 MHz	8k lock	0.25 rms	0.012 rms
G-742 <sup>[8]</sup> for 2.048MHz	18 kHz - 100 kHz	4 Hz	2.048 MHz	8k lock	0.05 pk-pk	0.012 pk-pk
G-736 <sup>[7]</sup> for 2.048MHz	20 Hz - 100 kHz	4 Hz	2.048 MHz	8k lock	0.05 pk-pk	0.012 pk-pk
GR-499-CORE <sup>[18]</sup> & G824 <sup>[14]</sup> for 1.544 MHz	10 Hz - 40kHz	4 Hz	1.544 MHz	8k lock	5.0 pk-pk	0.006 pk-pk
GR-499-CORE <sup>[18]</sup> & G824 <sup>[14]</sup> for 1.544 MHz	8 kHz - 40kHz	4 Hz	1.544 MHz	8k lock	0.1 pk-pk	0.006 pk-pk
GR-1244-CORE <sup>[19]</sup> for 1.544 MHz	> 10 Hz	4 Hz	1.544 MHz	8k lock	0.05 pk-pk	0.006 pk-pk

Note...This table is only for comparing the ACS8522A output jitter performance against values and quoted in various specifications for given conditions. It should not be used to infer compliance to any other aspects of these specifications.

### Input/Output Timing

Figure 17 Input/Output Timing with Phase Build-out Off

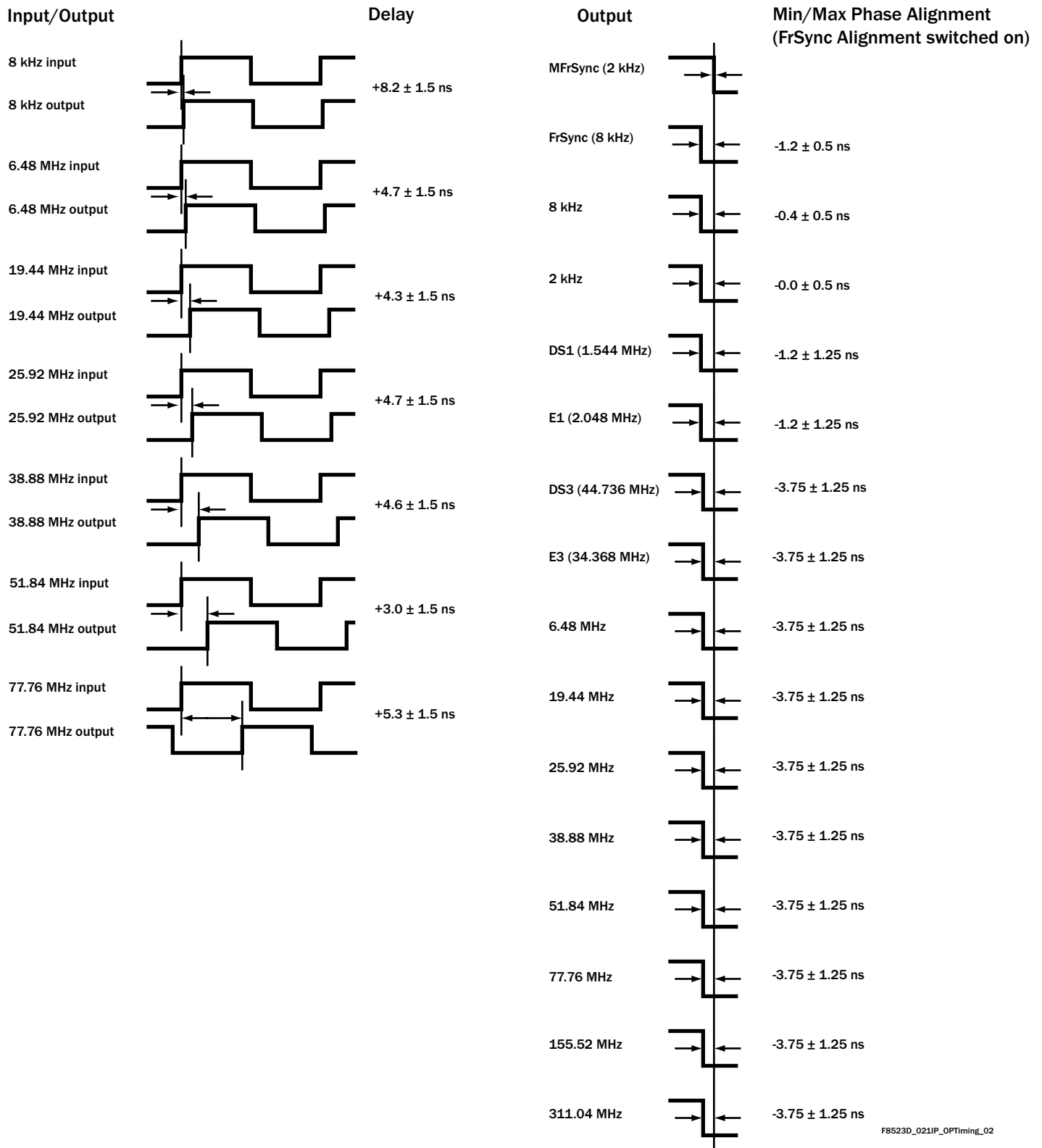

F8523D\_021IP\_OPTiming\_02

### Package Information

Figure 18 LQFP Package

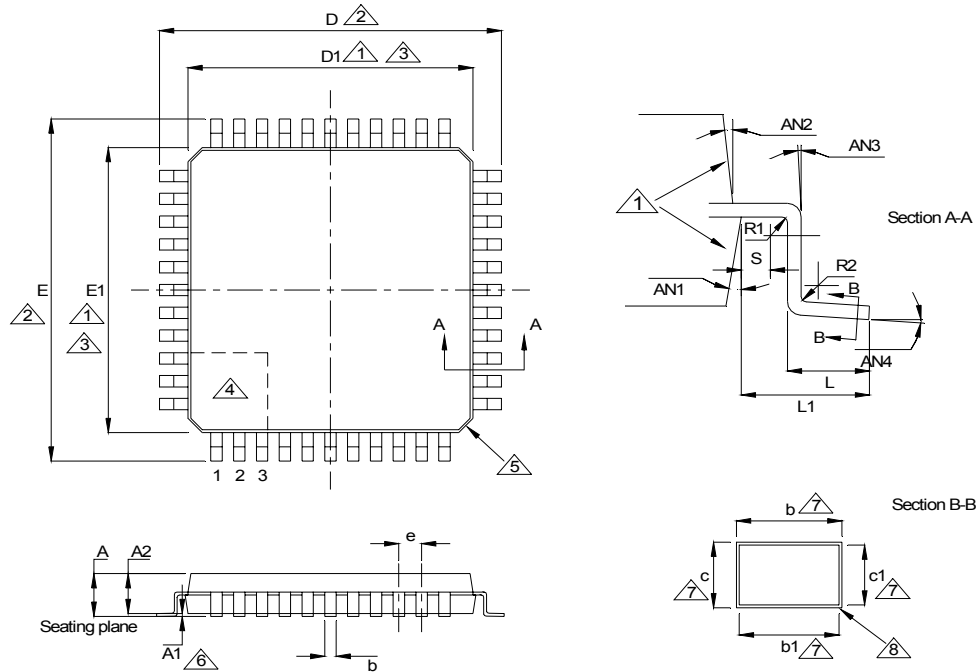

Notes

- ① The top package body may be smaller than the bottom package body by as much as 0.15 mm.
- ② To be determined at seating plane.
- ③ Dimensions D1 and E1 do not include mold protrusion. Allowable protrusion is 0.25 mm per side. D1 and E1 are maximum plastic body size dimensions including mold mismatch.
- ④ Details of pin 1 identifier are optional but will be located within the zone indicated.
- ⑤ Exact shape of corners can vary.
- ⑥ A1 is defined as the distance from the seating plane to the lowest point of the package body.
- ⑦ These dimensions apply to the flat section of the lead between 0.10 mm and 0.25 mm from the lead tip.
- ⑧ Shows plating.

Table 31 64 Pin LQFP Package Dimension Data (for use with Figure 18)

Dimensions in mm	D/E	D1/E1	A	A1	A2	e	AN1	AN2	AN3	AN4	R1	R2	L	L1	S	b	b1	c	c1
Min.	-	-	1.40	0.05	1.35	-	11°	11°	0°	0°	0.08	0.08	0.45	-	0.20	0.17	0.17	0.09	0.09
Nom.	12.00	10.00	1.50	0.10	1.40	0.50	12°	12°	-	3.5°	-	-	0.60	1.00 (ref)	-	0.22	0.20	-	-
Max.	-	-	1.60	0.15	1.45	-	13°	13°	-	7°	-	0.20	0.75	-	-	0.27	0.23	0.20	0.16



**Thermal Conditions**

The device is rated for full temperature range when this package is used with a 4 layer or more PCB. Copper coverage must exceed 50%. All pins must be soldered to the PCB. Maximum operating temperature must be reduced when the device is used with a PCB with less than these requirements.

**Figure 19 Typical 64 Pin LQFP Footprint**

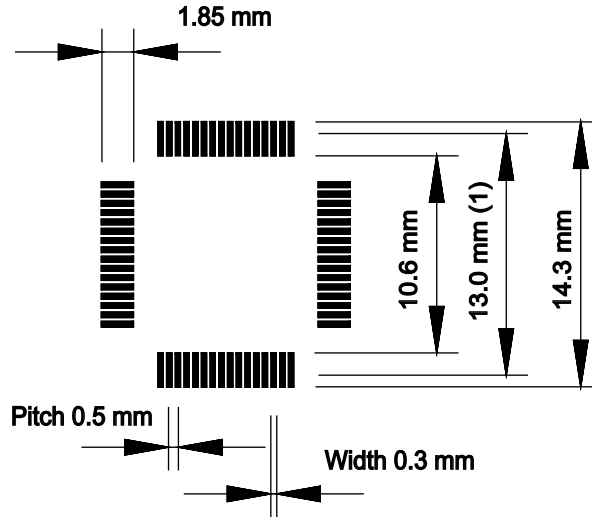

F8525D\_029LQFootprt64

- Notes: (i) Solderable to this limit.  
 (ii) Square package - dimensions apply in both X and Y directions.  
 (iii) Typical example. The user is responsible for ensuring compatibility with PCB manufacturing process, etc.

### Application Information

Figure 20 Simplified Application Schematic

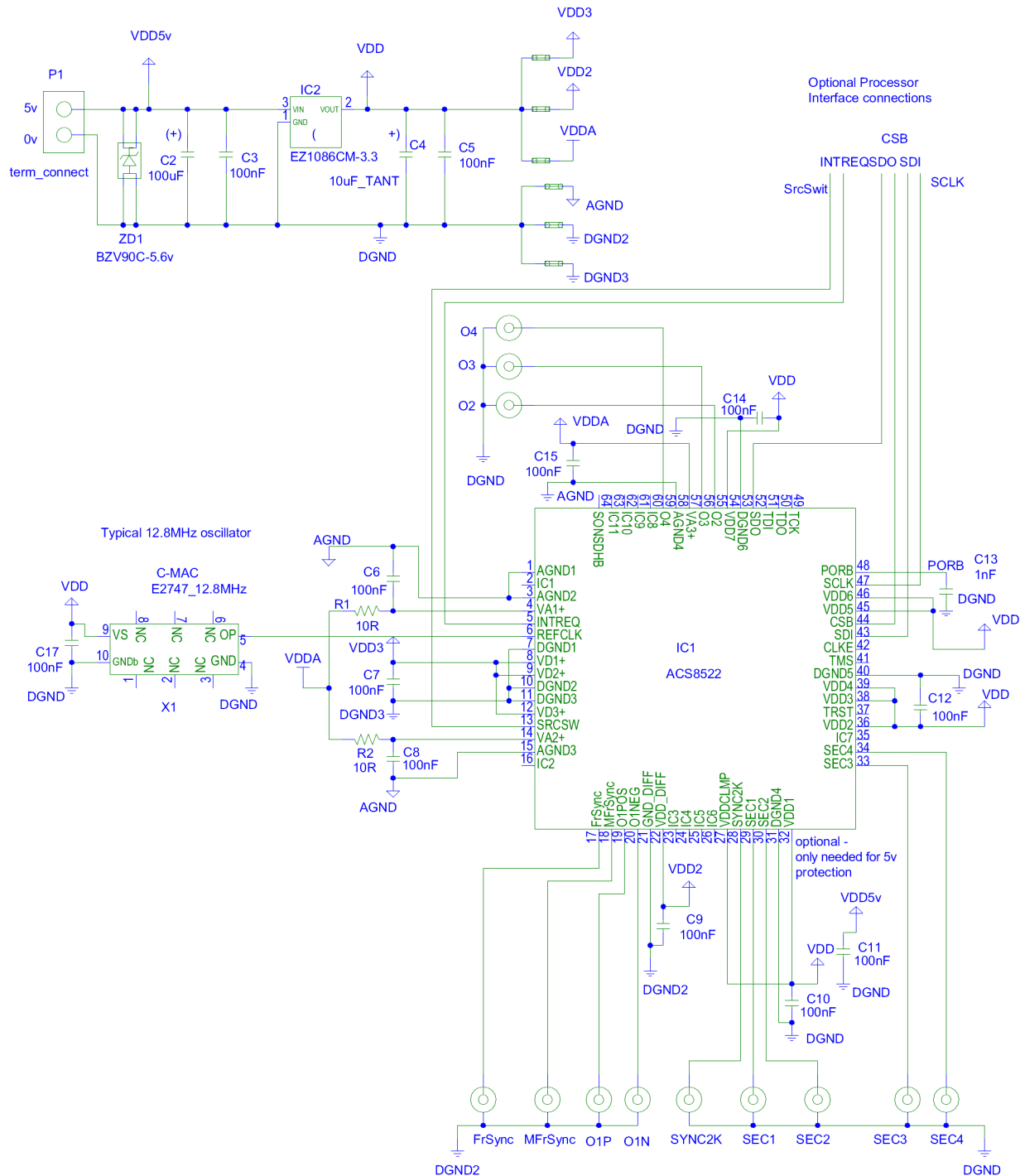

**Abbreviations**
**References**

APLL	Analogue Phase Locked Loop	[1] ANSI T1.101-1999 (1999) Synchronization Interface Standard
BITS	Building Integrated Timing Supply	
DFS	Digital Frequency Synthesis	[2] AT & T 62411 (12/1990) ACCUNET® T1.5 Service description and Interface Specification
DPLL	Digital Phase Locked Loop	
DS1	1544 kbit/s interface rate	
DTO	Discrete Time Oscillator	[3] ETSI ETS 300 462-3, (01/1997) Transmission and Multiplexing (TM); Generic requirements for synchronization networks; Part 3: The control of jitter and wander within synchronization networks
E1	2048 kbit/s interface rate	
I/O	Input - Output	
LOS	Loss Of Signal	
LQFP	Low profile Quad Flat Pack	
LVDS	Low Voltage Differential Signal	[4] ETSI ETS 300 462-5 (09/1996) Transmission and Multiplexing (TM); Generic requirements for synchronization networks; Part 5: Timing characteristics of slave clocks suitable for operation in Synchronous Digital Hierarchy (SDH) equipment
MTIE	Maximum Time Interval Error	
NE	Network Element	
OEXO	Oven Controlled Crystal Oscillator	
PBO	Phase Build-out	
PDH	Plesiochronous Digital Hierarchy	[5] IEEE 1149.1 (1990) Standard Test Access Port and Boundary-Scan Architecture
PECL	Positive Emitter Coupled Logic	
PFD	Phase and Frequency Detector	
PLL	Phase Locked Loop	[6] ITU-T G.703 (10/1998) Physical/electrical characteristics of hierarchical digital interfaces
POR	Power-On Reset	
ppb	parts per billion	
ppm	parts per million	[7] ITU-T G.736 (03/1993) Characteristics of a synchronous digital multiplex equipment operating at 2048 kbit/s
pk-pk	peak-to-peak	
rms	root-mean-square	
RO	Read Only	[8] ITU-T G.742 (1988) Second order digital multiplex equipment operating at 8448 kbit/s, and using positive justification
R/W	Read/Write	
SDH	Synchronous Digital Hierarchy	
SEC	SDH/SONET Equipment Clock	[9] ITU-T G.783 (10/2000) Characteristics of synchronous digital hierarchy (SDH) equipment functional blocks
SETS	Synchronous Equipment Timing source	
SONET	Synchronous Optical Network	
SSU	Synchronization Supply Unit	[10] ITU-T G.812 (06/1998) Timing requirements of slave clocks suitable for use as node clocks in synchronization networks
STM	Synchronous Transport Module	
TDEV	Time Deviation	
TCXO	Temperature Compensated Crystal Oscillator	[11] ITU-T G.813 (08/1996) Timing characteristics of SDH equipment slave clocks (SEC)
UI	Unit Interval	
XO	Crystal Oscillator	[12] ITU-T G.822 (11/1988) Controlled slip rate objectives on an international digital connection
		[13] ITU-T G.823 (03/2000) The control of jitter and wander within digital networks which are based on the 2048 kbit/s hierarchy

[14] ITU-T G.824 (03/2000)

The control of jitter and wander within digital networks which are based on the 1544 kbit/s hierarchy

[15] ITU-T G.825 (03/2000)

The control of jitter and wander within digital networks which are based on the Synchronous Digital Hierarchy (SDH)

[16] ITU-T K.41 (05/1998)

Resistability of internal interfaces of telecommunication centres to surge overvoltages

[17] Telcordia GR-253-CORE, Issue 3 (09/ 2000)  
Synchronous Optical Network (SONET) Transport Systems: Common Generic Criteria

[18] Telcordia GR-499-CORE, Issue 2 (12/1998)  
Transport Systems Generic Requirements (TSGR)  
Common requirements

[19] Telcordia GR-1244-CORE, Issue 2 (12/2000)  
Clocks for the Synchronized Network: Common Generic Criteria

## Trademark Acknowledgements

Semtech and the Semtech S logo are registered trademarks of Semtech Corporation.

ACCUNET® is a registered trademark of AT & T.

C-MAC is a registered trademark of C-MAC MicroTechnology - a division of Solectron Corporation.

ICT Flexacom is a registered trademark of ICT Electronics.

Motorola is a registered trademark of Motorola, Inc.

Telcordia is a registered trademark of Telcordia Technologies.



## Ordering Information

Table 33 Parts List

Part Number	Description
ACS8522A	SETS LITE Synchronous Equipment Timing Source for Stratum 3/4E/4 and SMC Systems
ACS8522AT	Lead (Pb)-free version available (ACS8522AT), RoHS and WEEE compliant.

**Disclaimers**

Life support- This product is not designed or intended for use in life support equipment, devices or systems, or other critical applications, and is not authorized or warranted for such use.

Right to change- Changes may be made to this product without notice. Customers are advised to obtain the latest version of the relevant information before placing orders.

Compliance to relevant standards- Operation of this device is subject to the User's implementation and design practices. It is the responsibility of the User to ensure equipment using this device is compliant to any relevant standards.

**Contacts**

## Semtech Corporation Advanced Communications &amp; Sensing Products

	E-mail: <a href="mailto:sales@semtech.com">sales@semtech.com</a>	<a href="mailto:acsupport@semtech.com">acsupport@semtech.com</a>	Internet: <a href="http://www.semtech.com">http://www.semtech.com</a>
<b>USA</b>	200 Flynn Road, Camarillo, CA 93012-8790. Tel: +1 805 498 2111 Fax: +1 805 498 3804		
<b>FAR EAST</b>	12F, No. 89 Sec. 5, Nanking E. Road, Taipei, 105, TWN, R.O.C. Tel: +886 2 2748 3380 Fax: +886 2 2748 3390		
<b>EUROPE</b>	Semtech Ltd., Units 2 & 3, Park Court, Premier Way, Abbey Park Industrial Estate, Romsey, Hampshire, SO51 9DN. Tel: +44 (0)1794 527 600 Fax: +44 (0)1794 527 601		