



---

## 4-bit DAC, Simple PWM Power Regulator With Linear Controller

### ■ FEATURES

- Switching Regulator and Low Dropout Linear Regulator on Single Chip.
- Simple Voltage-Mode PWM Control.
- Fast Transient Response.
- $\pm 1.5\%$  4-Bit Digital-to-Analog Output Voltage.
- Adjustable Current Limit Without External Sense Resistors.
- Full 0% to 100% Duty Ratio.
- 200KHz Free-Running Oscillator Programmable up to 350KHz.
- Power-Good Output Voltage Monitor.
- Short Circuit Protection with Low Short Circuit Output Current.

### ■ APPLICATIONS

- Power Supply for Pentium, Pentium Pro, Power PC, and Alpha Microprocessors.
- High-Power 5V to 3.xV DC/DC Regulators.
- Low-Voltage Distributed Power Supplies.

### ■ DESCRIPTION

The AIC1566 is a high power, high efficiency switching regulator controller optimized for high performance microprocessor applications. It is designed to drive an N-channel MOSFET in a standard buck topology. Featuring a low dropout linear regulator and a digitally programmable switching regulator, the AIC1566 includes monitoring and protection capabilities in addition to all the essential PWM control functions.

The internal 4-bit Digital-to-Analog Converter (DAC) adjusts the output voltage from 2.0V to 3.5V in 0.1V increments. The precision reference and voltage-mode control can provide output regulation within  $\pm 1.5\%$  over temperature and line voltage shifts.

The internal oscillator of the AIC1566 free runs at 200KHz and can be adjusted up to 350KHz. The resulting PWM duty ratio ranges from 0% to 100%. The error amplifier features a 11MHz bandwidth and  $6V/\mu S$  slew rate which enables high converter bandwidth for fast transient performance.

The AIC1566 provides adjustable over current and short circuit protections. It senses the output current across the on resistance of the N-channel MOSFET without an external low value sense resistor. It also monitors the output voltage with a window comparator and issues a power good signal when the output is within 10% of the rated output voltage.

## ORDERING INFORMATION

AIC1566 XX

- PACKAGE TYPE  
S: SMALL OUTLINE
- TEMPERATURE RANGE  
C: 0°C~70°C

ORDER NUMBER	PIN CONFIGURATION
AIC1566CS (PLASTIC SO)	TOP VIEW
	OCSET [1] [20] VSEN
	SS [2] [19] RT/OVP
	VID0 [3] [18] VCC
	VID1 [4] [17] BOOT
	VID2 [5] [16] UGATE
	VID3 [6] [15] PHASE
	COMP [7] [14] PGOOD
	FB [8] [13] GND
	CLP [9] [12] LIDRI
CLN [10] [11] VLFB	

## TYPICAL APPLICATION CIRCUIT

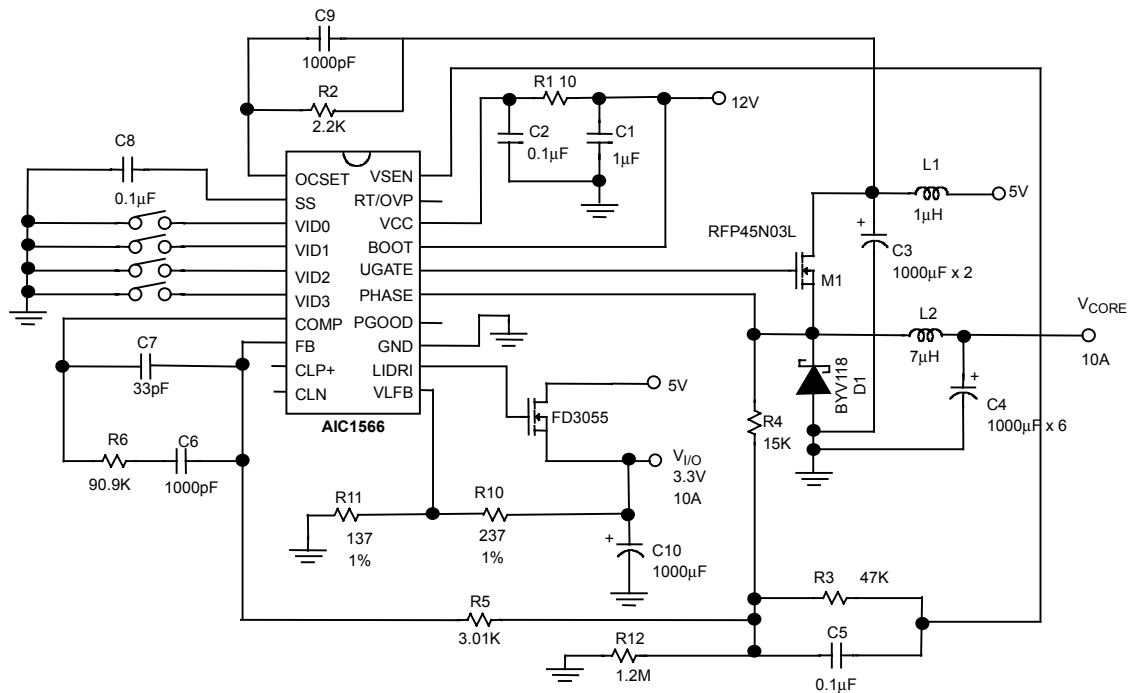

Pentium Pro  $V_{CORE}$  and  $V_{I/O}$  Power Supply

## ■ ABSOLUTE MAXIMUM RATINGS

Supply Voltage, $V_{CC}$ .....	15V
Boot Voltage, $V_{BOOT}$ .....	15V
Input, Output or I/O Voltage .....	GND -0.3V to $V_{CC}+0.3V$
ESD Classification .....	Class 2

### **Recommended Operating Conditions**

Supply Voltage, $V_{CC}$ .....	$12V \pm 10\%$
Ambient Temperature Range .....	$0^{\circ}C \sim 70^{\circ}C$
Junction Temperature Range .....	$0^{\circ}C \sim 100^{\circ}C$

### **Thermal Information**

Thermal Resistance, $\theta_{JA}$ (Typical, Note 1)	
SOIC Package .....	$100^{\circ}C/W$
SOIC Package (with 3 in2 of Copper) .....	$90^{\circ}C/W$
Maximum Junction Temperature (Plastic Package) .....	$150^{\circ}C$
Maximum Storage Temperature Range .....	$-65^{\circ}C \sim 150^{\circ}C$
Maximum Lead Temperature (Soldering 10 sec) .....	$300^{\circ}C$

Note 1:  $\theta_{JA}$  is measured with the component mounted on an evaluation PC board in free air.

## ■ TEST CIRCUIT

Refer to TYPICAL APPLICATION CIRCUIT.

## ■ ELECTRICAL CHARACTERISTICS ( $V_{CC}= 12V$ , $T_a=25^{\circ}C$ , unless otherwise specified.)

PARAMETER	TEST CONDITIONS	SYMBOL	MIN.	TYP.	MAX.	UNIT
<b>VCC Supply Current</b>						
Nominal Supply	UGATE Open	$I_{VCC}$		2		mA
<b>Power-On Reset</b>						
$V_{CC}$ Threshold	$V_{OCSET}=4.5V$			7	8.5	V
Rising $V_{OCSET}$ Threshold				1.26		V
<b>Reference and DAC</b>						
DACOUT Voltage Accuracy			-1.5		+1.5	%
<b>Oscillator</b>						
Free Running Frequency	RT Open		170	200	230	KHz
Total Variation	$6K \leq R_T \leq 200K\Omega$		-20		+20	%
Ramp Amplitude	RT Open	$\Delta V_{OSC}$		1.5		$V_{P-P}$

**ELECTRICAL CHARACTERISTICS (Continued)**

PARAMETER	TEST CONDITIONS	SYMBOL	MIN.	TYP.	MAX.	UNIT
<b>Error Amplifier</b>						
DC Gain				76		dB
Gain-Bandwidth Product		GBW		11		MHz
Slew Rate		SR		6		V/ $\mu$ S
<b>Gate Driver</b>						
Upper Gate Source		$R_{UGATE}$		8	12	$\Omega$
Upper Gate Sink		$R_{UGATE}$		5.5	10	$\Omega$
<b>Protection</b>						
Over-Voltage Trip ( $V_{VSEN} / V_{VDAC}$ )			106	115	125	%
OCSET Current Source	$V_{OCSET}=4.5VDC$	$I_{OCSET}$	170	200	230	$\mu A$
OVP Sourcing Current	$V_{VSEN}=5.5V, V_{OVP}=0V$	$I_{OVP}$	30			mA
SS Current		$I_{SS}$		10		$\mu A$
SS Sink Current under Current Limit	$V_{VSEN}=VDAC, V_{OCSET}=5.0V, V_{PHASE}=0V, V_{FB}=VDAC-50mA$			130		$\mu A$
SS Sink Current under Hard Current Limit	$V_{VSEN}=0, V_{OCSET}=5.0V, V_{PHASE}=0V, V_{FB}=0V$			65		mA
<b>Power Good</b>						
Upper Threshold ( $V_{VSEN} / V_{DAC}$ )	$V_{VSEN}$ Rising		106		114	%
Lower Threshold ( $V_{VSEN} / V_{DAC}$ )	$V_{VSEN}$ Falling		84		94	%
Hysteresis ( $V_{VSEN} / V_{DAC}$ )	Upper and Lower Threshold			2		%
PGOOD Voltage Low	$I_{PGOOD}=5mA$	$V_{PGOOD}$		0.5		V
<b>Linear Regulator</b>						
VLFB Feedback Voltage	Hysteresis ( $V_{VSEN}/V_{DAC}$ )		1.18	1.21	1.24	V
VLFB Bias Current				40		nA
LIDRI Sourcing Current			10			mA
CLP, CLN, Current Limiting Threshold			10	20	30	mV

**BLOCK DIAGRAM**

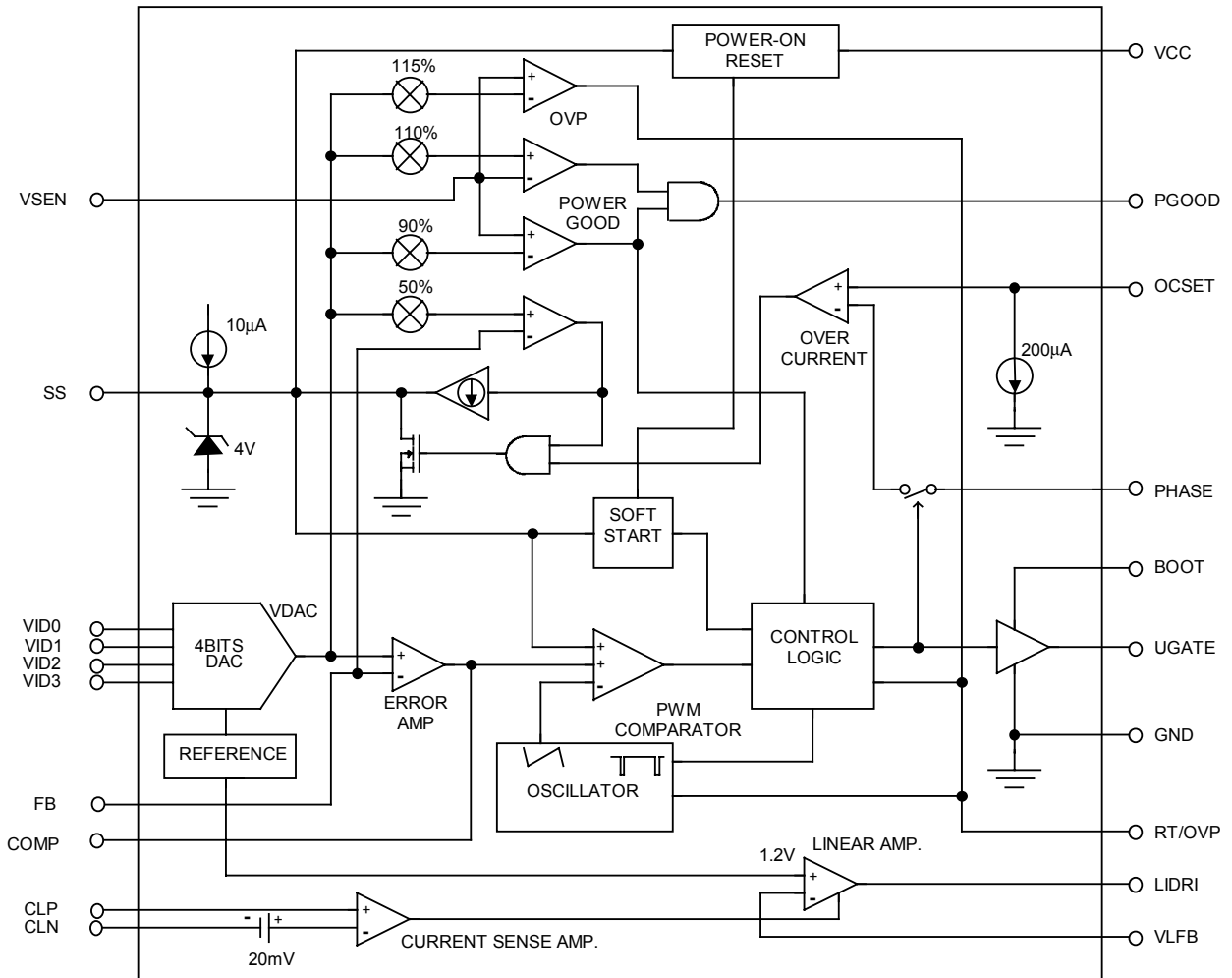

## ■ PIN DESCRIPTION

**PIN 1: OCSET** - Current limit sense pin. Connect a resistor  $R_{OCSET}$  from this pin to the drain of the external MOSFET.  $R_{OCSET}$ , an internal  $200\mu A$  current source ( $I_{OCSET}$ ), and the external MOSFET on-resistance ( $R_{DS(ON)}$ ) jointly set the over current trip point according to the following equation:

$$I_{PEAK} = \frac{I_{OCSET} \times R_{OCSET}}{R_{DS(ON)}}$$

If FB pin voltage is sensed to be below 50% of the internal voltage reference VDAC, the over current comparator cycles the soft-start function.

**PIN 2: SS** - Soft start pin. Connect a capacitor from this pin to ground. An internal  $10\mu A$  current source provides soft start function for the converter.

**PIN 3: VID0**  
**PIN 4: VID1**  
**PIN 5: VID2**  
**PIN 6: VID3**

- 4-bit DAC voltage select pin. TTL inputs used to set the internal voltage reference VDAC. When left open, these pins are internally pulled up to 5V and provide logic ones. The level of VDAC sets the converter output voltage as well as the PGOOD and OVP thresholds.

Table 1 specifies the VDAC voltage for the 16 combinations of DAC inputs.

**PIN 7: COMP** - External compensation pin. This pin is connected to error amplifier output and PWM comparator. An RC network is connected to FB pin to compensate the voltage-control feedback loop of the converter.

**PIN 8: FB** - The error amplifier inverting input pin. The FB pin and COMP pin are used to compensate the voltage-control

feedback loop.

**Table 1. Output Voltage Program**

VID3	VID2	VID1	VID0	VDAC
0	0	0	0	3.5V
0	0	0	1	3.4V
0	0	1	0	3.3V
0	0	1	1	3.2V
0	1	0	0	3.1V
0	1	0	1	3.0V
0	1	1	0	2.9V
0	1	1	1	2.8V
1	0	0	0	2.7V
1	0	0	1	2.6V
1	0	1	0	2.5V
1	0	1	1	2.4V
1	1	0	0	2.3V
1	1	0	1	2.2V
1	1	1	0	2.1V
1	1	1	1	2.0V

**PIN 9: CLP** - Linear regulator current sense pin. This pin is the positive input of the current sense comparator.

**PIN 10: CLN** - Linear regulator current sense pin. This pin is the negative input of the current sense comparator.

**PIN 11: VLFB** - Negative feedback pin for the linear regulator error amplifier.

**PIN 12: LIDRI** - Linear regulator output drive pin. This pin can drive either a Darlington NPN or an N-channel MOSFET.

**PIN 13: GND** - Signal GND. It also serves as the power GND for the upper gate driver.

**PIN 14: PGOOD**-Power good indicator pin. PGOOD is an open drain output. This pin is pulled low when the converter output is 10% out of the VDAC reference voltage.

**PIN 15: PHASE** - Over current detection pin. Connect the PHASE pin to source of the external MOSFET. This pin detects the voltage drop across the MOSFET  $R_{DS(ON)}$  for over-

current protection.

**■ PHYSICAL DIMENSIONS**

- 20 LEAD PLASTIC SO (300 mil) (unit: mm)

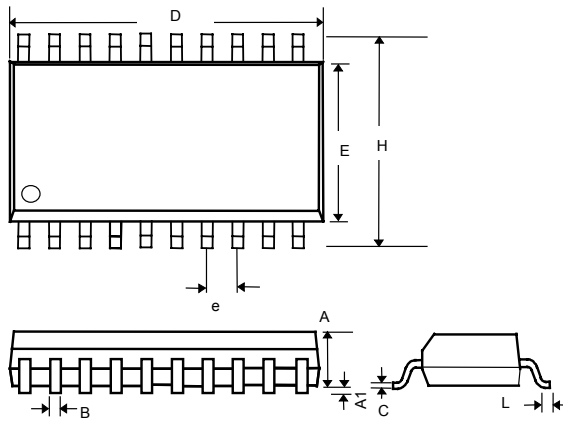

SYMBOL	MIN	MAX
A	2.35	2.65
A1	0.10	0.30
B	0.33	0.51
C	0.23	0.32
D	12.60	13.00
E	7.40	7.60
e	1.27(TYP)	
H	10.00	10.65
L	0.40	1.27