



**Video Enhancement
Processor
AL260 Data Sheets**

Amendments

- 99.10.04 Preliminary version
- 02.12.19 Preliminary version A0.1:
(1) Updated from Preliminary version
- 03.05.16 Version B1.0:
(1) Updated from Preliminary version A0.2
(2) Add Register Description

THE INFORMATION CONTAINED HEREIN IS SUBJECT TO CHANGE WITHOUT NOTICE.

Contents:

1. General Description	5
2. Function Block Diagram	6
3. Features	6
3.1 General Features	6
3.2 Feature Description:	7
4 Applications	8
5 Application Example	9
6 Pin-Out Diagram	10
7 Pin Definition and Description	11
7.1 Input Format Table of AL260:.....	11
8 General Function Description	15
8.1 Function Blocks	15
8.2 VIU (Video Input Unit).....	15
8.2.1 Input Data Format	15
8.2.2 Video Capture and Down Scale Engine	16
8.2.3 Automatic Positioning Registers.....	17
8.2.4 PLL Programming for Memory and Display Clock.....	17
8.3 MIU (Memory Interface Unit).....	17
8.3.1 DRAM Bandwidth Consideration	17
8.3.2 DRAM Input/Output Windows	18
8.3 VPU (Video Processing Unit).....	18
8.4.1 Video De-Interlaced with Film Detection and Motion Adaptive.....	19
8.4.2 Up Scale Engine.....	19
8.4.3 Keystone Up Scale Engine.....	20
8.4 VOU (Video Output Unit).....	20

8.5.1	<i>OSD</i>	22
8.5.2	<i>LUT (Look up table for Gamma Correction and Color Enhancement)</i>	22
8.5.3	<i>Dithering</i>	23
8.5	<i>BIU (Bus Interface Unit)</i>	23
9	<i>Register Definition</i>	24
9.1	<i>Register Set</i>	24
9.2	<i>Register Description</i>	32
10	<i>Electrical Characteristics</i>	76
10.1	<i>Absolute Maximum Ratings</i>	76
10.2	<i>Recommended Operating Conditions</i>	76
10.3	<i>DC Characteristics</i>	76
10.4	<i>AC Characteristics</i>	77
11	<i>Timing Diagrams</i>	78
12	<i>Mechanical Drawing- PQFP-208</i>	79

1. General Description

AL260 is a highly integration Video Enhancement Processor which supports video input with multiple video formats then output with De-interlacing and Scaling effects. It can be used for most video conversion and processing applications.

AL260 is equipped with a high quality scaling engine that automatically maintains full screen output display, regardless of the resolution of the incoming signals. Applying AverLogic's proprietary scaling algorithm, the primary input video can be scaled up and scaled down independently in horizontal & vertical directions. It also provides film detection, advanced de-interlacing, filtering, and scaling which's able to convert and process the interlaced video to be displayed on progressive panels.

The On Screen Display (OSD) window provides overlay of a control menu, text, or caption on the output display. It's built-in OSD generator with 2K Bytes programmable RAM fonts and also supports optional external OSD.

AL260 is built-in 3-channel DAC for non-interlaced analog output and also supports 24bit digital output. It's housed with 208-pin QFP.

2. Function Block Diagram

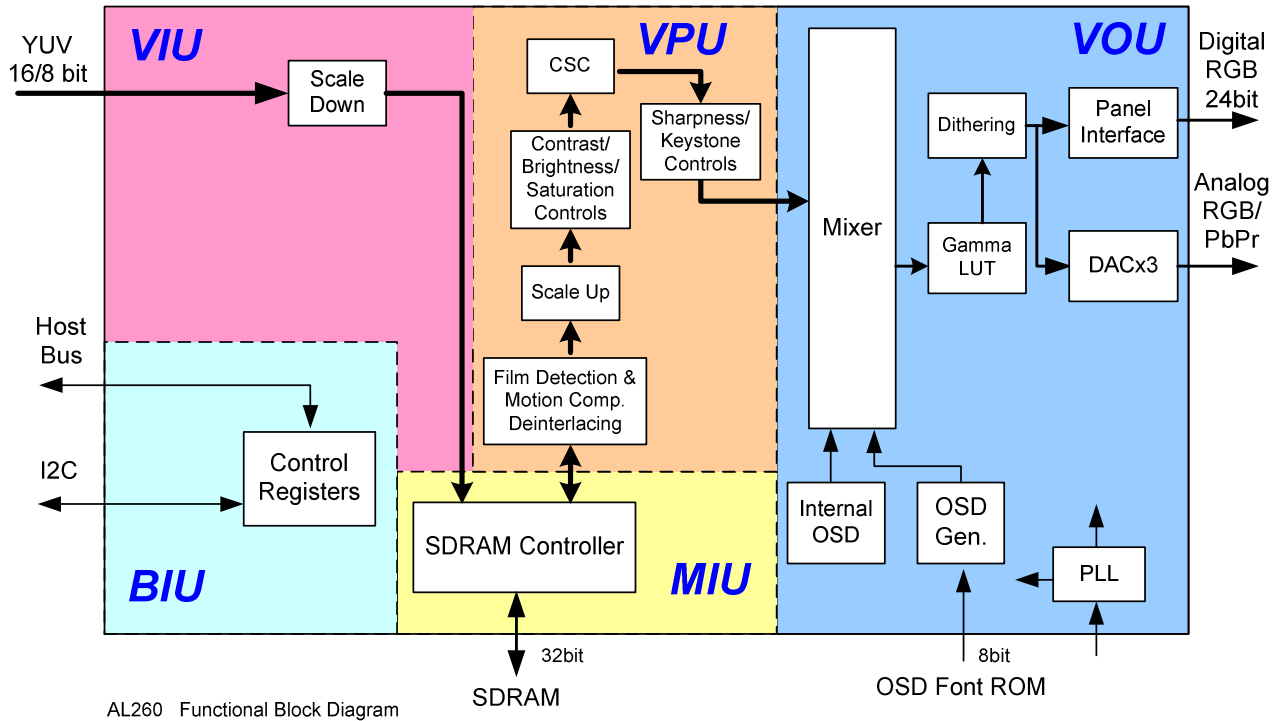

3. Features

3.1 General Features

- Support Digital YUV input and Non-interlaced RGB/YPbPr Analog and Digital outputs
- Film Detection with Inverse 3:2/2:2 Pull Down
- Advanced De-interlacing with Motion Compensation
- AverLogic's Proprietary Cubic Scaling Algorithm for Scaling Up and Down
- Built-in 2K Bytes OSD RAM and support External OSD Font ROM
- Available in 208-pin PQFP
- 2.5V Core and 3.3V I/O power supplies with 5V input tolerant

3.2 Feature Description:

- Input Interface
 - NTSC/PAL support
 - Video interface ITU-R 601/656(8/16bit), YUV422 support

- Output Interface
 - Output resolution up to 1280x1024 @60Hz
 - Analog non-interlaced RGB/YPbPr output supported

- SDRAM Interface
 - Support maximum 32bit bus width SDRAM interface, two SDRAMs configuration up to 125 MHz supported

- De-interlacing and Scan Rate Conversion
 - De-Interlacing for Interlaced Video Input
 - Motion Compensation De-interlacing with Spatial and Temporal Filtering support
 - Film Detection with Inverse 3:2 & 2:2 pull down
 - Frame Rate Conversion(FRC) from 50Hz up to 120Hz

- Scaling Engine and Video Processing
 - Independent Scale Up and Down in both Horizontal and Vertical direction with 4-line, high precision interpolation
 - Digital Brightness/Contrast/Saturation Control
 - Keystone Correction for Front-Projection Systems
 - Sharpness Control
 - Built-in LUT for Gamma Correction and Color Adjustment
 - Dithering Logic for Color Depth Enhancement

- I2C or Parallel Port Registers Access
 - Registers can be accessed by serial I2C port or 8 bit parallel port for high speed registers data update

- On Screen Display (OSD)
 - 2K Bytes Internal OSD RAM for fine bitmaps and text font

- Dual internal OSD windows support with Alpha Blending/Transparency effect
- Support up to 64K Bytes External ROM for Font or Bitmap data
- In ROM mode, Internal OSD RAM supports 1.5K Bytes for Context RAM, 0.5K Bytes for Pre-fetch RAM
- Pre-fetch RAM supports different speed types of Font ROMs (EE-PROM, PROM or Mask-ROM)

- Other Features
 - Primary input stream VBI pass through support
 - Frame capture Mirroring support in Horizontal or Vertical direction
 - NTSC/PAL Video Input Auto-Detection support
 - Power Saving support
 - Slave mode support

- Operating Power
 - 2.5V core and 3.3V I/O power supplies with 5V input tolerant

- Package
 - 208-pin PQFP

4 Applications

- LCD TV
- DTV & Front Projection/Rear Projection/Progressive Scan TVs
- TV to PC Monitor Format/Scan Rate Converter
- Video Enhancer/TV Tuner box

5 Application Example

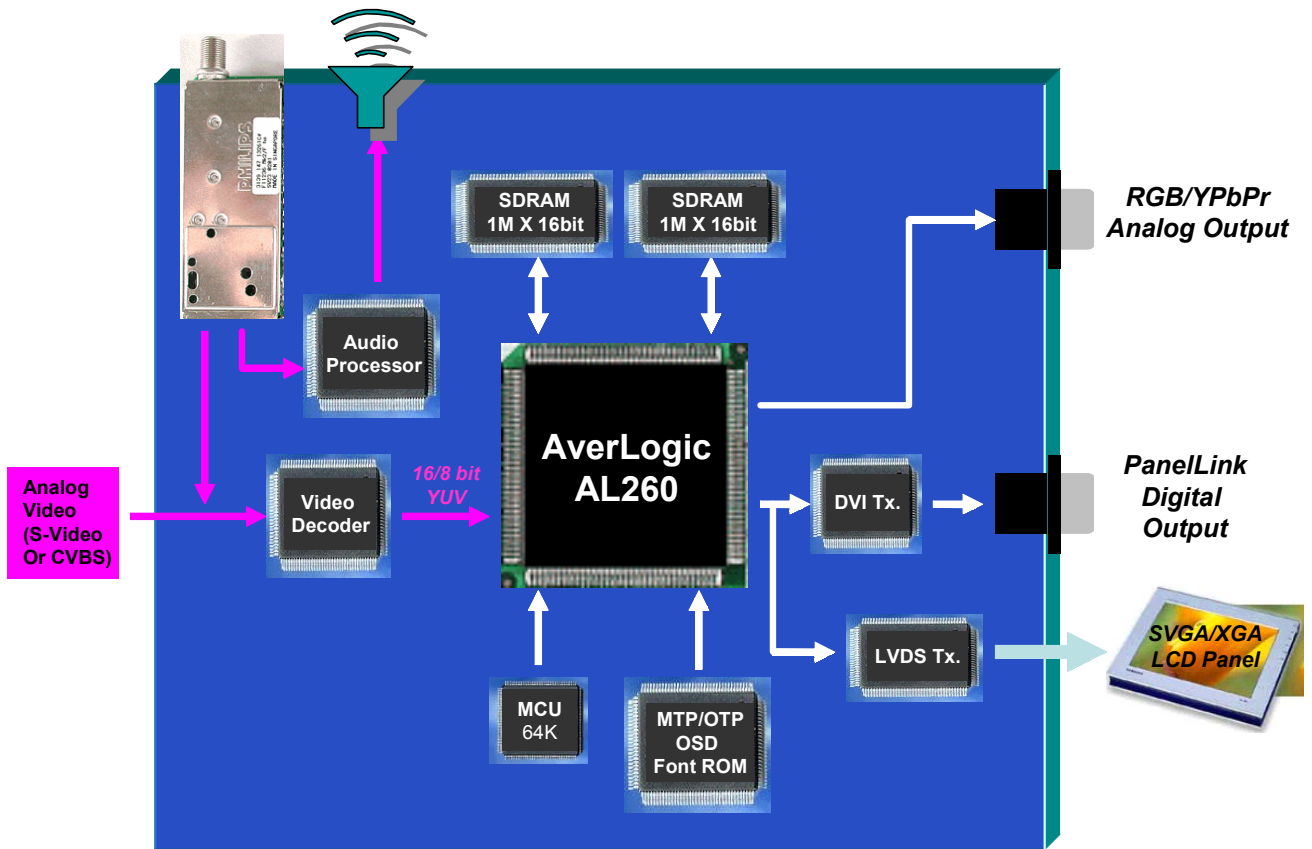

6 Pin-Out Diagram

PQFP-208 Package:

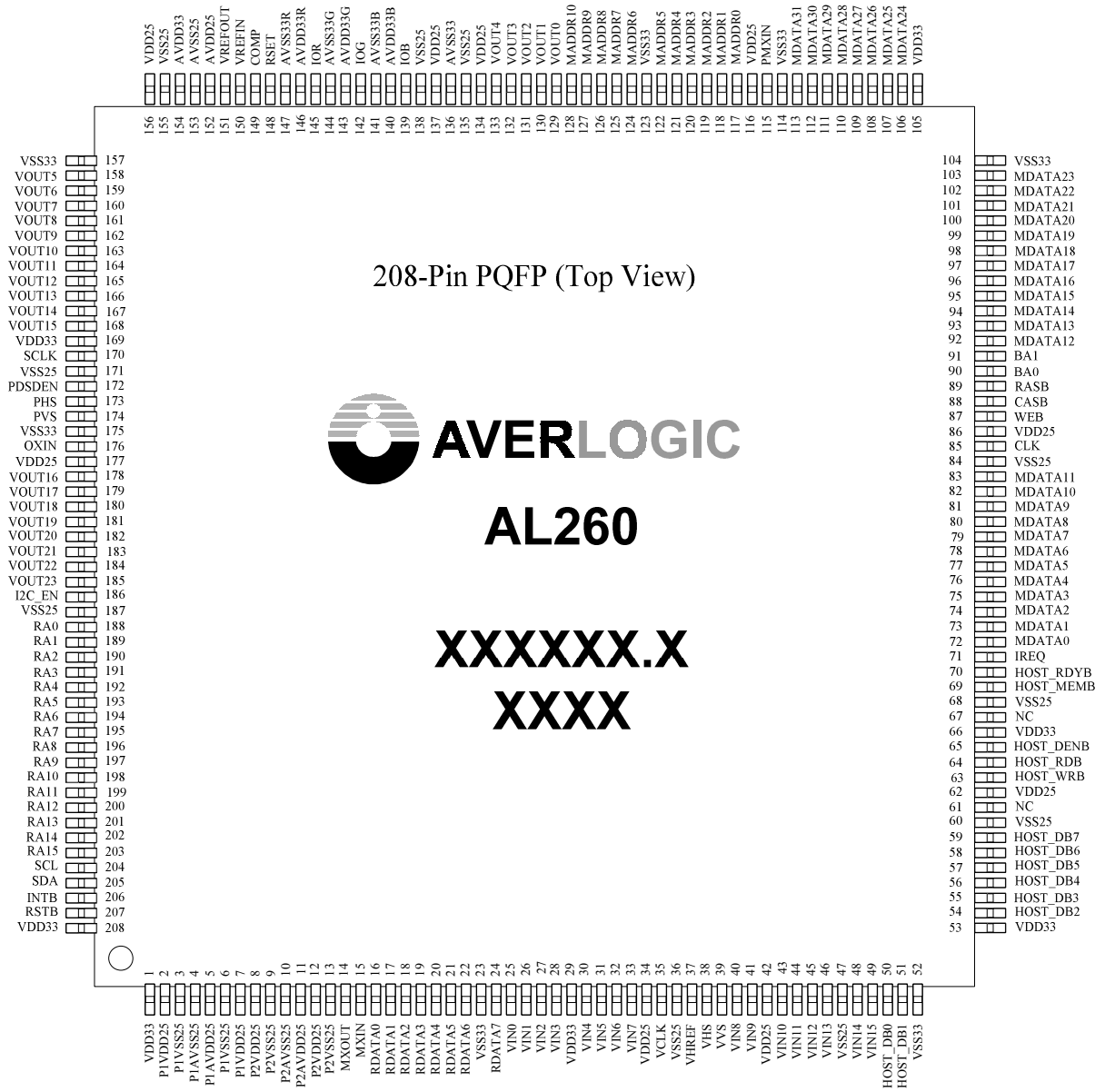

7 Pin Definition and Description

7.1 Input Format Table of AL260:

VIN No.	15~8	7~0
VIDEO	Y	CbCr YCbCr

The pin-out definitions are described as follows:

Pin Name	Pin Number	I/O type	Description
Input Interface			
VIN [15:14], [13:10], [9:8]	49-48, 46-43, 41-40	I	Video Input Bus Bit 15-8, lower 8 bits of ITU-R 601 16bit data bus
VIN [7:4], [3:0]	33-30, 28-25	I	Video Input Bus Bit 7-0, upper 8 bits of ITU-R 601 16bit data bus OR Video Input Bus Bit 7-0 of ITU-R 656 8bit
VCLK	35	I	Reference Clock of Video Port
VHREFF	37	I	HDE of Video Port
VHS	38	I	HSYNC of Video Port
VVS	39	I	VSYNC of Video Port
OSD ROM Interface			
RDATA [6:0], [7]	22-16, 24	I	ROM Data Bus Bit 7-0
RA [15:0]	203-188	O	ROM Address Bus Bit 15-0
DAC Output Interface			
AVDD33	154	AP	3.3v Analog Power for DAC
AVSS33	136	AG	Analog GND for DAC
AVDD25	152	AP	2.5V Analog Power for DAC
AVSS25	153	AG	Analog GND for DAC
AVDD33R	146	AP	3.3 V Analog Power for Channel R

Pin Name	Pin Number	I/O type	Description
AVSS33R	147	AG	Analog GND for Channel R
AVDD33G	143	AP	3.3 V Analog Power for Channel G
AVSS33G	144	AG	Analog GND for Channel G
AVDD33B	140	AP	3.3 V Analog Power for Channel B
AVSS33B	141	AG	Analog GND for Channel B
DVDD25	137	AP	2.5V Digital Power for DAC
DVSS25	138	AG	Digital GND for DAC
IOR	145	O	Channel R Current Output
IOG	142	O	Channel G Current Output
IOB	139	O	Channel B Current Output
RSET	148	I	Full-Scale Adjust Resister
COMP	149	I	Compensation Pin
VREFIN	150	I	Voltage Reference Input
VREFOUT	151	O	Voltage Reference Output
Digital Output Panel Interface			
VOUT [23:16], [15:5], [4:0]	185-178, 168-158, 133-129	O	Digital Video Output Bit 23-0
SCLK	170	O	Display Pixel Clock
PDSDEN	172	O	Display Data Enable
PHS	173	I	HSYNC Input for Slave Mode
PVS	174	I	VSYSNC Input for Slave Mode
OXIN	176	I	Reference Clock for Display Device
SDRAM Interface			
MDATA [31:24], [23-12], [11:0]	113-106, 103-92, 83-72	I/O	SDRAM Data Bus Bit 31-0
MADDR [10:6], [5:0]	128-124, 122-117	I/O	SDRAM Address Bit 10-0

Pin Name	Pin Number	I/O type	Description
PMXIN	115	I	SDRAM Read Data Input Sampling Clock
BA[1:0]	91-90	O	SDRAM Bank Address Bit 0-1
RASB	89	O	SDRAM Row Address Strobe
CASB	88	O	SDRAM Column Address Strobe
WEB	87	O	SDRAM Write Enable
CLK	85	O	SDRAM reference Clock
Host Interface			
HOST_DB [7:2], [1:0]	59-54, 51-50	I/O	Host Bus Bit 7-0
HOST_WRB	63	I	Reference Clock
HOST_RDB	64	I	Read/Write Strobe
HOST_DENB	65	I	Data Cycle
HOST_MEMB	69	I	Memory Cycle
HOST_RDYB	70	O	Read Data Ready Output
IREQ	71	O	Interrupt Output
SDA	205	I/O	Data Bit for Serial Bus
SCL	204	I	Clock Bit for Serial Bus
I2C_EN	186	I	I2C Enable
INTB	206	O	Interrupt for Serial Protocol
PLL Interface			
MXIN	15	I	Crystal Input (14.31818MHz)
MXOUT	14	O	Crystal Output
P1VDD25	2,7	DP	2.5V Pad Ring Power for PLL1
P1VSS25	3,6	DG	Pad Ring GND for PLL1
P1AVDD25	5	AP	Analog Power for PLL1
P1AVSS25	4	AG	Analog GND for PLL1
P2VDD25	8,12	DP	2.5V Pad Ring Power for PLL2
P2VSS25	9,13	DG	Pad Ring GND for PLL2
P2AVDD25	11	AP	Analog Power for PLL2
P2AVSS25	10	AG	Analog GND for PLL2
Others			

Pin Name	Pin Number	I/O type	Description
RSTB	207	I	Reset
NC	61, 67		No Connection
DIGITAL POWER / GROUND			
VDD25	34, 42, 62, 86, 116, 134, 156, 177	DP	Digital Power 2.5V
VSS25	36, 47, 60, 68, 84, 135, 155, 171, 187	DG	Digital Ground 2.5V
VDD33	1, 29, 53, 66, 105, 169, 208	DP	Digital Power 3.3V
VSS33	23, 52, 104, 114, 123, 157, 175	DG	Digital Ground 3.3V

Note: For I/O type, “I”, “O”, “AP”, “AG”, “DP”, and “DG” stand for “Input”, “Output”, “Analog Power”, “Analog Ground”, “Digital Power”, and “Digital Ground” respectively.

8 General Function Description

8.1 Function Blocks

AL260 provide a fully programmable structure allowing video stream process more flexible. The AL260 data process is executed by parsing in the modules such as capture, down scale, memory, up scale and mixer. In each module, data will be manipulated corresponding to the setting of registers. Due to the lack of the number of registers, some registers require banking to other page for access. There are 4 group registers, base control registers, capture control registers, memory control registers and display control registers. The value of base register 0eh determines which group of registers is taken effect. If register 0eh is programmed to value 00, the group of base control registers is chosen; and the register 0eh with value 01 is for capture register group, value 02 is for memory register group and value 03 is for display register group. The register 0eh must be set to corresponding value before that group of register can be accessed.

Register	Group ID	Group register Description		Symbol	Example
0Eh	<1:0>	00	Access only base control registers	BAS#	BAS#16
		01	Access capture and base control registers	CAP#	CAP#20
		10	Access memory and base control registers	MEM#	MEM#32
		11	Access display and base control registers	DIS#	DIS#61

8.2 VIU (Video Input Unit)

AL260 accepts 16/8bit YUV 4:2:2 (NTSC/PAL) video data stream with ITU-R-656/601 standards. Applying AverLogic Proprietary Scaling algorithm, the video stream can be scaled down to accommodate required output resolutions with high quality scaling effect. The high quality scaling engine also ensures full screen output display.

8.2.1 Input Data Format

The AL260 is an integrated video processor that automatically detects and converts multiple video formats. The Index and Base registers provide user an expansion of the

control registers, which implements easy control of the input and the desired output format. The Base registers control the input type and target format.

The AL260 accepts two data formats: 8-bit ITU-R BT.656 (CCIR656) and 16-bit CCIR601 422. The clock and sync signal pins separate for RGB or YUV while the YUV data share the same pins as RGB data. For detailed applications, please refer to AL260 Application Notes.

8.2.2 Video Capture and Down Scale Engine

The AL260 has a high-quality scaling engine performing proprietary scaling operations independently in both Horizontal and Vertical direction with 4-line, high precision interpolation.

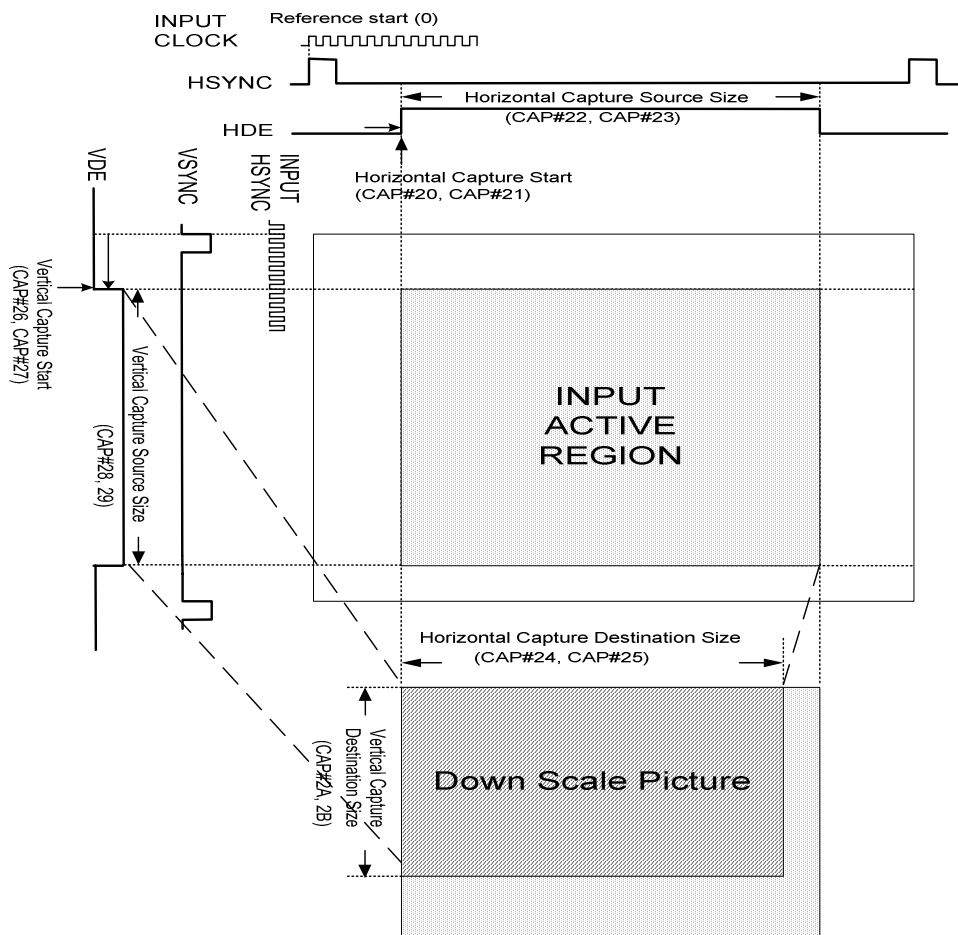

AL260 Input/Capture timing and Down Scale

8.2.3 Automatic Positioning Registers

The AL260 can detect and report input capture timing for Auto-adjustment function. It detects the starting and ending positions of active video in both direction (Horizontal and Vertical) and ensures the output fit properly into the display region. The data threshold value defines the sensibility of valid data. The capture data will be sampled and qualified base upon the value of data threshold, so that it can determine the starting point and ending point of an active line or an active frame.

8.2.4 PLL Programming for Memory and Display Clock

AL260 embedded 2 independent 200MHz PLL-Based Clock Generator. One is used to generate SDRAM clock, the other is for output clock. They are all reference input clock from XIN (generally 14.318MHZ).

There are 3 operation modes in defined in PLL register: Power Down Mode, Bypass Mode and Normal Mode. Power Down Mode forces FOUT to low and PLL in low power consumption state (<10uW). Bypass Mode provides FOUT with the same frequency as FIN. Normal Mode synthesizes FOUT by programming suitable divider values. It needs a Tready time (Pull_in Time + Locking Time) for PLL to re-lock the FIN clock when PLL wakes up from Power Mode to Normal Mode. In general, it should be reserved a Tread time for re-locking when PLL is changed to Normal Mode from Power Mode or Bypass Mode, or when any divider setting is changed.

8.3 MIU (Memory Interface Unit)

MIU supports SDRAM 32bit bus width interface. AL260 supports various SDRAM configurations, such as 512Kx16, 2ea. It uses sequential Burst mode to control SDRAM memory that operates at minimum 120MHz of clock frequency. For detailed operation of SDRAM, please reference memory specifications.

8.3.1 DRAM Bandwidth Consideration

The AL260 uses external DRAMS for the purpose of frame rate conversion between the

input video and the output video device. The frame rate conversion for video is done by double buffering.

8.3.2 DRAM Input/Output Windows

The proceeding diagrams will describe the DRAM input control.

The DRAM input data size depends on the horizontal capture destination size.

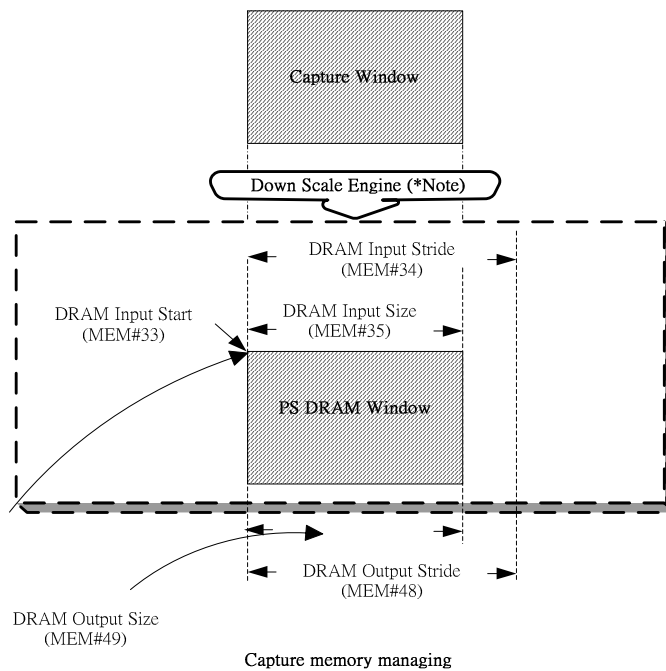

After the input data size has been defined, the memory address of input data can be determined by the register DRAM input stride. The DRAM input stride can be programmed to provide extra memory space for input data.

8.3 VPU (Video Processing Unit)

AL260 identifies video input sources including Progressive Film (24/25 frames/sec) and Interlaced Video (50/60 fields/sec) and selects appropriate de-interlacing algorithm for video enhancement. VPU supports Film Detection with Inverse 3:2 or 2:2 Pull Down and AverLogic Proprietary De-interlacing. When AL260 detects the video source as Film, then

progressive scan frames will be reassembled and output twice input rate such as 50/60 frame/sec. Otherwise, it will be taken as Interlaced Video Source, and processed by using De-interlacing to reduce video artifacts. The scaling engine offers Scale-Up effect by applying Cubic Scaling Algorithm. It supports independent Scale-Up in both Horizontal and Vertical direction with 4-line, high precision interpolation. AL260 also offers Digital Contrast, Brightness, and Saturation for Color adjustment. It can be adjusted in YUV data. The Sharpness Control provides good effect for image enhancement. It also provides Keystone function for Projector application.

8.4.1 Video De-Interlaced with Film Detection and Motion Adaptive

Video Processing unit equips a high quality de-interlacing algorithm to optimize the output progressive scan frame by recovering film sequence and compensating motion effect during the de-interlacing process. The motion estimation can evaluate both Y/C data or Y data by setting register. In Motion compensation process, the sensitivity of the data estimation can be adjusted by register for Lumina and Chroma threshold. In film video, such as DVD movie, some duplicate fields are inserted into the interlaced video stream. Original film sequence detection and recovery can produce a smooth progressive scan frame transition after de-interlaced.

8.4.2 Up Scale Engine

The Up Scale Engine can scale up Primary Stream to higher resolution in high quality for output display. The AL260 adapts FIR scaling engine that can do horizontal and vertical up scale independently. The primary stream picture can be either down scale to smaller size of picture or up scale to larger size of picture from original capture (input) picture for output, but it can not do both up and down scale process at the same time. Consider to capture full picture of input data if the output resolution of primary stream picture is going to be enlarged.

Following block diagram illustrates the define registers of source primary stream window and destination up scale window.

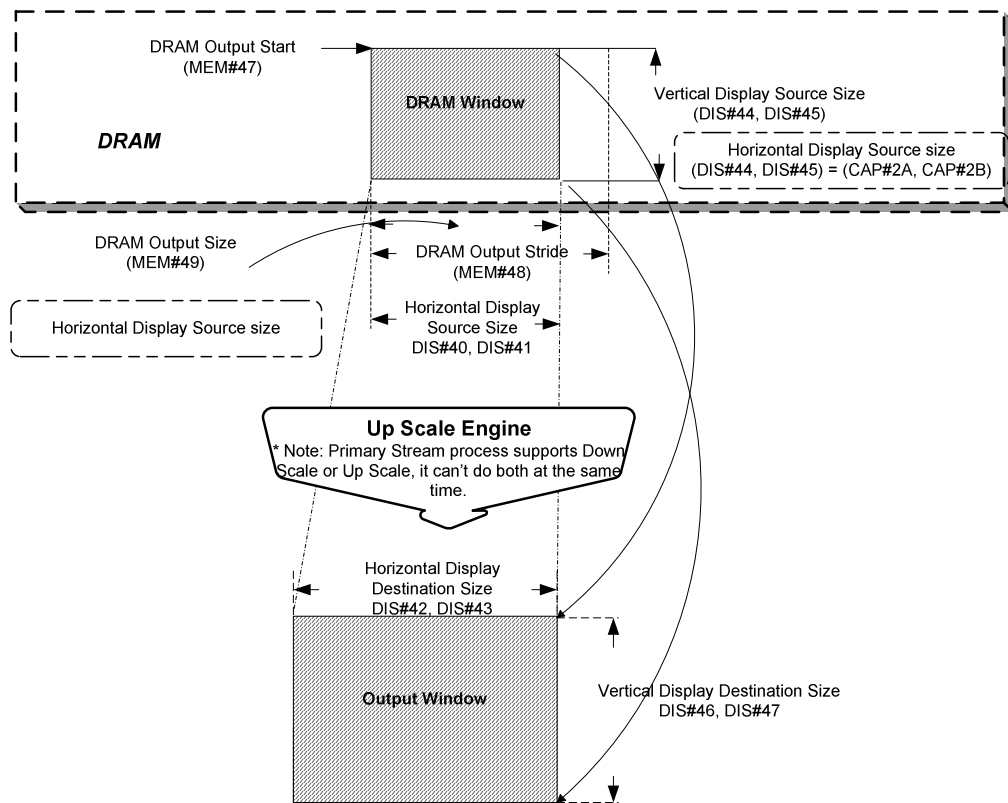

Up scale block diagram and defined registers

8.4.3 Keystone Up Scale Engine

The AL260 can scale up the image in dynamic ratio which is good for LCD projector image correction. The projected images from the LCD projector sometimes show as Figure due to the misalignment or cheap optics. The AL260 can up scale picture in dynamic ratios which are loaded from pre-stored at internal FIFO buffers. The keystone is designed to compensate the distortions, such as figures following.

8.4VOU (Video Output Unit)

Two independent On-Screen-Display (OSD) windows provide overlay for a control menu, text, or caption on the output display. The AL260's OSD is very flexible in the way that the font, size, and display location are all programmable. The internal 2K byte SRAM provides storage for the OSD information. The OSD can be operated with only this

internal SRAM or with an external ROM to store font tables or even larger bitmaps. Built-in 8bit Programmable Gamma Look-Up Table for each input color channel for Gamma Correction. It may be used for RGB Contrast, Brightness and Color Temperature adjustments. Dithering is performed to retain color resolution for LCD panels that support 18-bit color depths.

AL260 provides Digital video output interface that can be directly connected to 24bit TFT LCD Panel or DVI/LVDS Transmitters. It also provides Analog video output which can support up to SXGA resolution.

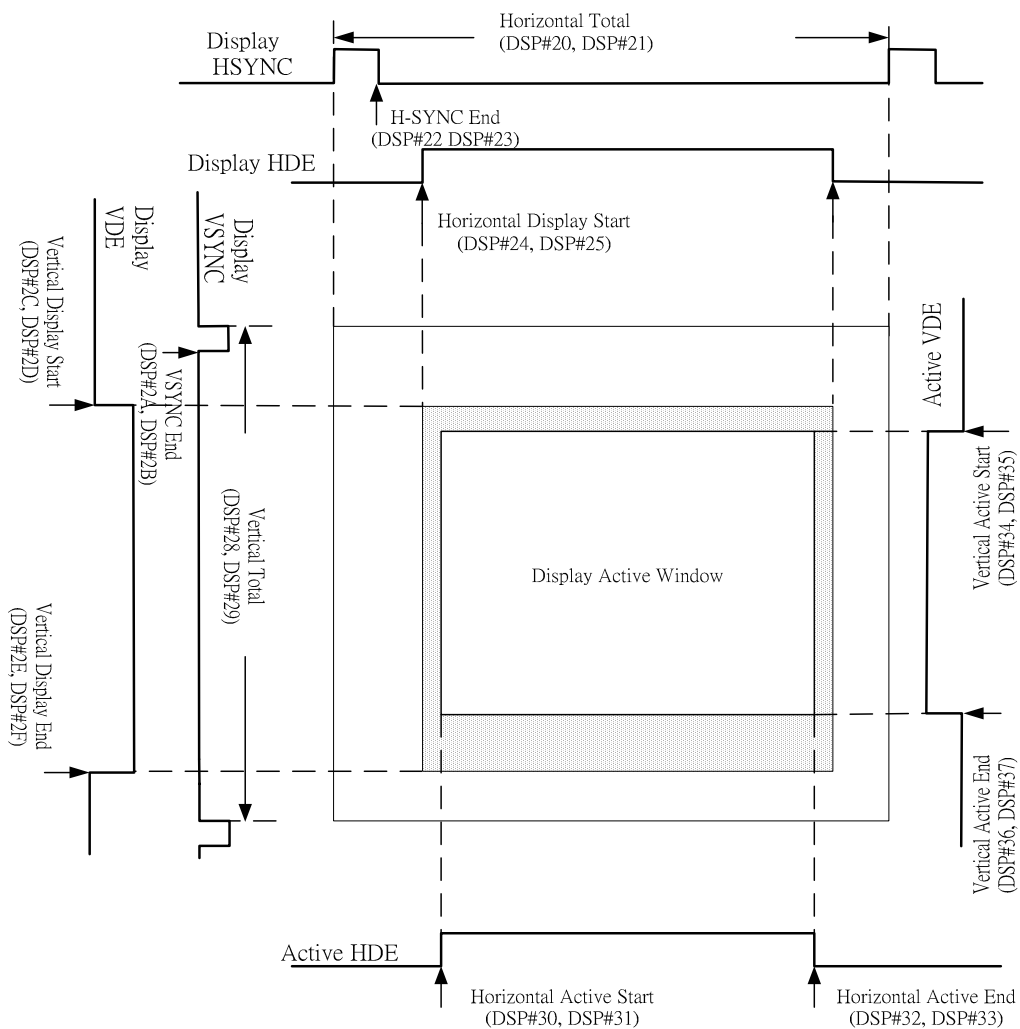

AL260 Output timing and display windows

8.5.1 OSD

Two independent On-Screen-Display (OSD) windows provide overlay for a control menu, text, or caption on the output display. The AL260's OSD is very flexible in the way that the font, size, and display location are all programmable. The internal 2K byte SRAM provides storage for the OSD information. The OSD can be operated with only this internal SRAM or with an external ROM to store font tables or even larger bitmaps.

Regarding the detailed usage, please refer to AL260's OSD Application Note.

8.5.2 LUT (Look up table for Gamma Correction and Color Enhancement)

Because of the different characteristics of TV's and PC monitors, direct color space conversion from TV to PC may not show the same color that the human eye sees from the original video on the TV. The contrast may not be sufficient, and the hue may not be accurate, so to resolve these issues the AL260 has a gamma correction internal LUT implemented.

The AL260 provides programmable registers for implementing the LUT. The directly converted colors are sent to the LUT that then sends out the mapped, corrected colors.

The user can program the LUT based on his/her own experiments on specific types of monitors. The typical input-output mapping curve is usually somewhat like the following:

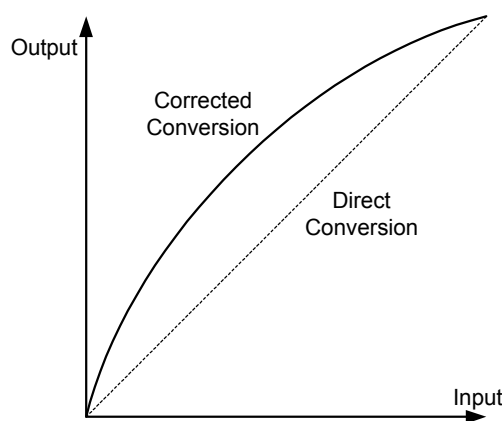

Figure 11 LUT Mapping

8.5.3 Dithering

The AverLogic offers dithering technique that simulates display of colors that are not in the current color space of a particular image. The Dithering logic provides additional color depth enhancement to retain color resolution for LCD panels that support 18-bit color depth.

8.5 BIU (Bus Interface Unit)

It supports I²C serial and proprietary parallel programming interfaces. I²C serial interface requires two wires to access while the proprietary parallel interface needs 11 wires. The communication speed of proprietary parallel interface is much faster than I²C serial interface.

Regarding to the detailed usage, please refer to AL260's General Application Note.

9 Register Definition

Registers are provided to setup AL260. These registers can be programmed via host interface. The host interface protocol is illustrated in “Host Interface” paragraph. The application notes will describe more detailed settings about these registers. Upon request, AverLogic will provide the sample code or tool of host interface control software.

9.1 Register Set

Register Name	Address	R/W	Default	Function
Base Control Group Registers				
COMPANYID	00h	R	46h	Company ID
INTRMASK	02h	R/W	00h	Interrupt Mask
INTRSTATUS	03h	R/W	00h	Interrupt Vector and Mode
CAPCTRL	06h	R/W	00h	Capture Data Control
DISCTRL1	07h	R/W	00h	Display Data Control 1
DISCTRL2	08h	R/W	00h	Display Data Control 2
POLARITYCTRL	09h	R/W	00h	Display Polarity Control
OTIMECTRL	0Ah	R/W	00h	Display Timing Control
GROUPACCESS	0Eh	R/W	00h	Group Access ID
INSRCFORMAT	11h	R/W	00h	Input Video Source Format
INPUTCTRL	12h	R/W	00h	Input Control
HREFDLY	13h	R/W	00h	Horizontal Reference Delay
CAPCTRL1	14h	R/W	00h	Capture control 1
CAPCTRL2	16h	R/W	00h	Capture control 2
MEMACCR	17h	R/W	00h	Memory Access Control
INVMSB	18h	R/W	00h	Inverted MSB of Capture Data Format
PLLSETR	1Bh	R/W	00h	PLL Setting for Memory and Display
MPLLNF	1Ch	R/W	00h	LSB of NF Value for Memory PLL
MPLLNRO	1Dh	R/W	00h	MSB of NF/NR/NO Value for Memory PLL
OPLLNF	1Eh	R/W	00h	LSB of NF Value for Display PLL
OPLLNRO	1Fh	R/W	00h	MSB of NF/NR/NO Value for Display PLL
Capture Control Group Registers (Accessible when BAS#0E = 01h)				
Capture Timing				
CAPHSTART	21h & 20h	R/W	00h	Horizontal Capture Start

Register Name	Address	R/W	Default	Function
CAPHSRCSIZE	23h & 22h	R/W	00h	Horizontal Capture Source Size
CAPHDESTSIZE	25h & 24h	R/W	00h	Horizontal Capture Destination Size
CAVSTART	27h & 26h	R/W	00h	Vertical Capture Start
CAPVSRCSIZE	29h & 28h	R/W	00h	Vertical Capture Source Size
CAPVDESTSIZE	2Bh & 2Ah	R/W	00h	Vertical Capture Destination Size
INTERLACECTRL	2Eh	R/W	00h	Interlace Control
HDNRATIO	31h & 30h	R/W	00h	Horizontal Scale Down Ratio
VDNRATIO	33h & 32h	R/W	00h	Vertical Scale Down Ratio
VBI Input Timing				
VBIVSTART	34h	R/W	00h	VBI Vertical Capture Start
VBIVEND	35h	R/W	00h	VBI Vertical Capture End
VBIHSTART	36h	R/W	00h	VBI Horizontal Capture Start
VBIHSIZE	37h	R/W	00h	VBI Horizontal Capture Size
ITU-656 Detection				
656HSTART	38h	R/W	20h	ITU656 data Horizontal sync start
656HEND	39h	R/W	A0h	ITU656 data Horizontal sync end
656VSTART	3Ah	R/W	02h	ITU656 data Vertical sync start
656VEND	3Bh	R/W	04h	ITU656 data Vertical sync end
Position Detection				
POSDATATH	50h	R/W	00h	Data Threshold for Position Detection
POSHDESTART	53h & 52h	R		Horizontal Capture Active Start
POSHDEEND	55h & 54h	R		Horizontal Capture Active End
POSVDESTART	57h & 56h	R		Vertical Capture Active Start
POSVDEEND	59h & 58h	R		Vertical Capture Active End
Mode Detection				
CAPHTOTALCNT	63h & 62h	R		Horizontal Capture Total Counter
CAPVTOTALCNT	65h & 64h	R		Vertical Capture Total Counter
DBUFFLAGNUML	70h	R/W	00h	Double Buffer Flag Number LSB
DBUFFLAGNUMH	72h	R/W	00h	Double Buffer Flag Number MSB
TUNEINCLK	73h	R/W	00h	Tune Input Clock Timing
Memory Control Group Registers(Accessible when reg.0Eh = 02h)				
DRAM Control				

Register Name	Address	R/W	Default	Function
DRAMACCESSCTRL	20h	R/W	00h	DRAM Access control
DRAMWRITE	21h	R/W	00h	DRAM Write
OUTFIFOCTRL	22h	R/W	00h	Output FIFO Control
INFIFOCTRL	23h	R/W	00h	Input FIFO Control
DRAMMINREFRESH	28h	R/W	00h	DRAM Minimum Refresh
DRAMCTRL	2Ah & 29h	R/W	00h	DRAM Control Register
DRAMRADDR	2Dh ~ 2Bh	R/W	00h	DRAM Read Address
XYMIRRORIN	30h	R/W	00h	XY Mirror Input
XYMIRROROUT	31h	R/W	00h	XY Mirror Output
SKIPMODE	32h	R/W	10h	Skip Mode
DRAM Input Window Control				
DRAMSTART	33h	R/W	10h	DRAM Input Start
DRAMSTRIDE	34h	R/W	00h	DRAM Input Stride
DRAMISIZE	35h	R/W	00h	DRAM Input Size
DRAM Window Copy Control				
WCSRCSTART	3Bh ~ 39h	R/W	00h	Window Copy Source Start
GSDRAMINPUTSTRIDE	3Ch	R/W	00h	Window Copy Source Stride
GSDRAMINPUTSIZE	3Dh	R/W	00h	Window Copy HSize
WCSTRIDE	3Eh	R/W	00h	Direct Write Stride
WCDESTSTART	41h ~ 3Fh	R/W	00h	Window Copy Destination Start
DASTART	44h ~ 42h	R/W	00h	Direct Read/Write Address
WCSIZE	45h	R/W	00h	Window Copy Size
WCLINETOTAL	46h	R/W	00h	Window Copy Line Total
DRAM Output Window Control				
DRAMSTART	47h	R/W	00h	DRAM Output Start
DRAMSTRIDE	48h	R/W	00h	DRAM Output Stride
DRAMSIZ	49h	R/W	00h	DRAM Output Size
VBISTART	4Fh ~ 4Dh	R/W	00h	VBI Starting Address
FRONTMD	50h	R/W	00h	Front Motion Detect Control
TUNEMCLK	51h	R/W	00h	Tune Memory Write Clock Timing
TUNEPMCLK	52h	R/W	00h	Tune Memory Read Clock Timing
DRAM Data Port				

Register Name	Address	R/W	Default	Function
READSTATUS	60h	R		Read Status
BYTE0	61h	R/W	00h	Byte 0
BYTE1	62h	R/W	00h	Byte 1
BYTE2	63h	R/W	00h	Byte 2
BYTE3	64h	R/W	00h	Byte 3
BYTE4	65h	R/W	00h	Byte 4
BYTE5	66h	R/W	00h	Byte 5
Display Control Group Registers (Accessible when reg.0Eh = 03h)				
Display Timing				
DISHTOTAL	21h ~ 20h	R/W	00h	Display Horizontal Total
DISHSEND	23h & 22h	R/W	00h	Display Horizontal Sync
DISHDESTART	25h & 24h	R/W	00h	Horizontal Display Start
DISHDEEND	27h & 26h	R/W	00h	Horizontal Display End
DISVTOTAL	29h & 28h	R/W	00h	Display Vertical Total
DISVSEND	2Bh & 2Ah	R/W	00h	Display Vertical Sync
DISVDESTART	2Dh & 2Ch	R/W	00h	Vertical Display Start
DISVDEEND	2Fh & 2Eh	R/W	00h	Vertical Display End
Window Output Timing				
DISHDESTART	31h & 30h	R/W	00h	Horizontal Display Start
DISHDEEND	33h & 32h	R/W	00h	Horizontal Display End
DISVDESTART	35h & 34h	R/W	00h	Vertical Display Start
DISVDEEND	37h & 36h	R/W	00h	Vertical Display End
Zoom In Control Registers				
DISHSRCsize	41h & 40h	R/W	00h	Horizontal Display Source Size
DISHDESTsize	43h & 42h	R/W	00h	Horizontal Display Destination Size
DISVSRCSIZE	45h & 44h	R/W	00h	Vertical Display Source Size
DISVDESTSIZE	47h & 46h	R/W	00h	Vertical Display Destination Size
ZOOMFCTRL	48h	R/W	00h	Zoom In Filter Control
HUPRATIO	4Bh & 4Ah	R/W	00h	Horizontal Scale Up Ratio
DELTAHUPRATIO	4Bh & 4Ah	R/W	00h	Delta Horizontal Scale Up Ratio
VUPRATIO	4Dh & 4Ch	R/W	00h	Vertical Scale Up Ratio
HPHASE	4Fh & 4Eh	R/W	00h	Horizontal Scale Up Initial Phase

Register Name	Address	R/W	Default	Function
VPHASE	51h & 50h	R/W	00h	Vertical Scale Up Initial Phase
OUTPUTMODE	54h	R/W	00h	Output Mode
LUTINDEX	55h	R/W	00h	LUT Write Index
LUTRED	5Ch	R/W	00h	LUT Red Color LSB
LUTGREEN	5Dh	R/W	00h	LUT Green Color LSB
LUTBLUE	5Eh	R/W	00h	LUT Blue Color LSB
LUTCOLOR	5Fh	R/W	00h	LUT Color MSB and Read/Write Trigger
PATTERNGEN	56h	R/W	00h	Pattern Generator and GPO
OSD Color Registers				
OSDRAMWADDR	59h & 58h	R/W	00h	OSD Write Address
OSDRAMWDATA	5Ah	W	00h	OSD Write Data Port
COLOR0RED	60h	R/W	00h	Color 0 Red
COLOR0GREEN	61h	R/W	00h	Color 0 Green
COLOR0BLUE	62h	R/W	00h	Color 0 Blue
COLOR1RED	63h	R/W	00h	Color 1 Red
COLOR1GREEN	64h	R/W	00h	Color 1 Green
COLOR1BLUE	65h	R/W	00h	Color 1 Blue
COLOR2RED	66h	R/W	00h	Color 2 Red
COLOR2GREEN	67h	R/W	00h	Color 2 Green
COLOR2BLUE	68h	R/W	00h	Color 2 Blue
COLOR3RED	69h	R/W	00h	Color 3 Red
COLOR3GREEN	6Ah	R/W	00h	Color 3 Green
COLOR3BLUE	6Bh	R/W	00h	Color 3 Blue
COLOR4RED	6Ch	R/W	00h	Color 4 Red
COLOR4GREEN	6Dh	R/W	00h	Color 4 Green
COLOR4BLUE	6Eh	R/W	00h	Color 4 Blue
COLOR5RED	6Fh	R/W	00h	Color 5 Red
COLOR5GREEN	70h	R/W	00h	Color 5 Green
COLOR5BLUE	71h	R/W	00h	Color 5 Blue
COLOR6RED	72h	R/W	00h	Color 6 Red
COLOR6GREEN	73h	R/W	00h	Color 6 Green
COLOR6BLUE	74h	R/W	00h	Color 6 Blue

Register Name	Address	R/W	Default	Function
COLOR7RED	75h	R/W	00h	Color 7 Red
COLOR7GREEN	76h	R/W	00h	Color 7 Green
COLOR7BLUE	77h	R/W	00h	Color 7 Blue
OSD Control Registers				
OSDCOLORSEL	78h	R/W	00h	OSD Color Select
BLINKTIME	79h	R/W	00h	OSD Blink Timer
OSDMODE	80h	R/W	00h	OSD Modes
FOREOP	81h	R/W	00h	Logic Operation 1
FOREOP	83h	R/W	00h	Logic Operation 2
FADEALPHA	82h	R/W	00h	Fading Alpha Value
OSD1 Registers				
OSDCONTROL1	84h	R/W	00h	OSD1 Control
ROMSTARTADDR1	85h	R/W	00h	OSD1 ROM Start Address
FONTADDRUNIT1	86h	R/W	00h	OSD1 Font Address Unit
OSDHSTART1	90h	R/W	00h	OSD1 Horizontal Start
OSDVSTART1	91h	R/W	00h	OSD1 Vertical Start
RAMADDRST1	92h	R/W	00h	OSD1 RAM Start Address
RAMSTRIDE1	8Bh & 93h	R/W	00h	OSD1 RAM Horizontal Stride
BMAPHSIZE1	95h & 94h	R/W	00h	OSD1 Bitmap Horizontal Size
BMAPHTOTAL1	97h & 96h	R/W	00h	OSD1 Bitmap Horizontal Total Pixels
BMAPVSIZE1	99h & 98h	R/W	00h	OSD1 Bitmap Vertical Size
BMAPVTOTAL1	9Bh & 9Ah	R/W	00h	OSD1 Bitmap Vertical total Lines
ICONHTOTAL1	9Ch	R/W	00h	OSD1 Icon Horizontal Total
ICONVTOTAL1	9Dh	R/W	00h	OSD1 Icon Vertical Total
FONTLINESIZE1	AEh	R/W	00h	OSD1 Font Line Size
OSD2 Registers				
OSDCONTROL2	88h	R/W	00h	OSD2 Control
ROMSTARTADDR2	89h	R/W	00h	OSD2 ROM Start Address
FONTADDRUNIT2	8Ah	R/W	00h	OSD2 Font Address Unit
OSDHSTART2	A0h	R/W	00h	OSD2 Horizontal Start
OSDVSTART1	A1h	R/W	00h	OSD2 Vertical Start
RAMADDRST2	A2h	R/W	00h	OSD2 RAM Start Address

Register Name	Address	R/W	Default	Function
RAMSTRIDE2	8Ch & A3h	R/W	00h	OSD2 RAM Horizontal Stride
BMAPHSIZE2	A5h & A4h	R/W	00h	OSD2 Bitmap Horizontal Size
BMAPHTOTAL2	A7h & A6h	R/W	00h	OSD2 Bitmap Horizontal Total Pixels
BMAPVSIZE2	A9h & A8h	R/W	00h	OSD2 Bitmap Vertical Size
BMAPVTOTAL2L	ABh & AAh	R/W	00h	OSD2 Bitmap Vertical Total Lines
ICONHTOTAL2	ACh	R/W	00h	OSD2 Icon Horizontal Total
ICONVTOTAL2	ADh	R/W	00h	OSD2 Icon Vertical Total
FONTLINESIZE2	AFh	R/W	00h	OSD2 Font Line Size
Desktop Color Registers				
DESKR	B3h	R/W	00h	Desktop Color Component Red
DESKG	B4h	R/W	00h	Desktop Color Component Green
DESKB	B5h	R/W	00h	Desktop Color Component Blue
Film Detection/ Motion Compensation Registers				
MOTIONCNTTH	C5h & C4h	R/W	00h	Motion Counter Threshold
LUMATH	C6h	R/W	00h	Lumina(Y) Threshold
CHROMATH	C7h	R/W	00h	Chroma(C) Threshold
MCCTRL	C8h	R/W	00h	De-interlacing Control Register
FILMCTRL	C9h	R/W	00h	Film Detection Control Register
PHASECTRL	CAh	R/W	00h	Phase Detection Control Register
MVCNT	CFh & CEh	R	00h	Motion Pixel Numbers
Keystone/Sharpness Registers				
SHPKEYCTRL	CBh	R/W	00h	Sharpness/Keystone Control Register
KEYADDR	C1h & C0h	R/W	00h	Keystone Parameters Address
Tri-Level Sync Registers				
TRISYNCA	D0h	W	00h	Tri-Level Sync Parameter Period a
TRISYNCB	D1h	W	00h	Tri-Level Sync Parameter Period b
TRISYNCD1	D2h	W	00h	Tri-Level Sync Parameter Delta 1
TRISYNCD2	D3h	W	00h	Tri-Level Sync Parameter Delta 2
TRISYNCLANK	D4h	W	00h	Tri-Level Sync Parameter Period Blank
TRISYNCLEVEL	D7h	W	00h	Tri-Level Sync Level
Display Parameter Registers				
DISTUNEHS	C2h	R/W		Tune Display Horizontal Sync Phase

Register Name	Address	R/W	Default	Function
DISTUNESCLK	CCh	R/W		Tune Display Pixel Clock Phase
PHASECTRL	CAh	R/W		Phase Detection Control Register
DISHTOTAL	D8h & D7h	R		Display Horizontal Total Counter
DISVTOTAL	DAh & D9h	R		Display Vertical Total Counter
PHASECNT	DCh & DBh	R		Phase Counter
DISADJEN	F0h	R/W	00h	Enable Brightness/Contrast/Saturation
BRIGHTNESS	F1h	R/W	80h	Brightness Level
CONTRAST	F2h	R/W	40h	Contrast Level
SATURATION	F3h	R/W	40h	Saturation Level

9.2 Register Description

➤ Base Control Group Registers

INDEX	Register Description		
(HEX)	Register Name	BITS	Function Description
00	Company ID (R) [COMPANYID]		
	CompanyID	<7:0>	Company ID (46h)
02	Interrupt Mask (R/W) [INTRMASK]		
	DVsyncIntMask	<0>	Display VSYNC interrupt mask 0 Mask interrupt issued by VSYNC of display 1 Interrupt issued when display VSYNC is activated
	CAPVsyncIntMask	<1>	Capture VSYNC interrupt mask 0 Mask interrupt issued by VSYNC 1 Interrupt issued when VSYNC is activated
	Reserved	<2>	Reserved
	VBIMask	<3>	Display vertical blank interrupt mask 0 Mask interrupt issued by display vertical blank 1 Interrupt issued by display vertical blank
	FilmDetMask	<4>	H/W Film detected finished interrupt mask 0 Mask interrupt issued by film detection 1 Interrupt issued when HW film detected
	FullDetMask	<5>	FIFO full for directly memory write Interrupt Mask 0 Mask interrupt issued by FIFO full for directly write to SDRAM 1 Interrupt issued by FIFO full for directly write to SDRAM
	WCopyEndMask	<6>	Window copy finished interrupt mask 0 Mask interrupt issued by window copy 1 Interrupt issued by window copy
	FIFOFullMask	<7>	Arbiter FIFO full interrupt mask 0 Mask interrupt issued by FIFO index of arbiter 1 Interrupt issued when FIFO is full

03 Interrupt Vector and Mode (R)(W) [INTRSTATUS]

DVsyncInt (R)	<0>	Display VSYNC interrupt
CAPVsyncInt (R)	<1>	Capture VSYNC interrupt
Reserved	<2>	Reserved
VBIInt (R)	<3>	Display vertical blank interrupt
FilmDet (R)	<4>	H/W Film detected finished interrupt
FullDet (R)	<5>	FIFO full for directly memory write interrupt
WCopyEnd (R)	<6>	Window copy finished interrupt
FIFOFull (R)	<7>	Arbiter FIFO full interrupt
IntMode(W)	<0>	0 Triqaer mode
		1 Level mode
	<1>	0 High active
		1 Low active
	<7:2>	Reserved

04~05: Reserved

06 Capture Data Control (R/W) [CAPCTRL]

CapVScaleDn	<0>	Capture vertical scale down enable
		0 Disable
		1 Enable
Reserved	<4:1>	Tie to "0000"
SoGo	<5>	Display timing strobe by capture VSYNC
Reserved	<6>	Tie to 1
GO	<7>	Capture timing enable
		0 Disable
		1 Enable

07 Display Data Control 1 (R/W) [DISCTRL1]

Reserved	<2:0>	Tie to "011"
CscEn	<3>	Capture data color space conversion
		0 Disable color space converter
		1 Enable color space converter

Reserved <7:4> Reserved

08 Display Data Control 2 (R/W) [DISCTRL2]

UVFlip2Path <0> U/V flip in display data path
 0 Disable
 1 Enable

UVFlip2Mem <1> U/V flipped in capture data path
 0 Disable
 1 Enable

Reserved <2> Tie to "0"

YPbPrEn <3> Color space conversion, refer to BAS#07<3>
 0 YCbCr to RGB conversion
 1 YPbPr to RGB conversion

Reserved <7:4> Reserved

09 Display Polarity Control (R/W) [POLARITYCTRL]

OCkSel <0> Output clock source selection as display clock, refer to BAS#09<7>
 0 Select OXIN1 as display clock
 1 Select OXIN2 as display clock

ControlEn <1> Panel output data signals (clock, data, HSYNC, VSYNC and PDE) control enable
 0 Disable output data signals to panel, all output data signals tie to low
 1 Enable panel output data signals

HSyncPol <2> Output horizontal sync polarity
 0 Positive
 1 Negative

BlankPol <3> Output horizontal blank polarity
 0 Positive
 1 Negative

VSyncPol <4> Output vertical sync polarity
 0 Positive
 1 Negative

InvertOdd	<5>	Invert odd field signal
	0	Positive
	1	Negative
CSyncOut	<6>	Composite sync out
	0	Separate
	1	Composite
OPLLsel	<7>	Display reference clock source, refer to BAS#09<0>
	0	From external pin (OXIN1/OXIN2)
	1	From PLL

0A Display Timing Control (R/W) [OTIMECTRL]

WinDisable	<0>	Display window diable
	0	Enable
	1	Disable
Reserved	<1>	Reserved
SlaveMode	<2>	Slave mode enable, refer to BAS#0A<3>
	0	Output timing driven by internal registers
	1	Output timing driven by external device(capture or external display device)
SlaveType	<3>	Slave mode type, refer to BAS#0A<2>
	0	Output timing is driven by capture timing
	1	Output timing is driven by external display device
CSYNCType	<5:4>	Compsit SYNC type
	00	XOR
	01	AND
	10	NXOR
	11	NAND
YPbPrAnalogOut	<6>	YPbPr analog output
	0	RGB output
	1	YpbPr output
YPbPrDigitalOut	<7>	YPbPr digital output
	0	RGB output
	1	YpbPr output

0E Group Access ID (R/W) [GROUPACCESS]

GroupAccessID	<1:0>	Group register access control
	00	Access only Base control registers
	01	Access Capture and Base control registers
	10	Access Memory and Base control registers
	11	Access Display and Base control registers
Reserved	<7:2>	Reserved

11 Input Video Source Format (R/W) [INSRCFORMAT]

CapInFormat	<1:0>	Capture data input format
	00	Reserved
	01	16-bit
	10	8-bit
	11	Reserved
Reserved	<5:2>	Reserved
Reserved	<6>	Tie to 0
Reserved	<7>	Reserved

12 Input Control (R/W) [INPUTCTRL]

Reserved	<2:0>	Tie to "000"
HsPol	<3>	Enable HS polarity detection
	0	Disable, when turn on auto position function
	1	Enable
VsPol	<4>	Enable VS polarity detection
	0	Disable, when turn on auto position function
	1	Enable
Reserved	<7:5>	Reserved

13 Horizontal Reference Delay (R/W) [HREFDLY]

CapHRefDly	<3:0>	Capture HRef delay
Reserved	<7:4>	Reserved

14 Capture control 1 (R/W) [CAPCTRL1]

CapHScaleDn	<0>	Enable horizontal capture scale down
-------------	-----	--------------------------------------

Reserved	<1>	Reserved
Cap656SyncSel	<2>	Capture SYNC source when ITU656 input
		0 From external SYNC input pin
		1 From decoded ITU656 data
CapSoftRef	<3>	Capture HREF source
		0 From external HREF input pin
		1 Software programmable
Reserved	<7:4>	Reserved

16 Capture control 2 (R/W) [CAPCTRL2]

Reserved	<1:0>	Tie to "00"
InvOddField	<2>	Invert internal detected capture odd field signal
Reserved	<3>	Reserved
Cap444En	<4>	Input data format
		0 YPbPr input format
		1 YCbCr input format
Cap656En	<5>	Enable input source is ITU656 format
DEdgeEn	<6>	Double edge sampling for ITU656 input
Reserved	<7>	Reserved

17 Memory Access Control Register(R/W) [MEMACCR]

MemWEn	<0>	Directly write enable
MemREn	<1>	Directly read enable
HostMode	<2>	Host data mode
		0 2x16-bit per each host cycle
		1 1x24-bit per each host cycle
Reserved	<3>	Tie to "1"
DMAEn	<4>	Enable data output of directly memory
Reserved	<5>	Reserved
WCopyEn	<6>	Window copy enable
		0 Disable window copy
		1 Enable window copy
MclkSel	<7>	Memory clock select
		0 Memory clock from external PIN (XIN)

1 Memory clock from internal PLL

18 Inverted MSB of Capture Data Format (R/W) [INVMSB]

InvBit7	<0>	Inverted bit 7 of input data
InvBit15	<1>	Inverted bit 15 of input data
InvBit23	<2>	Inverted bit 23 of input data
Reserved	<7:3>	Reserved

Note: Please refer to General Application Note

PLL Registers

1B PLL Setting Register for Memory and Display(R/W) [PLLSETR]

OPLLPd	<0>	Power Down for Display PLL
		0 PLL normal Operation
		1 PLL Power Down
OPLLVon	<1>	Reset for Display PLL
		0 PLL normal Operation
		1 Reset the PLL NF & NR Divider
OPLLBp	<2>	Bypass Mode for Display PLL
		0 PLL normal Operation
		1 Bypass the PLL & FOUT=FIN
OPLLOe	<3>	Output Control for Display PLL
		0 FOUT= Fck/NO
		1 FOUT=0
MPLLPd	<4>	Power Down for Memory PLL
		0 PLL normal Operation
		1 PLL Power Down
MPLLVon	<5>	Reset for Memory PLL
		0 PLL normal Operation
		1 Reset the PLL NF & NR Divider
MPLLBp	<6>	Bypass Mode for Memory PLL
		0 PLL normal Operation
		1 Bypass the PLL & FOUT=FIN
MPLLOe	<7>	Output control for memory PLL
		0 FOUT= Fck/NO

1 FOUT=0

Note: $FOUT = FIN * NF / (NR * NO) = FVCO / NO$, here FVCO is between 80MHz and 190Mhz

Here, FIN is input clock (example:14.31818MHz XTAL)

NF/NR, and NO are refer to BAS#1C~1F definition

1C **LSB of NF Value for Memory PLL(R/W) [MPLLNF]**

MPLLNF <7:0> MPLLNF<7:0> Value for memory PLL

Note: NF is MPLLNF+2

1D **MSB of NF/NR/NO Value for Memory PLL(R/W) [MPLLNRO]**

MPLLNR <4:0> MPLLNR<4:0> value for memory PLL

MPLLNO <6:5> MPLLNO<1:0> value for memory PLL

MPLLNF <7> MPLLNF<8> Value for memory PLL

Note: NR is MPLLNR+2, NO is MPLLNO+1

1E **LSB of NF Value for Display PLL(R/W) [OPLLNF]**

OPLLNF <7:0> OPLLNF<7:0> Value for display PLL

Note: NF is OPLLNF+2

1F **MSB of NF/NR/NO Value for Display PLL(R/W) [OPLLNRO]**

OPLLNR <4:0> OPLLNR<4:0> value for display PLL

OPLLNO <6:5> OPLLNO<1:0> value for display PLL

OPLLNF <7> OPLLNF<8> Value for display PLL

Note: NR is OPLLNR+2, NO is OPLLNO+1

➤ **Capture Control Group Registers (Accessible when BAS#0E = 01h)**

I. Capture Timing

INDEX	Register Description		
(HEX)	Register Name	BITS	Function Description
20	<u>Horizontal Capture Start LSB (R/W) [CAPHSTART]</u>		
	CapHStartL	<7:0>	Bits<7:0> of horizontal capture start position (Unit: 1 pixel)
21	<u>Horizontal Capture Start MSB (R/W) [CAPHSTART]</u>		
	CapHStartH	<3:0>	Bits<11:8> of horizontal capture start position
	Reserved	<7:4>	Reserved
22	<u>Horizontal Capture Source Size LSB (R/W) [CAPHSRCSIZE]</u>		
	CapHSrcSizeL	<7:0>	Bits<7:0> of horizontal capture source size (Unit: 1 pixel)
23	<u>Horizontal Capture Source Size MSB (R/W) [CAPHSRCSIZE]</u>		
	CapHSrcSizeH	<3:0>	Bits<11:8> of horizontal capture source size
	Reserved	<7:4>	Reserved
24	<u>Horizontal Capture Destination Size LSB (R/W) [CAPHDESTSIZE]</u>		
	CapHDestSizeL	<7:0>	Bits<7:0> of horizontal capture destination size (Unit: 1 pixel)
25	<u>Horizontal Capture Destination Size MSB (R/W) [CAPHDESTSIZE]</u>		
	CapHDestSizeH	<3:0>	Bits<11:8> of horizontal capture destination size
	Reserved	<7:4>	Reserved
26	<u>Vertical Capture Start LSB (R/W) [CAPVSTART]</u>		
	CapVStartL	<7:0>	Bits<7:0> of vertical capture start position (Unit: 1 line)
27	<u>Vertical Capture Start MSB (R/W) [CAPVSTART]</u>		
	CapVStartH	<2:0>	Bits<10:8> of vertical capture start position
	Reserved	<7:4>	Reserved

28	Vertical Capture Source Size LSB (R/W) [CAPVSRCSIZE]		
CapVSrcSizeL	<7:0>	Bits<7:0> of vertical capture source size (Unit: 1 line)	
29	Vertical Capture Source Size MSB (R/W) [CAPVSRCSIZE]		
CapVSrcSizeH	<2:0>	Bits<10:8> of vertical capture source size	
Reserved	<7:4>	Reserved	
2A	Vertical Capture Destination Size LSB (R/W) [CAPVDESTSIZE]		
CapVDestSizeL	<7:0>	Bits<7:0> of vertical capture destination size (Unit: 1 line).	
2B	Vertical Capture Destination Size MSB (R/W) [CAPVDESTSIZE]		
CapVDestSizeH	<2:0>	Bits<10:8> of vertical capture destination size	
Reserved	<7:4>	Reserved	
2E	Interlace Control (R/W) [INTERLACECTR]		
InterlaceEn	<0>	Enable interlace timing input	
FieldCap	<2:1>	Field capture into memory	
		00	Capture even and odd field into memory
		01	Capture odd field only
		10	Capture even field only
		11	Reserved
Fieldoffset	<7:4>	Field capture offset	
30	Horizontal Scale Down Ratio LSB (R/W) [HDNRATIO]		
HDnRatioL	<7:0>	Bits<7:0> of horizontal scale down ratio	
31	Horizontal Scale Down Ratio MSB (R/W) [HDNRATIO]		
HDnRatioH	<0>	Bit<8> of horizontal scale down ratio	
Reserved	<7:1>	Reserved	
32	Vertical Scale Down Ratio LSB (R/W) [VDNRATIO]		
VDnRatioL	<7:0>	Bits<7:0> of vertical scale down ratio	
33	Vertical Scale Down Ratio MSB (R/W) [VDNRATIO]		

VDnRatioH	<0>	Bit<8> of vertical scale down ratio
Reserved	<7:1>	Reserved

Note: HDNRATIO = CAPHDESTSIZE / CAPHSRCsize * 256

VDNRATIO = CAPVDESTSIZE / CAPVSRCSIZE * 256

II. VBI Input timing:

VBI captured data is always been stored in DRAM address, starting at 0.

To Disable VBI capture, set VBIVStart > VBIVEnd, and VBIHStart > VBIHEnd

34 VBI Vertical Start (R/W) [VBIVSTART]

VBIVStart	<7:0>	VBI vertical capture start position
-----------	-------	-------------------------------------

35 VBI Vertical End (R/W) [VBIVEND]

VBIVend	<7:0>	VBI vertical capture end
---------	-------	--------------------------

36 VBI Horizontal Start (R/W) [VBIHSTART]

VBIHStart	<7:0>	VBI horizontal capture start position
-----------	-------	---------------------------------------

37 VBI Horizontal Size (R/W) [VBIVSIZE]

VBIVSize	<7:0>	VBI horizontal capture size
----------	-------	-----------------------------

III. ITU-656 Detection:

38 ITU-656 Hsync Start (R/W) [656HSTART]

656HStart	<7:0>	ITU656data horizontal sync start position, default value 20h
-----------	-------	--

39 ITU-656 Hsync End (R/W) [656HEND]

656HEnd	<7:0>	ITU656data horizontal sync end position, default value 80h
---------	-------	--

3A ITU-656 Vsync Start (R/W) [656VSTART]

656VStart	<7:0>	ITU656data vertical sync start position, default value 02h
-----------	-------	--

3B ITU-656 Vsync End (R/W) [656VEND]

656VEnd <7:0> ITU656data vertical sync end position, default value 04h

IV: Position Detection:

50 Data Threshold for Position Detection (R/W) [POSDATATH]

PosDataTh <7:0> Luma(brightness) threshold value

Note: CAP#50 is used to determine input non-blanking pixel for both horizontal and vertical direction. Any pixel luma value less than this value will be considered as blanking.

52 Horizontal Active Start LSB (R) [POSHDESTART]

PosHDEStartL <7:0> Bits<7:0> of detected horizontal active start position (Unit: 1 pixel)

53 Horizontal Active Start MSB (R) [POSHDESTART]

PosHDEStartH <2:0> Bits<10:8> of detected horizontal active start position

Reserved <7:3> Reserved

54 Horizontal Active End LSB (R) [POSHDEEND]

PosHDEEndL <7:0> Bits<7:0> of detected horizontal active start position (Unit: 1 pixel)

55 Horizontal Active End MSB (R) [POSHDEEND]

PosHDEEndH <2:0> Bits<10:8> of detected horizontal active end position

Reserved <7:3> Reserved

56 Vertical Active Start LSB (R) [POSVDESTART]

PosVDEStartL <7:0> Bits<7:0> of detected vertical active start line (Unit: 1 line)

57 Vertical Active Start MSB (R) [POSVDESTART]

PosVDEStartH <2:0> Bits<10:8> of detected vertical active start line

Reserved <7:3> Reserved

58 Vertical Active End LSB (R) [POSVDEEND]

PosVDEEndL <7:0> Bits <7:0> of detected vertical active end line (Unit: 1 line)

59 Vertical Active End MSB (R) [POSVDEEND]

PosVDEEndH	<2:0>	Bits<10:8> of detected vertical active end line
Reserved	<7:3>	Reserved

V: Mode Detection:

62 Horizontal Capture Total Counter LSB (R) [CAPHTOTALCNT]

CapHtotalCntL	<7:0>	Bits<7:0> of horizontal total count value
---------------	-------	---

63 Horizontal Capture Total Counter MSB (R) [CAPHTOTALCNT]

CapHtotalCntH	<2:0>	Bits<10:8> of horizontal total count value
Reserved	<7:3>	Reserved

64 Vertical Capture Total Counter LSB (R) [CAPVTOTALCNT]

CapVtotalCntL	<7:0>	Bits<7:0> of vertical total count value
---------------	-------	---

65 Vertical Capture Total Counter MSB (R) [CAPVTOTALCNT]

CapVtotalCntH	<2:0>	Bits<10:8> of vertical total count value
Reserved	<7:3>	Reserved

73 Tune Input Clock Phase (R/W) [TUNEINCLK]

TuneInclk	<2:0>	Phase delay number(8 steps)	
	<4:3>	Phase delay types	
		00	Inclk
		01	Inclk + delay phase
		10	Inversed Inclk
	11	Inversed Inclk + delay phase	
Reserved	<7:5>	Reserved	

➤ **Memory Control Group Registers (Accessible when BAS#0E = 02h)**

I.DRAM control

INDEX Register Description

(HEX) Register Name BITS Function Description

20 DRAM Access control (R/W) [DRAMACCESSCTRL]

InputEnable	<0>	Enable input data to DRAM
Reserved	<1>	Reserved
PowerUp	<2>	Enable power up
OutputEnable	<3>	Enable output data from DRAM
Reserved	<4>	Reserved
RefreshEnable	<5>	Enable DRAM refresh
PowerDown	<6>	Enable power down
SetMode	<7>	Enable DRAM setmode cycle

21 DRAM Write (R/W) [DRAMWRITE]

PMCLKSel	<0>	Select DRAM read clock signal path
	0	Internal loop
	1	External loop from pad MCLK to PMCLK
WriteMask1	<1>	Write mask of DRAM byte 0, 1
WriteMask2	<2>	Write mask of DRAM byte 2
SoftRest	<3>	Software Reset
DataDelay	<5:4>	DRAM data delay
DataRdyDelay	<7:6>	DRAM data ready delay

22 Output & FIFO Control (R/W) [OUTFIFOCTRL]

OutputLevel	<3:0>	Output FIFO level control
Reserved	<7:4>	Reserved

23 Input FIFO Control (R/W) [INFIFOCTRL]

InputLevel	<3:0>	Input FIFO level control
Reserved	<7:4>	Reserved

Note: These are DRAM FIFO water mark, when FIFO reach this urgent level, the corresponding video source needs to be serviced(R/W or to/from DRAM)

24~27: Reserved

28 **DRAM Minimum Refresh (R/W) [DRAMMINREFRESH]**

MinRefresh	<7:0>	Minimum refresh requirement within the period of a output VSYNC, usually 1/60 sec
------------	-------	---

29 **DRAM Control 0 (R/W) [DRAMCTRL]**

TRAS	<1:0>	DRAM RAS control signal
		00 5 memory clocks
		01 6 memory clocks
		01 7 memory clocks
		11 8 memory clocks
TRC	<4:2>	DRAM RC control signal
		000 7 memory clocks
		001 8 memory clocks
		001 9 memory clocks
		011 10 memory clocks
		100 11 memory clocks
		101 12 memory clocks
		101 13 memory clocks
		111 14 memory clocks
TRCD	<5>	DRAM RCD control signals
		0 No delay
		1 Delay 1 memory clock
TRP	<6>	DRAM RP control signal
		0 No delay
		1 Delay 1 memory clock
TRPD	<7>	DRAM RPD control signal
		0 No delay
		1 Delay 1 memory clock

2A DRAM Control 1 (R/W) [DRAMCTRL]

TWR	<0>	DRAM WR control signal
	0	No delay
	1	Delay 1 memory clock
TCL	<1>	DRAM CL control signal
	0	No delay
	1	Delay 1 memory clock
TRW	<2>	DRAM RW control signal
	0	No delay
	1	Delay 1 memory clock
MemConfig	<4:3>	SDRAM Size
	00	16Mb
	01	64Mb
	10	Reserved
	11	Reserved
BankConfig	<5>	Bank selector
	0	A22, 0-4M = bank 0, 4-8M = bank 1
	1	A21, 4-6M = bank 0, 6-8M = bank 1
Reserved	<6>	Tie to 1
TXSR	<7>	DRAM XSR control signal

Note: MEM#29&2A is SDRAM timing parameters. Default value: MEM#29="ef", MEM#2A="4f"

2B DRAM Read Address 0 (R/W) [DRAMRADDR]

MemReadAddr0 <7:0> Bits<7:0> of DRAM read address. (unit: 2 pixels)

2C DRAM Read Address 1 (R/W) [DRAMRADDR]

MemReadAddr1 <7:0> Bits<15:8> of DRAM read address

2D DRAM Read Address 2 (R/W) [DRAMRADDR]

MemReadAddr2 <4:0> Bits<20:16> of DRAM read address

Reserved <7:5> Reserved

30 XY Mirror Input (R/W) [XYMIRRORIN]

InputFlipX	<0>	Enable X mirror capture (horizontally captured in the reversed direction)
InputFlipY	<1>	Enable Y mirror capture (vertically captured in the reversed direction, i.e. up side down capture)
Reserved	<7:2>	Reserved

31 XY Mirror Output (R/W) [XYMIRROROUT]

OutputFlipX	<0>	Enable X mirror display (horizontally display in the reversed direction)
OutputFlipY	<1>	Enable Y mirror display (vertically displayed in the reversed direction, i.e. up side down display)
Reserved	<7:2>	Reserved

32 Skip Mode (R/W) [SKIPMODE]

InputSkip	<1:0>	DRAM input address pointer incremental unit 00 2 fields/1 frame stockpile, even1, odd1, even1, odd1, Note: Stride >= size 01 Reserved 10 4 fields/2frames stockpile F1(1),F2(1),F3(1),F4(1),F1(2),F2(2),F3(2)... Note: Stride >= size * 4 11 Reserved
Reserved	<2>	Reserved
TwoField	<3>	Two field mode enable
Reserved	<4>	Reserved
MemControlEn	<5>	0 Disable sdram controller 1 Enable sdram controller
DbufferEn	<6>	Dobule buffering enable
Reserved	<7>	Reserved

II. DRAM input window control

33 DRAM Input Start (R/W) [DRAMINSTART]

DRAMINStart	<7:0>	Input DRAM address start (Unit: 8192 pixels)
-------------	-------	--

34 **DRAM Input Horizontal Stride (R/W) [DRAMINHSTRIDE]**

DRAMINHStride <7:0> Input DRAM horizontal stride (Unit: 4 pixels)

35 **DRAM Input Horizontal Size (R/W) [DRAMINHSIZE]**

DRAMINHSize <7:0> Input DRAM horizontal size (Unit: 4 pixels)

Note: Set stride value at 64/128/256 boundary, will better ease DRAM timing.

DRAMINHSIZE = CAPHDESTSIZE(CAP#25&24) / 4

III. DRAM window copy control

39 **Window Copy Source Start LSB (R/W) [WCSRCSTART]**

GSInputStart1 <7:0> Bits<7:0> of GS input DRAM address start. (Unit: 8192 pixels)

3A **Window Copy Source Start (R/W) [WCSRCSTART]**

GSInputStart2 <7:0> Bits<15:8> of GS input DRAM address start

3B **Window Copy Source Start MSB (R/W) [WCSRCSTART]**

GSInputStart3 <3:0> Bits<18:16> of GS input DRAM address start

Reserved <7:4> Reserved

3C **Window Copy Source Stride (R/W) [GSDRAMINPUTSTRIDE]**

GSIStride <7:0> GS input DRAM stride. (8 pixels)

3D **Window Copy Size (R/W) [GSDRAMINPUTSIZE]**

GSHSize <7:0> GS input DRAM size. (Unit: 8 pixels)

3E **Direct Write Stride (R/W) [WCSTRIDE]**

WCStride <7:0> DRAM window copy stride. (Unit: 8 pixels)

3F **Window Copy Destination Start LSB (R/W) [WCDESTSTART]**

WCSrcStart1 <7:0> Bits<7:0> of DRAM window copy source address start. (Unit: 8 pixels)

40 Window Copy Destination Start (R/W) [WCDESTSTART]
WCDestStart2 <7:0> Bits<15:8> of DRAM window copy source address start

41 Window Copy Destination Start MSB (R/W) [WCDESTSTART]
WCDestStart3 <3:0> Bits<20:16> of DRAM window copy source address start
Reserved <7:4> Reserved

Note: After writing to MEM#41, the Window Copy operation will be carried out.

42 Direct Read/Write Address LSB (R/W) [DASTART]
DAddrStart1 <7:0> Bits<7:0> of DRAM window copy source address start. (Unit: 8 pixels)

43 Direct Read/Write Address (R/W) [DASTART]
DAddrStart2 <7:0> Bits<15:8> of DRAM window copy source address start

44 Direct Read/Write Address MSB (R/W) [DASTART]
DAddrStart3 <3:0> Bits<20:16> of DRAM window copy source address start
Reserved <7:4> Reserved

45 Window Copy Size (R/W) [WCSIZE]
WCSize <7:0> DRAM Directly Write size. (Unit: 8 pixels) or DRAM window copy total lines [7:0] for Window Copy.

46 Window Copy Line Total (R/W) [WCLINETOTAL]
WCLineTotal <7:0> DRAM window copy total lines[2:0]. (1 line)

IV. DRAM output window control

47 DRAM Output Start (R/W) [DRAMOUTSTART]
DRAMOutStart <7:0> Output DRAM address start. (Unit: 8192 pixels)

48 DRAM Output Horizontal Stride (R/W) [DRAMOUTHSTRIDE]

DRAMOutHStride <7:0> Output DRAM horizontal stride. (Unit: 4/8/12 pixels)

49 DRAM Output Horizontal Size (R/W) [DRAMOUTHSIZE]

DRAMOutHSize <7:0> Output DRAM horizontal size. (Unit: 4/8/12 pixels)

DRAMOHSIZE = DISHSRCSIZE(DIS#41&40) / 4

4D VBI Start Address LSB (R/W) [VBISTART]

VBIAddrStart1 <7:0> Bit<7:0> of VBI starting address.

4E VBI Start Address (R/W) [VBISTART]

VBIAddrStart2 <7:0> Bit<15:8> of VBI starting address.

4F VBI Start Address MSB (R/W) [VBISTART]

VBIAddrStart3 <3:0> Bit<19:16> of VBI starting address.

Reserved <7:4> Reserved

50 Front Motion Detect Control (R/W) [FRONTM]

FrontMYth <6:0> Y threshold Value for Front Motion

EnFrontM <7> Enable Front Motion Detection

51 Tune Memory Write Clock Phase (R/W) [TUNEMCLK]

TuneMclk <2:0> Phase delay number(8 steps)

<4:3> Phase delay types

00 Mclk

01 Mclk + delay phase

10 Inversed Mclk

11 Inversed Mclk + delay phase

Reserved <7:5> Reserved

52 Tune Memory Read Clock Phase (R/W) [TUNEPMCLK]

TunePMclk <2:0> Phase delay number(8 steps)

<4:3> Phase delay types

00 PMclk

		01	PMclk + delay phase
		10	Inversed PMclk
		11	Inversed PMclk + delay phase
Reserved	<7:5>	Reserved	

V. DRAM data port

60 Read Status (R) [READSTATUS]

Status	<0>	Data Ready
Reserved	<7:1>	Reserved

61 Byte 0 (R)(W) [BYTE0]

RByte0(R)	<7:0>	Bits<7:0> of DRAM for read-out
WByte0(W)	<7:0>	Bits<7:0> of Pixel 0 for 16-bit mode Write, or Dummy field for 24-bit mode Write

62 Byte 1 (R)(W) [BYTE1]

RByte1(R)	<7:0>	Bits<15:8> of DRAM read-out
WByte1(W)	<7:0>	Bits<15:8> of Pixel 0 for 16-bit mode Write, or Blue field for 24-bit mode Write

63 Byte 2 (R)(W) [BYTE2]

RByte2(R)	<7:0>	Bits<23:16> of DRAM read-out
WByte2(W)	<7:0>	Bits<7:0> of Pixel 1 for 16-bit mode Write, or Green field for 24-bit mode Write

64 Byte 3 (R)(W) [BYTE3]

RByte3(R)	<7:0>	Bits<31:24> of DRAM read-out
WByte3(W)	<7:0>	<15:8> of Pixel 1 for 16-bit mode Write, or Red field for 24-bit mode Write

65 Byte 4 (R) [BYTE4]

RByte4	<7:0>	Bits<39:32> of DRAM read-out
--------	-------	------------------------------

66 Byte5 (R) [BYTE5]

RByte4 <7:0> Bits<47:40> of DRAM read-out

DRAM data read ports are defined in MEM#61~66. MemReadAddr is defined in MEM#42~44. After reading MEM#60, the read cycle will be strobe if bit-0 is 0. MEM#60 should be read until bit 0 is 1. Then, read MEM#61~66 for the data read from SDRAM.

➤ **Display Control Group Registers (Accessible when BAS#0E = 03h)**

I. Display Timing

INDEX	Register Description		
(HEX)	Register Name	BITS	Function Description
20	Horizontal Display Total LSB (R/W) [DISHTOTAL]		
	DisHTotalL	<7:0>	Bits<7:0> of display horizontal total (Unit: 1 pixel)
21	Horizontal Display Total MSB (R/W) [DISHTOTAL]		
	DisHTotalH	<3:0>	Bits<11:8> of display horizontal total
	Reserved	<7:4>	Reserved
22	Horizontal Display Sync LSB (R/W) [DISHSEND]		
	DishSEndL	<7:0>	Bits<7:0> of display horizontal sync end (Unit: 1 pixel)
23	Horizontal Display Sync MSB (R/W) [DISHSEND]		
	DishSEndH	<3:0>	Bits<11:8> of display horizontal sync end
	Reserved	<7:4>	Reserved
Note: Horizontal sync start at position 1.			
24	Horizontal Display Start LSB (R/W) [DISHDESTART]		
	DishDEStartL	<7:0>	Bits<7:0> of horizontal display start (Unit: 1 pixel)
25	Horizontal Display Start MSB (R/W) [DISHDESTART]		
	DishDEStartH	<3:0>	Bits<11:8> of horizontal display start
	Reserved	<7:4>	Reserved
26	Horizontal Display End LSB (R/W) [DISHDEEND]		
	DishDEEndL	<7:0>	Bits<7:0> of horizontal display end (Unit: 1 pixel)
27	Horizontal Display End MSB (R/W) [DISHDEEND]		
	DishDEEndH	<3:0>	Bits<11:8> of horizontal display end

	Reserved	<7:4>	Reserved
28	Display Vertical Total LSB (R/W) [DISVTOTAL]		
	DisVTotalL	<7:0>	Bits<7:0> of display vertical total (Unit: 1 pixel)
29	Display Vertical Total MSB (R/W) [DISVTOTAL]		
	DisVTotalH	<3:0>	Bits <11:8> of display vertical total
	Reserved	<7:4>	Reserved
2A	Display Vertical Sync LSB (R/W) [DISVSEND]		
	DisVSEndL	<7:0>	Bits<7:0> of display vertical sync end (Unit: 1 pixel)
2B	Display Vertical Sync MSB (R/W) [DISVSEND]		
	DisVSEndH	<3:0>	Bits<11:8> of display vertical sync end
	Reserved	<7:4>	Reserved
Note: Vertical sync start at line 1.			
2C	Vertical Display Start LSB (R/W) [DISVDESTART]		
	DisVDEStartL	<7:0>	Bits<7:0> of vertical display start (Unit: 1 pixel)
2D	Vertical Display Start MSB (R/W) [DISVDESTART]		
	DisVDEStartH	<3:0>	Bits<11:8> of vertical display start
	Reserved	<7:4>	Reserved
2E	Vertical Display End LSB (R/W) [DISVDEEND]		
	DisVDEEndL	<7:0>	Bits<7:0> of vertical display end (Unit: 1 pixel)
2F	Vertical Display End MSB (R/W) [DISVDEEND]		
	DisVDEEndH	<3:0>	Bits<11:8> of vertical display end
	Reserved	<7:4>	Reserved

II. Window Output Timing

30 Horizontal Display Active Start LSB (R/W) [DISHDESTART]

DisHDEStartL <7:0> Bits<7:0> of horizontal display active start (Unit: 1 pixel)

31 Horizontal Display Active Start MSB (R/W) [DISHDESTART]

DisHDEStartH <3:0> Bits<11:8> of horizontal display active start

Reserved <7:4> Reserved

32 Horizontal Display Active End LSB (R/W) [DISHDEEND]

DisHDEEndL <7:0> Bits<7:0> of horizontal display active end (Unit: 1 pixel)

33 Horizontal Display Active End MSB (R/W) [DISHDEEND]

DisHDEEndH <3:0> Bits<11:8> of horizontal display active end

Reserved <7:4> Reserved

34 Vertical Display Active Start LSB (R/W) [DISVDESTART]

DisVDEStartL <7:0> Bits<7:0> of vertical display active start (Unit: 1 pixel)

35 Vertical Display Active Start MSB (R/W) [DISVDESTART]

DisVDEStartH <3:0> Bits<11:8> of vertical display active start

Reserved <7:4> Reserved

36 Vertical Display Active End LSB (R/W) [DISVDEEND]

DisVDEEndL <7:0> Bits<7:0> of vertical display active end (Unit: 1 pixel)

37 Vertical Display Active End MSB (R/W) [DISVDEEND]

DisVDEEndH <3:0> Bits<11:8> of vertical display active end

Reserved <7:4> Reserved

III. Zoom In Control Registers

40 Horizontal Display Source Size LSB (R/W) [DISHSRCSIZE]

DisHSrcSizeL <7:0> Bits<7:0> of horizontal display source size (Unit: 1 pixel)

41 Horizontal Display Source Size MSB (R/W) [DISHSRCSIZE]

DisHSrcSizeH	<3:0>	Bits<11:8> of horizontal display source size
Reserved	<7:4>	Reserved

42 Horizontal Display Destination Size LSB (R/W) [DISHDESTSIZE]

DisHDestSizeL	<7:0>	Bits<7:0> of horizontal display destination size (Unit: 1 pixel).
---------------	-------	---

43 Horizontal Display Destination Size MSB (R/W) [DISHDESTSIZE]

DisHDestSizeH	<3:0>	Bits<11:8> of horizontal display destination size
Reserved	<7:4>	Reserved

44 Vertical Display Source Size LSB (R/W) [DISVSRCSIZE]

DisVSrcSizeL	<7:0>	Bits<7:0> of vertical display source size (Unit:1 pixel)
--------------	-------	--

45 Vertical Display Source Size MSB (R/W) [DISVSRCSIZE]

DisVSrcSizeH	<3:0>	Bits<11:8> of vertical display source size
Reserved	<7:4>	Reserved

46 Vertical Display Destination Size LSB (R/W) [DISVDESTSIZE]

DisVDestSizeL	<7:0>	Bits<7:0> of vertical display source size (Unit:1 pixel)
---------------	-------	--

47 Vertical Display Destination Size MSB (R/W) [DISVDESTSIZE]

DisVDestSizeH	<3:0>	Bits<11:8> of vertical display destination size
Reserved	<7:4>	Reserved

Note : DISHDESTSIZE >= DISHSRCSIZE, DISVDESTSIZE >= DISVSRCSIZE

48 Zoom In Filter Control (R/W) [ZOOMFCTRL]

VZoomEn	<0>	Enable vertical scale-up filtering
HZoomEn	<1>	Enable horizontal scale-up filtering
Reserved	<7:2>	Reserved

4A Horizontal Scale Up Ratio LSB (R/W) [HUPRATIO]

HUpRatioL	<7:0>	Bits<7:0> of horizontal scale up ratio
-----------	-------	--

4B Horizontal Scale Up Ratio MSB (R/W) [HUPRATIO]

HUpRatioH <7:0> Bits<15:8> of horizontal scale up ratio

4A Delta Horizontal Scale Up Ratio LSB (R/W) [DELTAHUPRATIO]

DeltaHUpRatioL <7:0> Bits<7:0> delta of horizontal scale up ratio for Keystone

4B Delta Horizontal Scale Up Ratio MSB (R/W) [DELTAHUPRATIO]

DeltaHUpRatioH <3:0> Bits<11:8> delta of horizontal scale up ratio for Keystone

HDEStartInc <5:4> Delta of starting point of horizontal DE for Keystone

00 Added by 0

01 Added by 1

10 Added by 0

11 Substrate by 1

HDEEndInc <7:6> Delta of Ending point of horizontal DE for Keystone

00 Added by 0

01 Added by 1

10 Added by 0

11 Substrate by 1

Note: This definition is valid when DIS#CB<4>='1' and used in Keystone

4C Vertical Scale Up Ratio LSB (R/W) [VUPRATIO]

VUpRatioL <7:0> Bits<7:0> of vertical scale up ratio

4D Vertical Scale Up Ratio MSB (R/W) [VUPRATIO]

VUpRatioH <7:0> Bits<15:8> of vertical scale up ratio

Note: HUPRATIO = DISHSRCSIZE / DISHDESTSIZE * 8192

Note: VUPRATIO = DISVSRCSIZE / DISVDESTSIZE * 8192

4E Horizontal Scale Up Initial Phase LSB (R/W) [HPHASE]

HUpPhaseL <7:0> Bit<7:0> of horizontal scale up initial phase

4F Horizontal Scale Up Initial Phase MSB (R/W) [HPHASE]

HUpPhaseH <7:0> Bit<15:8> of horizontal scale up initial phase

50	Vertical Scale Up Initial Phase LSB (R/W) [VPHASE]		
	VUpPhaseL	<7:0>	Bit<7:0> of vertical scale up initial phase
51	Vertical Scale Up Initial Phase MSB (R/W) [VPHASE]		
	VUpPhaseH	<7:0>	Bit<15:8> of vertical scale up initial phase
54	Output Mode (R/W) [OUTPUTMODE]		
	OutputMode	<1:0>	Output enable
		00	Enable
		01	Reserved
		10	Reserved
		11	Disable, Zero output
	Reserved	<4:2>	Reserved
	DitherMode	<5>	Enable dither output
		0	No dither
		1	8 bits to 6 bits
	Reserved	<6>	Reserved
	LutEn	<7>	Enable built-in LUT look-up table
55	LUT Write Index (R/W) [LUTWINDEX]		
	LUTWIndex	<7:0>	LUT access index
5C	LUT Red Color LSB (R/W) [LUTRED]		
	LUTRed	<7:0>	LUT red color port
5D	LUT Green Color LSB (R/W) [LUTGREEN]		
	LUTGreen	<7:0>	LUT green color port
5E	LUT Blue Color LSB (R/W) [LUTBLUE]		
	LUTBlue	<7:0>	LUT blue color port
5F	LUT Read/Write Trigger (R/W) [LUTWEN]		
	Reserved	<5:0>	Reserved

LUTWEn	<7:6>	Write color field enable
	00	Red, Green and Blue written into LUT
	01	Only Red is written into LUT
	10	Only Green written into LUT
	11	Only Blue written into LUT

56 Pattern Generator and GPO (R/W) [PATTERNGEN]

PatternMode	<1:0>	00	Fram line
		01	Color bar
		10	Gray level
		11	Line moier
PatternEn	<4>		Enable pattern generation
GPO	<7:5>		General purpose output port

Note: Set register GPO(DIS#56<7:5>) value will effect pin GPO2~0 output status in phase

IV. OSD Color Registers

58 OSD Write Address LSB (R/W) [OSDRAMWADDR]

OSDRamWAddrL	<7:0>	Bit<7:0> of OSD ram write address
--------------	-------	-----------------------------------

59 OSD Write Address MSB (R/W) [OSDRAMWADDR]

OSDRamWAddrH	<2:0>	Bit<10:8> of OSD ram write address
Reserved	<7:3>	Reserved

5A OSD Write Data Port (W) [OSDRAMWDATA]

OSDWData	<7:0>	OSD ram write data port
----------	-------	-------------------------

60 Color 0 Red (R/W) [COLOR0RED]

Color0Red	<7:0>	Color 0 Red Component
-----------	-------	-----------------------

61 Color 0 Green (R/W) [COLOR0GREEN]

Color0Green	<7:0>	Color 0 Green Component
-------------	-------	-------------------------

62	Color 0 Blue (R/W) [COLOR0RED]
Color0Blue	<7:0> Color 0 Blue Component
63	Color 1 Red (R/W) [COLOR1RED]
Color1Red	<7:0> Color 1 Red Component
64	Color 1 Green (R/W) [COLOR1GREEN]
Color1Green	<7:0> Color 1 Green Component
65	Color 1 Blue (R/W) [COLOR1BLUE]
Color1Blue	<7:0> Color 1 Blue Component
66	Color 2 Red (R/W) [COLOR2RED]
Color2Red	<7:0> Color 2 Red Component
67	Color 2 Green (R/W) [COLOR2GREEN]
Color2Green	<7:0> Color 2 Green Component
68	Color 2 Blue (R/W) [COLOR2BLUE]
Color2Blue	<7:0> Color 2 Blue Component
69	Color 3 Red (R/W) [COLOR3RED]
Color3Red	<7:0> Color 3 Red Component
6A	Color 3 Green (R/W) [COLOR3GREEN]
Color3Green	<7:0> Color 3 Green Component
6B	Color 3 Blue (R/W) [COLOR3BLUE]
Color3Blue	<7:0> Color 3 Blue Component
6C	Color 4 Red (R/W) [COLOR4RED]
Color4Red	<7:0> Color 4 Red Component
6D	Color 4 Green (R/W) [COLOR0GREEN]

Color4Green <7:0> Color 4 Green Component

6E Color 4 Blue (R/W) [COLOR4BLUE]

Color4Blue <7:0> Color 4 Blue Component

6F Color 5 Red (R/W) [COLOR5RED]

Color5Red <7:0> Color 5 Red Component

70 Color 5 Green (R/W) [COLOR5GREEN]

Color5Green <7:0> Color 5 Green Component

71 Color 5 Blue (R/W) [COLOR5BLUE]

Color5Blue <7:0> Color 5 Blue Component

72 Color 6 Red (R/W) [COLOR6RED]

Color6Red <7:0> Color 6 Red Component

73 Color 6 Green (R/W) [COLOR6GREEN]

Color6Green <7:0> Color 6 Green Component

74 Color 6 Blue (R/W) [COLOR6BLUE]

Color6Blue <7:0> Color 6 Blue Component

75 Color 7 Red (R/W) [COLOR7RED]

Color7Red <7:0> Color 7 Red Component

76 Color 7 Green (R/W) [COLOR7GREEN]

Color7Green <7:0> Color 7 Green Component

77 Color 7 Blue (R/W) [COLOR7BLUE]

Color7Blue <7:0> Color 7 Blue Component

V. OSD Control Register

78 OSD Color Select (R/W) [OSDCOLORSEL]

Osd1ColorSel	<1:0>	OSD1 color selection, 8 colors only apply when Font2byte= '1' and PixDepth1= '1'
	00	select OSD1 colors from index 3..0
	01	select OSD1 colors from index 7..4
	10	select OSD1 colors from index 7..0
	11	Reserved
Osd2ColorSel	<3:2>	OSD2 color selection, 8 colors only apply when Font2byte= '1' and PixDepth2= '1'
	00	select OSD2 colors from index 3..0
	01	select OSD2 colors from index 7..4
	10	select OSD2 colors from index 7..0
	11	Reserved
Font2byte	<4>	Two-byte font charter code mode, effective only when RomMode = '1'
Reserved	<7:5>	Reserved

79 Blink Time (R/W) [BLINKTIME]

BlinkTimer	<6:0>	Blinking timing value
BlinkType	<7>	0 Reverse color
		1 Bypass

Note: OSD Blinking frequency = Vsync frequency / BlinkTimer

80 OSD Modes (R/W) [OSDMODE]

RomMode	<0>	Enable ROM mode
	0	Internal RAM mode
	1	External ROM mode
Reserved	<1>	Tie to 0
Number	<7:2>	Adjust rom address width to access external rom data

Note: The method of select the Number value show on OSD application note

81 Logic Operation (R/W) [FOREOP]

Color0Op	<1:0>	Logic operation between color 0 and video
	00	NOP, show only OSD
	01	OR, video or color 0
	10	AND, video and color 0
	11	XOR, video xor color 0
Color1Op	<3:2>	Logic operation between color 1 and video
	00	NOP, show only OSD
	01	OR, video or color 1
	10	AND, video and color 1
	11	XOR, video xor color 1
Color2Op	<5:4>	Logic operation between color 2 and video
	00	NOP, show only OSD
	01	OR, video or color 2
	10	AND, video and color 2
	11	XOR, video xor color 2
Color3Op	<7:6>	Logic operation between color 3 and video
	00	NOP, show only OSD
	01	OR, video or color 3
	10	AND, video and color 3
	11	XOR, video xor color 3

83 Logic Operation (R/W) [FOREOP]

Color4Op	<1:0>	Logic operation between color 4 and video
	00	NOP, show only OSD
	01	OR, video or color 4
	10	AND, video and color 4
	11	XOR, video xor color 4
Color5Op	<3:2>	Logic operation between color 5 and video
	00	NOP, show only OSD
	01	OR, video or color 5
	10	AND, video and color 5
	11	XOR, video xor color 5
Color6Op	<5:4>	Logic operation between color 6 and video
	00	NOP, show only OSD

		01	OR, video or color 6
		10	AND, video and color 6
		11	XOR, video xor color 6
Color7Op	<7:6>		Logic operation between color 7 and video
		00	NOP, show only OSD
		01	OR, video or color 7
		10	AND, video and color 7
		11	XOR, video xor color 7

Note: Color 0 ~ 7 are defined in DIS#60~77.

82 Fading Alpha Value (R/W) [FADEALPHA]

FadeAlpha	<5:0>	The alpha factor for fading effect ranging
Reserved	<7:6>	Reserved

Note: FADEALPHA range from 00h to 20h, there is 33-level of fade-in/fade-out effect.

Output = Image * FADEALPHA/32 + OSD * (1 - (FADEALPHA /32))

Show only OSD: FADEALPHA = "000000" --- minimum alpha value(00h)

Show only Image: FADEALPHA = "100000" --- maximum alpha value(20h)

VI. OSD 1 Registers

84 OSD1 Control (R/W) [OSDCONTROL1]

PixDepth1	<0>	Number of bits per pixel of OSD1
		0 One bit per pixel
		1 Two bits per pixel
BlinkEn1	<1>	OSD1 blinking enable, effective when RomMode = '1'
		0 Disable blinking
		1 Enable blinking
HZoom1	<3:2>	OSD1 horizontal zoom factor
		00 OSD1 pixel H size equals to 1X of video pixel
		01 OSD1 pixel H size equals to 2X of video pixel
		10 OSD1 pixel H size equals to 4X of video pixel
		11 OSD1 pixel H size equals to 8X of video pixel

VZoom1	<5:4>	OSD1 vertical zoom factor
	00	OSD1 pixel V size equals to 1X of video pixel
	01	OSD1 pixel V size equals to 2X of video pixel
	10	OSD1 pixel V size equals to 4X of video pixel
	11	OSD1 pixel V size equals to 8X of video pixel
Reserved	<6>	Reserved
OsdEn1	<7>	OSD1 enable
	0	Disable OSD1
	1	Enable OSD1

85 **OSD1 ROM Start Address (R/W) [ROMSTARTADDR1]**

RomStAddr1H	<7:0>	Bits<11:4> of OSD1 ROM start address (Unit: 16 bytes)
-------------	-------	---

86 **OSD1 Font Address Unit (R/W) [FONTADDRUNIT1]**

RomStAddr1L	<3:0>	Bits<3:0> OSD1 ROM start address (Unit: 16 bytes)
FontAddrUnit1	<7:4>	OSD1 font address unit (n), font address is multiple of 2(n+5) bytes, max. is 216

90 **OSD1 Horizontal Start (R/W) [OSDHSTART1]**

OsdHStart1	<7:0>	On Screen Display horizontal start position (Unit: 8 video pixels)
------------	-------	--

91 **OSD1 Vertical Start (R/W) [OSDVSTART1]**

OsdVStart1	<7:0>	On Screen Display vertical start position (Unit: 4 video lines)
------------	-------	---

92 **OSD1 RAM Start Address (R/W) [RAMADDRST1]**

RamAddrSt1	<7:0>	OSD1 RAM start address (Unit: 8 bytes)
------------	-------	--

8B **OSD1 RAM Horizontal Stride MSB (R/W) [RAMSTRIDE1]**

RamStride1H	<1:0>	Bits <9:8> of OSD1 RAM line stride (Unit: 1 bytes)
Reserved	<7:2>	Reserved

93 **OSD1 RAM Horizontal Stride LSB (R/W) [RAMSTRIDE1]**

RamStride1L	<7:0>	Bits<7:0> of OSD1 RAM line stride(Unit: 1 bytes)
-------------	-------	--

94	OSD1 Bitmap Horizontal Size LSB (R/W) [BMAPHSIZE1]
BmapHSize1L	<7:0> Bits<7:0> of OSD1 horizontal bitmap size (Unit: 1 OSD pixel)
95	OSD1 Bitmap Horizontal Size MSB (R/W) [BMAPHSIZE1]
BmapHSize1H	<1:0> Bits<9:8> of OSD1 bitmap horizontal size
Reserved	<7:2> Reserved
96	OSD1 Bitmap Horizontal Total Pixels LSB (R/W) [BMAPHTOTAL1]
BmapHTotal1L	<7:0> Bits<7:0> of OSD1 bitmap horizontal total (Unit: 1 OSD pixel)
97	OSD1 Bitmap Horizontal Total Pixels MSB (R/W) [BMAPHTOTAL1]
BmapHTotal1H	<1:0> Bits<9:8> of OSD1 bitmap horizontal total
Reserved	<7:2> Reserved
98	OSD1 Bitmap Vertical Size LSB (R/W) [BMAPVSIZE1]
BmapVSize1L	<7:0> Bits<7:0> of OSD1 bitmap vertical size (Unit: 1 OSD line)
99	OSD1 Bitmap Vertical Size MSB (R/W) [BMAPVSIZE1]
BmapVSize1H	<1:0> Bits<9:8> of OSD1 bitmap vertical size
Reserved	<7:2> Reserved
9A	OSD1 Bitmap Vertical total Lines LSB (R/W) [BMAPVTOTAL1]
BmapVTotal1L	<7:0> Bits<7:0> of OSD1 bitmap vertical total (Unit: 1 OSD line)
9B	OSD1 Bitmap Vertical Total Lines MSB (R/W) [BMAPVTOTAL1]
BmapVTotal1H	<1:0> Bits<9:8> of OSD1 bitmap vertical total
Reserved	<7:2> Reserved
9C	OSD1 Icon Horizontal Total (R/W) [ICONHTOTAL1]
IconHtotal1	<7:0> OSD1 horizontal icon total (Unit: 1 icon)
9D	OSD1 Icon Vertical Total (R/W) [ICONVTOTAL1]
IconVTotal1	<7:0> OSD1 vertical icon total (Unit: 1 icon)

AE OSD1 Font Line Size (R/W) [FONTLINESIZE1]

Fontlinesize1	<7:0>	memory size of a line of font (Unit: 1 byte)
---------------	-------	--

VII. OSD 2 Registers

88 OSD2 Control (R/W) [OSDCONTROL2]

PixDepth2	<0>	Number of bits per pixel of OSD2
		0 One bit per pixel
		1 Two bits per pixel
BlinkEn2	<1>	OSD2 blinking enable, effective when RomMode = '1'
		0 Disable blinking
		1 Enable blinking
Hzoom2	<3:2>	OSD2 horizontal zoom factor
		00 OSD pixel H size equals to 1X of video pixel
		01 OSD pixel H size equals to 2X of video pixel
		10 OSD pixel H size equals to 4X of video pixel
		11 OSD pixel H size equals to 8X of video pixel
Vzoom2	<5:4>	OSD2 vertical zoom factor
		00 OSD pixel V size equals to 1X of video pixel
		01 OSD pixel V size equals to 2X of video pixel
		10 OSD pixel V size equals to 4X of video pixel
		11 OSD pixel V size equals to 8X of video pixel
Reserved	<6>	Reserved
OsdEn2	<7>	OSD2 enable
		0 Disable OSD2
		1 Enable OSD2

89 OSD2 ROM Start Address (R/W) [ROMSTARTADDR2]

RomStAddr1H	<7:0>	Bits<11:4> of OSD2 ROM start address (Unit: 16 bytes)
-------------	-------	---

8A OSD2 Font Address Unit (R/W) [FONTADDRUNIT2]

RomStAddr2L	<3:0>	Bits<3:0> OSD2 ROM start address (Unit: 16 bytes)
FontAddrUnit2	<7:4>	OSD1 font address unit (n), font address is multiple of 2(n+5) bytes, max. is 216

A0	OSD2 Horizontal Start (R/W) [OSDHSTART2]		
	OsdHStart2	<7:0>	On Screen Display horizontal start position (Unit: 8 video pixels)
A1	OSD2 Vertical Start (R/W) [OSDVSTART1]		
	OsdVStart2	<7:0>	On Screen Display vertical start position (Unit: 4 video lines)
A2	OSD2 RAM Start Address (R/W) [RAMADDRST2]		
	RamAddrSt2	<7:0>	OSD2 RAM start address (Unit: 8 bytes)
8C	OSD2 RAM Horizontal Stride MSB (R/W) [RAMSTRIDE2]		
	RamStride2H	<1:0>	Bits <9:8> of OSD2 RAM line stride (Unit: 1 bytes)
	Reserved	<7:2>	Reserved
A3	OSD2 RAM Horizontal Stride LSB (R/W) [RAMSTRIDE2]		
	RamStride2L	<7:0>	Bits<7:0> of OSD2 RAM line stride (Unit: 1 bytes)
A4	OSD2 Bitmap Horizontal Size LSB (R/W) [BMAPHSIZE2]		
	BmapHSize2L	<7:0>	Bits<7:0> of OSD1 horizontal bitmap size (Unit: 1 OSD pixel)
A5	OSD2 Bitmap Horizontal Size MSB (R/W) [BMAPHSIZE2]		
	BmapHSize2H	<1:0>	Bits<9:8> of OSD1 bitmap horizontal size
	Reserved	<7:2>	Reserved
A6	OSD2 Bitmap Horizontal Total Pixels LSB (R/W) [BMAPHTOTAL2]		
	BmapHTotal2L	<7:0>	Bits<7:0> of OSD2 bitmap horizontal total (Unit: 1 OSD pixel)
A7	OSD2 Bitmap Horizontal Total Pixels MSB (R/W) [BMAPHTOTAL2]		
	BmapHTotal2H	<1:0>	Bits<9:8> of OSD2 bitmap horizontal total
	Reserved	<7:2>	Reserved
A8	OSD2 Bitmap Vertical Size LSB (R/W) [BMAPVSIZE2]		
	BmapVSize2L	<7:0>	Bits<7:0> of OSD2 bitmap vertical size (Unit: 1 OSD line)

A9	OSD2 Bitmap Vertical Size MSB (R/W) [BMAPVSIZE2]
BmapVSize2H	<1:0> Bits<9:8> of OSD2 bitmap vertical size
Reserved	<7:2> Reserved

AA	OSD2 Bitmap Vertical total Lines LSB (R/W) [BMAPVTOTAL2]
BmapVTotal2L	<7:0> Bits<7:0> of OSD2 bitmap vertical total(Unit: 1 OSD line)

AB	OSD2 Bitmap Vertical Total Lines MSB (R/W) [BMAPVTOTAL2]
BmapVTotal2H	<1:0> Bits<9:8> of OSD2 bitmap vertical total
Reserved	<7:2> Reserved

AC	OSD2 Icon Horizontal Total (R/W) [ICONHTOTAL2]
IconHtotal2	<7:0> OSD2 horizontal icon total (Unit: 1 icon)

AD	OSD2 Icon Vertical Total (R/W) [ICONVTOTAL2]
IconVTotal2	<7:0> OSD2 vertical icon total (Unit: 1 icon)

AF	OSD2 Font Line Size (R/W) [FONTLINESIZE2]
Fontlinesize2	<7:0> memory size of a line of font (Unit: 1 byte)

VIII. Desktop Color Registers

B3	Desktop Color Component Red (R/W) [DESKR]
DeskColorRed	<7:0> Desktop color red

B4	Desktop Color Component Green (R/W) [DESKG]
DeskColorGreen	<7:0> Desktop color green

B5	Desktop Color Component Blue (R/W) [DESKB]
DeskColorBlue	<7:0> Desktop color blue

IX. Film Detection/Motion Adaptive Registers

C4	Motion Pixels Threshold LSB (R/W) [MOTIONCNTTH]
-----------	--

	MvCntThL	<7:0>	Bit<7:0> of motion counter threshold
<hr/>			
C5	Motion Pixels Threshold MSB (R/W) [MOTIONCNTTH]		
	MvCntThH	<7:0>	Bit<15:8> of motion counter threshold
<hr/>			
C6	Lumina(Y) Threshold (R/W) [LUMATH]		
	YThL	<6:0>	Y threshold for film & motion compensation
	Reserved	<7>	Reserved
<hr/>			
C7	Chroma(C) Threshold (R/W) [CHROMATH]		
	CThH	<6:0>	C threshold for film & motion compensation
	Reserved	<7>	Reserved
<hr/>			
C8	De-interlacing Control Register(R/W) [MCCTRL]		
	MCEn	<0>	Motion Compensation Enable
		0	Field Merge De-interlace Mode
		1	Motion Adaptive De-interlace Mode
	MvMode	<1>	Motion Estimation Type
		0	Y/C Comparison
		1	Y Comparison Only
	Reserved	<2>	Reserved
	TestMv	<3>	Display Motion Part
	Reserved	<7:4>	Reserved
<hr/>			
C9	Film Detection Control Register(R/W) [FILMCTRL]		
	FilmDetEn	<0>	Film detection enable
		0	Disable
		1	Enable
	ResetType	<1>	Non-Film Detection Type
		0	H/W Auto Detection
		1	S/W Reset to Non-Film after Film Detected
	FilmReset	<2>	Reset Film Detection, depending on bit1
		0	Disable Reset
		1	Reset when bit 1 is turn on

Reserved	<3>	Reserved
PdMatch	<7:4>	Number of film sequence matched

CE Motion Pixel Numbers LSB (R) [MVCNT]

MvCountL	<7:0>	Bit<7:0> of pixels numbers of difference between 2-field/frame
----------	-------	--

CF Motion Pixel Numbers MSB (R) [MVCNT]

MvCountH	<7:0>	Bit<15:8> of pixels numbers of difference between 2-field/frame
----------	-------	---

X. Keystone/Sharpness Registers

CB Keyston/Sharpness Control Register(R/W) [SHPKEYCTRL]

ShapEn	<0>	Sharpness enable
		0 Disable
		1 Enable
KeyEn	<4>	Keystone enable
		0 Disable
		1 Enable
Interlace	<5>	Interlace output enable
EvenField	<6>	Even field mode
TriLevel	<7>	Tri level analog data output enable

C0 Keystone Parameters Address LSB (R/W) [KEYADDR]

KeyAddrL	<7:0>	Bit<7:0> of keystone FIFO address
----------	-------	-----------------------------------

C1 Keystone Parameters Address MSB (R/W) [KEYADDR]

KeyAddrH	<3:0>	Bit<11:8> of keystone FIFO address
Reserved	<6:4>	Reserved
KeyWriteEn	<7>	Keystone fifo write enable
		0 Disable
		1 Enable

Note: Keystone parameter for each scan line is stored into 1280x32 SRAM inside AL310. KeyAddr is the address of read/write pointer of this SRAM.

XI. Tri-Level Sync Registers

D0	Tri Level Sync Parameter (W) [TRISYNCA]		
PeriodA	<7:0>	Tri level sync parameter Period_a	
D1	Tri Level Sync Parameter (W) [TRISYNCB]		
PeriodB	<7:0>	Tri level sync parameter Period_a	
D2	Tri Level Sync Parameter (W) [TRISYNCD1]		
Delta1	<6:0>	Bit<6> is sign bit ex. 60h means from blank_level , - 32 every unit	
Reserved	<7>	Reserved	
D3	Tri Level Sync Parameter (W) [TRISYNCD2]		
Delta2	<6:0>	Bit<6> is sign bit ex. 20h means from sync_level, + 32 every unit	
Reserved	<7>	Reserved	
D4	Tri Level Sync Parameter (W) [TRISYNBLANK]		
BlankData	<7:0>	Data of blanking period	
D7	Tri Level Sync Parameter (W) [TRISYNCLEVEL]		
SyncLevel	<7:0>	Sync level value	

XIII. Display Parameter Registers

C2	Tune Display Horizontal Sync Phase (R/W) [DISTUNEHS]		
DisHsDelay	<4:0>	Output horizontal sync delay (Unit: 1 oclk)	
CC	Tune Display Pixel Clock Phase (R/W) [DISTUNESCLK]		
TuneSclk	<2:0>	Phase delay number(8 steps)	
	<4:3>	Phase delay types	
	00	Sclk	

		01	Sclk + delay phase
		10	Inversed Sclk
		11	Inversed Sclk + delay phase
Reserved	<7:5>		Reserved

CA Phase Detection Control Register(R/W) [PHASECTRL]

PhaseEn	<0>		Phase detection Enable
		0	Disable
		1	Enable
PhaseMode	<2:1>		Phase detection precision
		00	8-bit comparison
		01	7-bit comparison
		10	6-bit comparison
		11	5-bit comparison
Reserved	<7:3>		Tie to "00110"

D7 Display Horizontal Total Counter LSB (R) [DISHTOTALCNT]

HTotalCntL	<7:0>		Bit<7:0> of display horizontal total count
------------	-------	--	--

D8 Display Horizontal Total Counter MSB (R) [DISHTOTALCNT]

HTotalCntH	<2:0>		Bit<10:8> of display horizontal total count
Reserved	<7:3>		Reserved

D9 Display Vertical Total Counter LSB (R) [DISVTOTALCNT]

VTotalCntL	<7:0>		Bit<7:0> of display vertical total count
------------	-------	--	--

DA Display Vertical Total Counter MSB (R) [DISVTOTALCNT]

VTotalCntH	<2:0>		Bit<10:8> of display vertical total count
Reserved	<7:3>		Reserved

DB Phase Counter LSB (R) [PHASECNT]

PhaseCntL	<7:0>		Bit<7:0> of phase count value
-----------	-------	--	-------------------------------

DC Phase Counter MSB (R) [PHASECNT]

PhaseCntH	<4:0>	Bit<12:8> of phase count value
Reserved	<7:5>	Reserved

F0 **Enable Brightness/Contrast/Saturation (W) [DISADJEN]**

PanelAdjEn	<0>	Enable brightness/contrast/saturation
Reserved	<7:1>	Reserved

F1 **Brightness Value (W) [BRIGHTNESS]**

Brightness	<7:0>	Brightness value, Default: "80"
------------	-------	---------------------------------

F2 **Contrast Value (W) [CONTRAST]**

Contrast	<7:0>	Contrast value, Default: "40"
----------	-------	-------------------------------

F3 **Saturation Value (W) [SATURATION]**

Saturation	<7:0>	Saturation value, Default: "40"
------------	-------	---------------------------------

10 Electrical Characteristics

10.1 Absolute Maximum Ratings

(Excessive ratings are harmful to the lifetime. Only for user guidelines, not tested.)

Parameter		3.3V Rating	Unit
V _{DD}	Supply Voltage	-0.3 ~ +3.8	V
V _P	Input Pin Voltage	-0.3 ~ +(V _{DD} +0.3)	V
I _O	Output Current	-20 ~ +20	mA
T _{AMB}	Ambient Op. Temperature	0 ~ +85	°C
T _{stg}	Storage Temperature	-40 ~ +125	°C
T _{VSOL}	Vapor Phase Soldering Temperature (15 Sec.)	220	°C

10.2 Recommended Operating Conditions

Parameter		3.3V Rating			Unit
		Min.	Typical	Max.	
V _{DD}	Supply Voltage	+3.0	+3.3	+3.6	V
V _{IH}	High Level Input Voltage	0.7 V _{DD}		V _{DD}	V
V _{IL}	Low Level Input Voltage	0		0.3 V _{DD}	V
T _{AMB}	Ambient Op. Temperature	0		+70	°C

10.3 DC Characteristics

(V_{DD} = 3.3V, V_{SS}=0V. T_{AMB} = 0 to 70°C; Some parameters are guaranteed by design only, not production tested)

Parameter		3.3V Rating			Unit
		Min.	Typical	Max.	

Parameter		3.3V Rating			Unit
		Min.	Typical	Max.	
V_{IH}	Hi-level Input Voltage	$0.7 V_{DD}$	-	V_{DD}	V
V_{IL}	Lo-level Input Voltage	0		$0.3 V_{DD}$	V
V_{OH}	Hi-level Output Voltage	2.4	-	V_{DD}	V
V_{OL}	Lo-level Output Voltage	-	-	+0.4	V
I_{LI}	Input Leakage Current	-5	-	+5	μA
I_{LO}	Output Leakage Current	-5	-	+5	μA

10.4 AC Characteristics

($V_{DD} = 3.3V$, $V_{SS} = 0V$, $T_{AMB} = 0$ to $70^{\circ}C$; Some parameters are guaranteed by design only, not production tested)

11 Timing Diagrams

TBD.

12 Mechanical Drawing- PQFP-208

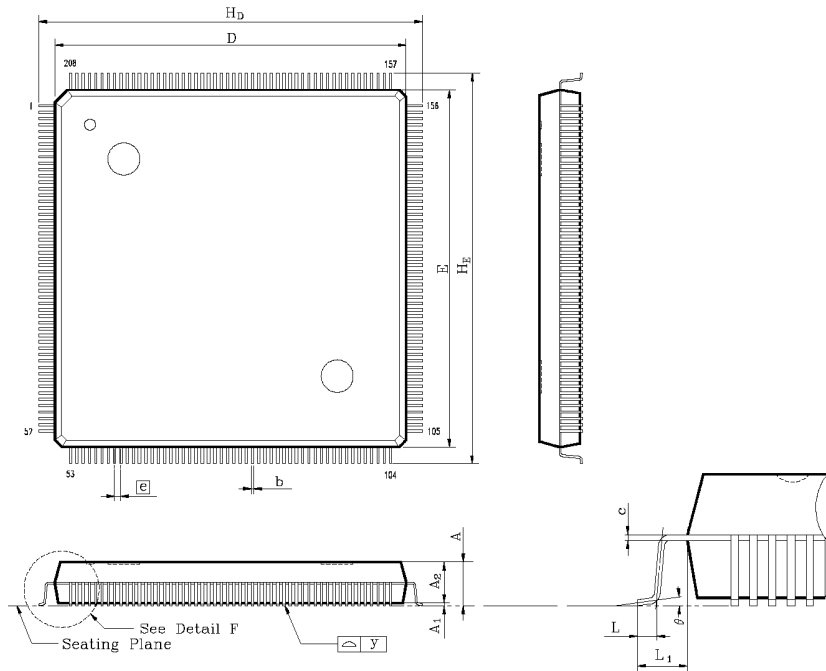

Symbol	Dimension in inch			Dimension in mm		
	Min	Typ	Max	Min	Typ	Max
A	0.136	0.144	0.152	3.45	3.65	3.85
A₁	0.004	0.010	0.036	0.10	0.25	0.91
A₂	0.119	0.128	0.136	3.02	3.24	3.46
b	0.004	0.008	0.012	0.10	0.20	0.30
c	0.002	0.006	0.010	0.04	0.15	0.26
D	1.093	1.102	1.112	27.75	28.00	28.25
E	1.093	1.102	1.112	27.75	28.00	28.25
e	0.012	0.020	0.031	0.30	0.50	0.80
H_b	1.169	1.205	1.240	29.70	30.60	31.50
H_E	1.169	1.205	1.240	29.70	30.60	31.50
L	0.010	0.020	0.030	0.25	0.50	0.75
L₁	0.041	0.051	0.061	1.05	1.30	1.55
y	-	-	0.004	-	-	0.10
θ	0°	-	12°	0°	-	12°

Note:

1. Dimension D & E do not include interlead flash.
2. Dimension b does not include dambar protrusion/intrusion.
3. Controlling dimension: Millimeter
4. General appearance spec. should be based on final visual inspection spec.

TITLE : 208L QFP (28x28 mm**2) FOOTPRINT 2.6mm			
PACKAGE OUTLINE DRAWING			
LEADFRAME MATERIAL:			
APPROVE		DOC. NO.	
		VERSION	1
		PAGE	
CHECK		DWG. NO.	
		DATE	

CONTACT INFORMATION

Averlogic Technologies Corp.
4F, No. 514, Sec. 2, Cheng Kung Rd., Nei-Hu Dist., Taipei, Taiwan
Tel: +886 2-27915050
Fax: +886 2-27912132
E-mail: sales@averlogic.com.tw
URL: <http://www.averlogic.com.tw>

Averlogic Technologies, Inc.
90 Great Oaks Blvd. #204, San Jose, CA 95119, U.S.A.
Tel: 1 408 361-0400
Fax: 1 408 361-0404
E-mail: sales@averlogic.com
URL: <http://www.averlogic.com>