



# ALP239CXX

## Low-Temperature Polysilicon 2.0-inch TFT LCD Module

### Overview

This 2 inch low temperature poly- silicon TFT-LCD module is suitable for digital still camera or for digital video camera.

### Features

- Diagonal 5.1cm (2.0inch) display size.
- $557 \times 234 = 130,338$  dots.
- RGB delta color arrangement.
- Operating temperature (panel) is  $-10$  to  $+60^{\circ}\text{C}$ . Ambient temperature during storage is  $-20$  to  $+70^{\circ}\text{C}$ .
- Slim design, light weight and narrow frame. ( $t=0.7\text{mm}$  glass)
- Up / down and right / left inverse function.
- Built-in level shifter circuit.
- Conform to NTSC, PAL when using recommended IC : LV4135W, LV4137W, (LV4139W : Under development)
- Anti-reflection (AR) coat.
- Panel power consumption is Typ.61mW at NTSC.
- Optical transmittance is approx. 8%.
- Low power consumption by 12V drive.

### Specifications

Item	Specifications	Unit	Remarks
Dot count (H) $\times$ (V)	557 $\times$ 234	dot	
Effective display dimensions (H) $\times$ (V)	40.98 $\times$ 30.77	mm	
Display size (diagonal)	5.1 (2.0inch)	cm	
Dot pitch (H) $\times$ (V)	0.0735 $\times$ 0.1315	mm	
Color arrangement	RGB Delta	-	
External Dimensions (W) $\times$ (H) $\times$ (D)	TYP 47.9 $\times$ 39.9 $\times$ 2.1	mm	Note1
Weight	Approx. 8	g	

\*Note1: Excluding flexible cable and protrusions.

- Any and all SANYO products described or contained herein do not have specifications that can handle applications that require extremely high levels of reliability, such as life-support systems, aircraft's control systems, or other applications whose failure can be reasonably expected to result in serious physical and/or material damage. Consult with your SANYO representative nearest you before using any SANYO products described or contained herein in such applications.
- SANYO assumes no responsibility for equipment failures that result from using products at values that exceed, even momentarily, rated values (such as maximum ratings, operating condition ranges, or other parameters) listed in products specifications of any and all SANYO products described or contained herein.

## ALP239CXX

### Absolute Maximum Ratings at VSS=0V

Item	Symbol	Ratings	Unit
H driver power supply voltage	HVDD	-1.0 to +14	V
V driver power supply voltage	VVDD	-1.0 to +14	V
Common electrode voltage	VCOM	-1.0 to +14	V
Driving direction signal voltage	CSH, CSV	-1.0 to +14	V
H driver input voltage	STH, XSTH, CKH1, CKH2	-1.0 to +14	V
V driver / precharge data input voltage	STV, XSTV, CKV1, CKV2, ENB, XENB, PCG, XPCG	-1.0 to +14	V
Video / precharge data input voltage	VG, VR, VB, VPCD	-1.0 to +13	V
Operating temperature (panel)	Topr	-10 to +60	°C
Storage temperature	Tstg	-20 to +70	°C

### Operating Conditions

#### Power supply voltage

HVDD LV4135W LV4137W : 12.0V±0.3V

VVDD LV4135W LV4137W : 12.0V±0.3V

VSS LV4135W LV4137W : 0V

Item	Symbol	MIN	TYP	MAX	Unit	
H driver input voltage	Low	VHIL	-0.3	0.0	0.3	V
	High	VHIH	2.5	3.0	4.0	V
V driver input voltage	Low	VVIL	-0.3	0.0	0.3	V
	High	VVIH	2.5	3.0	4.0	V
CSV, CSH	Low	VSIL	-0.3	0.0	0.3	V
	High	VSIH	11.5	VDD	VDD	V
Video signal center voltage	LV4135W, LV4137W	VVC	5.0	5.2	5.4	V
Video signal input voltage range *1	VG, VR, VB	VVC-3.5	-	VVC+3.5	V	
Common electrode voltage*2	VCOM	(VVC-0.2)-0.2	(VVC-0.2)	(VVC-0.2)+0.2	V	
Precharge data signal *1	VPCD	VVC±1.5	VVC±2.0	VVC±2.5	V	

\*1 Video signal and precharge data signal shall be input symmetrically around VVC.

\*2 Set common electrode voltage to the optimum voltage.

### Optical Specifications

Item	Symbol	Condition	MIN	TYP	MAX	Unit
Contrast ratio	CR	25°C	-	100	-	-
Viewing angle range	θT	CR ≥ 10	-	15	-	deg
	θB			35		
	θL			45		
	θR			45		

## Pin Function

Pin No	Symbol	Function
1	NC	Leave this pin open
2	COM	Common electrode voltage
3	CKV1	V clock 1
4	CKV2	V clock 2
5	VVDD	VDD for V drive
6	STV	V start signal
7	XSTV	Inverted signal of STV
8	CSV	Up / down inverse control signal (H : Normal scan, L : Reverse scan)
9	ENB	Enable signal
10	XENB	Inverted signal of ENB
11	PCD	Precharge data signal
12	B	Video signal (B)
13	R	Video signal (R)
14	G	Video signal (G)
15	VSS	VSS for V and H drive
16	XPCG	Inverted signal of PCG
17	PCG	Precharge gate signal
18	CSH	Right / left inverse control signal (H : Normal scan, L : Reverse scan)
19	XSTH	Inverted signal of STH
20	STH	H start signal
21	CKH2	H clock 2
22	CKH1	H clock 1
23	HVDD	VDD for H drive
24	NC	Leave this pin open

Block Diagram

Front View

→ Normal Scan

← Reverse Scan

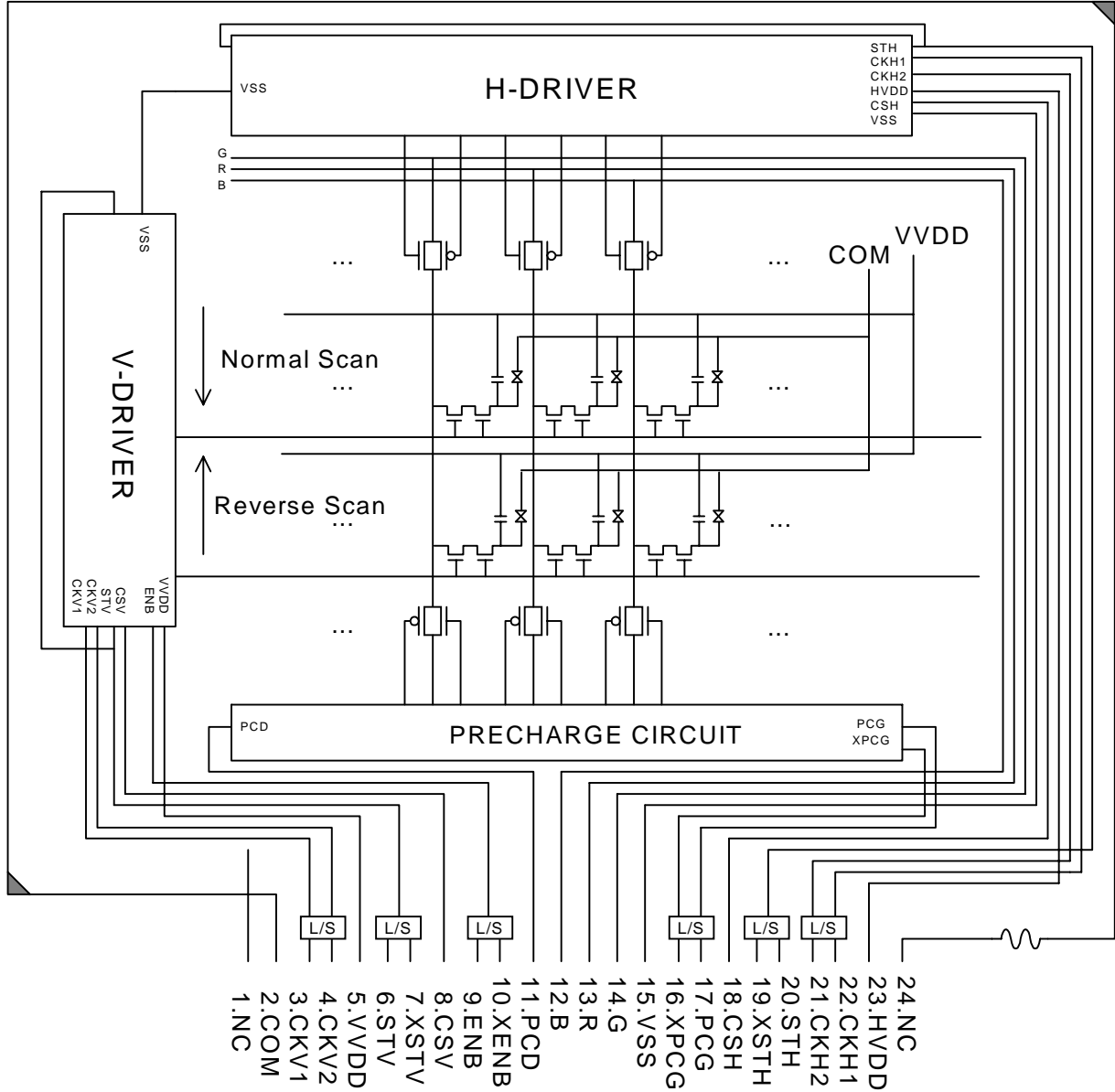

System Configuration

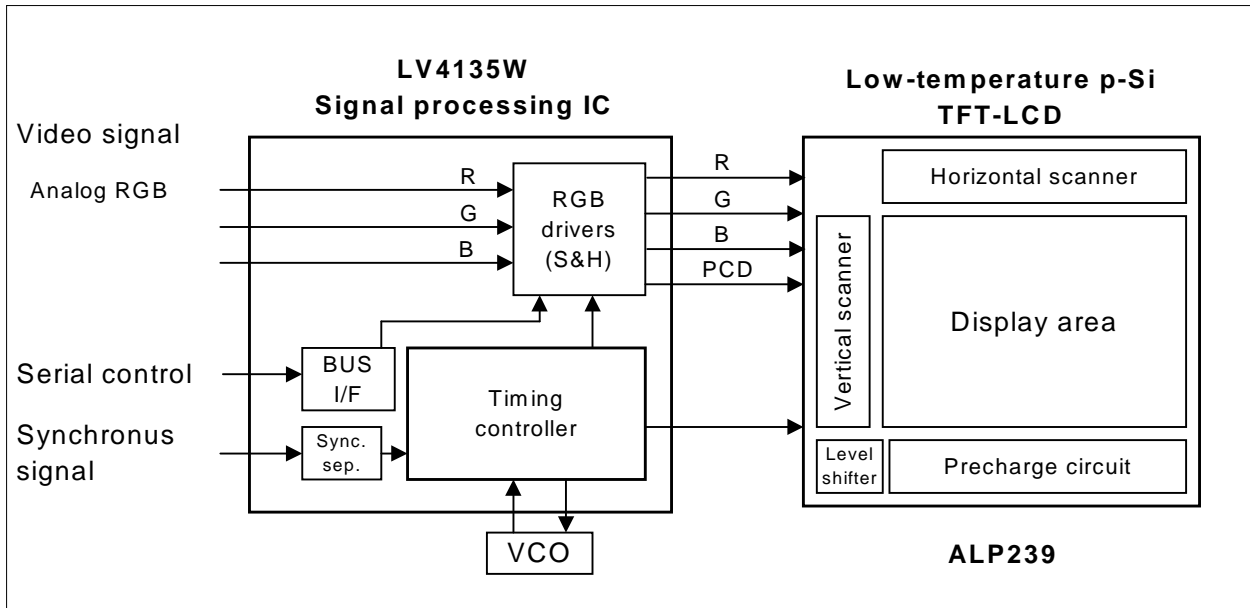
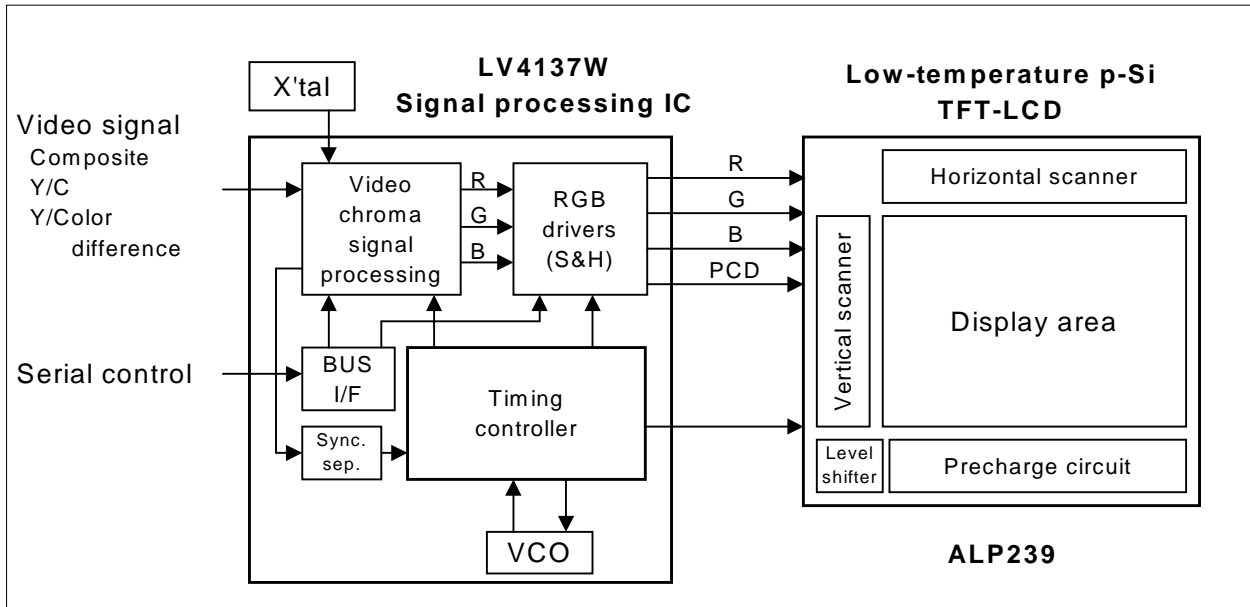

## System Configuration

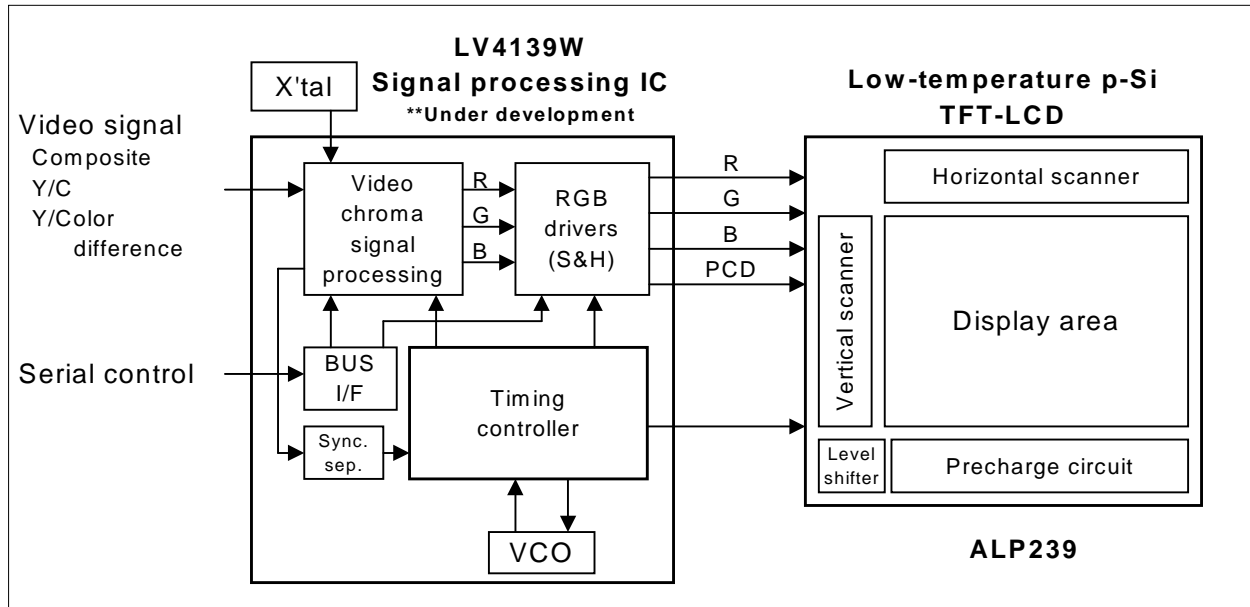

Package Dimension

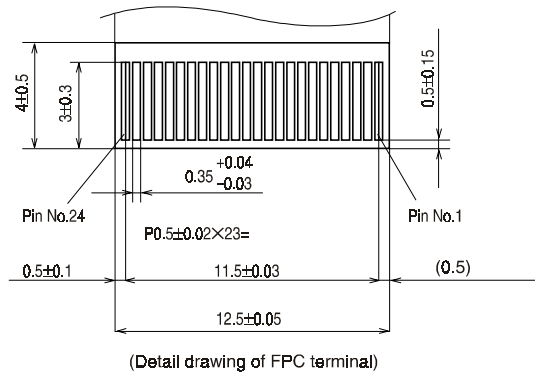
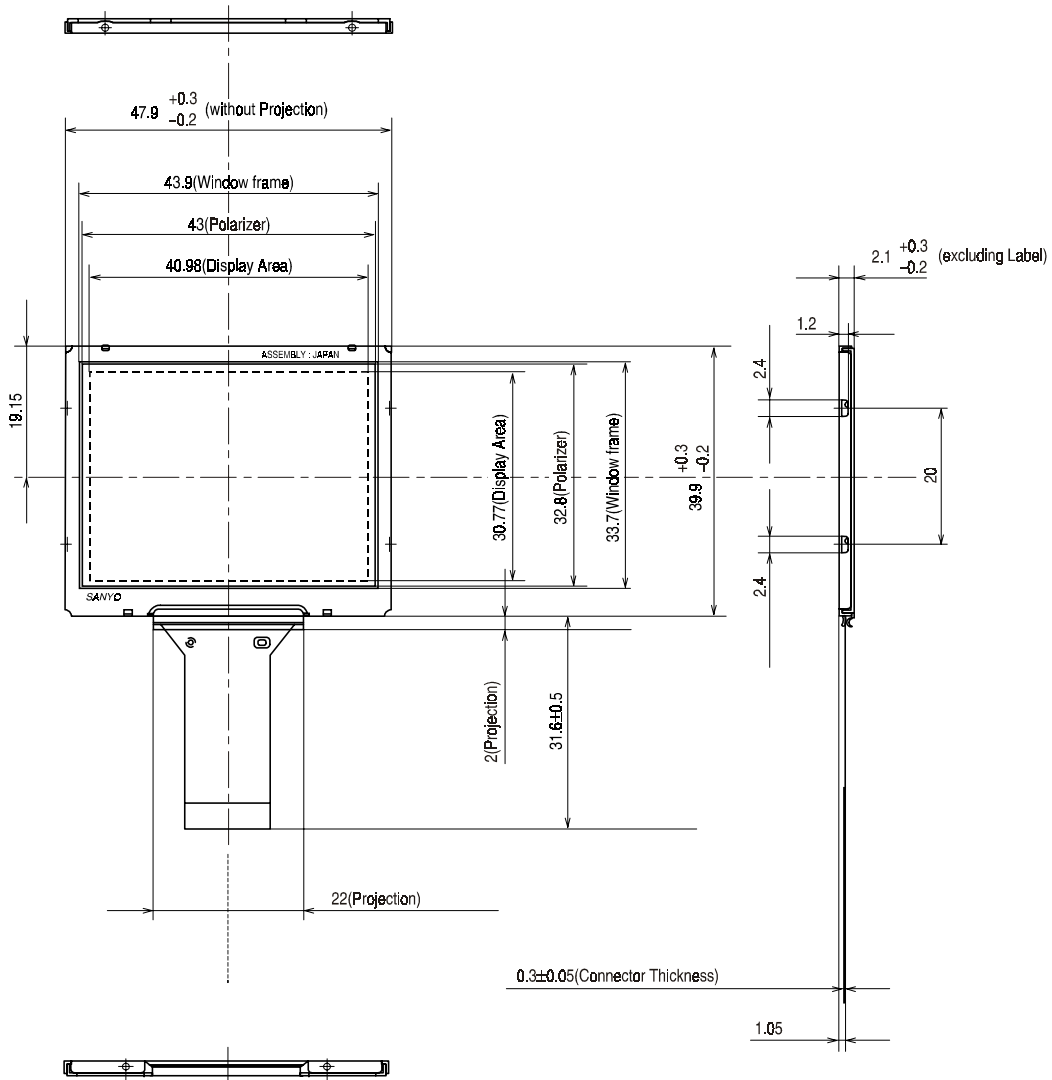

- Specifications of any and all SANYO products described or contained herein stipulate the performance, characteristics, and functions of the described products in the independent state, and are not guarantees of the performance, characteristics, and functions of the described products as mounted in the customer's products or equipment. To verify symptoms and states that cannot be evaluated in an independent device, the customer should always evaluate and test devices mounted in the customer's products or equipment.
- SANYO Electric Co., Ltd. strives to supply high-quality high-reliability products. However, any and all semiconductor products fail with some probability. It is possible that these probabilistic failures could give rise to accidents or events that could endanger human lives, that could give rise to smoke or fire, or that could cause damage to other property. When designing equipment, adopt safety measures so that these kinds of accidents or events cannot occur. Such measures include but are not limited to protective circuits and error prevention circuits for safe design, redundant design, and structural design.
- In the event that any or all SANYO products (including technical data, services) described or contained herein are controlled under any of applicable local export control laws and regulations, such products must not be exported without obtaining the export license from the authorities concerned in accordance with the above law.
- No part of this publication may be reproduced or transmitted in any form or by any means, electronic or mechanical, including photocopying and recording, or any information storage or retrieval system, or otherwise, without the prior written permission of SANYO Electric Co., Ltd.
- Any and all information described or contained herein are subject to change without notice due to product/technology improvement, etc. When designing equipment, refer to the "Delivery Specification" for the SANYO product that you intend to use.
- Information (including circuit diagrams and circuit parameters) herein is for example only; it is not guaranteed for volume production. SANYO believes information herein is accurate and reliable, but no guarantees are made or implied regarding its use or any infringements of intellectual property rights or other rights of third parties.

This catalog provides information as of January, 2001. Specifications and information herein are subject to change without notice.