

# Quad BTL Power Driver AM5810

The AM5810 is a 4-channel BTL driver - 2 channels are able to use for stepping motor, and 1 channel is for reversible driver - designed to be used with ordinary electronic equipment (such as audio-visual equipment, office automation equipment, communications devices, electrical appliances, and electronic toys).

● **Applications**

CD players

● **Features**

- |   |   |
|---|---|
| <ul style="list-style-type: none"> <li>1) A power saving mode is enabled by power-saver terminal.</li> <li>2) Small surface mounting power package (HSOP-28)</li> <li>3) Separating Vcc into Pre and Pow, can make better power efficiency</li> <li>4) Thermal-shut-down circuit built in</li> <li>5) Wide dynamic range &lt;4.0V (Typ.) at PreVcc=12V, PowVcc=5V &gt;</li> </ul> | <ul style="list-style-type: none"> <li>6) BTL driver: Input pins consist of (+) and (-), therefore various input types are available such as differential input.</li> <li>7) Loading driver:               <ul style="list-style-type: none"> <li>a. The output voltage is adjustable by output voltage control terminal. (Only “H” side voltage)</li> <li>b. Brake circuit built in</li> <li>c. Circuit protection diode built in</li> </ul> </li> </ul> |
|---|---|

● **Absolute Maximum Ratings**

Parameter	Symbol	Limits	Unit
Supply voltage	PREVCC, POWVCC	13.5	V
Power dissipation	Pd	1.7*	W
Operating temperature	Topr	-40 ~ +85	°C
Storage temperature	Tstg	-55 ~ +150	°C

\*On less than 3% (percentage occupied by copper foil), 70 x 70mm<sup>2</sup>, t = 1.6mm, glass epoxy mounting. Reduce power by 13.5mW for each degree above 25°C.

● **Guaranteed Operating Ranges**

PREVCC	4.3 ~ 13.2V
POWVCC	4.3 ~ PREVCC

● **Block Diagram**

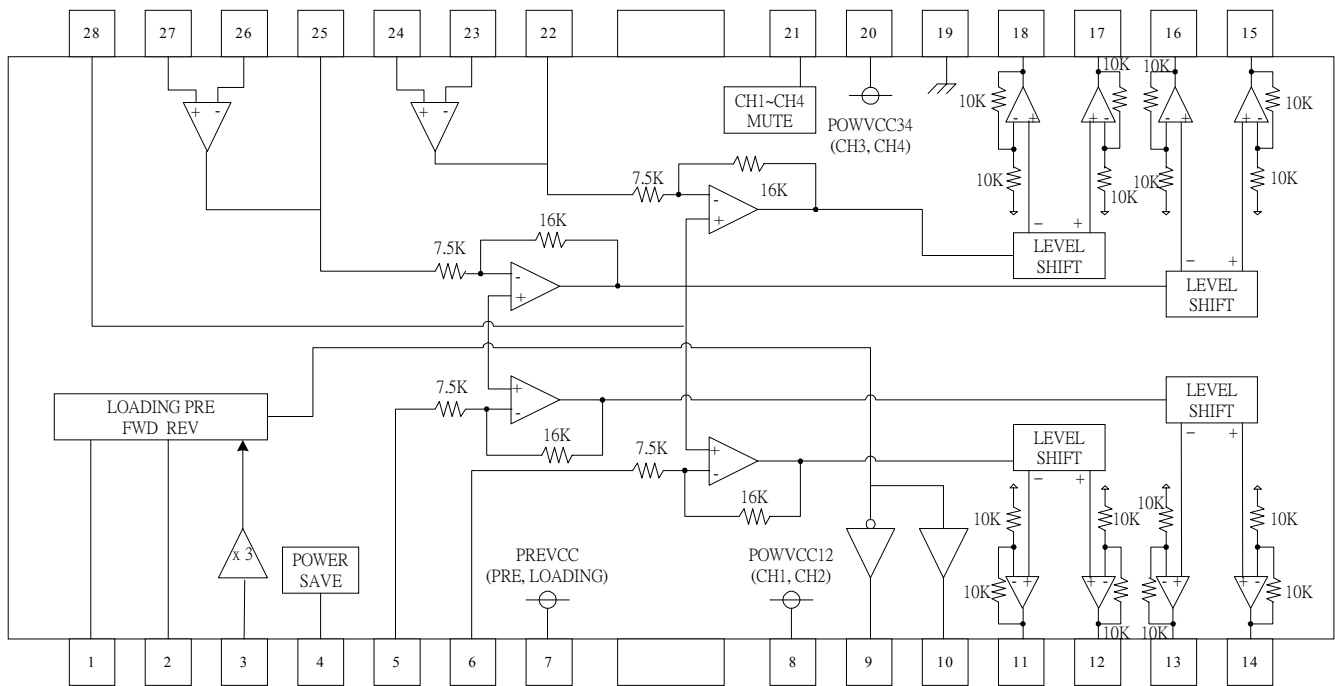

● Pin configuration

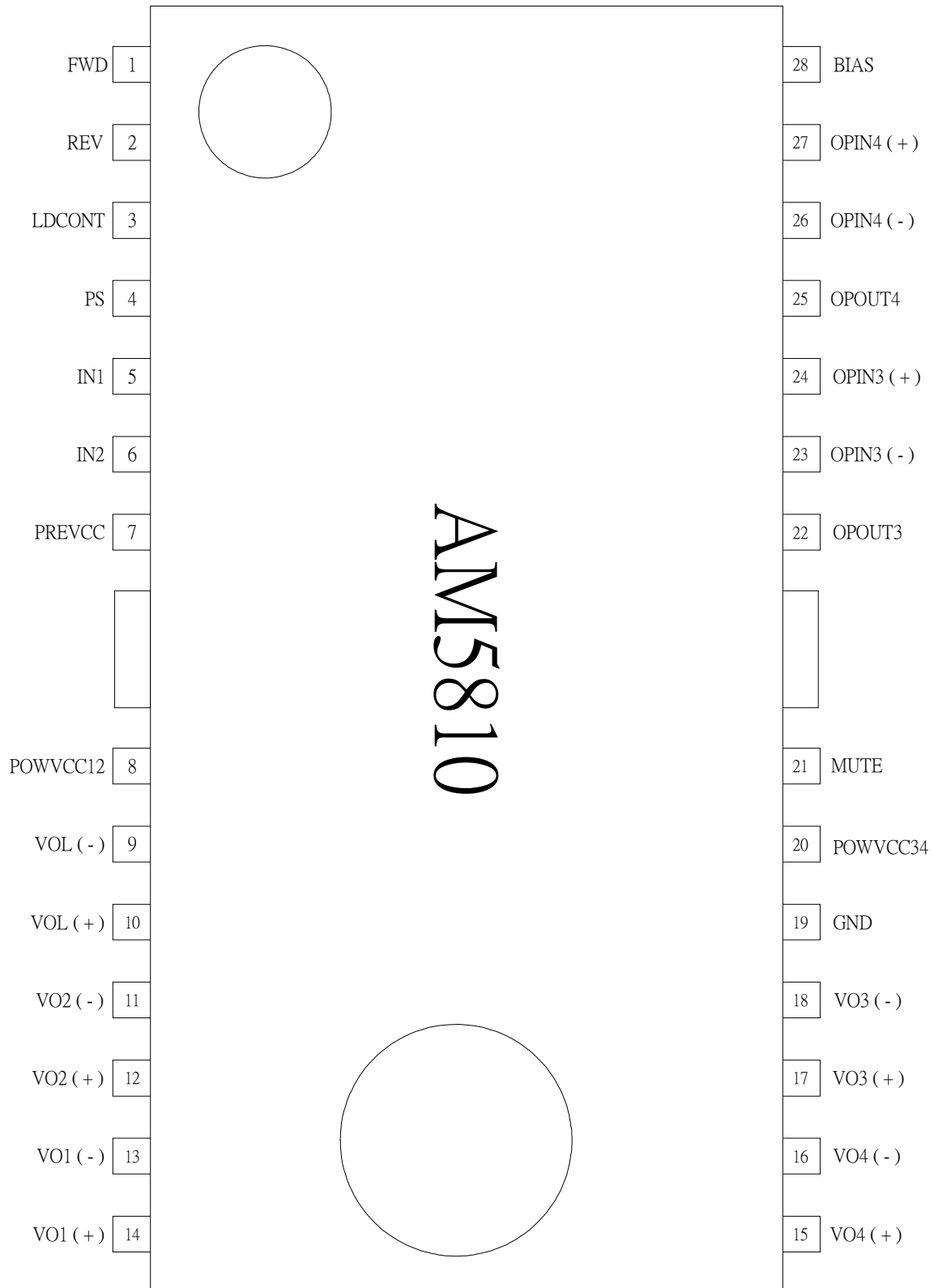

● **Pin Description**

PIN No	Pin Name	Description
1	FWD	Input for loading forward
2	REV	Input for loading reverse
3	LDCONT	Output control terminal for loading
4	PS	Control terminal for power saving mode
5	IN1	Input 1 of CH1
6	IN2	Input 2 of CH2
7	PREVCC	Pre and loading unit power supply input terminal
8	POWVCC12	Power unit power supply input terminal (CH1, CH2)
9	VOL (-)	Inverted output of loading
10	VOL (+)	Not inverted output of loading
11	VO2 (-)	Inverted output of CH2
12	VO2 (+)	Not inverted output of CH2
13	VO1 (-)	Inverted output of CH1
14	VO1 (+)	Not inverted output of CH1
15	VO4 (+)	Not inverted output of CH4
16	VO4 (-)	Inverted output of CH4
17	VO3 (+)	Not inverted output of CH3
18	VO3 (-)	Inverted output of CH3
19	GND	Substrate ground
20	POWVCC34	Power unit power supply input terminal (CH3, CH4)
21	MUTE	Input for mute control
22	OPOUT3	Output of CH3 OP-ANP
23	OPIN3 (-)	Inverting input of CH3 OP-ANP
24	OPIN3 (+)	Not inverting input of CH3 OP-ANP
25	OPOUT4	Output of CH4 OP-ANP
26	OPIN4 (-)	Inverting input of CH4 OP-ANP
27	OPIN4 (+)	Not inverting input of CH4 OP-ANP
28	BIAS	Input of Bias-Amplifier

## ● Application

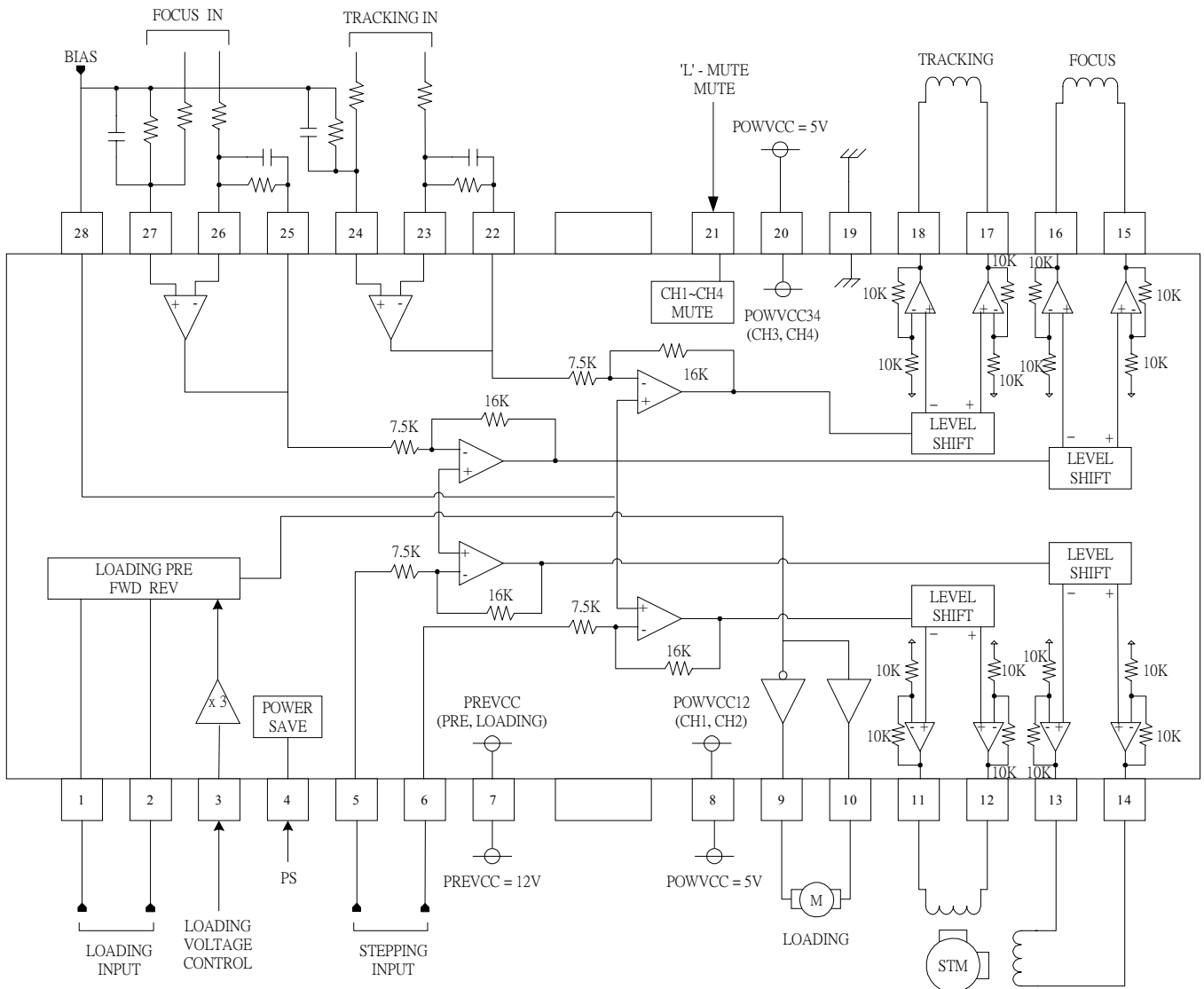

- **Electrical Characteristics ( Unless otherwise specified, Ta = 25°C, PREVCC = 12V, POWVCC12/34 = 5V, BIAS = 1.65V, PS = 2V, RL = 8Ω )**

Parameter	Symbol	Conditions	Limit			Unit
			Min	Typ	Max	
Quiescent Current	ICC	RL = ∞	-	22.9	34	mA
Power save on current	IPS	PS = “L”	-	1.65	2.8	mA
Power save on voltage	VPSON		-	-	0.5	V
Power save off voltage	VPSOFF		2.0	-	-	V

**< BTL Driver >**

Output offset voltage	VOO		-50	0	50	mV
Max. output voltage	VOM		3.6	4.0	-	V
Closed loop voltage gain	GVC		17.2	19.0	20.8	dB
Mute on voltage	VMTON		-	-	0.5	V
Mute off voltage	VMTOFF		1.5	-	-	V
Input current for mute pin	IMUTE	VMUTE = 5V	-	180	270	μA
Input current for Bias pin	IBIAS	BVIAS = 2.5V	-	75	120	μA

**< OP-ANP (CH3,4) >**

Common mode input voltage range	VICM		0.5	-	10.0	V
Input offset voltage	VOFOP		-6	0	6	mV
Input bias current	IBOP		-	-	300	nA
High level output voltage	VOHOP	BIAS = 6V	11.5	-	-	V
Low level output voltage	VOLOP	BIAS = 6V	-	-	0.5	V
Output sink current	ISIN		1	-	-	mA
Output source current	ISOU		1	-	-	mA
Slew rate	SROP	Input pulse 100KHz, 2Vp-p	-	1	-	V/μs

**< Loading Driver >**

Output saturation voltage 1	VSAT1	Upper + Lower saturation, IL = 200mA	0.7	1.1	1.5	V
Output saturation voltage between F&R	ΔVSAT1	Output saturation voltage 1 between FWD and REV	-	-	0.1	V
Output saturation voltage 2	VSAT2	Upper + Lower saturation, IL = 500mA	1.0	1.55	2.2	V
Output adjustable gain on “H” side voltage	GVH	“H” side output for input (LDCNT)	7.4	9.2	11	dB

**< Loading driver input logic >**

Input high level voltage	VIHLD		1.5	-	VCC	V
Input low level voltage	VILLD		-0.3	-	0.5	V
Input high level current	IIHLD	VFWD = VREV = 5V	-	180	270	μA

※This product is not designed for protection against radioactive rays.

● Equivalent Circuit Of Terminals

Input of Bias Amplifier	Output of BTL Driver
	<p>Noninverted output of driver 12,14,15,17 PIN</p> <p>Inverted output of driver 11,13,16,18 PIN</p>
Input of OP-AMP	Input for Mute - Loading Driver
Output of OP-AMP & Input of BLT Driver	Output of Loading Driver
Control Terminal for Power Saving Mode	Output Control Terminal for Loading