



# 87C196CA 18 MHz Advanced 16-Bit CHMOS Microcontroller

*Automotive*

---

**Datasheet**

## Product Features

- -40°C to +125°C Ambient
- High Performance CHMOS 16-Bit CPU
- 32 Kbytes of On-Chip EPROM
- 1.0 Kbytes of On-Chip Register RAM
- 256 Bytes of Additional RAM (Code RAM)
- Register-Register Architecture
- SixChannel/10-Bit A/D with Sample/Hold
- Up to 37 Prioritized Interrupt Sources
- 38 I/O Ports
- Full Duplex Serial I/O Port
- Dedicated Baud Rate Generator
- Interprocessor Communication Slave Port
- High Speed Peripheral Transaction Server (PTS)
- Two 16-Bit Software Timers
- Six High Speed Capture/Compare (EPA)
- Full Duplex Synchronous Serial I/O Port (SSIO)
- Two Flexible 16-Bit Timer/Counters
- Quadrature Counting Inputs
- Flexible 8-/16-Bit External Bus
- Programmable Bus (HLD/HLDA)
- 1.75  $\mu$ s 16 x 16 Multiply
- 3  $\mu$ s 32/16 Divide
- 68-Pin PLCC Package
- Supports CAN (Controller Area Network) Specification 2.0



Information in this document is provided in connection with Intel products. No license, express or implied, by estoppel or otherwise, to any intellectual property rights is granted by this document. Except as provided in Intel's Terms and Conditions of Sale for such products, Intel assumes no liability whatsoever, and Intel disclaims any express or implied warranty, relating to sale and/or use of Intel products including liability or warranties relating to fitness for a particular purpose, merchantability, or infringement of any patent, copyright or other intellectual property right. Intel products are not intended for use in medical, life saving, or life sustaining applications.

Intel may make changes to specifications and product descriptions at any time, without notice.

Designers must not rely on the absence or characteristics of any features or instructions marked "reserved" or "undefined." Intel reserves these for future definition and shall have no responsibility whatsoever for conflicts or incompatibilities arising from future changes to them.

The 87C196CA microcontroller may contain design defects or errors known as errata which may cause the product to deviate from published specifications. Current characterized errata are available on request.

Contact your local Intel sales office or your distributor to obtain the latest specifications and before placing your product order.

Copies of documents which have an ordering number and are referenced in this document, or other Intel literature may be obtained by calling 1-800-548-4725 or by visiting Intel's website at <http://www.intel.com>.

Copyright © Intel Corporation, 1998

\*Third-party brands and names are the property of their respective owners.

# Contents

---

<b>1.0</b>	<b>Introduction</b> .....	<b>1</b>
<b>2.0</b>	<b>Architecture</b> .....	<b>2</b>
2.1	CPU Features .....	2
2.2	Peripheral Features .....	2
2.3	New Instructions .....	2
2.3.1	XCH/XCHB .....	2
2.3.2	BMOVi .....	2
2.3.3	TIJMP .....	3
2.3.4	EPTS/DPTS .....	3
2.4	SFR Operation .....	3
<b>3.0</b>	<b>Packaging Information</b> .....	<b>5</b>
<b>4.0</b>	<b>Electrical Characteristics</b> .....	<b>8</b>
4.1	Absolute Maximum Ratings .....	8
4.2	Operating Conditions .....	8
4.3	DC Characteristics .....	9
4.4	AC Characteristics .....	11
4.4.1	Explanation of AC Symbols .....	16
4.4.2	EPROM Specifications .....	16
4.4.3	A to D Converter Specifications .....	18
4.4.4	AC Characteristics—Slave Port .....	20
4.4.5	AC Characteristics—Serial Port— Shift Register Mode .....	22
4.4.6	Waveform—Serial Port—Shift Register Mode 0 .....	22
<b>5.0</b>	<b>Design Considerations</b> .....	<b>23</b>
5.1	87C196CA Design Considerations .....	23
<b>6.0</b>	<b>Revision History</b> .....	<b>25</b>

## Figures

1	Block Diagram .....	3
2	87C196CA Nomenclature .....	4
3	87C196CA 68-Pin PLCC Package Diagram .....	5
4	87C196CA $I_{CC}$ vs. Frequency .....	10
5	System Bus Timing .....	13
6	READY Timing .....	14
7	External Clock Drive Waveforms .....	14
8	AC Testing Input, Output Waveforms .....	15
9	Float Waveforms .....	15
10	Slave Programming Mode Data Program Mode with Single Program Pulse .....	17
11	Slave Programming Mode in Word Dump or Data Verify Mode with Auto Increment .....	17
12	Slave Programming Mode Timing in Data Program Mode with Repeated PROG Pulse and Auto Increment .....	18
13	Slave Port Waveform (SLPL = 0) .....	20
14	Slave Port Waveform (SLPL = 1) .....	21
15	Serial Port Waveform—Shift Register Mode .....	22

## Tables

1	87C196Kx and Jx Features Summary .....	1
2	Pin Descriptions .....	6
3	Absolute Maximum Ratings .....	8
4	Operating Conditions .....	8
5	DC Characteristics .....	9
6	AC Characteristics .....	11
7	External Clock Drive .....	14
8	Thermal Characteristics .....	15
9	AC EPROM Programming Characteristics .....	16
10	DC EPROM Programming Characteristics .....	17
11	A/D Operating Conditions .....	18
12	A/D Operating Parameter Values .....	19
13	Slave Port Timing—(SLPL = 0) .....	20
14	Slave Port Timing—(SLPL = 1) .....	21
15	Serial Port Timing—Shift Register Mode .....	22

## 1.0 Introduction

The MCS 96 microcontroller family members are all high performance microcontrollers with a 16-bit CPU.

The 87C196CA family members are composed of the high-speed (18 MHz) core as well as the following peripherals:

- 32 Kbytes of Programmable EPROM
- 1.0 Kbytes of register RAM and 512 bytes of code RAM (16-bit addressing modes) with the ability to execute from this RAM space
- Six–10-Bit/  $\pm 3$  LSB analog to digital converter with programmable S/H times with conversion times  $< 5 \mu\text{s}$  at 16 MHz
- An asynchronous/synchronous serial I/O port (8096 compatible) with a dedicated 16-bit baud rate generator
- Interprocessor communication slave port
- Synchronous serial I/O port with full duplex master/slave transceivers
- A flexible timer/counter structure with prescaler, cascading, and quadrature capabilities
- Six modularized multiplexed high speed I/O for capture and compare (called Event Processor Array) with 250 ns resolution and double buffered inputs
- A sophisticated prioritized interrupt structure with programmable Peripheral Transaction Server (PTS). The PTS has several channel modes, including single/burst block transfers from any memory location to any memory location, a PWM and PWM toggle mode to be used in conjunction with the EPA, and an A/D scan mode.
- Serial communications protocol CAN 2.0 with 15 message objects of 8 bytes data length

The 87C196CA device is a member of the fourth generation of MCS<sup>®</sup> 96 microcontroller products implemented on Intel’s advanced 1 micron process technology. This product is based on the 80C196KB device with improvements for automotive applications. The instruction set is a true super set of 80C196KB.

The 87C196CA device is a memory scalar of the 87C196KR in a 68-pin package with 32 Kbytes of on-chip EPROM, 1.0 Kbytes of register RAM, and 256 bytes of code RAM. In addition, the 87C196CA contains an extra peripheral for serial communications protocol CAN 2.0.

Table 1 summarizes the features of the 87C196CA device.

**Table 1. 87C196Kx and Jx Features Summary**

Device	Pins/Package	EPROM	Reg RAM	Code RAM	I/O	EPA	SIO	SSIO	A/D
87C196CA	68-Pin PLCC	32 K	1.0 K	256	38	6	Y	Y	6

## 2.0 Architecture

---

The 87C196CA is a member of the MCS 96 microcontroller family, has the same architecture and use the same instruction set as the 80C196KB/KC. Many new features have been added including:

### 2.1 CPU Features

- Powerdown and Idle Modes
- 18 MHz Operating Frequency
- A High Performance Peripheral Transaction Server (PTS)
- Up to 37 Interrupt Vectors
- 256 Bytes of Code RAM
- 1.0 Kbytes of Register RAM
- “Windowing” Allows 8-Bit Addressing to Some 16-Bit Addresses
- 1.75  $\mu$ s 16 x 16 Multiply
- 3  $\mu$ s 32/16 Divide
- Oscillator Fail Detect

### 2.2 Peripheral Features

- Programmable A/D Conversion and S/H Times
- Six Capture/Compare I/O with 2 Flexible Timers
- Synchronous Serial I/O Port for Full Duplex Serial I/O
- Total Utilization of ALL Available Pins (I/O Mux'd with Control)
- Two 16-Bit Timers with Prescale, Cascading and Quadrature Counting Capabilities
- Up to 12 Externally Triggered Interrupts

### 2.3 New Instructions

#### 2.3.1 XCH/XCHB

Exchange the contents of two locations, either Word or Byte is supported.

#### 2.3.2 BMOVi

Interruptable Block Move Instruction, allows the user to be interrupted during long executing Block Moves.

### 2.3.3 TIJMP

Table Indirect JUMP. This instruction incorporates a way to do complex CASE level branches through one instruction. An example of such code savings: several interrupt sources and only one interrupt vector. The TIJMP instruction will sort through the sources and branch to the appropriate sub-code level in one instruction. This instruction was added especially for the EPA structure, but has other code saving advantages.

### 2.3.4 EPTS/DPTS

Enable and Disable PTS Interrupts (Works like EI and DI).

## 2.4 SFR Operation

The 87C196CA device contains 512 bytes of SFR registers to support the wide range of on-chip peripherals. The memory space 1F00-1FFFh has the ability to be addressed as direct 8-bit addresses through the “windowing” technique. The memory space 1E00-1EFFh is reserved for CAN functions.

Figure 1. Block Diagram

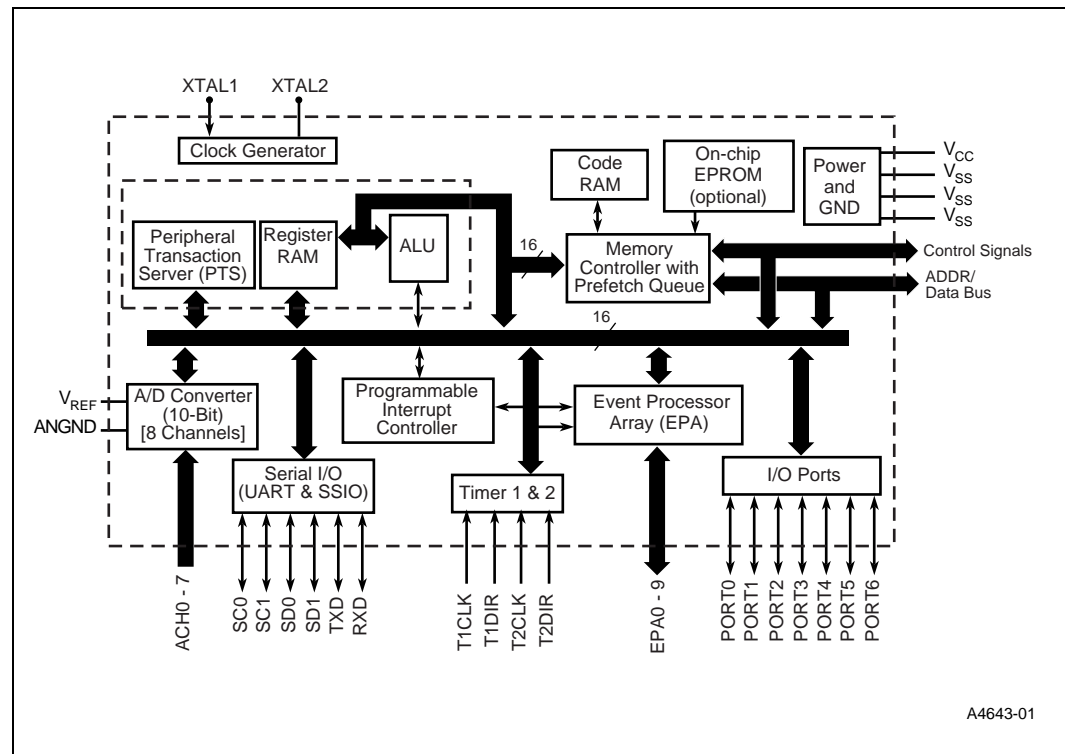
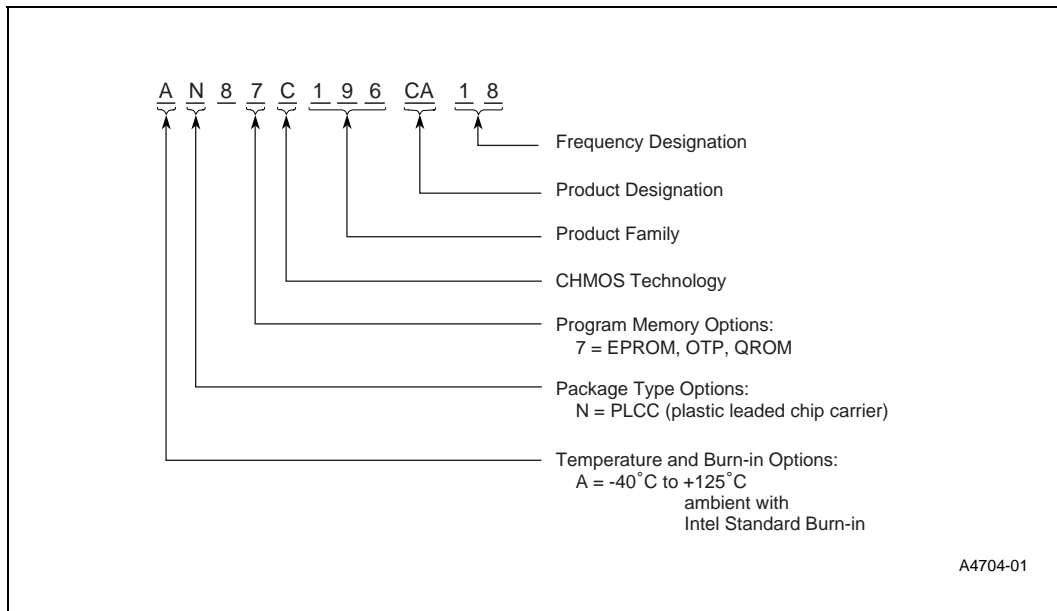

Figure 2. 87C196CA Nomenclature





### 3.0 Packaging Information

Figure 3. 87C196CA 68-Pin PLCC Package Diagram

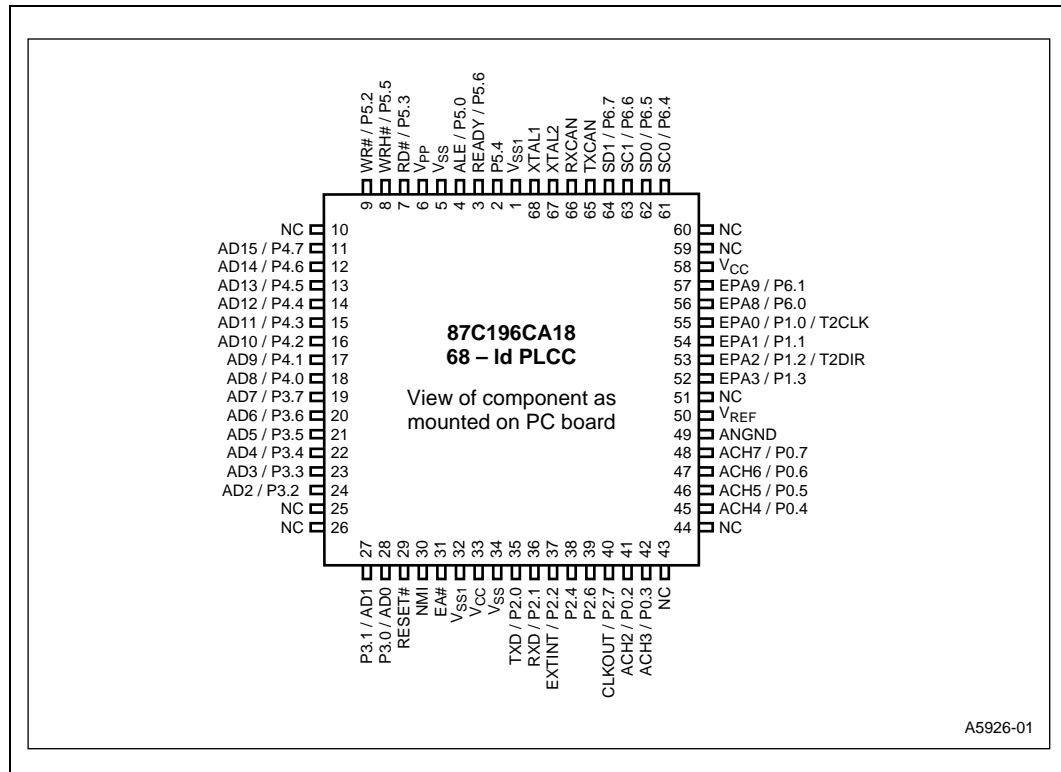

**Table 2. Pin Descriptions (Sheet 1 of 2)**

Symbol	Name and Function
V <sub>CC</sub>	Main supply voltage (+5 V).
V <sub>SS</sub>	Digital circuit ground (0 V). There are three V <sub>SS</sub> pins, all of which MUST be connected to a single ground plane.
V <sub>REF</sub>	Reference for the A/D converter (+5 V). V <sub>REF</sub> is also the supply voltage to the analog portion of the A/D converter and the logic used to read Port 0. Must be connected for A/D and Port 0 to function.
V <sub>PP</sub>	Programming voltage for the EPROM parts. It should be +12.5 V for programming. It is also the timing pin for the return from powerdown circuit. Connect this pin with a 1 μF capacitor to V <sub>SS</sub> and a 1 MΩ resistor to V <sub>CC</sub> . If this function is not used, V <sub>PP</sub> may be tied to V <sub>CC</sub> .
ANGND	Reference ground for the A/D converter. Must be held at nominally the same potential as V <sub>SS</sub> .
XTAL1	Input of the oscillator inverter and the internal clock generator.
XTAL2	Output of the oscillator inverter.
P2.7/CLKOUT	Output of the internal clock generator. The frequency is ½ the oscillator frequency. It has a 50% duty cycle. Also LSIO pin when not used as CLKOUT.
RESET#	Reset input to the chip. Input low for at least 16 state times will reset the chip. The subsequent low to high transition resynchronizes CLKOUT and commences a 10-state time sequence in which the PSW is cleared, bytes are read from 2018H and 201AH loading the CCBs, and a jump to location 2080H is executed. Input high for normal operation. RESET# has an internal pullup.
NMI	A positive transition causes a non-maskable interrupt vector through memory location 203EH.
EA#	Input for memory select (External Access). EA# equal to a high causes memory accesses within the [EP]ROM address space to be directed to on-chip EPROM/ROM. EA# equal to a low causes accesses to these locations to be directed to off-chip memory. EA# = +12.5 V causes execution to begin in the Programming Mode. EA# latched at reset.
P5.0/ALE/ADV#	Address Latch Enable or Address Valid output, as selected by CCR. Both pin options provide a latch to demultiplex the address from the address/data bus. When the pin is ADV#, it goes inactive (high) at the end of the bus cycle. ADV# can be used as a chip select for external memory. ALE/ADV# is active only during external memory accesses. Also LSIO when not used as ALE.
P5.3/RD#	Read signal output to external memory. RD# is active only during external memory reads. LSIO when not used as RD#.
P5.2/WR#/WRL#	Write and Write Low output to external memory, as selected by the CCR, WR# will go low for every external write, while WRL# will go low only for external writes where an even byte is being written. WR#/WRL# is active during external memory writes. Also an LSIO pin when not used as WR#/WRL#.
P5.5/BHE#/WRH#	Byte High Enable or Write High output, as selected by the CCR. BHE# = 0 selects the bank of memory that is connected to the high byte of the data bus. A0 = 0 selects that bank of memory that is connected to the low byte. Thus accesses to a 16-bit wide memory can be to the low byte only (A0 = 0, BHE# = 1), to the high byte only (A0 = 1, BHE# = 0) or both bytes (A0 = 0, BHE# = 0). If the WRH# function is selected, the pin will go low if the bus cycle is writing to an odd memory location. BHE#/WRH# is only valid during 16-bit external memory write cycles. Also an LSIO pin when not BHE#/WRH#.

Table 2. Pin Descriptions (Sheet 2 of 2)

Symbol	Name and Function
P5.6/READY	Ready input to lengthen external memory cycles, for interfacing with slow or dynamic memory, or for bus sharing. If the pin is high, CPU operation continues in a normal manner. If the pin is low prior to the falling edge of CLKOUT, the memory controller goes into a wait state mode until the next positive transition in CLKOUT occurs with READY high. When external memory is not used, READY has no effect. The max number of wait states inserted into the bus cycle is controlled by the CCR/CCR1. Also an LSIO pin when READY is not selected.
P5.4/SLPINT	Dual functional I/O pin. As a bidirectional port pin (LSIO) or as a system function. The system function is a Slave Port Interrupt Output Pin.
P6.2/T1CLK	Dual function I/O pin. Primary function is that of a bidirectional I/O pin (LSIO); however it may also be used as a TIMER1 Clock input. The TIMER1 will increment or decrement on both positive and negative edges of this pin.
P6.3/T1DIR	Dual function I/O pin. Primary function is that of a bidirectional I/O pin (LSIO); however it may also be used as a TIMER1 Direction input. The TIMER1 will increment when this pin is high and decrements when this pin is low.
PORT1/EPA0–3 P6.0–6.1/EPA8–9	Dual function I/O port pins. Primary function is that of bidirectional I/O (LSIO). System function is that of High Speed capture and compare. EPA0 and EPA2 have yet another function of T2CLK and T2DIR of the TIMER2 timer/counter.
PORT 0/ACH2–7	6-bit high impedance input-only port. These pins can be used as digital inputs and/or as analog inputs to the on-chip A/D converter. These pins are also used as inputs to EPROM parts to select the Programming Mode.
P6.4–6.7/SSIO	Dual function I/O ports that have a system function as Synchronous Serial I/O. Two pins are clocks and two pins are data, providing full duplex capability.
PORT 2	6-bit multi-functional port. All of its pins are shared with other functions.
PORT 3 and 4	8-bit bidirectional I/O ports with open drain outputs. These pins are shared with the multiplexed address/data bus which has strong internal pullups.
TXCAN	Push-pull output to the CAN bus line.
RXCAN	High-impedance input-only from the CAN bus line.

## 4.0 Electrical Characteristics

**Note:** This document contains information on products in production. The specifications are subject to change without notice.

### 4.1 Absolute Maximum Ratings

**Table 3. Absolute Maximum Ratings**

Parameter	Maximum Rating
Storage Temperature	-60°C to +150°C
Voltage from $V_{PP}$ or EA# to $V_{SS}$ or ANGND	-0.5 V to +13.0 V
Voltage from any other pin to $V_{SS}$ or ANGND	-0.5 V to +7.0 V
Power Dissipation	0.5 W

**Warning:** Stressing the device beyond the “Absolute Maximum Ratings” may cause permanent damage. These are stress ratings only.

### 4.2 Operating Conditions

**Table 4. Operating Conditions**

Parameter	Values
$T_A$ (Ambient Temperature Under Bias)	-40°C to +125°C
$V_{CC}$ (Digital Supply Voltage)	4.75 V to 5.25 V
$V_{REF}$ (Analog Supply Voltage) (Notes 1, 2)	4.75 V to 5.25 V
$F_{OSC}$ (Oscillator Frequency):	4 MHz to 18 MHz <sup>(2)</sup>

**NOTE:**

1. ANGND and  $V_{SS}$  should be nominally at the same potential.
2. Device is static and should operate below 1 Hz, but only tested down to 4 MHz.

**Warning:** Operation beyond the “Operating Conditions” is not recommended and extended exposure beyond the “Operating Conditions” may affect device reliability.

## 4.3 DC Characteristics

**Table 5. DC Characteristics (Sheet 1 of 2)**

Symbol	Parameter	Min	Typical	Max	Units	Test Conditions
$I_{CC}$	$V_{CC}$ supply current (-40°C to +125°C ambient)		50	90	mA	$X_{TAL1} = 18\text{ MHz}$ , $V_{CC} = V_{PP} = V_{REF} = 5.25\text{ V}$ (While device is in reset)
$I_{CC1}$	Active mode supply current (typical)		50		mA	
$I_{REF}$	A/D reference supply current		2	5	mA	
$I_{IDLE}$	Idle mode current		15	40	mA	$X_{TAL1} = 18\text{ MHz}$ , $V_{CC} = V_{PP} = V_{REF} = 5.25\text{ V}$
$I_{PD}$	Powerdown mode current		50		$\mu\text{A}$	$V_{CC} = V_{PP} = V_{REF} = 5.25\text{ V}$ (Note 4)
$V_{IL}$	Input low voltage (all pins)	-0.5 V		$0.3 V_{CC}$	V	
$V_{IH}$	Input high voltage (all pins)	$0.7 V_{CC}$		$V_{CC} + 0.5$	V	(Note 5)
$V_{OL}$	Output low voltage (outputs configured as push/pull)			0.3 0.45 1.5	V	$I_{OL} = 200\ \mu\text{A}$ (Note 3) $I_{OL} = 3.2\ \text{mA}$ $I_{OL} = 7.0\ \text{mA}$
$V_{OH}$	Output high voltage (outputs configured as complementary)	$V_{CC} - 0.3$ $V_{CC} - 0.7$ $V_{CC} - 1.5$			V	$I_{OH} = -200\ \mu\text{A}$ (Note 3) $I_{OH} = -3.2\ \text{mA}$ $I_{OH} = -7.0\ \text{mA}$
$I_{LI}$	Input leakage current (standard inputs)			$\pm 10$	$\mu\text{A}$	$V_{SS} \leq V_{IN} \leq V_{CC}$ (Note 2)
$I_{LI1}$	Input leakage current (Port 0—A/D inputs)			$\pm 1.5$	$\mu\text{A}$	$V_{SS} \leq V_{IN} \leq V_{CC}$
$I_{IH}$	Input high current (NMI pin)			+175	$\mu\text{A}$	$V_{SS} \leq V_{IN} \leq V_{CC}$
$V_{OH1}$	SLPINT (P5.4) and HLDA (P2.6) Output high voltage in RESET	2.0			V	$I_{OH} = 0.8\ \text{mA}$ (Note 8)
$V_{OH2}$	Output high voltage in RESET	$V_{CC} - 1\text{ V}$			V	$I_{OH} = -15\ \mu\text{A}$ (Notes 1, 6)
$I_{OH2}$	Output High Current in RESET	-30 -75 -90		-120 -240 -280	$\mu\text{A}$	$V_{OH2} = V_{CC} - 1.0\text{ V}$ $V_{OH2} = V_{CC} - 2.5\text{ V}$ $V_{OH2} = V_{CC} - 4.0\text{ V}$

**NOTES:**

- All BD (bidirectional) pins except P5.5/INST and P2.7/CLKOUT which are excluded due to their not being weakly pulled high in reset. BD pins include Port1, Port 2, Port3, Port4, Port5, and Port6.
- Standard Input pins include XTAL1, EA#, RESET#, and Ports 1,2,3,4,5,6 when configured as inputs.
- All bidirectional I/O pins when configured as outputs (push/pull).
- Typicals are based on limited number of samples and are not guaranteed. The values listed are at room temperature and  $V_{REF} = V_{CC} = 5.0\text{ V}$ .
- $V_{IH}$  max for Port0 is  $V_{REF} + 0.5\text{ V}$ .
- Refer to "VOH2/IOH2 Specification" errata #1 in errata section of this datasheet.
- This specification is not tested in production and is based upon theoretical estimates and/or product characterization.
- Violating these specifications in reset may cause the device to enter test modes (P5.4 and P2.6).

**Table 5. DC Characteristics (Sheet 2 of 2)**

Symbol	Parameter	Min	Typical	Max	Units	Test Conditions
R <sub>RST</sub>	Reset pullup resistor	6 K		65 K	Ω	
V <sub>OL3</sub>	Output low voltage in reset (RESET pin only)			0.3 0.5 0.8	V	I <sub>OL3</sub> = 4 mA (Note 7) I <sub>OL3</sub> = 6 mA I <sub>OL3</sub> = 10 mA
C <sub>S</sub>	Pin Capacitance (any pin to V <sub>SS</sub> )			10	pF	F <sub>TEST</sub> = 1.0 MHz
R <sub>WPU</sub>	Weak pullup resistance (approx.)		150 K		Ω	(Note 4)

**NOTES:**

1. All BD (bidirectional) pins except P5.5/INST and P2.7/CLKOUT which are excluded due to their not being weakly pulled high in reset. BD pins include Port1, Port 2, Port3, Port4, Port5, and Port6.
2. Standard Input pins include XTAL1, EA#, RESET#, and Ports 1,2,3,4,5,6 when configured as inputs.
3. All bidirectional I/O pins when configured as outputs (push/pull).
4. Typicals are based on limited number of samples and are not guaranteed. The values listed are at room temperature and V<sub>REF</sub> = V<sub>CC</sub> = 5.0 V.
5. V<sub>IH</sub> max for Port0 is V<sub>REF</sub> + 0.5 V.
6. Refer to "VOH2/IOH2 Specification" errata #1 in errata section of this datasheet.
7. This specification is not tested in production and is based upon theoretical estimates and/or product characterization.
8. Violating these specifications in reset may cause the device to enter test modes (P5.4 and P2.6).

**Figure 4. 87C196CA I<sub>CC</sub> vs. Frequency**

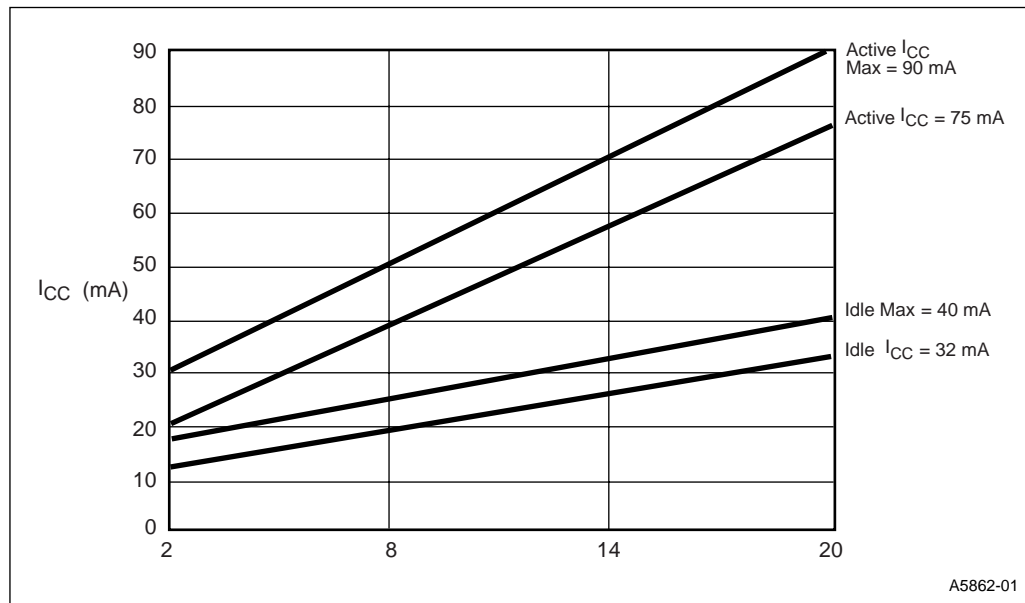

## 4.4 AC Characteristics

**Table 6. AC Characteristics (Sheet 1 of 2)**

(over specified operating conditions); Test conditions: capacitance load on all pins = 100 pF, Rise and fall times = 10 ns,  $F_{OSC} = 18$  MHz

Symbol	Parameter	Min	Max	Units
<b>The system must meet these specifications to work with the 87C196CA Microcontroller.</b>				
$T_{AVYV}$	Address Valid to READY Setup		$2 T_{OSC} - 75$	ns
$T_{LLYV}$	ALE Low to READY Setup		$T_{OSC} - 70$	ns
$T_{YLYH}$	Non Ready Time	No Upper Limit		ns
$T_{CLYX}$	READY Hold after CLKOUT Low	0	$T_{OSC} - 30$	ns <sup>(1)</sup>
$T_{LLYX}$	READY Hold after ALE Low	$T_{OSC} - 15$	$2 T_{OSC} - 40$	ns <sup>(1)</sup>
$T_{AVDV}$	Address Valid to Input Data Valid		$3 T_{OSC} - 55$	ns
$T_{RLDV}$	RD# Active to Input Data Valid		$T_{OSC} - 22$	ns
$T_{CLDV}$	CLKOUT Low to Input Data Valid		$T_{OSC} - 50$	ns
$T_{RHDZ}$	End of RD# to Input Data Float		$T_{OSC}$	ns
$T_{RXDX}$	Data Hold after RD# Inactive	0		ns
<b>The 87C196CA Microcontroller meets these specifications.</b>				
$F_{XTAL}$	Oscillator Frequency	4	18	MHz <sup>(2)</sup>
$T_{OSC}$	Oscillator Period ( $1/F_{XTAL}$ )	55	250	ns
$T_{XHCH}$	XTAL1 High to CLKOUT High or Low	20	110	ns <sup>(3)</sup>
$T_{OFD}$	Clock Failure to Reset Pulled Low	4	40	$\mu$ S <sup>(7)</sup>
$T_{CLCL}$	CLKOUT Period	$2 T_{OSC}$		ns
$T_{CHCL}$	CLKOUT High Period	$T_{OSC} - 10$	$T_{OSC} + 15$	ns
$T_{CLLH}$	CLKOUT Falling Edge to ALE Rising	-15	10	ns
$T_{LLCH}$	ALE/ADV# Falling Edge to CLKOUT Rising	-20	15	ns
$T_{LHLH}$	ALE/ADV# Cycle Time	$4 T_{OSC}$		ns
$T_{LHLL}$	ALE/ADV# High Period	$T_{OSC} - 10$	$T_{OSC} + 10$	ns
$T_{AVLL}$	Address Setup to ALE/ADV# Falling Edge	$T_{OSC} - 15$		ns
$T_{LLAX}$	Address Hold after ALE/ADV# Falling Edge	$T_{OSC} - 40$		ns
$T_{LLRL}$	ALE/ADV# Falling Edge to RD# Falling Edge	$T_{OSC} - 30$		ns
$T_{RLCL}$	RD# Low to CLKOUT Falling Edge	4	30	ns
$T_{RLRH}$	RD# Low Period	$T_{OSC} - 10$		ns

**NOTES:**

1. If max is exceeded, additional wait states will occur.
2. Testing performed at 4 MHz; however, the device is static by design and will typically operate below 1 Hz.
3. Typical specifications, not guaranteed.
4. Assuming back-to-back bus cycles.
5. 8-bit bus only.
6.  $T_{RLAZ}$  (max) = 5 ns by design.
7.  $T_{OFD}$  is the time for the oscillator fail detect circuit (OFD) to react to a clock failure.

**Table 6. AC Characteristics (Sheet 2 of 2)**

(over specified operating conditions); Test conditions: capacitance load on all pins = 100 pF, Rise and fall times = 10 ns,  $F_{OSC} = 18$  MHz

Symbol	Parameter	Min	Max	Units
$T_{RHLH}$	RD# Rising Edge to ALE/ADV# Rising Edge	$T_{OSC}$	$T_{OSC} + 25$	ns <sup>(4)</sup>
$T_{RLAZ}$	RD# Low to Address Float		5	ns <sup>(6)</sup>
$T_{LLWL}$	ALE/ADV# Falling Edge to WR# Falling Edge	$T_{OSC} - 10$		ns
$T_{CLWL}$	CLKOUT Low to WR# Falling Edge	-5	25	ns
$T_{QVWH}$	Data Stable to WR# Rising Edge	$T_{OSC} - 23$		ns
$T_{CHWH}$	CLKOUT High to WR# Rising Edge	-10	15	ns
$T_{WLWH}$	WR# Low Period	$T_{OSC} - 20$		ns
$T_{WHQX}$	Data Hold after WR# Rising Edge	$T_{OSC} - 25$		ns
$T_{WHLH}$	WR# Rising Edge to ALE/ADV# Rising Edge	$T_{OSC} - 10$	$T_{OSC} + 15$	ns <sup>(4)</sup>
$T_{WHBX}$	BHE# Hold after WR# Rising Edge	$T_{OSC} - 10$		ns
$T_{WHAX}$	AD[15:8] Hold after WR# Rising Edge	$T_{OSC} - 30$		ns <sup>(5)</sup>
$T_{RHBX}$	BHE# Hold after RD# Rising Edge	$T_{OSC} - 10$		ns
$T_{RHAX}$	AD[15:8] Hold after RD# Rising Edge	$T_{OSC} - 30$		ns <sup>(5)</sup>

**NOTES:**

1. If max is exceeded, additional wait states will occur.
2. Testing performed at 4 MHz; however, the device is static by design and will typically operate below 1 Hz.
3. Typical specifications, not guaranteed.
4. Assuming back-to-back bus cycles.
5. 8-bit bus only.
6.  $T_{RLAZ}$  (max) = 5 ns by design.
7.  $T_{OFD}$  is the time for the oscillator fail detect circuit (OFD) to react to a clock failure.



Figure 5. System Bus Timing

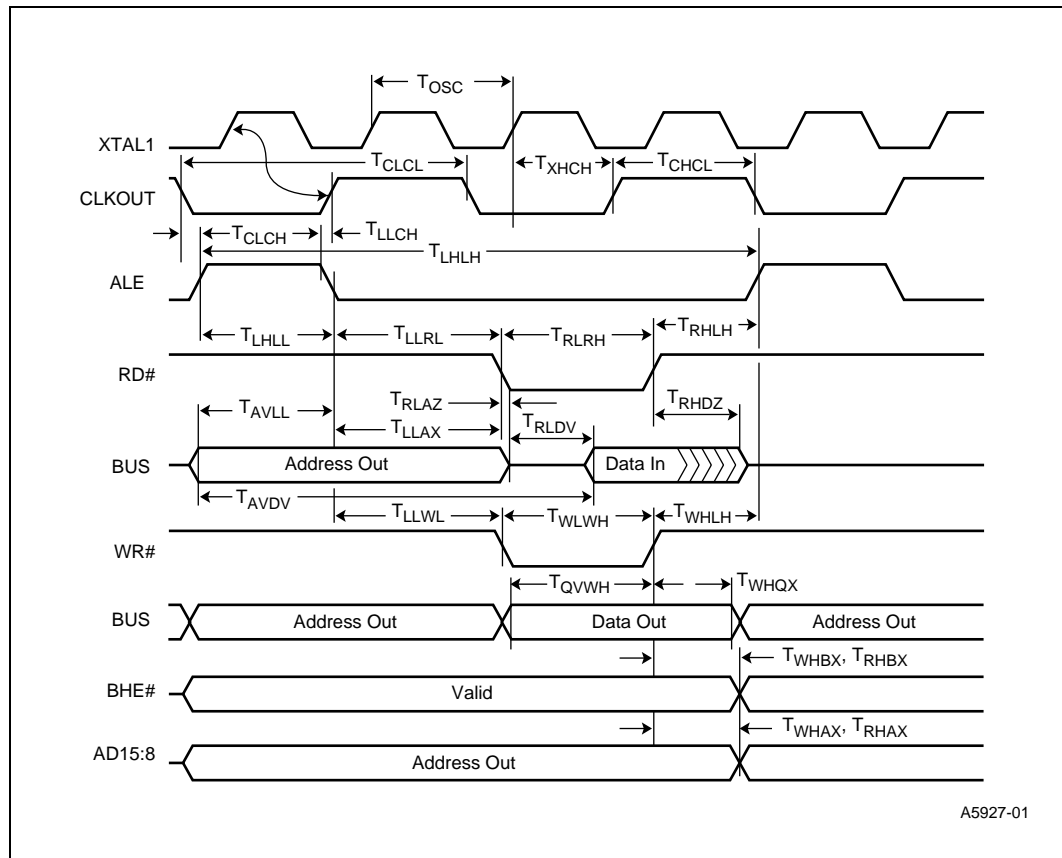
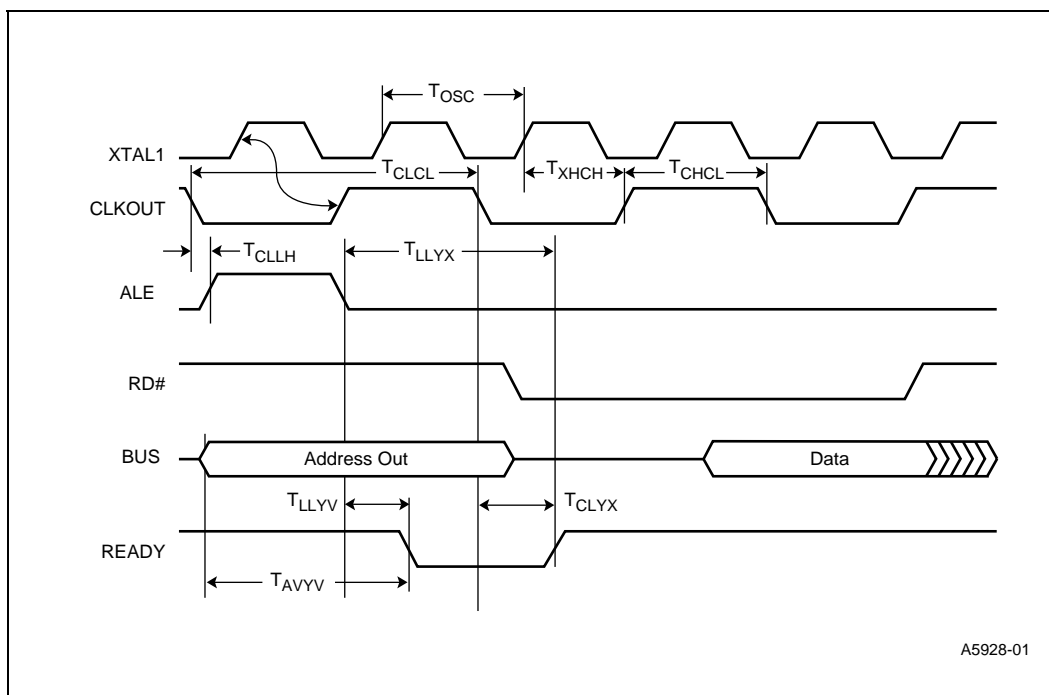

Figure 6. READY Timing



A5928-01

Table 7. External Clock Drive

Symbol	Parameter	Min	Max	Units
$1/T_{XLXL}$	Oscillator Frequency	4	18	MHz
$T_{XLXL}$	Oscillator Period ( $T_{OSC}$ )	55	250	ns
$T_{XHXX}$	High Time	$0.35 T_{OSC}$	$0.65 T_{OSC}$	ns
$T_{XLXX}$	Low Time	$0.35 T_{OSC}$	$0.65 T_{OSC}$	ns
$T_{XLXH}$	Rise Time		10	ns
$T_{XHXL}$	Fall Time		10	ns

Figure 7. External Clock Drive Waveforms

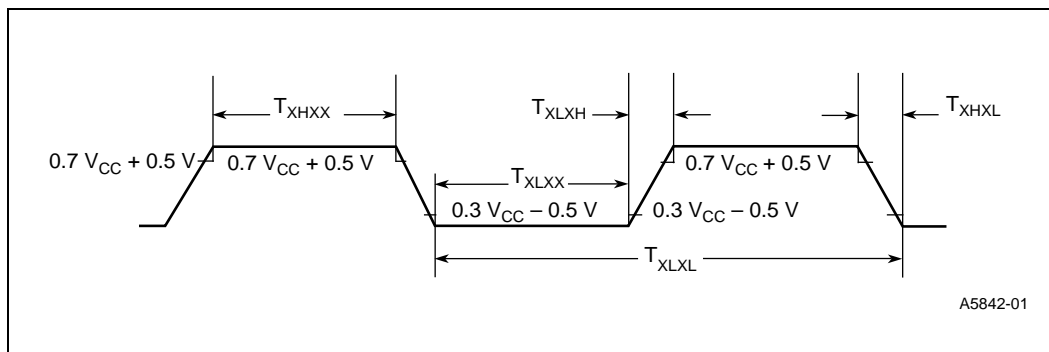

A5842-01

Figure 8. AC Testing Input, Output Waveforms

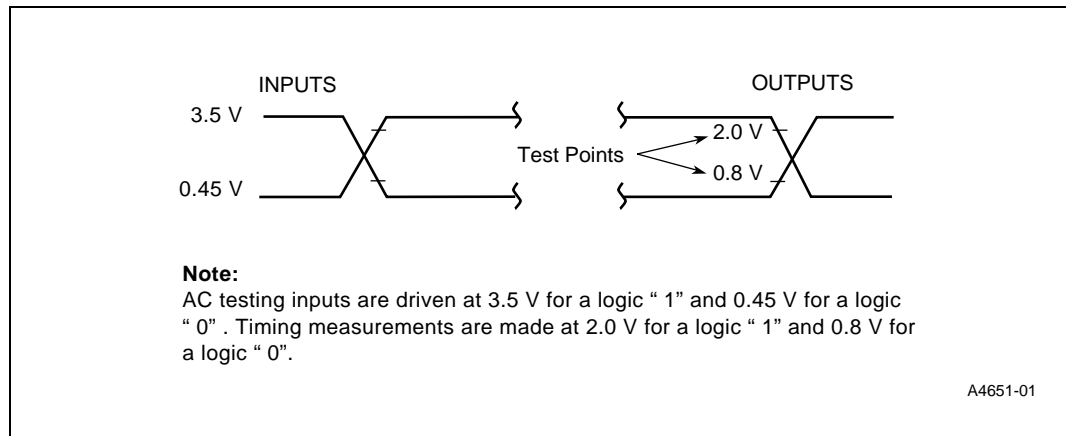

Figure 9. Float Waveforms

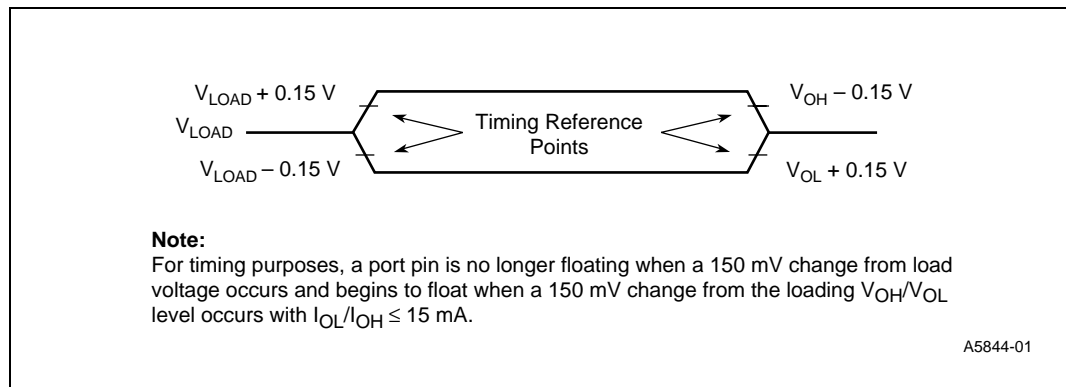

Table 8. Thermal Characteristics

Device and Package	$\theta_{JA}$	$\theta_{JC}$
AN87C196CA (68-Lead PLCC)	36.5°C/W	10°C/W

**NOTES:**

- $\theta_{JA}$  = Thermal resistance between junction and the surrounding environment (ambient). Measurements are taken 1 ft. away from case in air flow environment.  
 $\theta_{JC}$  = Thermal resistance between junction and package surface (case).
- All values of  $\theta_{JA}$  and  $\theta_{JC}$  may fluctuate depending on the environment (with or without airflow, and how much airflow) and device power dissipation at temperature of operation. Typical variations are  $\pm 2^\circ\text{C}/\text{W}$ .
- Values listed are at a maximum power dissipation of 0.50 W.

#### 4.4.1 Explanation of AC Symbols

Each symbol is two pairs of letters prefixed by “t” for time. The characters in a pair indicate a signal and its condition, respectively. Symbols represent the time between the two signal/condition points.

Conditions	Signals	
H–High	A–Address	HA–HLDA#
L–Low	B–BHE#	L–ALE/ADV#
V–Valid	C–CLKOUT	R–RD#
X–No Longer Valid	D–DATA	W–WR#/WRH#/WRI#
Z–Floating	G–Buswidth	X–XTAL1
	H–HOLD#	Y–READY

#### 4.4.2 EPROM Specifications

**Table 9. AC EPROM Programming Characteristics**

Operating Conditions: Load Capacitance = 150 pF; TC = 25°C ± 5°C; VREF = 5.0 V ± 0.25 V; VSS, ANGND = 0 V; VPP = 12.5 V ± 0.25 V; EA# = 12.5 V ± 0.25 V; FOSC = 5.0 MHz

Symbol	Parameter	Min	Max	Units
T <sub>AVLL</sub>	Address Setup Time	0		T <sub>OSC</sub>
T <sub>LLAX</sub>	Address Hold Time	100		T <sub>OSC</sub>
T <sub>DVPL</sub>	Data Setup Time	0		T <sub>OSC</sub>
T <sub>PLDX</sub>	Data Hold Time	400		T <sub>OSC</sub>
T <sub>LLLH</sub>	PALE# Pulse Width	50		T <sub>OSC</sub>
T <sub>PLPH</sub>	PROG# Pulse Width <sup>(3)</sup>	50		T <sub>OSC</sub>
T <sub>LHPL</sub>	PALE# High to PROG# Low	220		T <sub>OSC</sub>
T <sub>PHLL</sub>	PROG# High to Next PALE# Low	220		T <sub>OSC</sub>
T <sub>PHDX</sub>	Word Dump Hold Time		50	T <sub>OSC</sub>
T <sub>PHPL</sub>	PROG# High to Next PROG# Low	220		T <sub>OSC</sub>
T <sub>PLDV</sub>	PROG# Low to Word Dump Valid		50	T <sub>OSC</sub>
T <sub>SHELL</sub>	RESET# High to First PALE# Low	1100		T <sub>OSC</sub>
T <sub>PHIL</sub>	PROG# High to AINC# Low	0		T <sub>OSC</sub>
T <sub>ILIH</sub>	AINC# Pulse Width	240		T <sub>OSC</sub>
T <sub>ILVH</sub>	PVER Hold after AINC# Low	50		T <sub>OSC</sub>
T <sub>ILPL</sub>	AINC# Low to PROG# Low	170		T <sub>OSC</sub>
T <sub>PHVL</sub>	PROG# High to PVER# Valid		220	T <sub>OSC</sub>

**NOTES:**

- Run-time programming is done with F<sub>OSC</sub> = 6.0 MHz to 10.0 MHz, V<sub>CC</sub>, V<sub>PD</sub>, V<sub>REF</sub> = 5 V ± 0.25 V, TC = 25°C ± 5°C and V<sub>PP</sub> = 12.5 V ± 0.25 V. For run-time programming over a full operating range, contact factory.
- Programming specifications are not tested, but guaranteed by design.
- This specification is for the word dump mode. For programming pulses, use 300 T<sub>OSC</sub> + 100 μS.

Table 10. DC EPROM Programming Characteristics

Symbol	Parameter	Min	Max	Units
$I_{PP}$	$V_{PP}$ Programming Supply Current		200	mA

**NOTE:**  $V_{PP}$  must be within 1 V of  $V_{CC}$  while  $V_{CC} < 4.5$  V.  $V_{PP}$  must not have a low impedance path to ground or  $V_{SS}$  while  $V_{CC} > 4.5$  V.

Figure 10. Slave Programming Mode Data Program Mode with Single Program Pulse

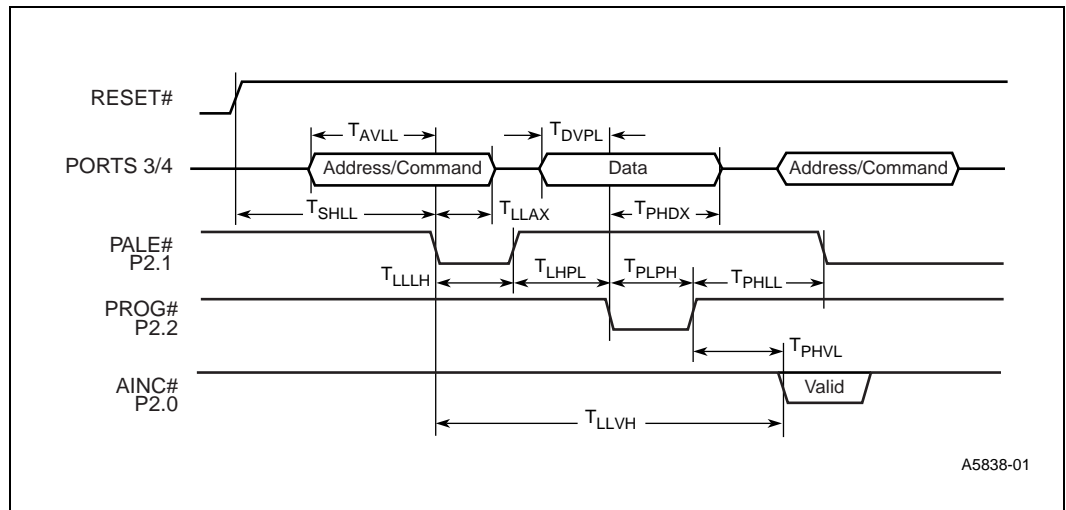
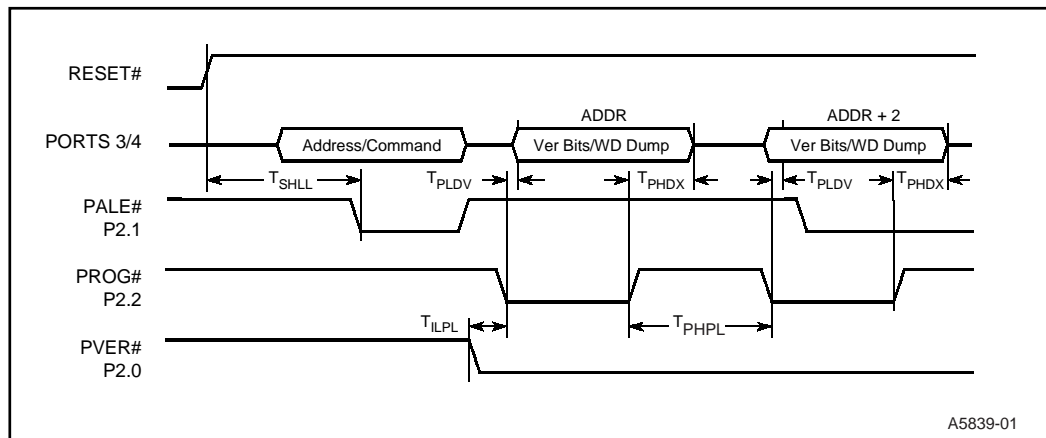
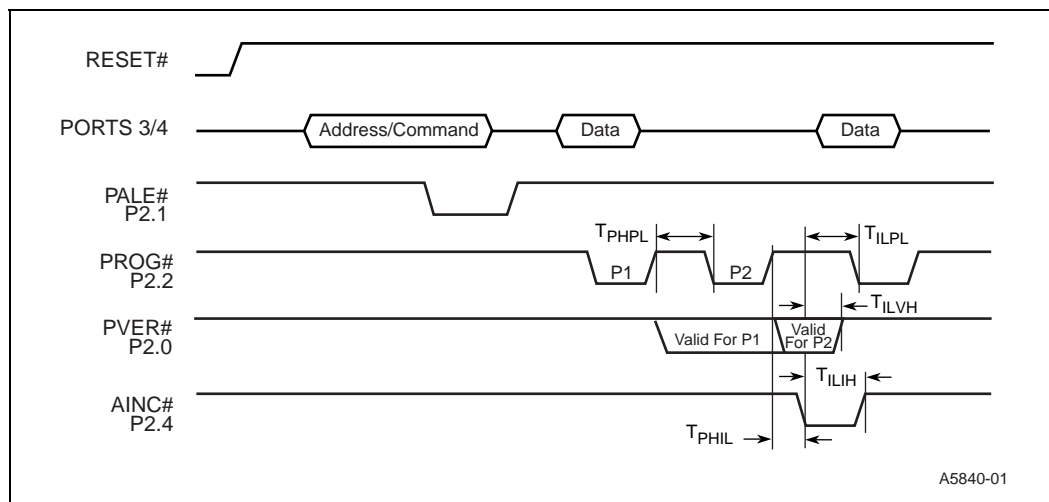

Figure 11. Slave Programming Mode in Word Dump or Data Verify Mode with Auto Increment



**Figure 12. Slave Programming Mode Timing in Data Program Mode with Repeated PROG Pulse and Auto Increment**



### 4.4.3 A to D Converter Specifications

The speed of the A/D converter in the 10-bit or 8-bit modes can be adjusted by setting the AD\_TIME special function register to the appropriate value. The AD\_TIME register only programs the speed at which the conversions are performed, not the speed at which it can convert correctly.

The converter is ratiometric, so absolute accuracy is dependent on the accuracy and stability of  $V_{REF}$ .

$V_{REF}$  must not exceed  $V_{CC}$  by more than 0.5 V since it supplies both the resistor ladder and the digital portion of the converter and input port pins.

For testing purposes, after a conversion is started, the device is placed in the IDLE mode until the conversion is complete. Testing is performed at  $V_{REF} = 5.12$  V and 18 MHz operating frequency.

There is an AD\_TEST register that allows for conversion on ANGND and  $V_{REF}$  as well as zero offset adjustment. The absolute error listed is without doing any adjustments.

**Table 11. A/D Operating Conditions**

Symbol	Description	Min	Max	Units
$T_A$	Automotive Ambient Temperature	-40	+125	°C
$V_{CC}$	Digital Supply Voltage	4.75	5.25	V
$V_{REF}$	Analog Supply Voltage	4.75	5.25	V
$T_{SAM}$	Sample Time	2.0		$\mu$ S
$T_{CONV}$	Conversion Time	15	18	$\mu$ S
$F_{OSC}$	Oscillator Frequency	4	18	MHz

**NOTES:**

1. ANGND and  $V_{SS}$  should nominally be at the same potential.
2.  $V_{REF}$  must not exceed  $V_{CC}$  by more than +0.5 V.
3. Testing is performed at  $V_{REF} = 5.12$  V.
4. The value of AD\_TIME must be selected to meet these specifications.

**Table 12. A/D Operating Parameter Values**

Parameter	Typical <sup>(†,1)</sup>	Min	Max	Units <sup>††</sup>
Resolution		1024 10	1024 10	Level Bits
Absolute Error		0	-3 +3	LSBs
Full Scale Error	±2			LSBs
Zero Offset Error	±2			LSBs
Non-linearity			±3	LSBs
Differential Non-linearity		> -0.5	+0.5	LSBs
Channel-to-Channel Matching		0	±1	LSBs
Repeatability	±0.25	0		LSBs <sup>(1)</sup>
Temperature Coefficients: Offset Fullscale Differential Non-linearity	0.009 0.009 0.009			LSB/C <sup>(1)</sup>
Off Isolation		-60		dB <sup>(1)(2)(3)</sup>
Feedthrough	-60			dB <sup>(1)(2)</sup>
V <sub>CC</sub> Power Supply Rejection	-60			dB <sup>(1)(2)</sup>
Input Resistance		750	1.2 K	Ω <sup>(1)</sup>
DC Input Leakage		0	±3	μA

**NOTES:**

† These values are expected for most parts at 25°C but are not tested or guaranteed.

†† An “LSB,” as used here, has a value of approximately 5 mV. (See Automotive Handbook for A/D glossary of terms.)

1. These values are not tested in production and are based on theoretical estimates and/or laboratory test.
2. DC to 100 KHz.
3. Multiplexer break-before-make guaranteed.

## 4.4.4 AC Characteristics—Slave Port

Figure 13. Slave Port Waveform (SLPL = 0)

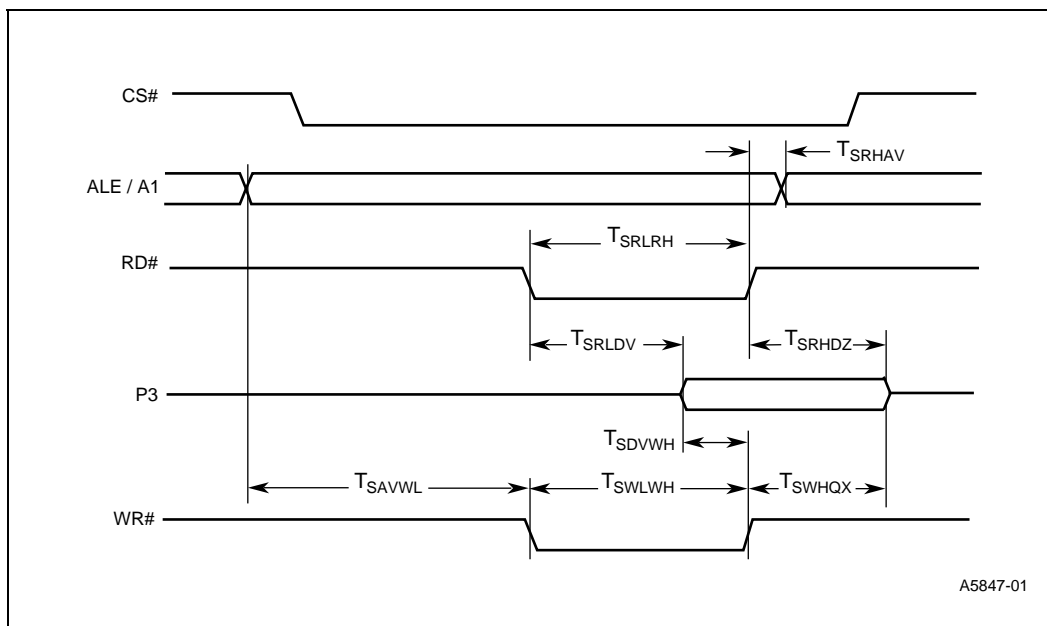

Table 13. Slave Port Timing—(SLPL = 0)

(See notes 1, 2, 3)

Symbol	Parameter	Min	Max	Units
$T_{SAVWL}$	Address Valid to WR# Low	50		ns
$T_{SRHAV}$	RD# High to Address Valid	60		ns
$T_{SRLRH}$	RD# Low Period	$T_{OSC}$		ns
$T_{SWLWH}$	WR# Low Period	$T_{OSC}$		ns
$T_{SRLDV}$	RD# Low to Output Data Valid		60	ns
$T_{SDVWH}$	Input Data Setup to WR# High	20		ns
$T_{SWHQX}$	WR# High to Data Invalid	30		ns
$T_{SRHDZ}$	RD# High to Data Float	15		ns

**NOTES:**

1. Test conditions:  $F_{OSC} = 18 \text{ MHz}$ ,  $T_{OSC} = 60 \text{ ns}$ , Rise/Fall Time = 10 ns. Capacitive Pin Load = 100 pF.
2. These values are not tested in production, and are based upon theoretical estimates and/or laboratory tests.
3. Specifications above are advanced information and are subject to change.



Figure 14. Slave Port Waveform (SLPL = 1)

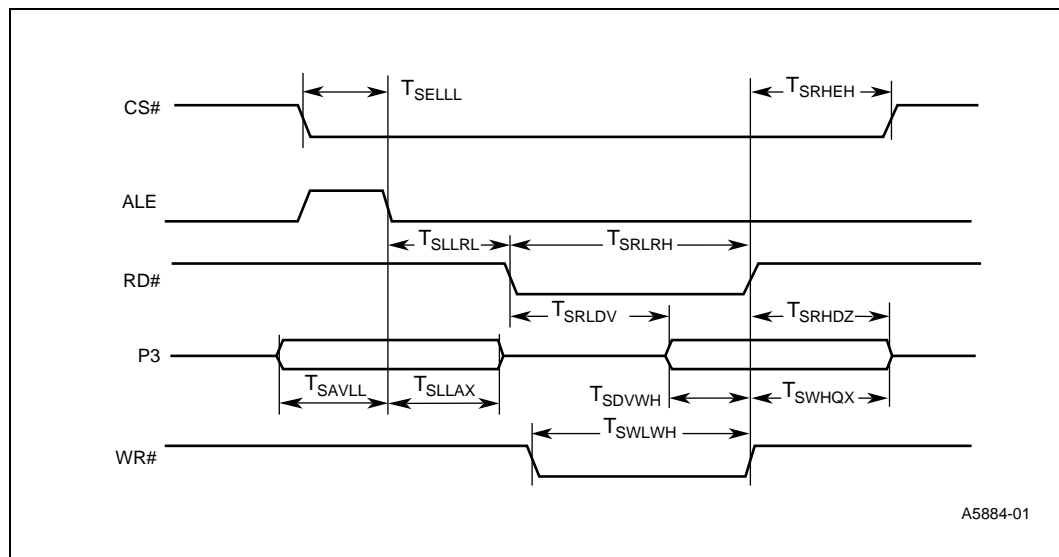

Table 14. Slave Port Timing—(SLPL = 1)

(See notes 1, 2, 3)

Symbol	Parameter	Min	Max	Units
$T_{SELL}$	CS# Low to ALE Low	20		ns
$T_{SRHEH}$	RD# or WR# High to CS# High	60		ns
$T_{SLLRL}$	ALE Low to RD# Low	$T_{OSC}$		ns
$T_{SRLRH}$	RD# Low Period	$T_{OSC}$		ns
$T_{SWLWH}$	WR# Low Period	$T_{OSC}$		ns
$T_{SAVLL}$	Address Valid to ALE Low	20		ns
$T_{SLLAX}$	ALE Low to Address Invalid	20		ns
$T_{SRLDV}$	RD# Low to Output Data Valid		60	ns
$T_{SDVWH}$	Input Data Setup to WR# High	20		ns
$T_{SWHGX}$	WR# High to Data Invalid	30		ns
$T_{SRHDZ}$	RD# High to Data Float	15		ns

**NOTES:**

1. Test conditions:  $F_{OSC} = 18 \text{ MHz}$ ,  $T_{OSC} = 60 \text{ ns}$ , Rise/Fall Time = 10 ns. Capacitive Pin Load = 100 pF.
2. These values are not tested in production, and are based upon theoretical estimates and/or laboratory tests.
3. Specifications above are advanced information and are subject to change.

### 4.4.5 AC Characteristics—Serial Port—Shift Register Mode

**Table 15. Serial Port Timing—Shift Register Mode**

Test Conditions:  $T_A = -40^{\circ}\text{C}$  to  $+125^{\circ}\text{C}$ ;  $V_{CC} = 5.0\text{ V} \pm 5\%$ ;  $V_{SS} = 0.0\text{ V}$ ; Load Capacitance = 100 pF

Symbol	Parameter	Min	Max	Units
$T_{XLXL}$	Serial Port Clock Period	$8 T_{OSC}$		ns
$T_{XLXH}$	Serial Port Clock Falling Edge to Rising Edge	$4 T_{OSC} - 50$	$4 T_{OSC} + 50$	ns
$T_{QVXH}$	Output Data Setup to Clock Rising Edge	$3 T_{OSC}$		ns
$T_{XHQX}$	Output Data Hold after Clock Rising Edge	$2 T_{OSC} - 50$		ns
$T_{XHQV}$	Next Output Data Valid after Clock Rising Edge		$2 T_{OSC} + 50$	ns
$T_{DVXH}$	Input Data Setup to Clock Rising Edge	$2 T_{OSC} + 200$		ns
$T_{XHDX}^{(1)}$	Input Data Hold after Clock Rising Edge	0		ns
$T_{XHQZ}^{(1)}$	Last Clock Rising to Output Float		$5 T_{OSC}$	ns

**NOTES:**

1. Parameter not tested.

### 4.4.6 Waveform—Serial Port—Shift Register Mode 0

**Figure 15. Serial Port Waveform—Shift Register Mode**

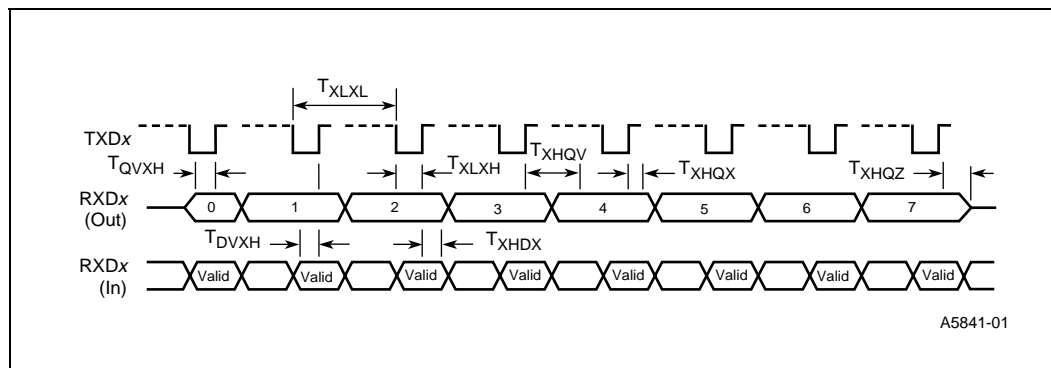

## 5.0 Design Considerations

### 5.1 87C196CA Design Considerations

#### 1. EPA Timer RESET/Write Conflict

If the user writes to the EPA timer at the same time that the timer is reset, it is indeterminate which will take precedence. Users should not write to a timer if using EPA signals to reset it.

#### 2. Valid Time Matches

The timer must increment/decrement to the compare value for a match to occur. A match does not occur if the timer is loaded with a value equal to an EPA compare value. Matches also do not occur if a timer is reset and 0 is the EPA compare value.

#### 3. P6 PIN.4-.7 Not Updated Immediately

Values written to P6 REG are temporarily held in a buffer. If P6 MODE is cleared, the buffer is loaded into P6 REG.x. If P6 MODE is set, the value stays in the buffer and is loaded into P6 REG.x when P6 MODE.x is cleared. Since reading P6 REG returns the current value in P6. REG and not the buffer, changes to P6 REG cannot be read until/unless P6 MODE.x is cleared.

#### 4. Write Cycle during Reset

If RESET occurs during a write cycle, the contents of the external memory device may be corrupted.

#### 5. Indirect Shift Instruction

The upper 3 bits of the byte register holding the shift count are not masked completely. If the shift count register has the value  $32 \times n$ , where  $n = 1, 3, 5, \text{ or } 7$ , the operand will be shifted 32 times. This should have resulted in no shift taking place.

#### 6. P2.7 (CLKOUT)

P2.7 (CLKOUT) does not operate in open drain mode.

#### 7. CLKOUT

The CLKOUT signal is active on P2.7 during RESET.

#### 8. EPA Overruns

EPA “lock-up” can occur if overruns are not handled correctly, refer to Intel Techbit #DB0459 “Understanding EPA Capture Overruns”, dated 12-9-93. Applies to EPA channels with interrupts and overruns enabled (ON/RT bit in EPA\_CONTROL register set to “1”).

#### 9. Indirect Addressing with Auto-Increment

For the special case of a pointer pointing to itself using auto-increment, an incorrect access of the incremented pointer address will occur instead of an access to the original pointer address. All other indirect auto-increment accesses will not be affected. Please refer to Techbit #MC0593.

Incorrect sequence:

```
ld ax,#ax           ;
ldb bx,[ax]+       ; Results in ax being incremented by 1 and the contents of the address
                    ; pointed to by ax+1 to be loaded into bx.
```

Correct sequence:

```
ld ax,#bx           ;
ldb cx,[ax]+       ; where ax ≠ bx. Results in the contents of the address pointed to by ax
                    ; to be loaded into bx and ax incremented by 1.
```

## 196KR Features Unsupported on the 196CA:

- Analog Channels 0 and 1
- INST Pin Functionality
- SLPINT and SLPCS Pin Support
- HLD/HLDA Functionality
- External Clocking/Direction of Timer 1
- Quadrature Clocking Timer 1
- Dynamic Buswidth
- EPA Capture Channels 4–7

## 1. External Memory

Removal of the Buswidth pin means the bus cannot dynamically switch from 8- to 16-bit bus mode or vice versa. The programmer must define the bus mode by setting the associated bits in the CCB.

## 2. Auto-Programming Mode

The 87C196CA device will ONLY support the 16-bit zero wait state bus during auto-programming.

## 3. EPA4 through EPA7

Since the CA device is based on the KR design, these functions are in the device, however there are no associated pins. A programmer can use these as compare only channels or for other functions like software timer, start an A/D conversion, or reset timers.

## 4. Slave Port Support

The Slave port can not be used on the 196CA due to a function change for P5.4/SLPINT and P5.1/SLPCS not being bonded-out.

## 5. Port Functions

Some port pins have been removed. P5.1, P6.2, P6.3, P1.4 through P1.7, P2.3, P2.5, P0.0 and P0.1. The PxREG, PxSSEL, and PxIO registers can still be updated and read. The programmer should not use the corresponding bits associated with the removed port pins to conditionally branch in software. Treat these bits as RESERVED.

Additionally, these port pins should be setup internally by software as follows:

- a. Written to PxREG as “1” or “0”.
- b. Configured as Push/Pull, PxIO as “0”.
- c. Configured as LSIO.

This configuration will effectively strap the pin either high or low. DO NOT Configure as Open Drain output “1”, or as an Input pin. This device is CMOS.

## 6. EPA Timer RESET/Write Conflict

If the user writes to the EPA timer at the same time that the timer is reset, it is indeterminate which will take precedence. Users should not write to a timer if using EPA signals to reset it.

## 7. Valid Time Matches

The timer must increase/decrease to the compare value for a match to occur. A match does not occur if the timer is loaded with a value equal to an EPA compare value. Matches also do not occur if a timer is reset and 0 is the EPA compare value.

## 8. Write Cycle during Reset

If RESET occurs during a write cycle, contents of the external memory device may be corrupted.

## 9. Indirect Shift Instruction

The upper 3 bits of the byte register holding the shift count are not masked completely. If the shift count register has the value  $32 \cdot n$ , where  $n \in \{1, 3, 5, 7\}$ , the operand will be shifted 32 times. This should have resulted in no shift taking place.

## 10. P2.7 (CLKOUT)

P2.7 (CLKOUT) does not operate in open drain mode.

## 6.0 Revision History

---

Revision	Date	Description
001	06/98	Initial release.

