

**WHITE LED STEP-UP CONVERTER****AP3009****General Description**

The AP3009 is an inductor-based DC/DC converter designed to drive up to six white LEDs in series for backlight. Only one feedback resistor is needed to control the LED current and obtain satisfied brightness.

A constant frequency 1.2MHz PWM control scheme is employed in this IC, which means the tiny external components can be used. In fact, 1mm tall inductor and 0.22 μ F output capacitor for the typical application is very appropriate. Additionally, the schottky diode in boost circuit is integrated in this chip. AP3009 also provide a disable port to ease its use for different systems.

The over output voltage protection is equipped in AP3009. When any LED is broken or in other abnormal conditions, the output voltage will be clamped to 30V.

The AP3009 is available in standard SOT-23-6 package.

Features

- Inherently Uniform LED Current
- High Efficiency: 83% Typical
- No Need for Extra Schottky Diode
- Over Output Voltage Protection
- Drives 2 to 6 LEDs
- Fast 1.2MHz Switching Frequency
- Uses Tiny 1mm Tall Inductor
- Requires Only 0.22 μ F Output Capacitor

Applications

- Cellular Phones
- Digital Cameras
- LCD modules
- GPS Receivers
- PDAs, Handheld Computers

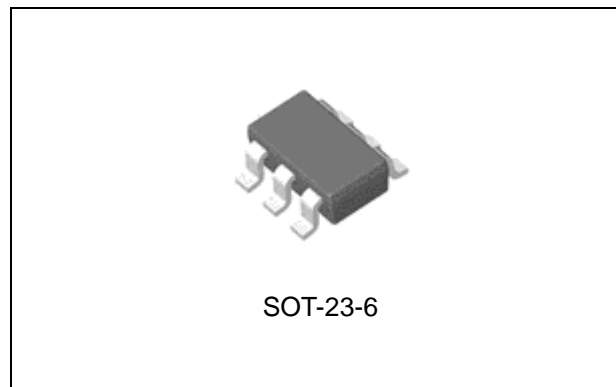

Figure 1. Package Type of AP3009

**WHITE LED STEP-UP CONVERTER****AP3009****Pin Configuration**

Figure 2. Pin Configuration of AP3009 (Top View)

Pin Description

Pin Number	Pin Name	Function
1	V _{OUT}	Output Pin. Connected to the cathode of internal schottky diode
2	GND	Ground Pin
3	FB	Voltage Feedback. Reference voltage is 200mV
4	CTRL	Shutdown and Dimming Pin. Connect to 1.8V or higher to enable device; Connect to 50mV or less to disable device; Connect to a voltage between 1.8V and 50mV to achieve linear dimming
5	V _{IN}	Input Supply Pin. Must be locally bypassed
6	SW	Switch Pin. Connect external inductor

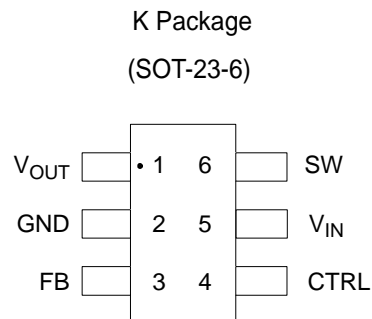

WHITE LED STEP-UP CONVERTER

AP3009

Functional Block Diagram

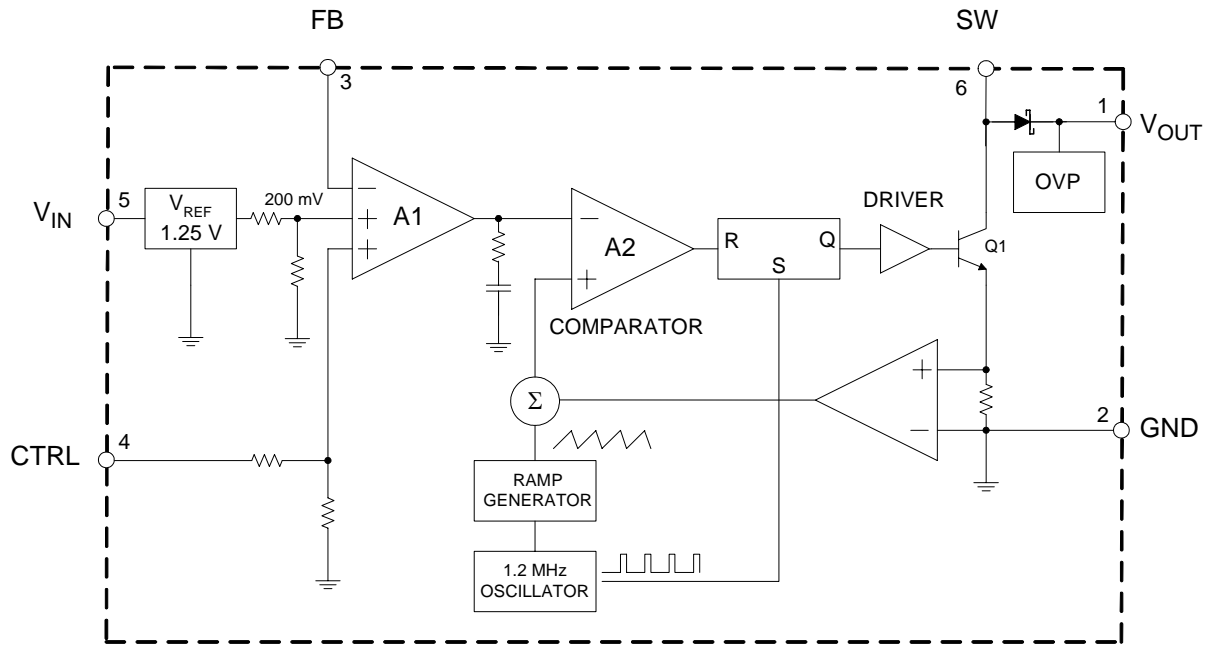
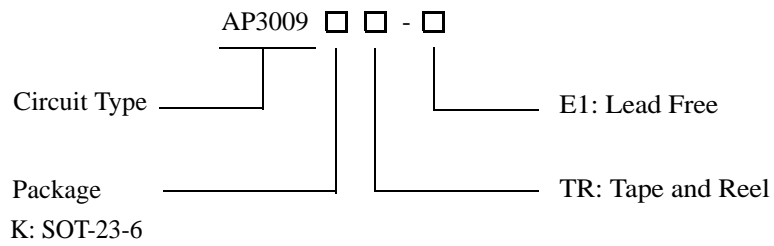

Figure 3. Functional Block Diagram of AP3009

Ordering Information



Package	Temperature Range	Part Number	Marking ID	Packing Type
SOT-23-6	-40 to 85°C	AP3009KTR-E1	E9T	Tape & Reel

BCD Semiconductor's Pb-free products, as designated with "E1" suffix in the part number, are RoHS compliant.

**WHITE LED STEP-UP CONVERTER****AP3009****Absolute Maximum Ratings (Note 1)**

Parameter	Symbol	Value	Unit
Input Voltage	V_{IN}	20	V
SW Voltage		30	V
FB Voltage		20	V
CTRL Voltage		20	V
Thermal Resistance (Junction to Atmosphere, no Heat sink)	$R_{\theta JA}$	265	°C/W
Operating Junction Temperature		150	°C
Storage Temperature Range	T_{STG}	-65 to 150	°C
Lead Temperature (Soldering, 10sec)	T_{LEAD}	260	°C
ESD (Machine Model)		250	V
ESD (Human Body Model)		2000	V

Note 1: Stresses greater than those listed under "Absolute Maximum Ratings" may cause permanent damage to the device. These are stress ratings only, and functional operation of the device at these or any other conditions beyond those indicated under "Recommended Operating Conditions" is not implied. Exposure to "Absolute Maximum Ratings" for extended periods may affect device reliability.

Recommended Operating Conditions

Parameter	Symbol	Min	Max	Unit
Operating Temperature Range	T_{OP}	-40	85	°C
Input Voltage	V_{IN}	2.5	16	V
CTRL Voltage	V_{CTRL}		16	V



WHITE LED STEP-UP CONVERTER

AP3009

Electrical Characteristics

($V_{IN}=3V$, $V_{CTRL}=3V$, $T_A=25^{\circ}C$, unless otherwise specified.)

Parameter	Symbol	Conditions	Min	Typ	Max	Unit
Minimum Operating Voltage	$V_{IN(min)}$		2.5			V
Maximum Operating Voltage	$V_{IN(max)}$				16	
Feedback Voltage	V_{FB}	$I_{OUT}=20mA$, 4 LEDs, $T_A=-40^{\circ}C$ to $85^{\circ}C$	188	200	212	mV
FB Pin Bias Current	I_{FB}			35	100	nA
Supply Current	I_{CC}	$V_{FB}=V_{IN}$, Not Switching	1.9	2.6	3.3	mA
Supply Current	I_Q	$V_{CTRL}=0V$	2.0	3.2	5.0	μA
Switching Frequency	f		0.8	1.2	1.6	MHz
Maximum Duty Cycle	D_{MAX}		90	93		%
Switch Current Limit (Note 2)	I_{LIMIT}	$T_A=25^{\circ}C$, $D=40\%$		560		mA
		$T_A=25^{\circ}C$, $D=80\%$		465		
Switch V_{CE} Saturation Voltage	V_{CESAT}	$I_{SW}=250mA$		300		mV
Switch Leakage Current		$V_{SW}=5V$		0.01	5	μA
CTRL Pin Voltage	V_{CTRL}	High	1.8			V
		Low			0.05	
CTRL Pin Bias Current	I_{CTRL}		48	60	72	μA
		$T_A=85^{\circ}C$	40	50	60	
		$T_A=-40^{\circ}C$	60	75	90	
Schottky Forward Drop	V_{DROP}	$I_D=150mA$		0.7		V
Schottky Leakage Current		$V_R=25V$			4	μA
		$V_R=30V$		90		

Note 2: The Switch Current Limit is related to Duty Cycle. Please refer to Figure 16 for detail.



WHITE LED STEP-UP CONVERTER

AP3009

Typical Performance Characteristics

(V_F of WLED is 3.45V @ $I_F=20mA$, unless otherwise noted)

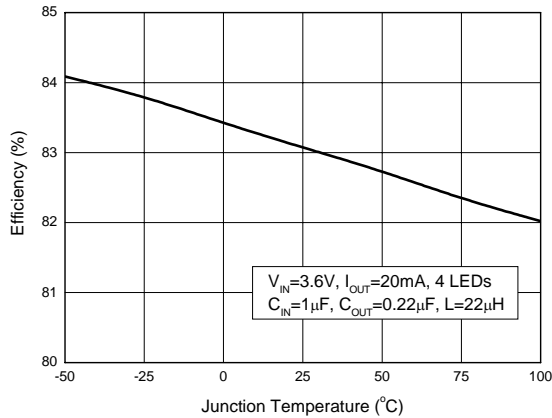

Figure 4. Efficiency vs. Junction Temperature

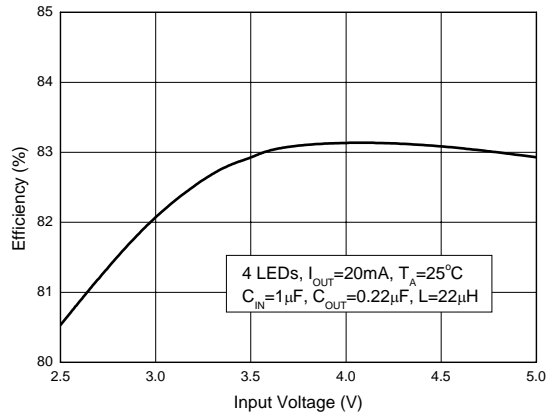

Figure 5. Efficiency vs. Input Voltage

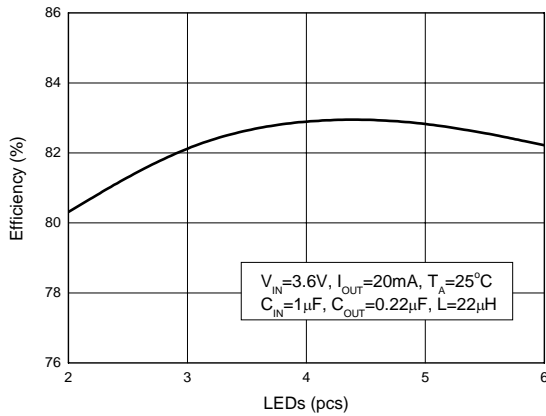

Figure 6. Efficiency vs. LED's Number

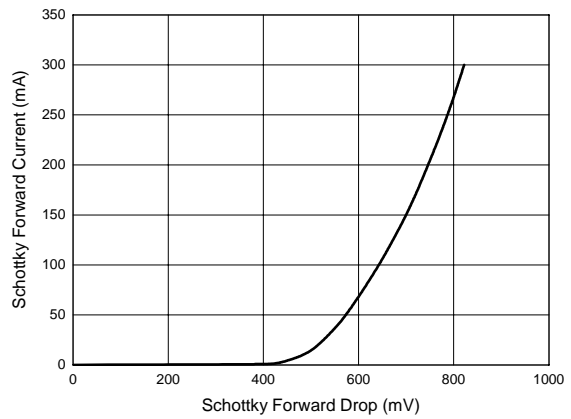

Figure 7. Schottky Forward Current vs. Schottky Forward Drop



WHITE LED STEP-UP CONVERTER

AP3009

Typical Performance Characteristics (Continued)

(V_F of WLED is 3.45V @ $I_F=20\text{mA}$, unless otherwise noted)

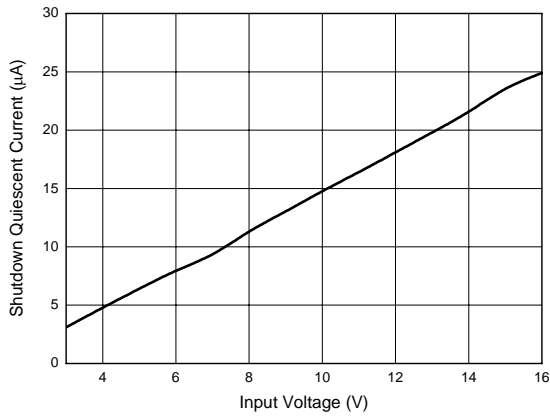

Figure 8. Shutdown Quiescent Current vs. Input Voltage

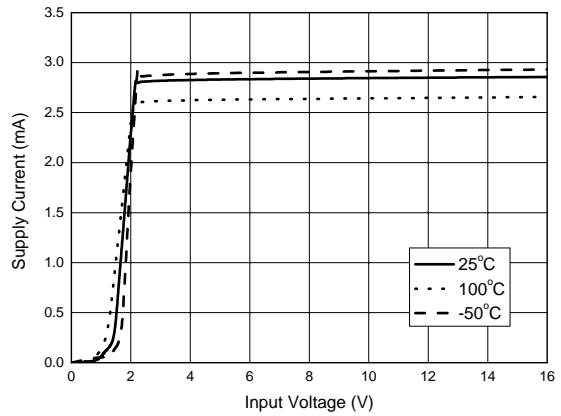

Figure 9. Supply Current vs. Input Voltage

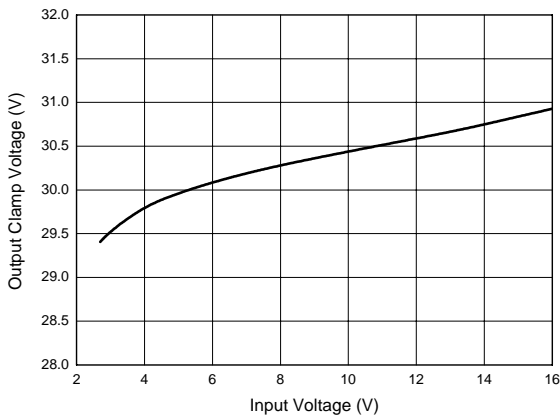

Figure 10. Output Clamp Voltage vs. Input Voltage

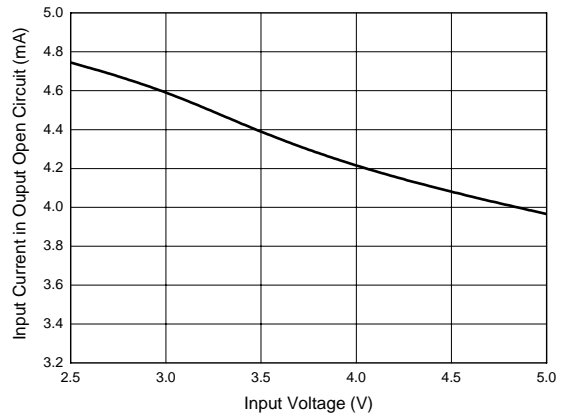

Figure 11. Input Current in Output Open Circuit vs. Input Voltage



WHITE LED STEP-UP CONVERTER

AP3009

Typical Performance Characteristics (Continued)

(V_F of WLED is 3.45V @ $I_F=20mA$, unless otherwise noted)

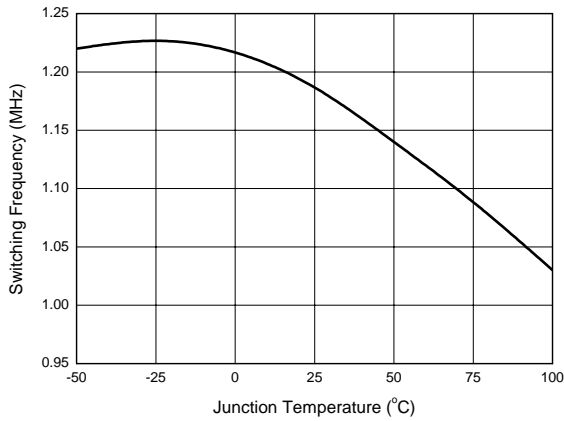

Figure 12. Switching Frequency vs. Junction Temperature

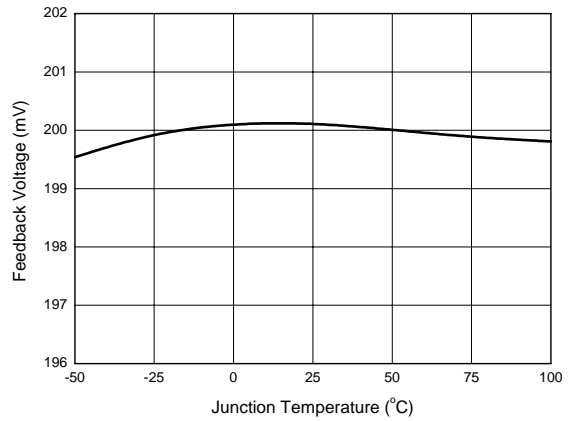

Figure 13. Feedback Voltage vs. Junction Temperature

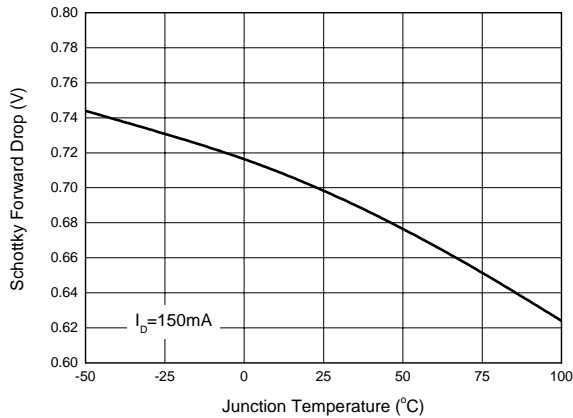

Figure 14. Schottky Forward Drop vs. Junction Temperature

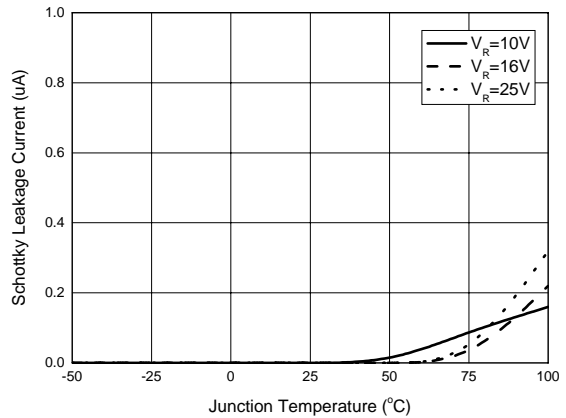

Figure 15. Schottky Leakage Current vs. Junction Temperature



WHITE LED STEP-UP CONVERTER

AP3009

Typical Performance Characteristics (Continued)

(V_F of WLED is 3.45V @ $I_F=20mA$, unless otherwise noted)

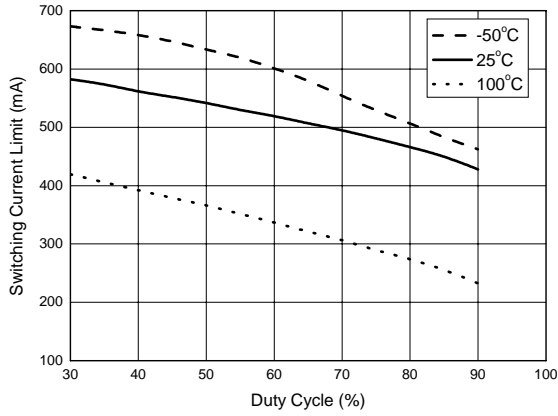

Figure 16. Switch Current Limit vs. Duty Cycle

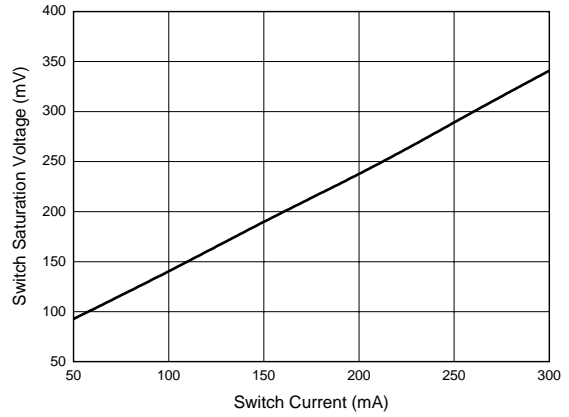

Figure 17. Switch Saturation Voltage vs. Switch Current

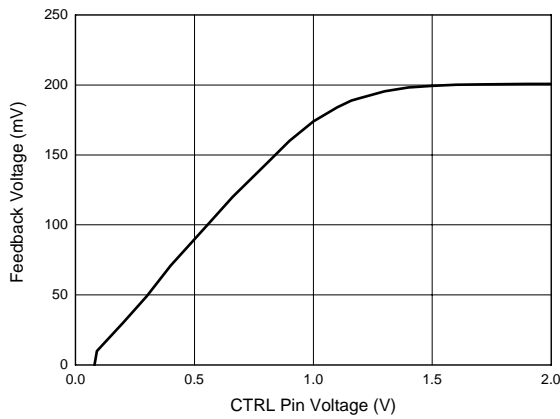

Figure 18. Feedback Voltage vs. CTRL Pin Voltage



WHITE LED STEP-UP CONVERTER

AP3009

Typical Application

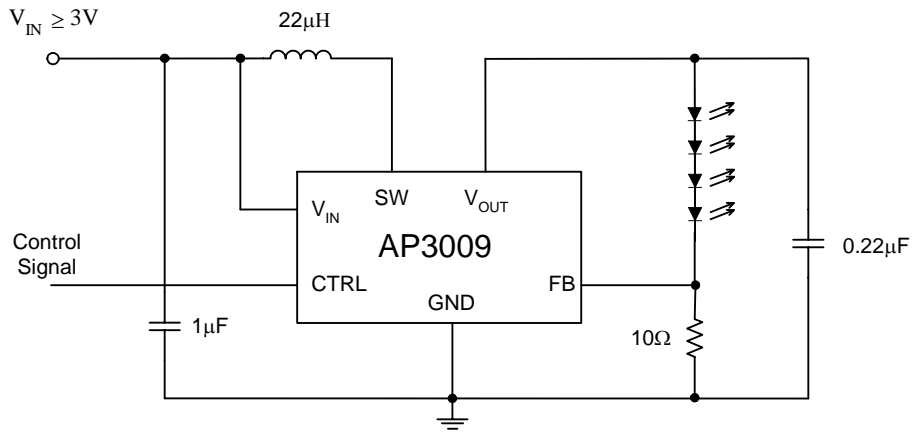

a. Four White LEDs Driver

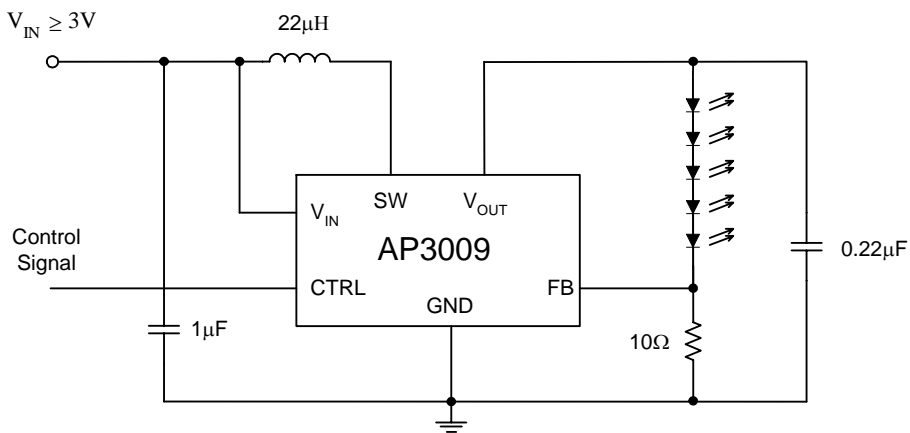

b. Five White LEDs Driver



WHITE LED STEP-UP CONVERTER

AP3009

Typical Application (Continued)

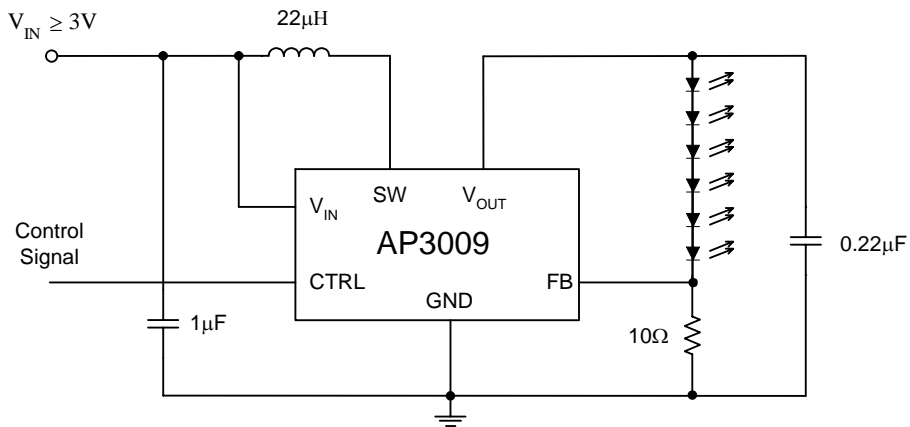

c. Six White LEDs Driver

C: X5R or X7R Dielectric
L: SUMIDA CDRH5D28R-220NC or Equivalent
All these circuits can work in full temperature

Figure 19. Typical White LED Drivers



WHITE LED STEP-UP CONVERTER

AP3009

Mechanical Dimensions

SOT-23-6

Unit: mm(inch)

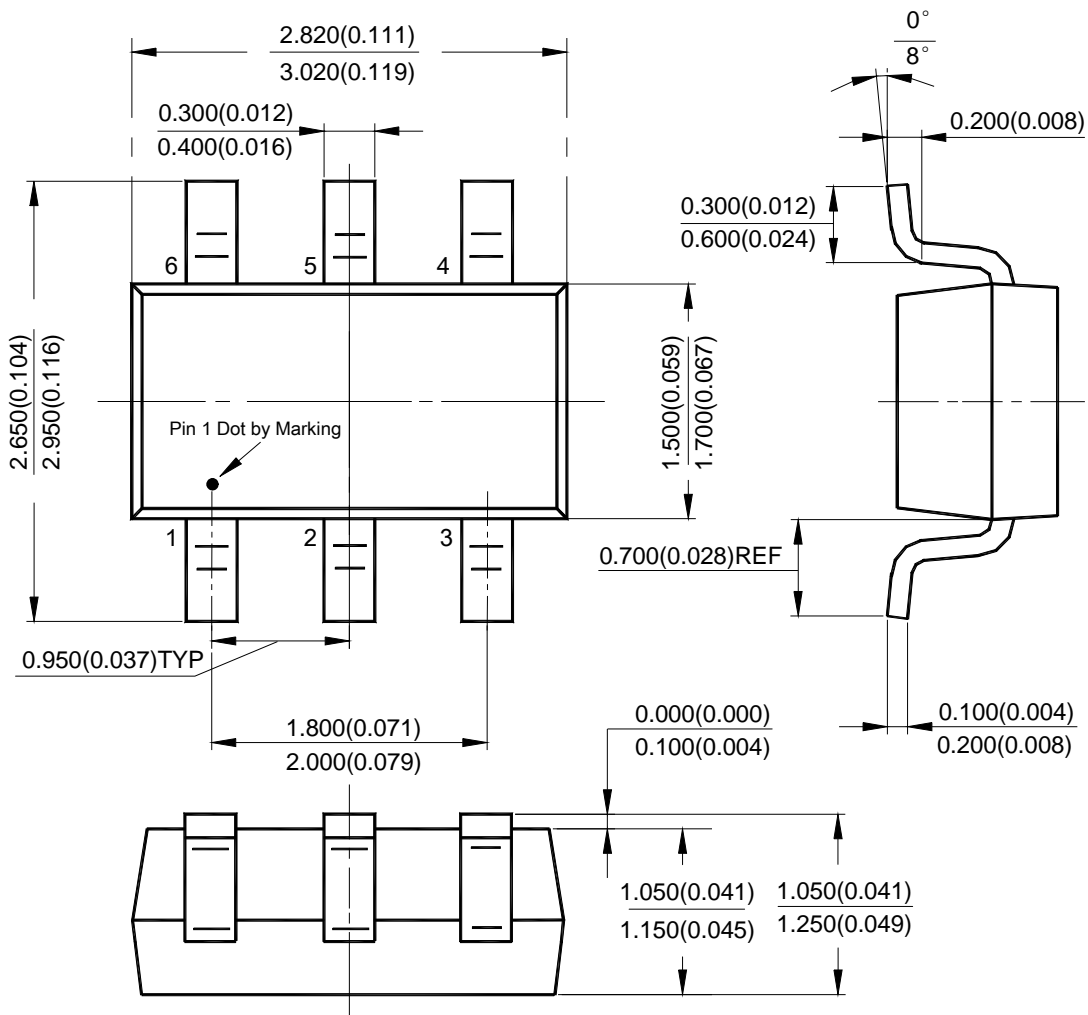



BCD Semiconductor Manufacturing Limited

<http://www.bcdsemi.com>

IMPORTANT NOTICE

BCD Semiconductor Manufacturing Limited reserves the right to make changes without further notice to any products or specifications herein. BCD Semiconductor Manufacturing Limited does not assume any responsibility for use of any its products for any particular purpose, nor does BCD Semiconductor Manufacturing Limited assume any liability arising out of the application or use of any its products or circuits. BCD Semiconductor Manufacturing Limited does not convey any license under its patent rights or other rights nor the rights of others.

MAIN SITE

BCD Semiconductor Manufacturing Limited

- Wafer Fab

Shanghai SIM-BCD Semiconductor Manufacturing Limited

800, Yi Shan Road, Shanghai 200233, China
Tel: +86-21-6485 1491, Fax: +86-21-5450 0008

BCD Semiconductor Manufacturing Limited

- IC Design Group

Advanced Analog Circuits (Shanghai) Corporation

8F Zone B, 900, Yi Shan Road, Shanghai 200233, China
Tel: +86-21-6495 9539, Fax: +86-21-6485 9673

REGIONAL SALES OFFICE

Shenzhen Office

Shanghai SIM-BCD Semiconductor Manufacturing Co., Ltd. Shenzhen Office

Advanced Analog Circuits (Shanghai) Corporation Shenzhen Office
Room E, 5F, Noble Center, No.1006, 3rd Fuzhong Road, Futian District, Shenzhen 518026, China
Tel: +86-755-8826 7951
Fax: +86-755-8826 7865

Taiwan Office

BCD Semiconductor (Taiwan) Company Limited

4F, 298-1, Rui Guang Road, Nei-Hu District, Taipei, Taiwan
Tel: +886-2-2656 2808
Fax: +886-2-2656 2806

USA Office

BCD Semiconductor Corporation

30920 Huntwood Ave. Hayward, CA 94544, U.S.A
Tel: +1-510-324-2988
Fax: +1-510-324-2788