

**WHITE LED STEP-UP CONVERTER****AP3031A****General Description**

The AP3031A is an inductor-based DC/DC boost converter designed to drive LED arrays. 1.2A switching current allows AP3031A to be used in series 10 LEDs application typically.

A constant frequency 1MHz PWM control scheme is employed in this IC, which means tiny external components can be used. Specifically, 1mm tall 22 $\mu$ H inductor and 0.47 $\mu$ F output capacitor for the typical application is sufficient.

The over output voltage protection is equipped in AP3031A, which protects the IC under open load condition. The AP3031A includes UVLO, soft-start, current limit and OTSD to protect the circuit.

The AP3031A is available in standard SOT-23-6 package.

**Features**

- Fast 1MHz Switching Frequency
- Wide Input Voltage Range: 2.7V to 16V
- Low 200mV Feedback Voltage
- Output Over Voltage Protection:36V
- Cycle by Cycle Current Limit: 1.2A
- Built-in Soft-start
- Built-in Standby Mode to Achieve High Frequency PWM Dimming
- Built-in Thermal Shutdown Function
- Under Voltage Lockout

**Applications**

- Digital Photo Frame
- GPS Receiver
- EPC
- PDVD

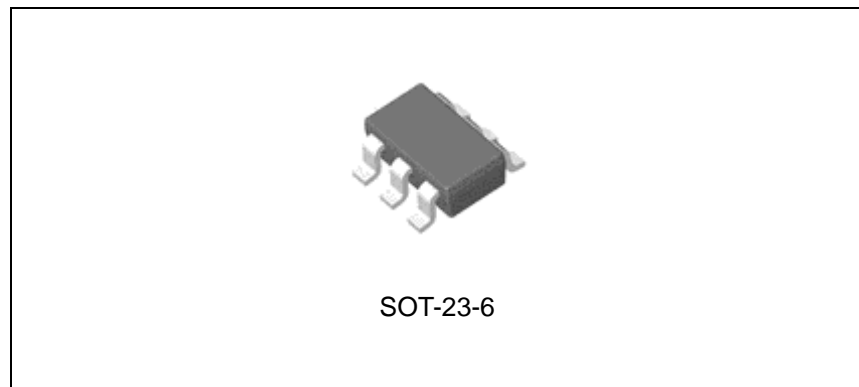

Figure 1. Package Type of AP3031A

**WHITE LED STEP-UP CONVERTER**

**AP3031A**

**Pin Configuration**

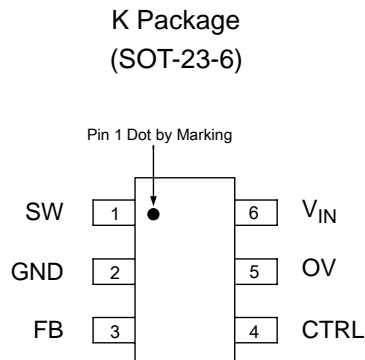

Figure 2. Pin Configuration of AP3031A (Top View)

**Pin Description**

Pin Number	Pin Name	Function
1	SW	Switch Pin. Connect external inductor and Schottky
2	GND	Ground Pin
3	FB	Voltage Feedback Pin. Reference voltage is 200mV
4	CTRL	Enable and Dimming Control Pin. Connect to a high input to enable the IC or a low input to disable the IC. If logic low time is more than about 0.7ms and then enable the IC, the AP3031A will soft start to protect system departments. If logic low time is less than about 0.7ms and then enable the IC, the AP3031A will hold on standby mode and start directly to achieve high frequency dimming
5	OV	Over-voltage Protection Input Pin. Connect to the output directly. On OVP condition, the output voltage will be clamped
6	V <sub>IN</sub>	Input Supply Pin. Must be locally bypassed

**WHITE LED STEP-UP CONVERTER**

**AP3031A**

**Functional Block Diagram**

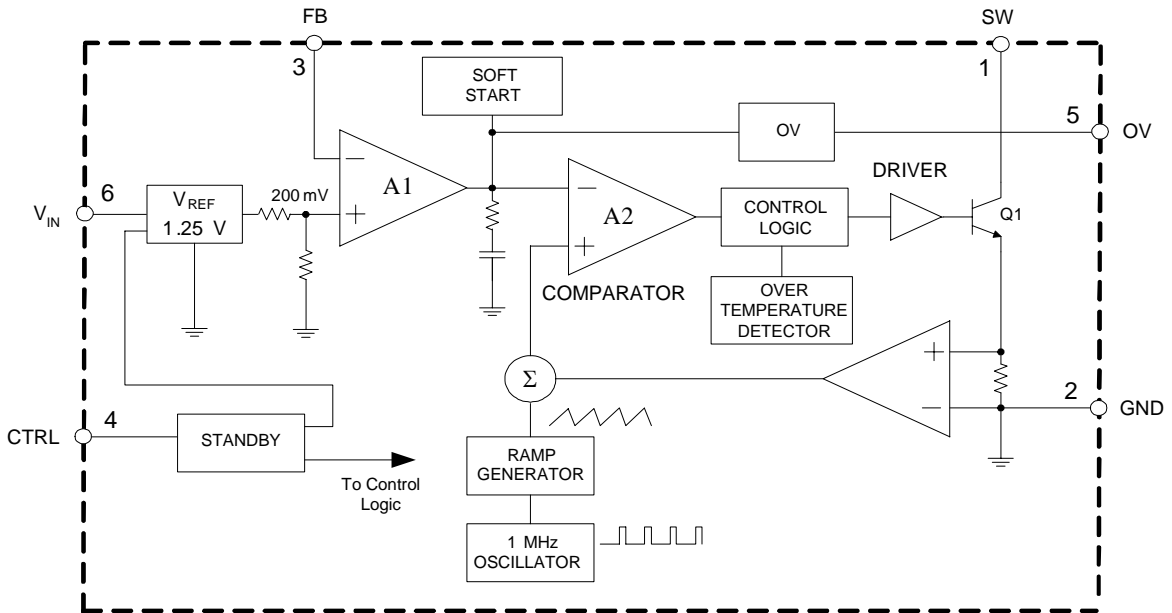
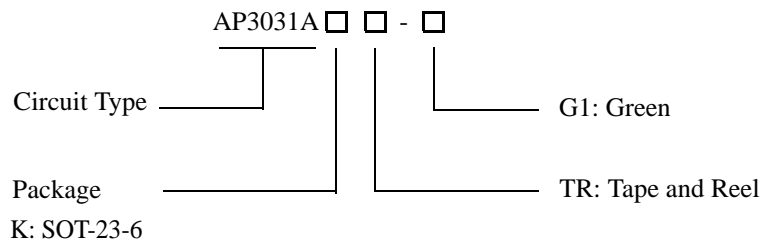

Figure 3. Functional Block Diagram of AP3031A

**Ordering Information**



Package	Temperature Range	Part Number	Marking ID	Packing Type
SOT-23-6	-40 to 85°C	AP3031AKTR-G1	GDH	Tape & Reel

BCD Semiconductor's Pb-free products, as designated with "G1" suffix in the part number, are RoHS compliant and green.

**WHITE LED STEP-UP CONVERTER****AP3031A****Absolute Maximum Ratings (Note 1)**

Parameter	Symbol	Value	Unit
Input Voltage	$V_{IN}$	-0.3 to 20	V
SW Voltage	$V_{SW}$	-0.3 to 38	V
FB Voltage	$V_{FB}$	-0.3 to 20	V
CTRL Voltage	$V_{CTRL}$	-0.3 to $V_{IN}$	V
Thermal Resistance (Junction to Ambient, No Heat Sink)	$\theta_{JA}$	265	$^{\circ}C/W$
Junction Temperature	$T_J$	150	$^{\circ}C$
Storage Temperature Range	$T_{STG}$	-65 to 150	$^{\circ}C$
Lead Temperature (Soldering, 10sec)	$T_{LEAD}$	260	$^{\circ}C$
ESD (Machine Model)		600	V
ESD (Human Body Model)		4000	V

Note 1: Stresses greater than those listed under "Absolute Maximum Ratings" may cause permanent damage to the device. These are stress ratings only, and functional operation of the device at these or any other conditions beyond those indicated under "Recommended Operating Conditions" is not implied. Exposure to "Absolute Maximum Ratings" for extended periods may affect device reliability.

**Recommended Operating Conditions**

Parameter	Symbol	Min	Max	Unit
Operating Temperature Range	$T_{OP}$	-40	85	$^{\circ}C$
Input Voltage	$V_{IN}$	2.7	16	V
CTRL Voltage	$V_{CTRL}$		16	V

**WHITE LED STEP-UP CONVERTER****AP3031A****Electrical Characteristics** $(V_{IN}=5.0V, V_{CTRL}=5.0V, T_A=25^{\circ}C, \text{ unless otherwise specified.})$ 

Parameter	Symbol	Conditions	Min	Typ	Max	Unit
Operating Voltage	$V_{IN}$		2.7		16	V
Feedback Voltage (Note 2)	$V_{FB}$	$I_{OUT}=20mA, T_A=-40^{\circ}C \text{ to } 85^{\circ}C$	<b>188</b>	<b>200</b>	<b>212</b>	mV
FB Pin Bias Current	$I_{FB}$			35	100	nA
Quiescent Current	$I_Q$	$V_{FB}=V_{IN}, \text{ no switching}$	1.5	3.0	5.0	mA
Shutdown Quiescent Current	$I_{SHDN}$	$V_{CTRL}=0V$	20	50	80	$\mu A$
Switching Frequency	f		0.75	1	1.3	MHz
Maximum Duty Cycle	$D_{MAX}$		90	93		%
Switch Current Limit	$I_{LIMIT}$	D=60%	1.0	1.2		A
Switch $V_{CE}$ Saturation Voltage	$V_{CESAT}$	$I_{SW}=0.6A$		300		mV
Switch Leakage Current		$V_{SW}=35V$		0.01	5	$\mu A$
CTRL Pin Voltage	$V_{CTRL}$	Active high	1.8			V
		Active low			0.5	
CTRL Pin Bias Current	$I_{CTRL}$		40	55	72	$\mu A$
OVP Voltage	$V_{OVP}$			36		V
Soft-start Time	$t_{SS}$			300		$\mu s$
Standby Time	$t_{STB}$			0.7		ms
Thermal Shutdown	$T_{OTSD}$			160		$^{\circ}C$

Note 2: The bold type specifications of full temperature range are guaranteed by design (GBD).



**WHITE LED STEP-UP CONVERTER**

**AP3031A**

**Typical Performance Characteristics**

(WLED forward voltage ( $V_F$ )=3.2V at  $I_F$ =20mA, unless otherwise noted.)

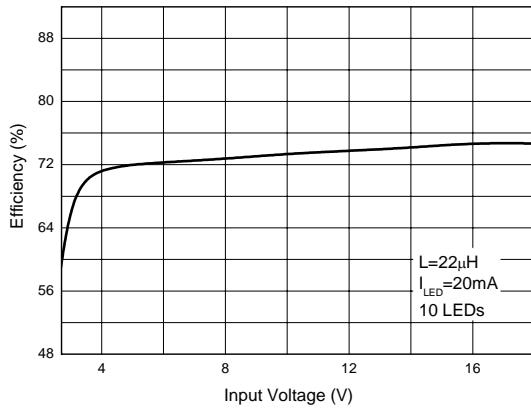

Figure 4. Efficiency vs. Input Voltage

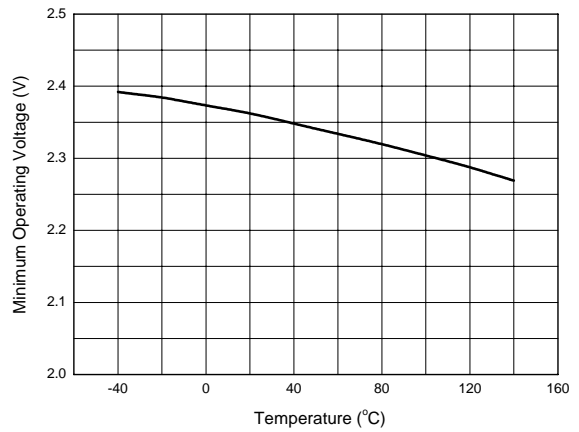

Figure 5. Minimum Operating Voltage vs. Temperature

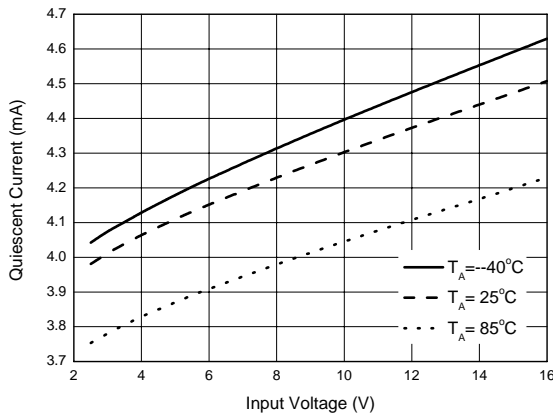

Figure 6. Quiescent Current vs. Input Voltage

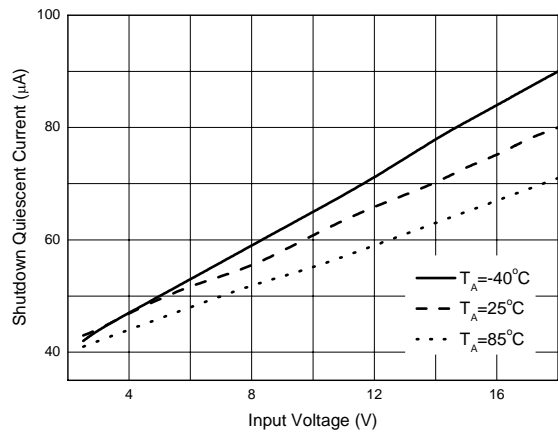

Figure 7. Shutdown Quiescent Current vs. Input Voltage



**WHITE LED STEP-UP CONVERTER**

**AP3031A**

**Typical Performance Characteristics (Continued)**

(WLED forward voltage ( $V_F$ )=3.2V at  $I_F$ =20mA, unless otherwise noted.)

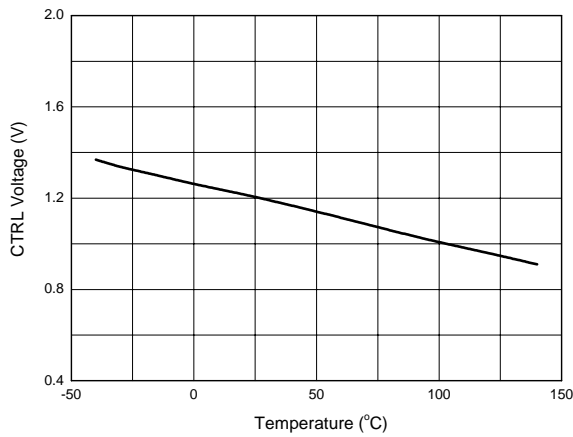

Figure 8. CTRL Pin Voltage vs. Temperature

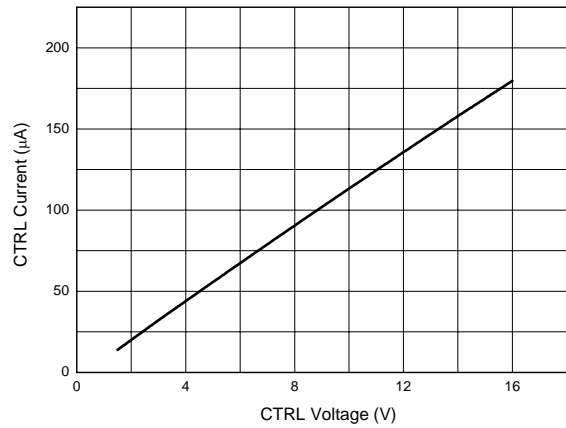

Figure 9. CTRL Current vs. CTRL Voltage

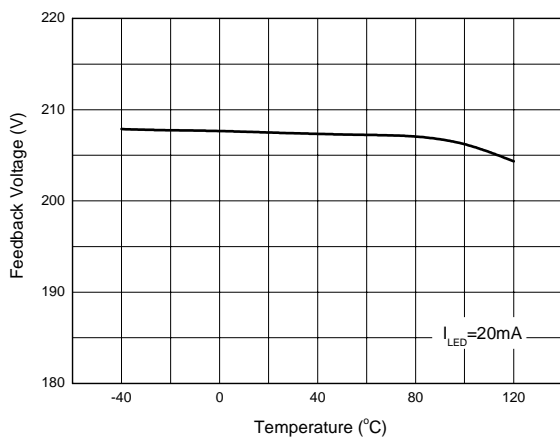

Figure 10. Feedback Voltage vs. Temperature

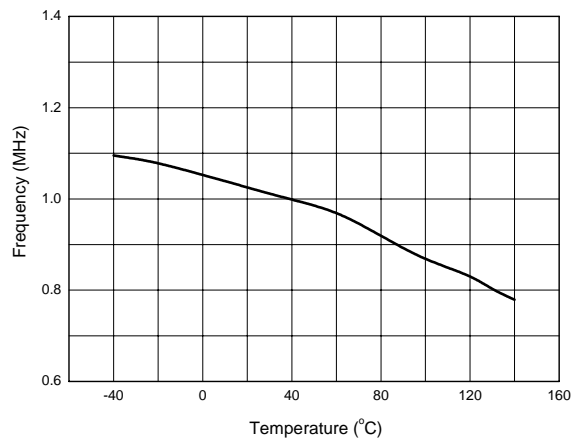

Figure 11. Frequency vs. Temperature



**WHITE LED STEP-UP CONVERTER**

**AP3031A**

**Typical Performance Characteristics (Continued)**

(WLED forward voltage ( $V_F$ )=3.2V at  $I_F$ =20mA, unless otherwise noted.)

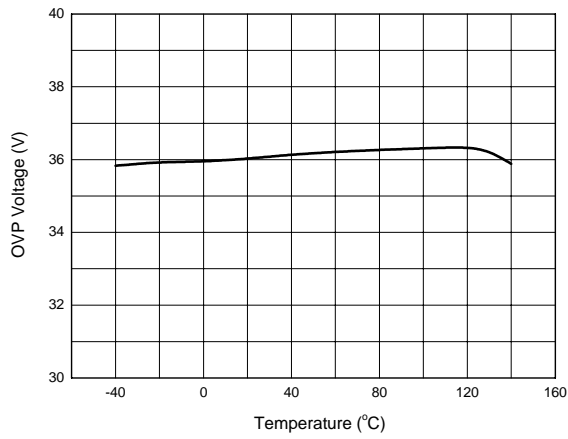

Figure 12. OVP Voltage vs. Temperature

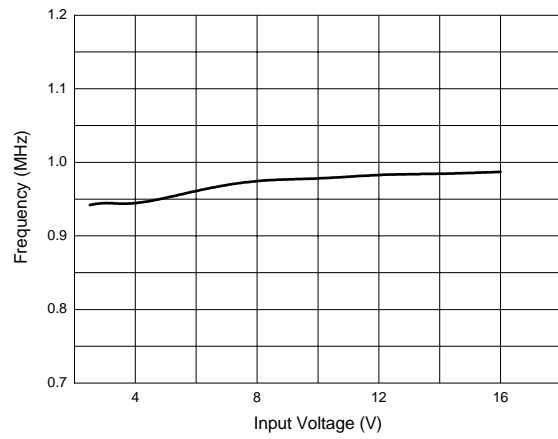

Figure 13. Frequency vs. Input Voltage

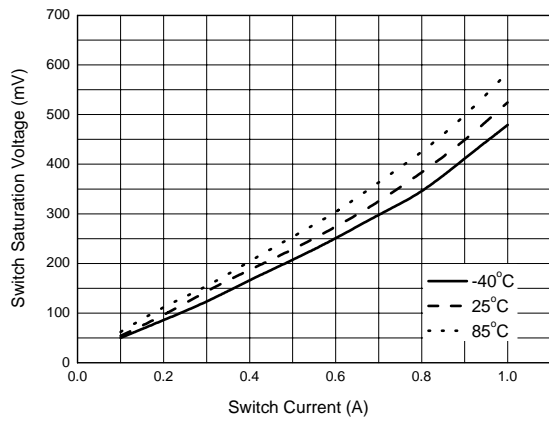

Figure 14. Switch Saturation Voltage vs. Switch Current

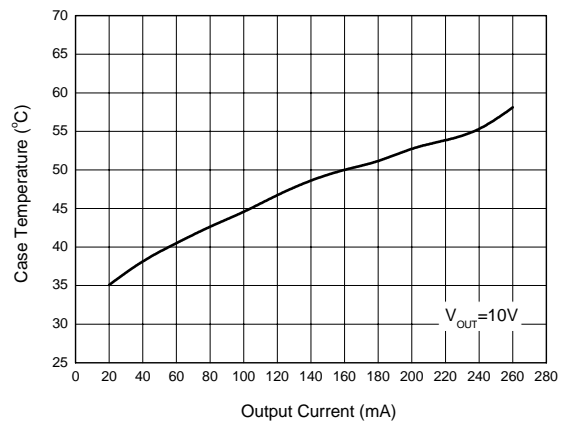

Figure 15. Case Temperature vs. Output Current



**WHITE LED STEP-UP CONVERTER**

**AP3031A**

**Typical Application**

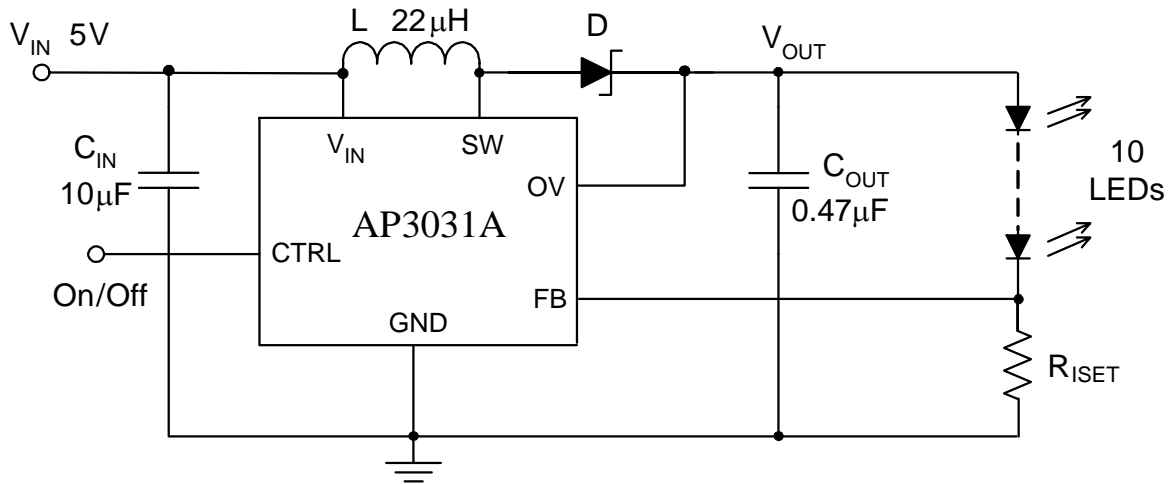

Figure 16. Typical Application of AP3031A (10 WLEDs Series)



**WHITE LED STEP-UP CONVERTER**

**AP3031A**

**Mechanical Dimensions**

**SOT-23-6**

**Unit: mm(inch)**

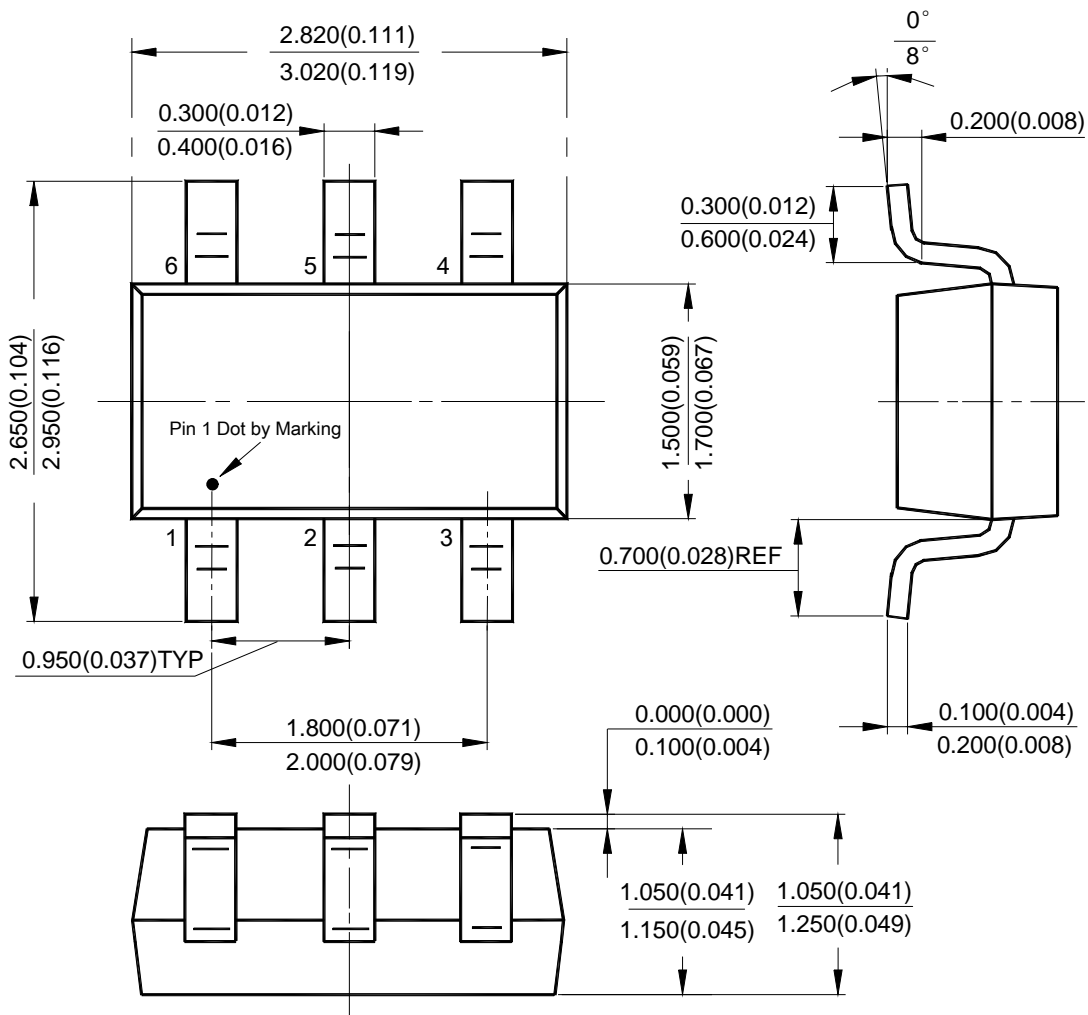



## **BCD Semiconductor Manufacturing Limited**

<http://www.bcdsemi.com>

### **IMPORTANT NOTICE**

BCD Semiconductor Manufacturing Limited reserves the right to make changes without further notice to any products or specifications herein. BCD Semiconductor Manufacturing Limited does not assume any responsibility for use of any its products for any particular purpose, nor does BCD Semiconductor Manufacturing Limited assume any liability arising out of the application or use of any its products or circuits. BCD Semiconductor Manufacturing Limited does not convey any license under its patent rights or other rights nor the rights of others.

---

#### **MAIN SITE**

##### **- Headquarters**

##### **BCD Semiconductor Manufacturing Limited**

No. 1600, Zi Xing Road, Shanghai Zizhu Science-based Industrial Park, 200241, China  
Tel: +86-21-24162266, Fax: +86-21-24162277

##### **- Wafer Fab**

##### **Shanghai SIM-BCD Semiconductor Manufacturing Co., Ltd.**

800 Yi Shan Road, Shanghai 200233, China  
Tel: +86-21-6485 1491, Fax: +86-21-5450 0008

#### **REGIONAL SALES OFFICE**

##### **Shenzhen Office**

**Shanghai SIM-BCD Semiconductor Manufacturing Co., Ltd., Shenzhen Office**  
Room E, 5F, Noble Center, No.1006, 3rd Fuzhong Road, Futian District, Shenzhen,  
518026, China  
Tel: +86-755-8826 7951  
Fax: +86-755-8826 7865

##### **Taiwan Office**

**BCD Semiconductor (Taiwan) Company Limited**  
4F, 298-1, Rui Guang Road, Nei-Hu District, Taipei,  
Taiwan  
Tel: +886-2-2656 2808  
Fax: +886-2-2656 2806

##### **USA Office**

**BCD Semiconductor Corp.**  
30920 Huntwood Ave. Hayward,  
CA 94544, USA  
Tel : +1-510-324-2988  
Fax: +1-510-324-2788