

TruBass Audio Enhancement Processor

1 Overview

The **AP8111** is a bass enhancement processor based on SRS Labs, Inc.'s patented TruBass technology. TruBass is a revolutionary psychoacoustic bass enhancement technology that provides deep, rich bass to small speakers without the need for a subwoofer or additional extra physical components. Deep bass now becomes possible even through speakers with limitations in driver and cabinet design. TruBass circuitry actively monitors the low-frequency content of an audio signal and optimizes the frequency and amplitude spectrum of the output signal to enhance bass perception. For systems with a subwoofer, TruBass complements and enhances bass performance.

TruBass is therefore most suitable for applications that use small size speakers yet need to deliver the best audio quality or home theatre effect: Mini or Micro Stereo Sound Systems, TV, CD, Boombox, Car Audio, DVD Receiver, Set-Top-Box, and other compact hi-fi systems such as Discman, MD, MP3 player, as well as PCs.

2 Features

- Operating Voltage 4.75V to 5.25V
- Low Operation Current 10mA typ
- Power down and Bypass mode selection
- Analog switch for mode and gain control
- External adjustment for speaker size setting (small, medium and large)
- Bipolar Technology
- Chip Package 28 pins SOP

The TruBass technology rights in the **AP8111** are owned by SRS Labs, a United States Corporation and licensed to ASP Microelectronics Ltd. TruBass is protected under US and foreign patents issues and/or pending. TruBass and the  symbol are trademarks of SRS Labs, Inc. in the United State and selected foreign countries. Neither the purchase of the **AP8111**, nor the corresponding sale of audio enhancement equipment conveys the right to sell commercialized recordings made with any SRS technology. SRS Labs requires all set makers to comply with all rules and regulations as outlined in the SRS Trademark Usage Manual separately provided.

For further information, please contact:

SRS Labs, Inc.

2909 Daimler Street, Santa Ana, CA 92705 USA

Tel: 949-442-1070

Fax: 949-852-1099

<http://www.srslabs.com>

ASP Microelectronics Ltd.
Unit 218, 2/F., Tech Centre,
72 Tat Chee Ave., Kowloon Tong, Hong Kong
Tel: (852) 2797 3288 Fax: (852) 2797 3112
<http://www.asp.com.hk>

[CAUTION]

The information in this publication is believed to be accurate in all respects at the time of publication but is subject to change without notice. ASP Microelectronics Ltd. assumes no responsibility for errors and omissions, and disclaims responsibility for any consequences resulting from the use of information included herein. Additionally, ASP Microelectronics Ltd. assumes no responsibility for the functioning of undocumented features or parameters.

3 Device Pin Out and Pin Descriptions

Pin #	Pin Name	Type	Descriptions
1	LOUT	AOUT	Left channel audio line output
2	LIN	AIN	Left channel audio line input
3	VREF	AOUT	2.25V analog reference
4	NC	-	Not used
5	CB1A	AI/O	100Hz band-pass filter circuit
6	CB1B	AI/O	100Hz band-pass filter circuit
7	CB1	AI/O	100Hz band-pass filter circuit
8	GND	PWR	Analog ground
9	TBGAIN	DIN	TruBass gain control. +6dB gain when this pin short to ground.
10	CB2B	AI/O	40/150Hz band-pass filter circuit
11	CB2A	AI/O	40/150Hz band-pass filter circuit
12	CB2	AI/O	40/150Hz band-pass filter circuit
13	BYPASS	DIN	Power down/ Bypass / TruBass-enable selection
14	COMPI	AIN	Compressor input
15	CL1	AI/O	Low-pass filter capacitor
16	FOUT	AOUT	Filter output
17	COMPC2	AI/O	Compressor capacitor
18	NC	-	Not used.
19	VCC	PWR	5 volts power supply
20	COMPC1	AI/O	Compressor output
21	CB3B	AI/O	60/200Hz band-pass filter circuit
22	CB3A	AI/O	60/200Hz band-pass filter circuit
23	CB3	AI/O	60/200Hz band-pass filter circuit
24	CL2B	AI/O	Low-pass filter capacitor
25	NC	-	Not used
26	CL2A	AI/O	Low-pass filter capacitor
27	RIN	AIN	Right channel audio line input
28	ROUT	AOUT	Right channel audio line output

AOUT - analog output pin
 AIN - analog input pin
 AI/O - analog bi-directional pin
 DIN - digital input pin
 PWR - power pin

4 Pin Configuration

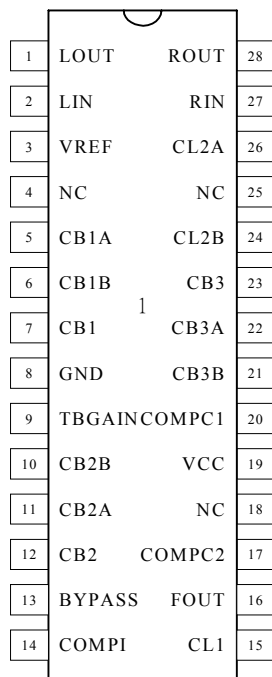

5 Operating Modes

The chip can be configured in 3 modes of operations – Power down mode, bypass mode, TruBass mode.

In power down mode, the chip is power down and consumed minimal current.

In bypass mode, line in audio signal is pass directly to the output.

In TruBass mode, line in audio signal is enhanced with the TruBass algorithm.

The **Bypass** pin (pin 11) is used to select the operating mode. When the pin is forced to 0v, the chip is powered down and when the pin is at float (or Vcc/2) and at 5v, the mode is set to Bypass and TruBass Enabled respectively.

An additional +6dB gain is enabled by pulling the pin TBGAIN to ground.

6 Speaker Size and Filter Center Frequencies selection

The configuration of the TruBass band-pass filters depends on the speaker size for the system. There are three configurations: small, medium and large. Each configuration uses three bandpass filters, but with different center frequencies for the filters as follows:

Speaker Size	Filter Center Frequencies
Small	100Hz
Medium	60Hz
Large	40Hz

The low pass filter cutoff frequency and the band pass filter center frequencies can be adjusted to match the frequency response of the speakers being used. Generally, the speaker size setting should be selected so that the lowest of the band pass center frequencies is just above the low cutoff frequency of the speaker system.

All configurations require the 100Hz filter, so its center frequency is fixed. The center frequencies of the other two filters are configured by the external resistors placed on pins CB2, CB2A, CB2B, CB3, CB3A, CB3B.

7 Application circuit

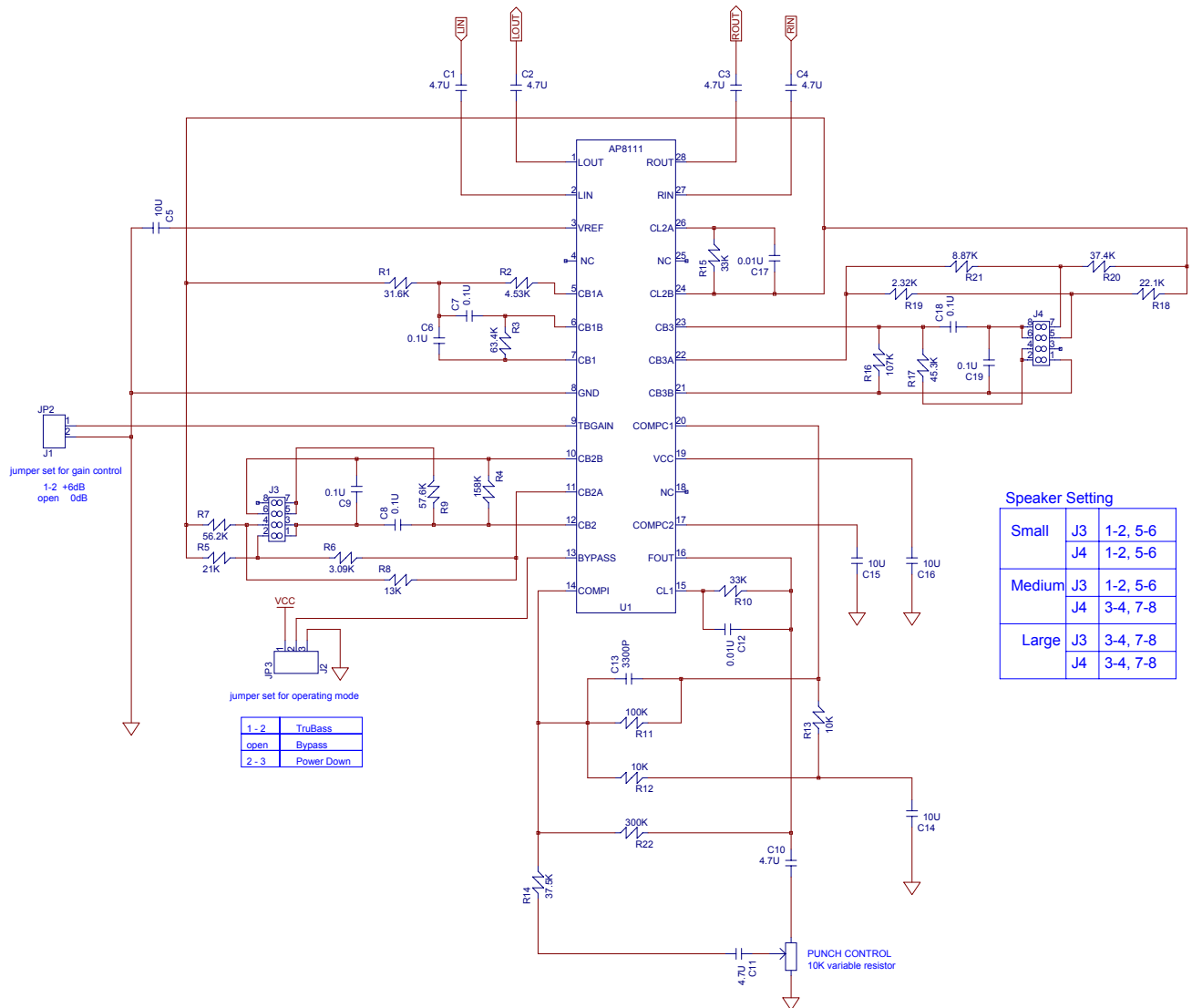

Tolerance all resistors are $\pm 1\%$, capacitors are $\pm 10\%$

8 Recommended Operating Condition

The following is the recommended operating conditions for the TruBass analog processor

Symbol	Parameter	Min	Max	Unit
VCC	DC supply voltage	4.75	5.25	Volts
Vi	DC input voltage range	-0.3	VCC+0.3	Volts
Vo	DC output voltage range	0	VCC	Volts
Tamb	Operating ambient temperature range	0	70	°C

9 DC Electrical Specifications

Symbol	Parameter	Conditions	Min	Typ	Max	Units
Vcc	Chip supply voltage		4.75	5	5.25	V
Icc	Operating current	Vcc = 5.0		10		mA
Ipd	Power down supply current	Vcc = 5.0		25	50	uA
Rin	Left/Right input impedance		10			kΩ
Vref	Analog reference voltage		2.02	2.25	2.48	V
Rload	Resistance load at Left/Right output		10			kΩ
Cload	Capacitance load at Left/Right output				50	pF
Vil	Digital input logic low				0.3	V
Vmid	Mid-level for Tri-level logic	If floated, internal reference will ensure Vmid	Vcc/2 – 10%	Vcc/2	Vcc/2 + 10%	V
Vih	Digital input logic high		Vcc – 0.3			V
Ileak	Digital input leakage (except TBGAIN)	Vcc = 5.0	-10		10	uA

10 AC Electrical Specifications

Symbol	Parameter	Conditions	Min	Typ	Max	Units
Freq	Audio signal operating frequency		20		20000	Hz
Vrli	Audio input signal level (0dB level reference)	Inputs AC coupled			1	Vrms
Vrlo	Audio output level	Rload = 10kΩ			1	Vrms
Gerror	Output gain error	Bypass mode, input signal @ 0dB 1kHz	-0.5		0.5	dB
SNR	Signal to noise ratio	Bypass mode /A-weighted, input signal @ -60dB 1kHz	80			dB
THD	Total harmonic distortion	Bypass mode Input @ 0dB 1kHz			1	%
Xtalk	Channel Crosstalk	Bypass mode			-70	dB
Comp	TruBass Compressor Ratio	Punch at maximum gain		2:1		
Rate	Attack to decay time constant ratio	Absolute value set by external capacitor		10:1		

REV.	DESCRIPTION	DATE	ENG	APPROVAL
—	GENERATE. PLACE IN SPEC CENTER AS PER ECN—			

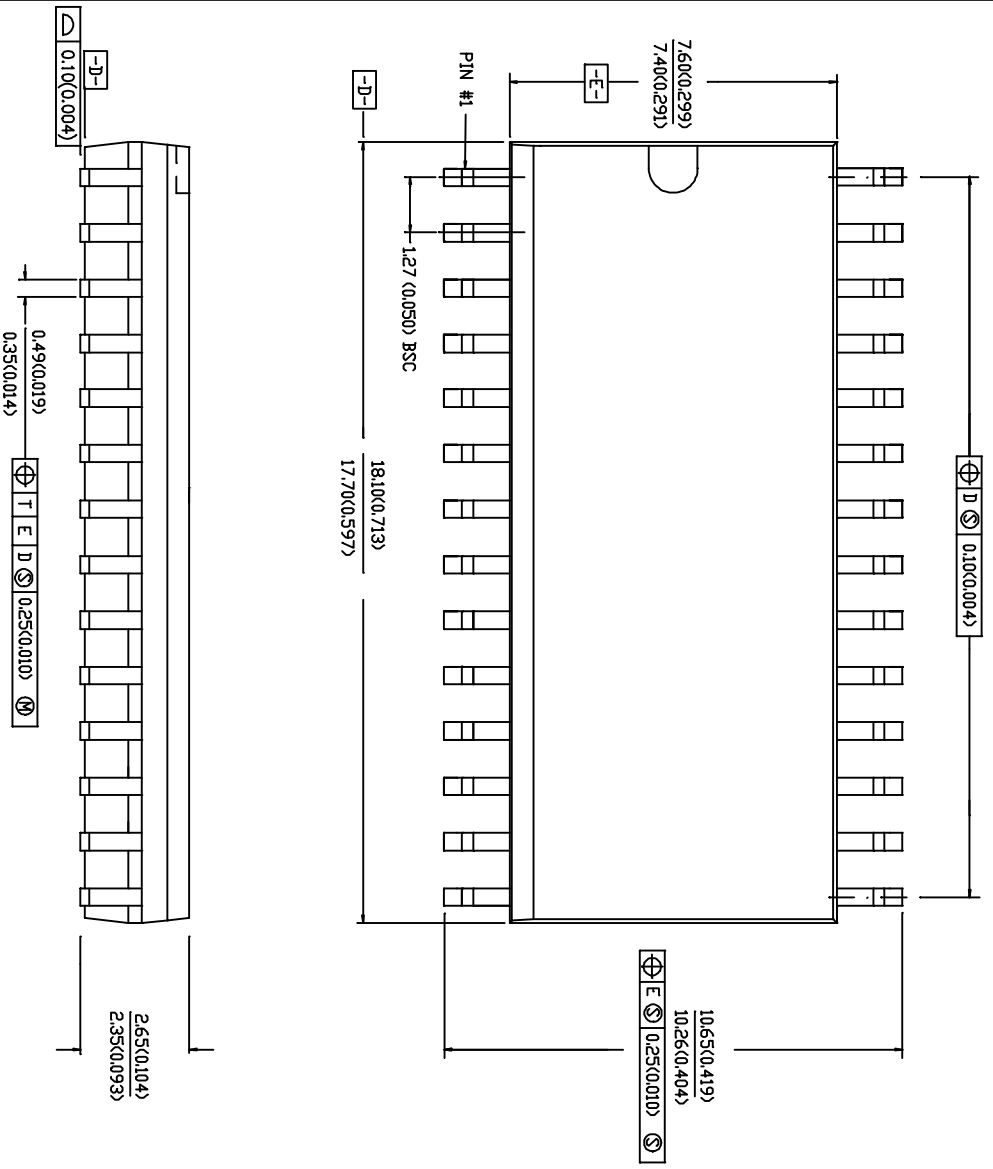

NOTES

- Package dimensions conform to JEDEC Specification MS-013-AE for Standard Small Outline (SO) package, 28 leads, 7.50mm (0.300") body width (Issue A, June 1985).
- Controlling dimensions are mm. Inch dimensions in parentheses.
- Dimensioning and tolerancing per ANSI Y 14.5M - 1982.
- "D" and "E" are reference datums on the molded body and do not include mold flash/protrusions. Mold flash/protrusions at "D" shall not exceed 0.15mm (0.006") per side. Inter-lead flash/protrusions at "E" shall not exceed 0.25mm (0.010") per side.
- The lead width above the seating plane shall not exceed a maximum value of 0.61mm (0.024").
- Pin numbers start with Pin #1 and continue counterclockwise to pin #28 when viewed from top.

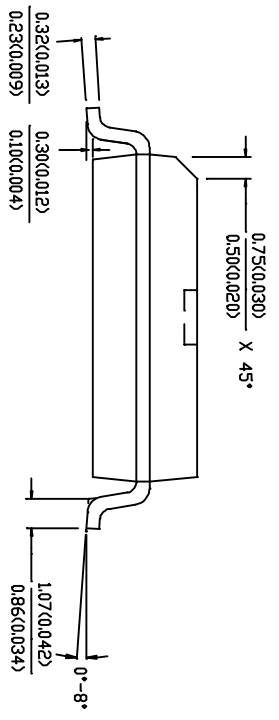

LIST OF MATERIAL AND APPLICABLE DOCUMENTS

SCALE:	NONE	DATE:	11/15/95	DRAWN:	TITLE:
DIMENSIONAL UNIT:	MM (INCH)	UNTOLENCED DIMENSIONS:	FRACTIONAL	ENGINEER:	28 LEAD SMALL OUTLINE PLASTIC .300" BODY WIDTH
PROJECTION UNLESS SPECIFIED:		ANGLE:	XXXX	CHECKED:	
				APPROVED:	
				OLD NAME:	OSO-30028
				DRAWING NUMBER:	OSO-30028
				REV:	1 OF 1