

Direct PWM Variable Speed Fan Motor Driver

Features

- **Single Phase Full Wave Fan Driver**
- **Low Quiescent Current (6mA Typical)**
- **Built-in Variable Speed Function**
- **Current Limit Circuit (includes both internal and external Current Limit)**
- **Built-in Lock Protection and Auto Restart Function**
- **FG (rotation speed detection) Output**
- **Soft Switching Circuit (before phase change, enabling low-consumption, low loss and low noise drive.)**
- **Over Voltage Protection (16.5V Typical)**
- **Built-in Kickback Absorption Circuit**
- **Built-in Thermal Protection Circuit**
- **Lead Free and Green Devices Available (RoHS Compliant)**



General Description

The APX9270 is a single phase, DC brushless motor driver with PWM variable speed control and current limit features suitable for the fan of personal computer's power supply and CPU cooler. The PWM control system includes thermistor input signal and direct PWM input signal, enabling highly silent and low vibration speed control. The device is equipped with a built-in lock protection, which protects the fan when it is locked. It also has rotation speed detection output and thermal protection function. The APX9270 is available in SSOP-20 and TSSOP-20P packages (see Pin Configurations).

Applications

- **CPU Coolers**
- **Variable Speed Control Fans**

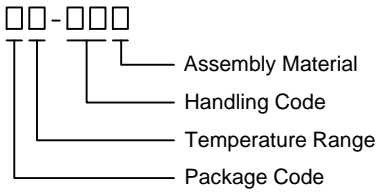
Ordering and Marking Information

| | |
|---|--|
| <p>APX9270 □□-□□□</p>  <p>Assembly Material Handling Code Temperature Range Package Code</p> | <p>Package Code N : SSOP-20 R: TSSOP-20P Operating Ambient Temperature Range I : -40 to 90 °C Handling Code TR : Tape & Reel Assembly Material L : Lead Free Device G : Halogen and Lead Free Device</p> |
| <p>APX9270 N/R : </p> | <p>XXXXX - Date Code</p> |

Note: ANPEC lead-free products contain molding compounds/die attach materials and 100% matte tin plate termination finish; which are fully compliant with RoHS. ANPEC lead-free products meet or exceed the lead-free requirements of IPC/JEDEC J-STD-020C for MSL classification at lead-free peak reflow temperature. ANPEC defines "Green" to mean lead-free (RoHS compliant) and halogen free (Br or Cl does not exceed 900ppm by weight in homogeneous material and total of Br and Cl does not exceed 1500ppm by weight).

Pin Configurations

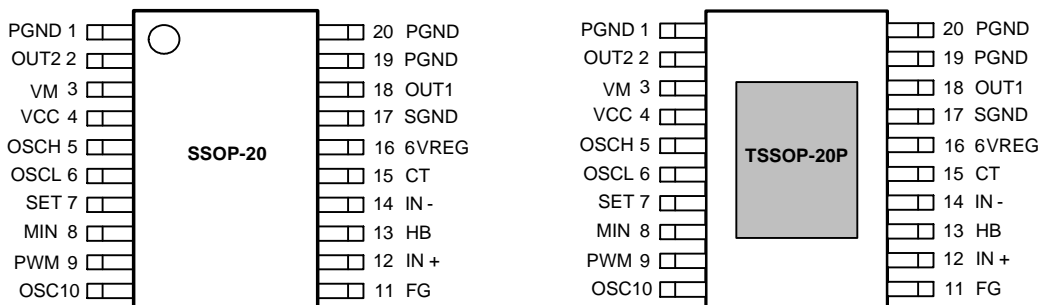

ANPEC reserves the right to make changes to improve reliability or manufacturability without notice, and advise customers to obtain the latest version of relevant information to verify before placing orders.

Absolute Maximum Ratings

| Symbol | Parameter | Ratings | Unit |
|---------------------|---|-------------------------|------|
| V_{CC} | VCC Pin Supply Voltage (VCC to SGND) | -0.3 to 18 | V |
| V_M | VM Pin Supply Voltage (VM to SGND) | -0.3 to V_{CC} | V |
| I_{OUT} | OUT1/OUT2 Pin Maximum Output Current | 1.2 | A |
| V_{OUT1}/V_{OUT2} | OUT1/OUT2 Pin Output Voltage (OUT1, OUT2 to SGND) | $V_{PGND}-0.3$ to V_M | V |
| V_{PGND} | PGND to SGND Voltage | -0.3 to 0.3 | V |
| I_{HB} | HB Pin Output Current | 0 to 15 | mA |
| V_{SET} | SET Pin Input Voltage (SET to SGND) | -0.3 to 7 | V |
| V_{MIN} | MIN Pin Input Voltage (MIN to SGND) | -0.3 to 7 | V |
| V_{PWM} | PWM Pin Input Voltage (PWM to SGND) | -0.3 to V_{CC} | V |
| V_{FG} | FG Pin Output Voltage (FG to SGND) | -0.3 to V_{CC} | V |
| I_{FG} | FG Pin Output Current | 0 to 10 | mA |
| V_{OSC} | OSC Pin Input Voltage (OSC to SGND) | -0.3 to 7 | V |
| V_{CT} | CT Pin Input Voltage (CT to SGND) | -0.3 to 7 | V |
| P_D | Power Dissipation SSOP-20 TSSOP-20P | 1.2 | W |
| | | 1.5 | |
| T_J | Maximum Junction Temperature | 150 | °C |
| T_{STG} | Storage Temperature Range | -55 to 150 | °C |
| T_{SDR} | Maximum Lead Soldering Temperature, 10 Seconds | 260 | °C |

Note 1: Stresses above those listed in "Absolute Maximum Ratings" may cause permanent damage to the device.

Thermal Characteristics

| Symbol | Parameter | Value | Unit |
|-------------|--|-------|------|
| $R_{TH,JA}$ | Thermal Resistance-Junction to Ambient SSOP-20 TSSOP-20P | 104 | °C/W |
| | | 83 | |
| | | | |

Note 2: Mounted on a board (60x38x1.6t mm, Glass epoxy).

Recommended Operating Conditions

| Symbol | Parameter | Rating | Unit |
|---------------------|---|---------------|------|
| V_{CC} | VCC Pin Supply Voltage | 4.5 to 15 | V |
| V_M | VM Pin Supply Voltage | 3.5 to 15 | V |
| V_{SET} | SET Pin Input Voltage Range | 0 to 6 | V |
| V_{MIN} | MIN Pin Input Voltage Range | 0 to 6 | V |
| V_{PWM} | PWM Pin Input Voltage Range | 0 to V_{CC} | V |
| V_{OSCH}/V_{OSCL} | OSC High/Low Level Input Voltage Range | 0 to 6 | V |
| V_{ICM} | Hall Input Common Phase Input Voltage Range | 0.2 to 3 | V |
| T_A | Ambient Temperature | -40 to 90 | °C |

Electrical Characteristics ($V_{CC} = 12V$, $T_A = 25^\circ C$, $R_L = 0\Omega$, unless otherwise specified)

| Symbol | Parameter | Test Conditions | APX9270 | | | Unit |
|--------------------------------|-----------------------------------|--|---------|------|-------|------------|
| | | | Min. | Typ. | Max. | |
| SUPPLY CURRENT | | | | | | |
| V_{6VREG} | 6VREG Pin Output Voltage | $I_{6VREG} = 5mA$ | 5.85 | 6 | 6.15 | V |
| V_{HB} | HB Pin Output Voltage | $I_{HB} = 5mA$ | 1.2 | 1.3 | 1.4 | V |
| I_{CC1} | Operating Current | Rotation Mode | - | 6 | 8 | mA |
| I_{CC2} | | Lock Protection Mode | - | 6 | 8 | mA |
| OSCILLATOR | | | | | | |
| I_{OSC1} | OSC Charge Current | | 7.5 | 10 | 12.5 | μA |
| I_{OSC2} | OSC Discharge Current | | 7.5 | 10 | 12.5 | μA |
| LOCK PROTECTION | | | | | | |
| V_{CTH} | CT Pin High Level Voltage | $C_{CT} = 1\mu F$ | 3.4 | 3.6 | 3.8 | V |
| V_{CTL} | CT Pin Low Level Voltage | $C_{CT} = 1\mu F$ | 1.4 | 1.6 | 1.8 | V |
| I_{CT1} | CT Charge Current | $V_{CT} = 0V$ | 1.65 | 2.2 | 2.75 | μA |
| I_{CT2} | CT Discharge Current | $V_{CT} = 3.6V$ | 0.165 | 0.22 | 0.275 | μA |
| R_{CT} | CT Charge/Discharge Current Ratio | $R_{CT} = I_{CT1}/I_{CT2}$ | 8 | 10 | 12 | - |
| OUTPUT DRIVERS | | | | | | |
| V_{OL} | Output Lower Side Saturation | $I_{OUT} = 400mA$ | - | 0.2 | 0.3 | V |
| V_{OH} | Output Upper Side Saturation | $I_{OUT} = 400mA$ | - | 0.4 | 0.6 | V |
| V_{FG} | FG Pin Low Voltage | $I_{FG} = 5mA$ | - | 0.2 | 0.4 | V |
| I_{FGL} | FG Pin Leak Current | $V_{FG} = 7V$ | - | 0.1 | 1 | μA |
| HALL SENSITIVITY | | | | | | |
| V_{HN} | Hall Input Sensitivity | Zero to peak including offset and hysteresis | - | 25 | 35 | mV |
| CURRENT-LIMIT | | | | | | |
| I_{LIM} | Internal Current-Limit | | - | 1200 | - | mA |
| I_{RL} | External Current-Limit | $R_L = 0.5\Omega$ | - | 960 | - | mA |
| THERMAL PROTECTION | | | | | | |
| | Thermal Protection Temperature | | - | 160 | - | $^\circ C$ |
| | Thermal Protection Hysteresis | | - | 20 | - | |
| Over-Voltage Protection | | | | | | |
| V_{OV} | Over-Voltage Threshold | | - | 16.5 | - | V |

Typical Operating Characteristics

VCC Supply Current vs. VCC Supply Voltage

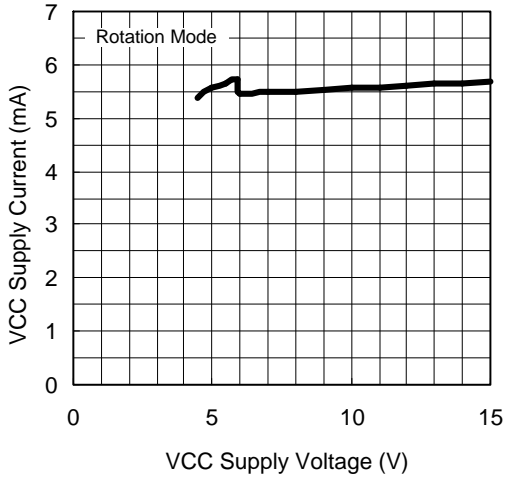

VCC Supply Current vs. VCC Supply Voltage

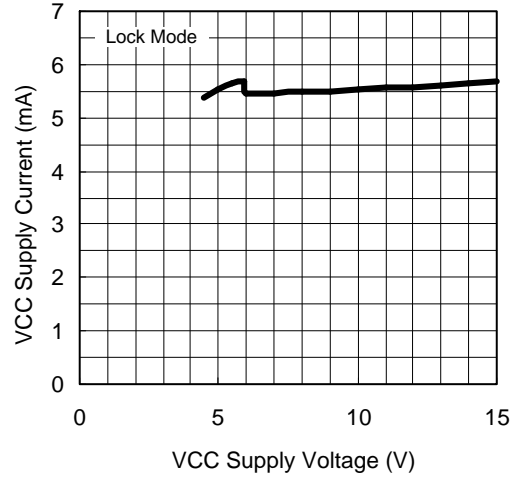

OSC Charge/Discharge Current vs. VCC Supply Voltage

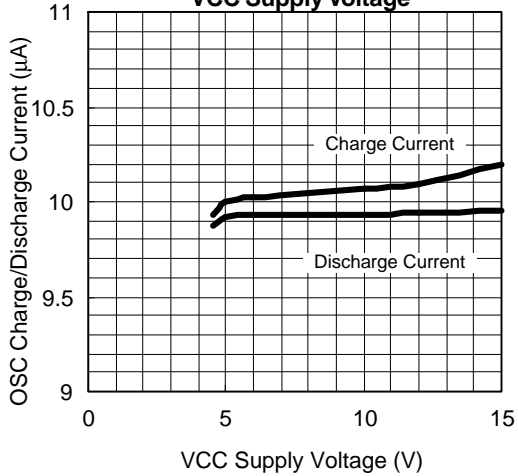

CT Charge/Discharge Current vs. VCC Supply Voltage

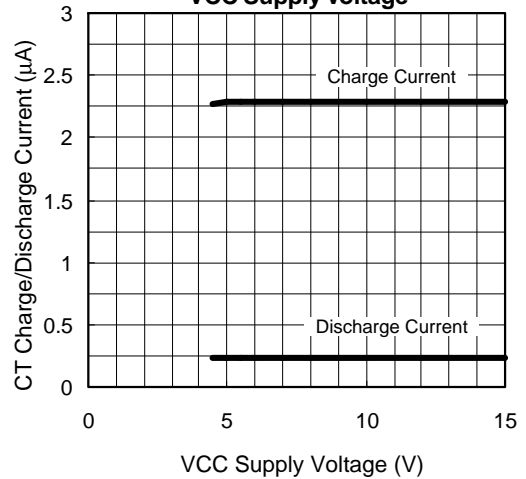

Output Saturation Voltage vs. Output Current

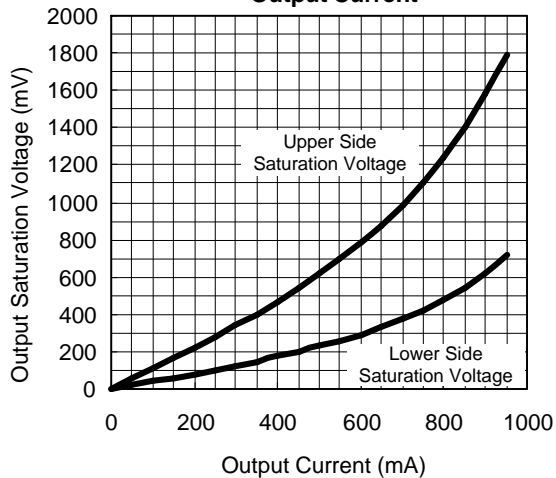

FG Pin Low Voltage vs. Sink Current

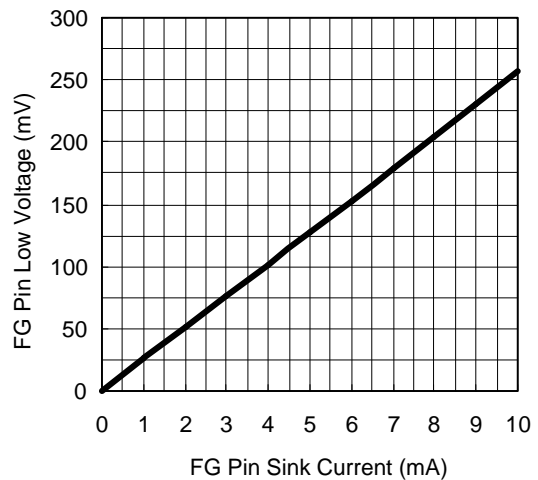

Typical Operating Characteristics

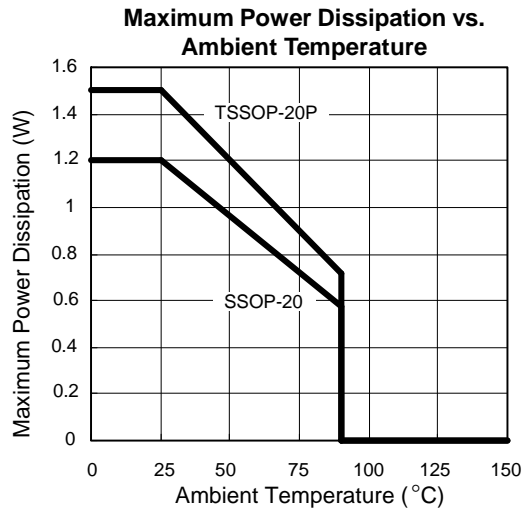

Operating Waveforms

Rotation Waveform 1

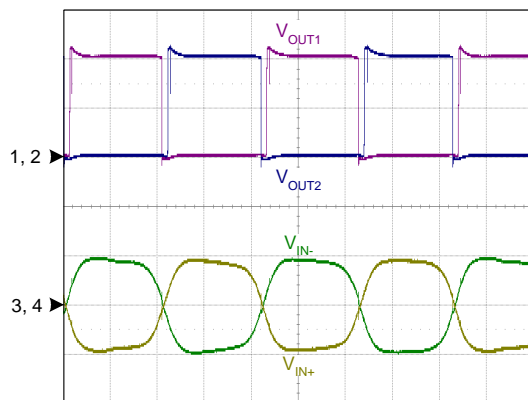

Ch1 : V_{OUT1} , 5V/Div, DC
 Ch2 : V_{OUT2} , 5V/Div, DC
 Ch3 : V_{IN+} , 100mV/Div, AC
 Ch4 : V_{IN-} , 100mV/Div, AC
 Time : 2ms/Div

Rotation Waveform 2

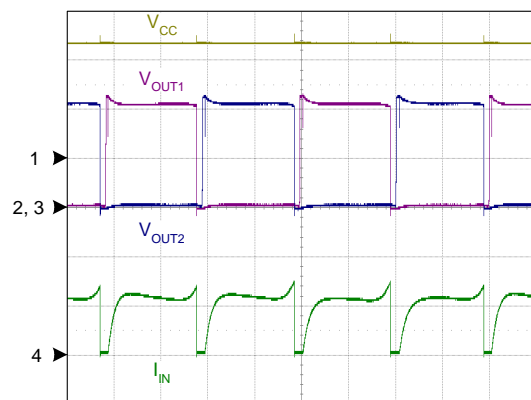

Ch1 : V_{CC} , 5V/Div, DC
 Ch2 : V_{OUT1} , 5V/Div, DC
 Ch3 : V_{OUT2} , 5V/Div, DC
 Ch4 : I_{IN} , 500mA/Div, DC
 Time : 2ms/Div

Operating Waveforms (Cont.)

Rotation Waveform 3

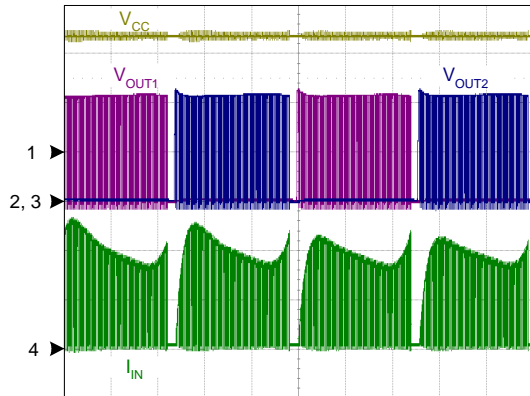

Ch1 : V_{CC}, 5V/Div, DC
 Ch2 : V_{OUT1}, 5V/Div, DC
 Ch3 : V_{OUT2}, 5V/Div, DC
 Ch4 : I_{IN}, 200mA/Div, DC
 Time : 2ms/Div

Power ON Waveform

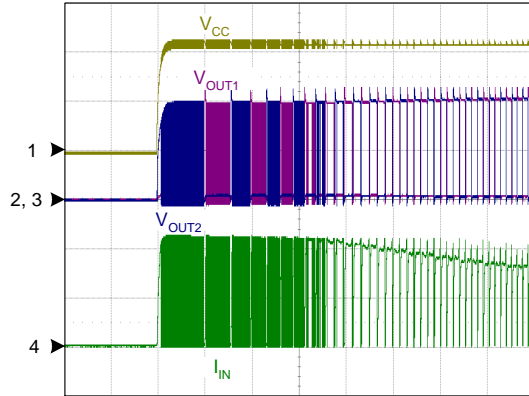

Ch1 : V_{CC}, 5V/Div, DC
 Ch2 : V_{OUT1}, 5V/Div, DC
 Ch3 : V_{OUT2}, 5V/Div, DC
 Ch4 : I_{IN}, 500mA/Div, DC
 Time : 50ms/Div

Lock Protection Waveform 1

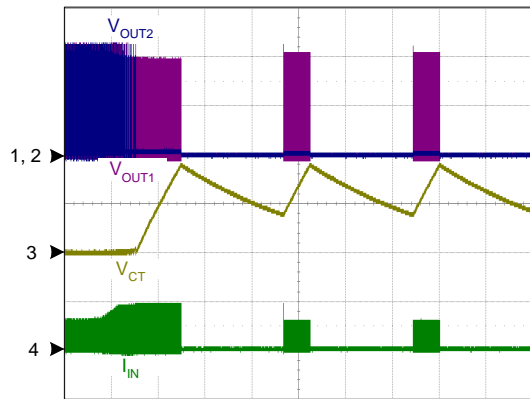

Ch1 : V_{OUT1}, 5V/Div, DC
 Ch2 : V_{OUT2}, 5V/Div, DC
 Ch3 : V_{CT}, 2V/Div, DC
 Ch4 : I_{IN}, 1A/Div, DC
 Time : 1s/Div

Lock Protection Waveform 2

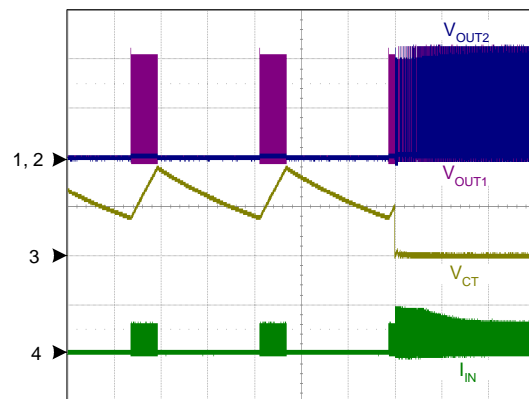

Ch1 : V_{OUT1}, 5V/Div, DC
 Ch2 : V_{OUT2}, 5V/Div, DC
 Ch3 : V_{CT}, 2V/Div, DC
 Ch4 : I_{IN}, 1A/Div, DC
 Time : 1s/Div

Pin Description

| PIN | | FUNCTION |
|-----|-------|---|
| NO. | NAME | |
| 1 | PGND | Power Stage GND. |
| 2 | OUT2 | H-bridge Output Connection. The output stage is a H-bridge formed by four transistors and four-protection diode for switching applications. |
| 3 | VM | Supply Voltage for Output Stage Input Pin. |
| 4 | VCC | Supply Voltage Input Pin. |
| 5 | OSCH | Setting of the OSC Waveform High Level Voltage. Use a voltage divider from 6VREG to set OSC waveform high-level voltage. |
| 6 | OSCL | Setting of the OSC Waveform Low Level Voltage. Use a voltage divider from 6VREG to set OSC waveform low-level voltage. |
| 7 | SET | Speed Setting. An external voltage into SET pin to set fan speed. |
| 8 | MIN | Minimum Speed Setting. Use a voltage divider from 6VREG to set MIN pin voltage for setting minimum speed. |
| 9 | PWM | PWM Signal Input Terminal. |
| 10 | OSC | Oscillator Frequency Setting. Connect a capacitor to SGND to set oscillation frequency. |
| 11 | FG | Rotation Speed Output. This is an open-collector output. |
| 12 | IN+ | Hall Input +. Connect to hall element positive output. |
| 13 | HB | Hall Bias. This is a 1.3V constant-voltage output for hall element bias. |
| 14 | IN- | Hall Input -. Connect to hall element negative output. |
| 15 | CT | Shutdown Time and Restart Time Setting. Connect a capacitor to SGND to set shutdown time and restart time in lock mode. |
| 16 | 6VREG | 6V Regulator Output. This is a 6V constant-voltage output for application circuit biases. |
| 17 | SGND | Control Stage GND. |
| 18 | OUT1 | H-bridge Output Connection. The output stage is a H-bridge formed by four transistors and four-protection diode for switching applications. |
| 19 | PGND | Power Stage GND. |
| 20 | PGND | Power Stage GND. |

Block Diagram

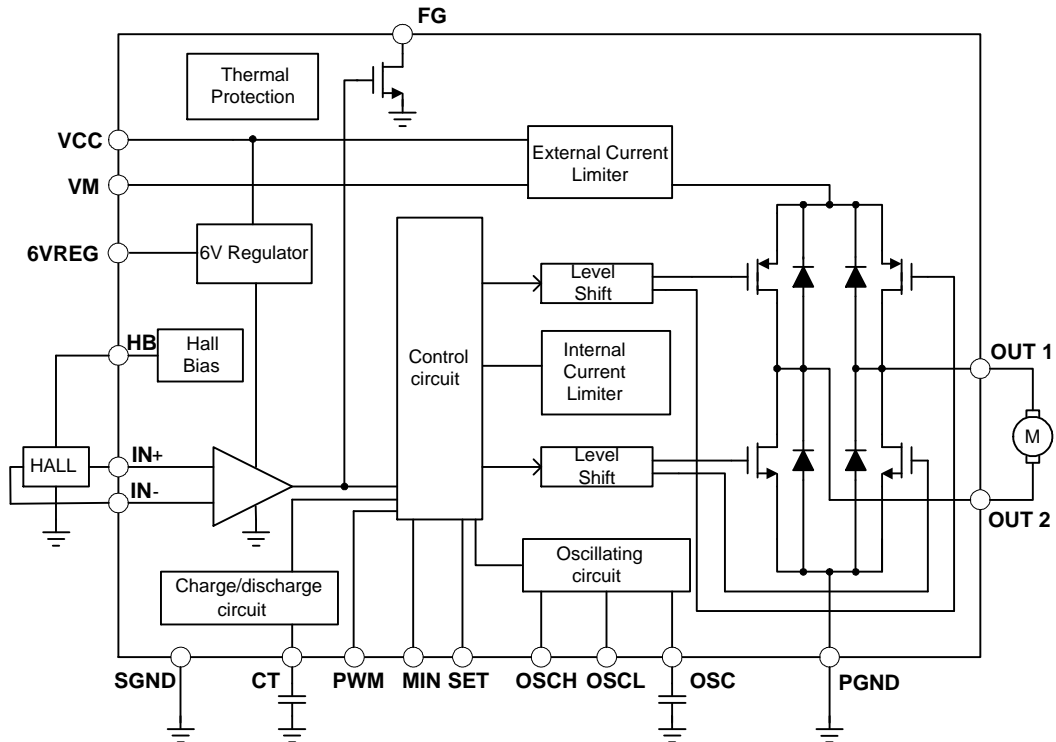

Typical Application Circuits

1. With external current limiter

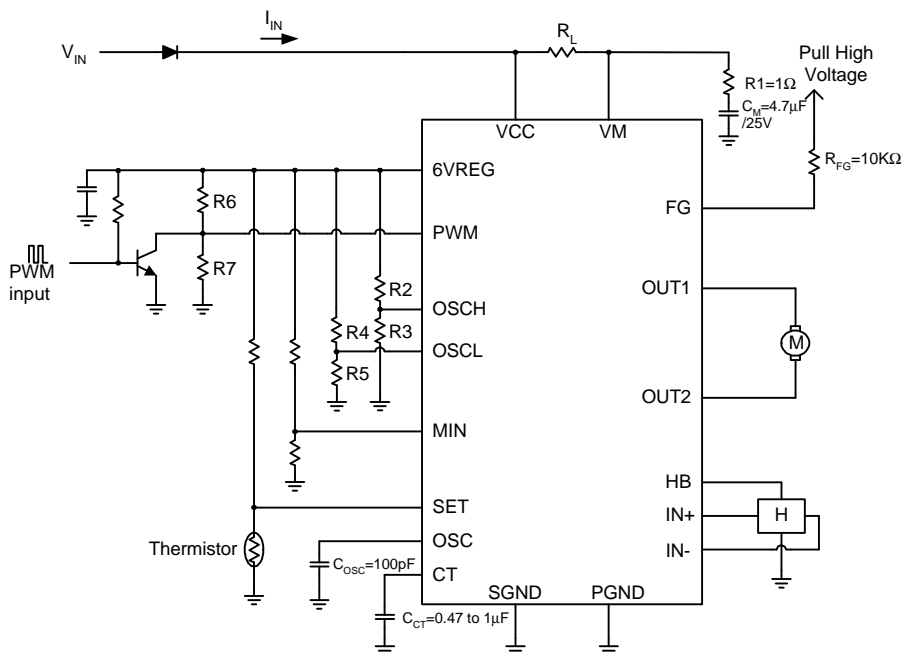

Typical Application Circuits (Cont.)

2. Without external current limiter

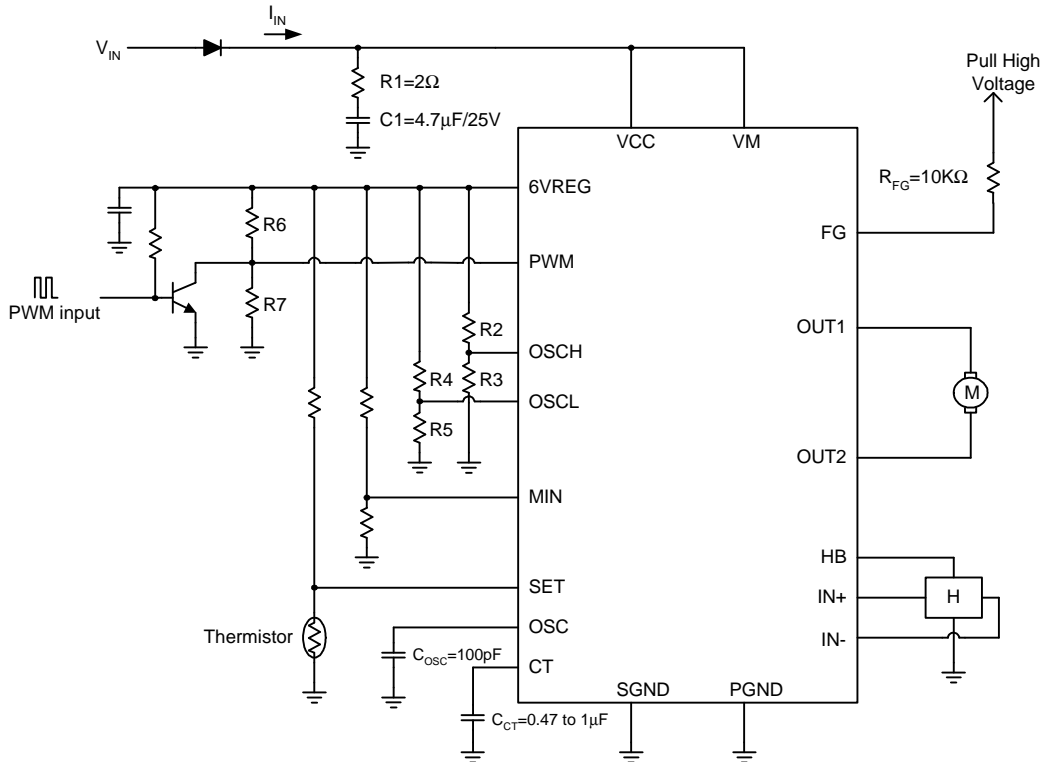

Note 3: In hot plug application, it's necessary to protect against a hot plug input voltage overshoot. Placing a resistor (R1) in series with a capacitor (C1 or C_M) dampens the overshoot.

Function Description

Variable Speed Control

The APX9270 is designed with a variable speed controller which has two external input signals, a temperature signal sensed by a thermistor and an external PWM signal.

Temperature Speed Control

Using thermistor get temperature to make SET pin voltage. The fan's speed is decided by comparing OSC and SET pin voltage. In addition, the lowest drive duty is set by comparing the OSC oscillating voltage and MIN pin voltage (only for temperature speed control side). Temperature control system works by comparing the voltage of SET and OSC. When SET voltage is lower than OSC voltage, one OUT pulled high and another OUT pulled low. On the contrary, when SET voltage is higher than OSC voltage, upper side transistors are OFF; meanwhile, the coil current re-circulates lower side transistor. Therefore, with decreasing SET voltage, the output ON-Duty will be increasing, which results in the increasing of the coil current and motor rotation speed.

External PWM Speed Control

This is a pin for the direct PWM speed control. PWM pin input is pulled down to GND when it is not used. The minimum duty is performed by R6 and R7 resistances (see Typical Application Circuit). R7 is left open if you want to stop rotation when PWM duty is 0%. (see Figure 1: Rotation Control Curve)

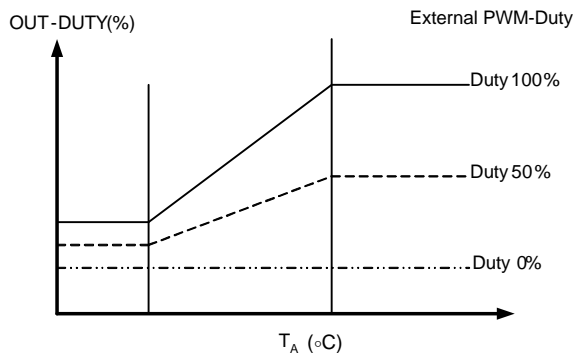

Figure 1: Rotation Control Curve

Lockup Protection and Automatic Restart

The APX9270 provides the lockup protection and automatic restart functions to prevent the coil burnout while

the fan is locked. Connecting the capacitor from CT pin to GND determines the shutdown time and restart time. As the fan is locked, the charge/discharge circuit will charge the CT capacitor to 3.6V by a 2.2 μ A source current for a locked detection time, and then the circuit will switch the capacitor to discharge. During the discharging interval, the output drivers are switched off until the CT voltage is discharged to 1.6V by a 0.22 μ A sink current, and the circuit will switch the capacitor to charge. In the charging interval, the IC enters the restart time; one output is high and another is low, which makes a torque for fan rotation until the CT voltage is charged to 3.6V by a 2.2 μ A source current. If the locked condition still remains, the charge/discharge process will be recurred until the locked condition is released (see Figure 2: Lock/Auto Restart Waveform).

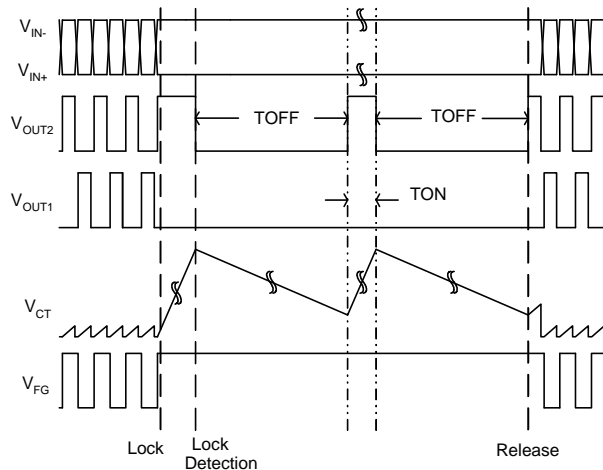

Figure 2: Lock/Auto Restart Waveform

Current Limit

The APX9270 includes both internal and external current limiters. External current limiter value is programmed by R_L which is located between VCC pin and VM pin. The external current limiter works when the voltage difference between both sides of R_L raises to be 0.48V or higher. For example, the $R_L=0.5\Omega$, the external current limiter value is fixed and internally set at 960mA. The internal current limiter value is different in rotation mode and lock mode. It is 1.2A in rotation mode, but it decreases to 0.6A in lock mode. This feature can reduce power consumption while the fan is locked. In general application, it is

Function Description (Cont.)

Current Limit (Cont.)

recommended to short R_L resistance and remove C_M capacitor to disable external current limiter because the internal current limiter is sufficient to avoid overload.

FG Output

The FG pin is an open drain output connecting a pull up resistor to a high level voltage for the speed detection function. When V_{IN-} is larger than V_{IN+} , the V_{FG} is low (switch on); when V_{IN-} is smaller than V_{IN+} , the V_{FG} is high (switch off). Leave it open when not in using.

Thermal Protection

The APX9270 is designed with a thermal protection to protect the IC from the damage of over temperature. When internal junction temperature reaches 160°C, the output devices will be switched off. When the IC's junction temperature cools by 20°C, the thermal sensor will turn the output devices on again resulting in a pulsed output during continuous thermal overload.

Truth Table

| Input | | | | Output | | | Mode | |
|-------|-----|-----|-----|--------|------|------|------|---|
| SET | PWM | IN- | IN+ | CT | OUT1 | OUT2 | | FG |
| L | L | H | L | L | H | L | L | Rotation (Drive) |
| | L | L | H | | L | H | OFF | |
| H | L | H | L | | OFF | L | L | Rotation (Regeneration) |
| | L | L | H | | L | OFF | OFF | |
| - | H | H | L | | OFF | L | L | Output Regeneration Mode by External Signal |
| - | H | L | H | | L | OFF | OFF | |
| - | - | H | L | H | OFF | L | L | Lock Mode |
| - | - | L | H | | L | OFF | OFF | |

SET or PWM=[L], "L" means that SET or PWM voltage is smaller than OSC voltage.

Also, SET or PWM=[H], "H" means that SET or PWM voltage is greater than OSC voltage.

Application Information

Input Protection Diode & Capacitor

The input protection diode (D1) between supply voltage and VCC pin has to be used to prevent the reverse current flowing into the supply power. However, the protection diode will cause a voltage drop on the supply voltage. The current rating of the diode must be larger than the maximum output current. For the noise reduction purpose, a capacitor ($C1/C_M$) must be connected between VCC/VM and SGND/PGND. The $C1/C_M$ should be placed near the device VCC/VM pin as close as possible.

Setting of the Oscillator Frequency and Output Voltage

The oscillator is used for PWM speed control. Compare the OSC and SET pin voltages can decide PWM duty and PWM frequency depends on the oscillator frequency. The oscillator is based on internal charge/discharge circuit. The circuit charges C_{OSC} to V_{OSCH} by a 10 μ A source current,

and then it will discharge C_{OSC} to V_{OSCL} by 10 μ A sink current. The circuit can generate a triangular waveform. The triangular waveform is determined by C_{OSC} , R2, R3, R4, and R4. (see Typical Application Circuit)

$$V_{OSCH} = V_{6VREG} \times \frac{R3}{R2 + R3}$$

$$V_{OSCL} = V_{6VREG} \times \frac{R5}{R4 + R5}$$

$$f_{OSC} = \frac{0.5 \times I_{OSC1}}{(V_{OSCH} - V_{OSCL}) \times C_{OSC}}$$

For example:

$$C_{OSC} = 100\text{pF}, R2 = R5 = 10\text{k}\Omega,$$

$$R3 = R4 = 20\text{k}\Omega, I_{OSC1} = 10\mu\text{A}$$

$$V_{OSCH} = 4\text{V}, V_{OSCL} = 2\text{V}, f_{OSC} = 25\text{kHz}$$

The recommended OSC frequency range is from 22kHz to 32kHz.

Application Information (Cont.)

HB Bias Output and Hall Input Signals

The IC outputs a 1.3V voltage on HB pin to provide bias for the external hall element. The IC also has two pins IN+ and IN- to receive the hall signals from the hall element. The hall signals are very weak so the layout tracks must be short and far away from those noise sources to avoid noise coupling. The hall input amplifier has 20mV hysteresis. Therefore, the recommended differential hall input voltage should be more than 60mV.

CT Capacitor

The capacitor that is connected from CT pin to GND determines the shutdown time and restart time.

$$\text{Locked Detection Time} = \frac{C_{CT} \times (V_{CT1} - 0.2V)}{I_{CT1}}$$

$$\text{Restart Time} = \frac{C_{CT} \times (V_{CT1} - V_{CT2})}{I_{CT1}}$$

$$\text{Shutdown Time} = \frac{C_{CT} \times (V_{CT1} - V_{CT2})}{I_{CT2}}$$

where

C_{CT} = CT pin capacitor

For example:

$$V_{CC} = 12V, C_{CT} = 1\mu F$$

$$\text{Locked Detection Time} = 1.545 \text{ s}$$

$$\text{Restart Time} = 0.909 \text{ s}$$

$$\text{Shutdown Time} = 9.091 \text{ s}$$

The value of charge capacitor in the range of 0.47 μ F to 1 μ F is recommended.

FG Resistor

The value of the FG resistor could be decided by the following equation

$$R_{FG} = \frac{V_{6VREG} - V_{FG}}{I_{FG}}$$

For example:

$$V_{6VREG} = 6V, I_{FG} = 5mA, V_{FG} = 0.2V, R_{FG} = 1.16k\Omega$$

The value of resistor in the range of 1k Ω to 10k Ω is recommended.

Thermal Pad Consideration

The thermal pad on the bottom of the TSSOP-20P package should be soldered down to a copper pad on the circuit board. Heat can be conducted away from the thermal pad through the copper plane to ambient. If the copper plane is not on the top surface of the circuit board, 8 to 10 vias of 13 mil or smaller in diameter should be used to thermally couple the thermal pad to the bottom plane. For good thermal conduction, the vias must be plated through and solder filled. The copper plane is used to conduct heat away from the thermal pad should be as large as practical.

If the ambient temperature is higher than 25°C, a larger copper plane or forced-air cooling will be required to keep the APX9270 junction temperature below the thermal protection temperature (160°C).

Thermal Consideration

Refer to "Maximum Power Dissipation vs. Ambient Temperature", the IC is safe to operate below the curve and it will cause the thermal protection if the operating area is above the line. For example, $T_A = 50^\circ C$, the SSOP-20 package maximum power dissipation is about 0.95W.

Power dissipation can be calculated by the following equation:

$$P_D = (V_{CC} - |V_{OUT1} - V_{OUT2}|) \times I_{OUT} + V_{CC} \times I_{CC}$$

For example:

When $V_{CC} = 12V$, $I_{CC} = 6mA$, $I_{OUT} = 300mA$, $V_{OUT1} = 11.66V$, $V_{OUT2} = 0.13V$, then $P_D = 0.213W$

According the power dissipation issue, we could adapt this SSOP-20 package.

Package Information

SSOP-20

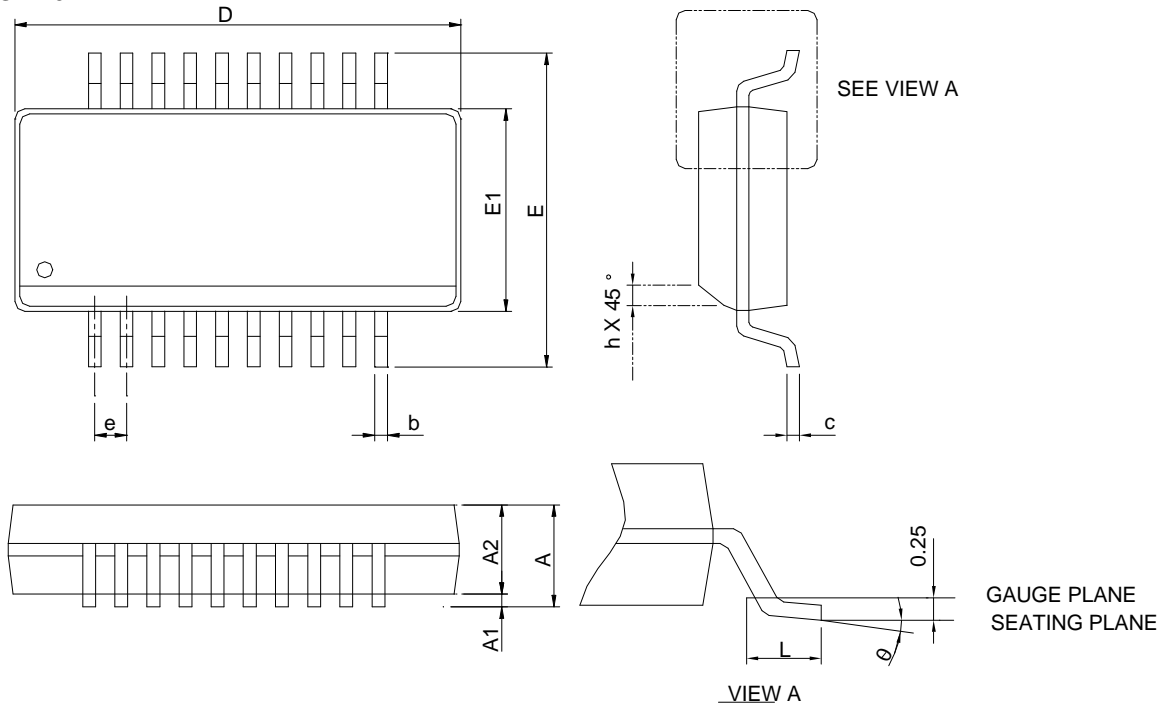

| SYMBOL | SSOP-20 | | | |
|--------|-------------|------|-----------|-------|
| | MILLIMETERS | | INCHES | |
| | MIN. | MAX. | MIN. | MAX. |
| A | | 1.75 | | 0.069 |
| A1 | 0.10 | 0.25 | 0.004 | 0.010 |
| A2 | 1.24 | | 0.049 | |
| b | 0.20 | 0.30 | 0.008 | 0.012 |
| c | 0.15 | 0.25 | 0.006 | 0.010 |
| D | 8.56 | 8.76 | 0.337 | 0.345 |
| E | 5.80 | 6.20 | 0.228 | 0.244 |
| E1 | 3.80 | 4.00 | 0.150 | 0.157 |
| e | 0.635 BSC | | 0.025 BSC | |
| L | 0.40 | 1.27 | 0.016 | 0.050 |
| h | 0.25 | 0.50 | 0.010 | 0.020 |
| theta | 0° | 8° | 0° | 8° |

- Note : 1. Follow JEDEC MO-137 AD.
 2. Dimension "D" does not include mold flash, protrusions or gate burrs. Mold flash, protrusion or gate burrs shall not exceed 6 mil per side .
 3. Dimension "E" does not include inter-lead flash or protrusions. Inter-lead flash and protrusions shall not exceed 10 mil per side.

Package Information

TSSOP-20P

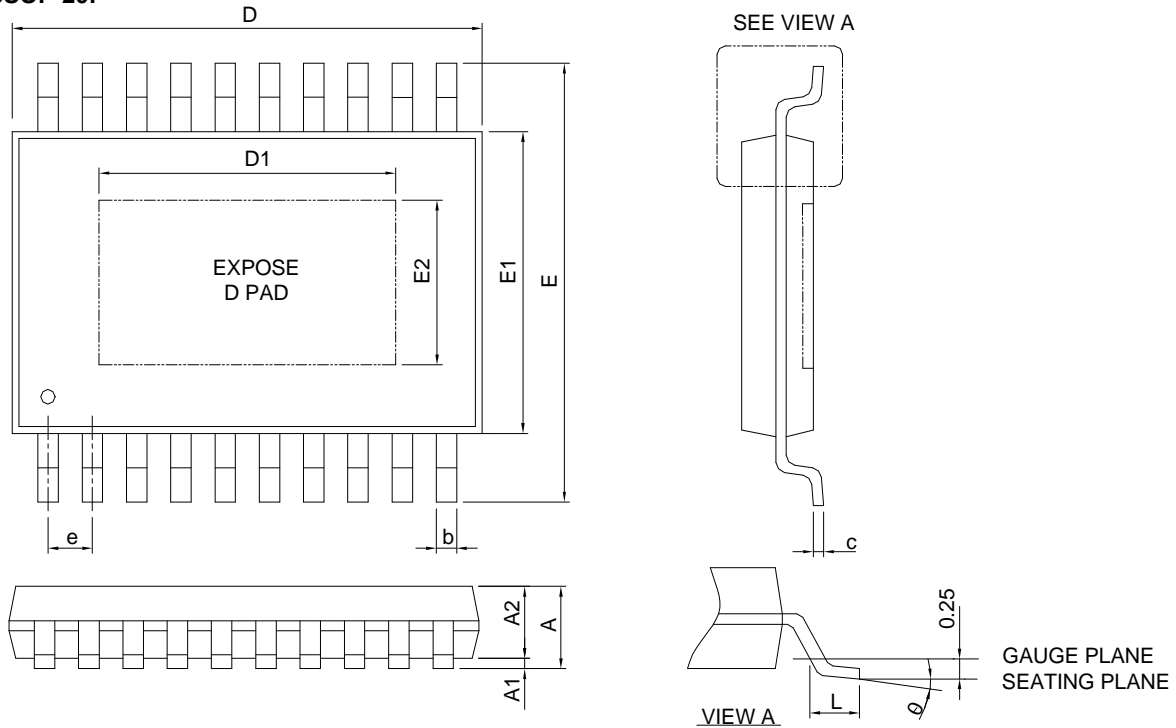

| SYMBOL | TSSOP-20P | | | |
|--------|-------------|------|-----------|-------|
| | MILLIMETERS | | INCHES | |
| | MIN. | MAX. | MIN. | MAX. |
| A | | 1.20 | | 0.047 |
| A1 | 0.05 | 0.15 | 0.002 | 0.006 |
| A2 | 0.80 | 1.05 | 0.031 | 0.041 |
| b | 0.19 | 0.30 | 0.007 | 0.012 |
| c | 0.09 | 0.20 | 0.004 | 0.008 |
| D | 6.40 | 6.60 | 0.252 | 0.260 |
| D1 | 2.20 | 5.00 | 0.087 | 0.197 |
| E | 6.40 BSC | | 0.252 BSC | |
| E1 | 4.30 | 4.50 | 0.169 | 0.177 |
| E2 | 1.50 | 4.00 | 0.059 | 0.157 |
| e | 0.65 BSC | | 0.026 BSC | |
| L | 0.45 | 0.75 | 0.018 | 0.030 |
| θ | 0° | 8° | 0° | 8° |

- Note : 1. Follow JEDEC MO-153 ACT.
 2. Dimension "D" does not include mold flash, protrusions or gate burrs. Mold flash, protrusion or gate burrs shall not exceed 6 mil per side.
 3. Dimension "E1" does not include inter-lead flash or protrusions. Inter-lead flash and protrusions shall not exceed 10 mil per side.

Carrier Tape & Reel Dimensions

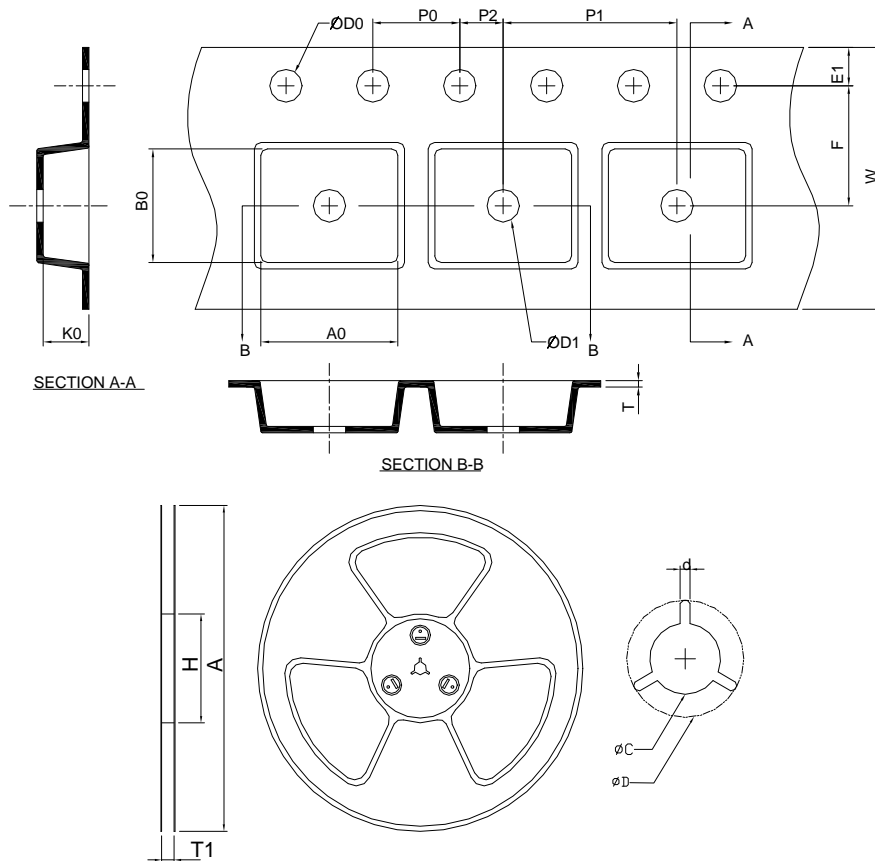

| Application | A | H | T1 | C | d | D | W | E1 | F |
|-------------|-------------|------------|--------------------|--------------------|----------|-------------------|------------|------------|------------|
| SSOP-20 | 330 ±2.00 | 50 MIN. | 16.4+2.00 -0.00 | 13.0+0.50 -0.20 | 1.5 MIN. | 20.2 MIN. | 16.0 ±0.30 | 1.75 ±0.10 | 7.5 ±0.1 |
| | P0 | P1 | P2 | D0 | D1 | T | A0 | B0 | K0 |
| | 4.0 ±0.10 | 8.0 ±0.10 | 2.0 ±0.10 | 1.5+0.10 -0.00 | 1.5 MIN. | 0.6+0.00 -0.40 | 6.40 ±0.20 | 9.00 ±0.20 | 2.10 ±0.20 |
| Application | A | H | T1 | C | d | D | W | E1 | F |
| TSSOP-20P | 330.0 ±2.00 | 50 MIN. | 16.4+2.00 -0.00 | 13.0+0.50 -0.20 | 1.5 MIN. | 20.2 MIN. | 16.0 ±0.30 | 1.75 ±0.10 | 7.50 ±0.10 |
| | P0 | P1 | P2 | D0 | D1 | T | A0 | B0 | K0 |
| | 4.00 ±0.10 | 8.00 ±0.10 | 2.00 ±0.10 | 1.5+0.10 -0.00 | 1.5 MIN. | 0.30 ±0.05 | 6.9 ±0.20 | 6.90 ±0.20 | 1.60 ±0.20 |

(mm)

Devices Per Reel

| Package Type | Unit | Quantity |
|--------------|-------------|----------|
| SSOP-20 | Tape & Reel | 2500 |
| TSSOP-20P | Tape & Reel | 2000 |

Reflow Condition (IR/Convection or VPR Reflow)

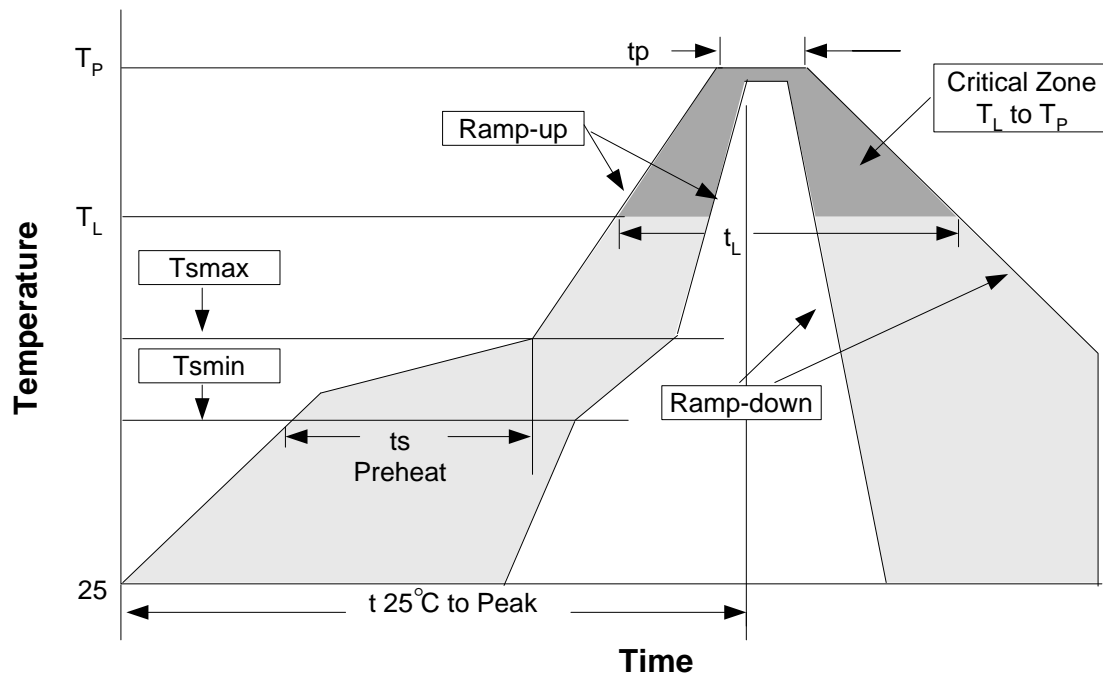

Reliability Test Program

| Test item | Method | Description |
|---------------|---------------------|-------------------------------|
| SOLDERABILITY | MIL-STD-883D-2003 | 245°C, 5 sec |
| HOLT | MIL-STD-883D-1005.7 | 1000 Hrs Bias @ 125°C |
| PCT | JESD-22-B, A102 | 168 Hrs, 100% RH, 121°C |
| TST | MIL-STD-883D-1011.9 | -65°C~150°C, 200 Cycles |
| ESD | MIL-STD-883D-3015.7 | VHBM > 2KV, VMM > 200V |
| Latch-Up | JESD 78 | 10ms, 1 _{tr} > 100mA |

Classification Reflow Profiles

| Profile Feature | Sn-Pb Eutectic Assembly | Pb-Free Assembly |
|--|-------------------------|------------------|
| Average ramp-up rate (T _L to T _P) | 3°C/second max. | 3°C/second max. |
| Preheat | | |
| - Temperature Min (T _{smin}) | 100°C | 150°C |
| - Temperature Max (T _{smax}) | 150°C | 200°C |
| - Time (min to max) (t _s) | 60-120 seconds | 60-180 seconds |
| Time maintained above: | | |
| - Temperature (T _L) | 183°C | 217°C |
| - Time (t _L) | 60-150 seconds | 60-150 seconds |
| Peak/Classification Temperature (T _p) | See table 1 | See table 2 |
| Time within 5°C of actual Peak Temperature (t _p) | 10-30 seconds | 20-40 seconds |
| Ramp-down Rate | 6°C/second max. | 6°C/second max. |
| Time 25°C to Peak Temperature | 6 minutes max. | 8 minutes max. |

Note: All temperatures refer to topside of the package. Measured on the body surface.

Classification Reflow Profiles (Cont.)

Table 1. SnPb Eutectic Process – Package Peak Reflow Temperatures

| Package Thickness | Volume mm ³ <350 | Volume mm ³ ≥350 |
|-------------------|--------------------------------|--------------------------------|
| <2.5 mm | 240 +0/-5°C | 225 +0/-5°C |
| ≥2.5 mm | 225 +0/-5°C | 225 +0/-5°C |

Table 2. Pb-free Process – Package Classification Reflow Temperatures

| Package Thickness | Volume mm ³ <350 | Volume mm ³ 350-2000 | Volume mm ³ >2000 |
|-------------------|--------------------------------|------------------------------------|---------------------------------|
| <1.6 mm | 260 +0°C* | 260 +0°C* | 260 +0°C* |
| 1.6 mm – 2.5 mm | 260 +0°C* | 250 +0°C* | 245 +0°C* |
| ≥2.5 mm | 250 +0°C* | 245 +0°C* | 245 +0°C* |

*Tolerance: The device manufacturer/supplier **shall** assure process compatibility up to and including the stated classification temperature (this means Peak reflow temperature +0°C. For example 260°C+0°C) at the rated MSL level.

Customer Service

Anpec Electronics Corp.

Head Office :

No.6, Dusing 1st Road, SBIP,
Hsin-Chu, Taiwan
Tel : 886-3-5642000
Fax : 886-3-5642050

Taipei Branch :

2F, No. 11, Lane 218, Sec 2 Jhongsing Rd.,
Sindian City, Taipei County 23146, Taiwan
Tel : 886-2-2910-3838
Fax : 886-2-2917-3838