

Single-Phase Full-Wave Motor Driver for Silent Fan Motor

Features

- **Single-Phase Full Wave Fan Driver**
- **Silent Driver**
- **Low Supply Current**
- **Speed Controllable by PWM Input Signal**
- **Built-in Quick Start Function**
- **Lock Protection and Auto Restart Function**
- **Enhance Low Duty Start UP Power**
- **FG (Rotation Speed Detection) Output**
- **Built-in Current Limit Circuit**
- **Built-in Thermal Protection Circuit**
- **Lead Free and Green Devices Available (RoHS Compliant)**

General Description

The APX9277 is a single-phase full wave motor driver for DC fan motors, and speed controlled by PWM input signal. The output signals of this IC are the amplifications of hall input signals. It is suitable for cooler DC fan that needs silent drivers. The device has a built-in lock protection function. When the fan is locked, the device will enter the lockup protection mode. It also has the thermal shut-down protection function. In normal operation, supply current is less than 5mA, but in standby mode (PWM=Low), it is just around 3mA. Moreover, this feature will shut down the amplifiers and FG. The APX9277 is available in MSOP-8 package.

Applications

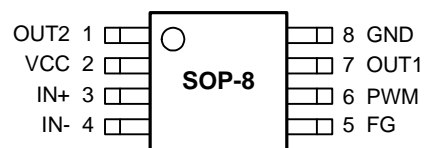
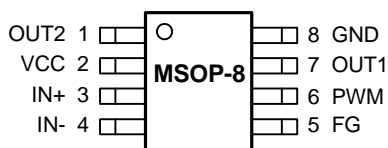

- **Motor Drivers for Silent Fans**

Pin Configuration

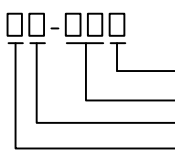
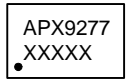

ANPEC reserves the right to make changes to improve reliability or manufacturability without notice, and advise customers to obtain the latest version of relevant information to verify before placing orders.

Ordering and Marking Information

APX9277 	Package Code K : SOP-8 X : MSOP-8 Operating Ambient Temperature Range I : -40 to 105 °C Handling Code TR : Tape & Reel Assembly Material G : Halogen and Lead Free Device
APX9277 K : 	XXXXX - Date Code
APX9277 X : 	XXXXX - Date Code

Note: ANPEC lead-free products contain molding compounds/die attach materials and 100% matte tin plate termination finish; which are fully compliant with RoHS. ANPEC lead-free products meet or exceed the lead-free requirements of IPC/JEDEC J-STD-020D for MSL classification at lead-free peak reflow temperature. ANPEC defines "Green" to mean lead-free (RoHS compliant) and halogen free (Br or Cl does not exceed 900ppm by weight in homogeneous material and total of Br and Cl does not exceed 1500ppm by weight).

Absolute Maximum Ratings (Note 1)

Symbol	Parameter	Rating	Unit
V _{CC}	VCC Pin Supply Voltage (VCC to GND)	-0.3 to 20	V
I _{OUT}	Output Pin Output Current	1	A
V _{OUT}	Output Pin(OUT1, OUT2) Output Voltage	-0.3 to 20	V
V _{FG}	FG Pin Output Voltage	-0.3 to 20	V
I _{FG}	FG Pin Output Sink Current	10	mA
T _J	Junction Temperature	-40 to 150	°C
T _{STG}	Storage Temperature	-65 to 150	°C
T _{SDR}	Maximum Lead Soldering Temperature, 10 Seconds	260	°C

Note1: Stresses beyond those listed under "absolute maximum ratings" may cause permanent damage to the device. These are stress ratings only and functional operation of the device at these or any other conditions beyond those indicated under "recommended operating conditions" is not implied. Exposure to absolute maximum rating conditions for extended periods may affect device reliability.

Thermal Characteristics

Symbol	Parameter	Typical Value	Unit
θ _{JA}	Junction-to-Ambient Resistance in Free Air ^(Note 2)	MSOP-8	215
		SOP-8	156.25
P _D	Power Dissipation, T _A =25°C	MSOP-8	0.585
		SOP-8	0.8

Note 2: θ_{JA} is measured with the component mounted on a high effective thermal conductivity test board in free air.

Recommended Operation Conditions

Symbol	Parameter	Range	Unit
V_{CC}	VCC Pin Supply Voltage	2.5 to 17	V
V_{ICM}	Hall Input Common Phase Input Voltage Range	0 to 5	V
T_A	Operating Ambient Temperature	-40 to 105	°C
T_J	Junction Temperature	-40 to 125	°C

Electrical Characteristics ($V_{CC}=12V$, $T_A=25\text{ }^\circ\text{C}$. unless otherwise noted)

Symbol	Parameter	Test Conditions	APX9277			Unit
			Min.	Typ.	Max.	
SUPPLY CURRENT						
I_{CC1}	VCC Operating Current	Rotation Mode	2	5	8	mA
I_{CC2}	VCC Standby Supply Current	Lock Protect T_{OFF} or PWM=0	1	3	5	mA
PWM CONTROL						
V_{PWMH}	PWM Input High Level Voltage		2.5	-	$V_{CC}+0.3$	V
V_{PWML}	PWM Input Low Level Voltage		-0.3	-	0.8	V
I_{PWMH}	PWM High Level Input Current	PWM=5V	-	10	20	μA
I_{PWML}	PWM Low Level Input Current	PWM=0V	-	-10	-20	μA
F_{PWM}	PWM Input Frequency		20	-	50	KHz
DST	Start Up PWM Duty	FPWM=25KHz	2	6	10	%
		FPWM=50KHz	4	12	20	
HALL SENSITIVITY						
V_{HOFS}	Input Offset Voltage		-	-	± 6	mV
V_{HYS}	FG Hysteresis Voltage		± 5	± 10	± 15	mV
OUTPUT DRIVERS						
G_{IO}	Input-Output Gain	V_{OUT}/H_{+H} (ratio)	51	52	53	dB
V_O	Output Lower Saturation Voltage	$I_{OUT}=400\text{mA}$, Upper and Lower Total	-	0.4	0.5	V
V_{FGL}	FG Pin Low Voltage	$I_{FG}=5\text{mA}$	-	0.2	0.4	V
I_{FGL}	FG Pin Leakage Current	$V_{FG}=12V$	-	-	0.1	μA
LOCK PROTECTION						
T_{ON}	Lock Detection On Time		0.35	0.5	0.65	sec
T_{OFF}	Lock Detection Off Time		3.5	5	6.5	sec
T_{QS}	Quick Start Enable Time		-	66.5	-	ms
PROTECTION						
I_{LIM}	Internal Current Limit		-	1000	-	mA
THERMAL SHUTDOWN						
OTS	Over Temperature Shutdown Threshold		-	165	-	°C
	Over Temperature Shutdown Hysteresis		-	30	-	°C

Typical Operating Characteristics

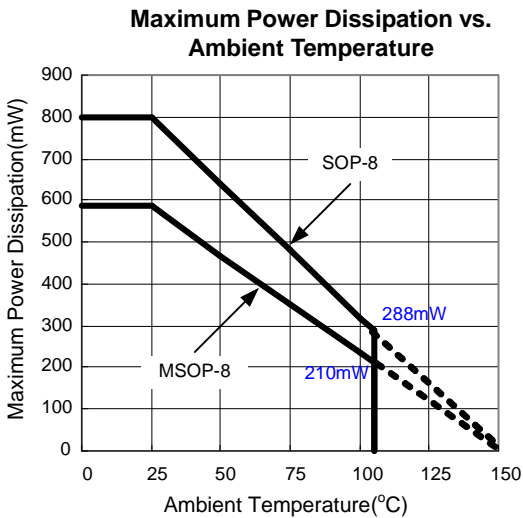
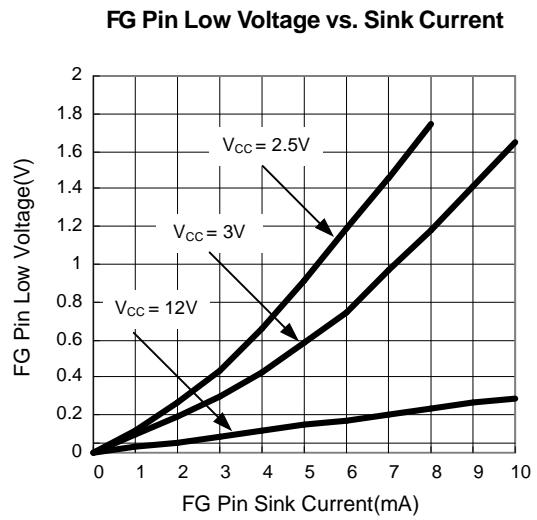
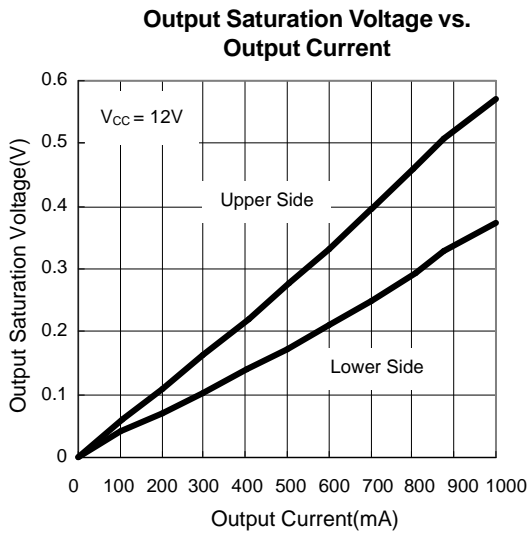
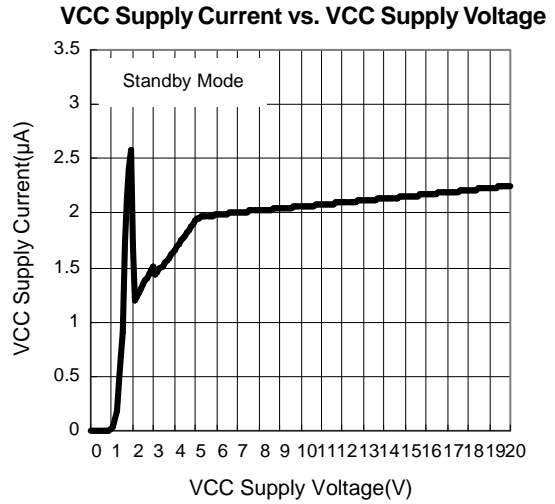
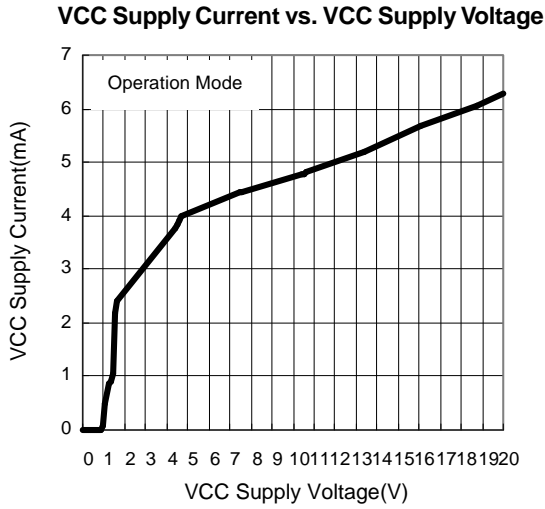

Pin Description

PIN		FUNCTION
NO.	NAME	
1	OUT2	H-bridge Output Connection.
2	VCC	Supply Voltage Input Pin.
3	IN+	Hall Input +. Connect to hall element positive output.
4	IN-	Hall Input -. Connect to hall element negative output.
5	FG	Rotation Speed Output. This is an open-collector output.
6	PWM	PWM Signal Input Terminal.
7	OUT1	H-bridge Output Connection.
8	GND	Power GND.

Block Diagram

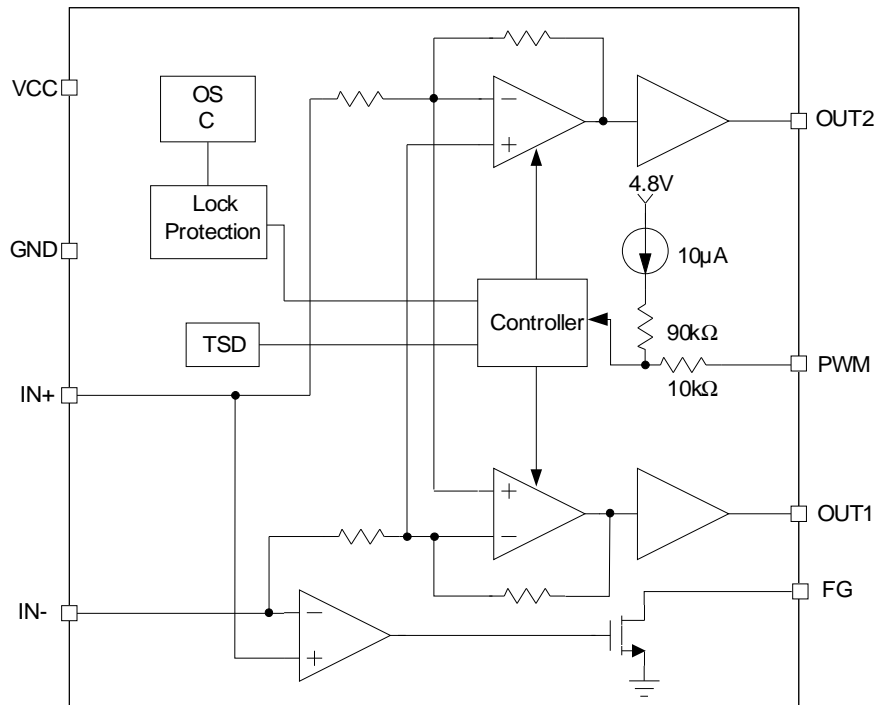

Typical Application Circuit

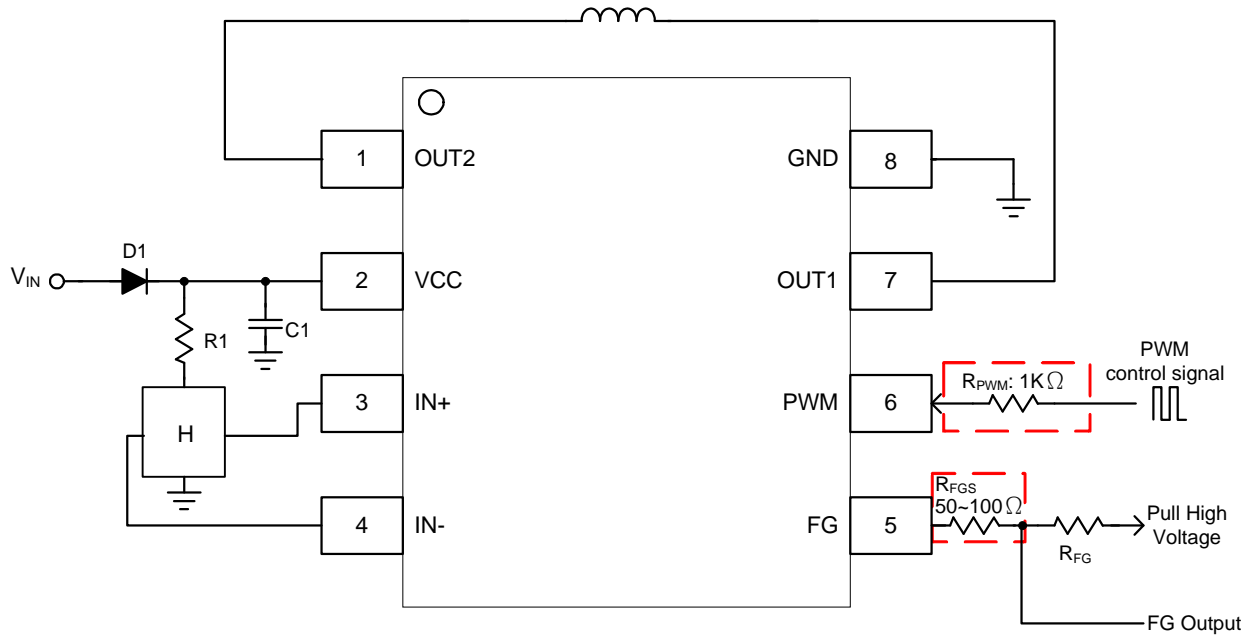

Note: R_{PWM} and R_{FGS} are optional to protect internal circuit for abnormal voltage stress.

Function Description

Lockup Protection and Automatic Restart

This IC detects the rotation of the motor by the hall signal, and adjusts lock detection ON time (T_{ON}) and lock detection OFF time (T_{OFF}) by the internal counter. These times (T_{ON} , T_{OFF}) are shown below.

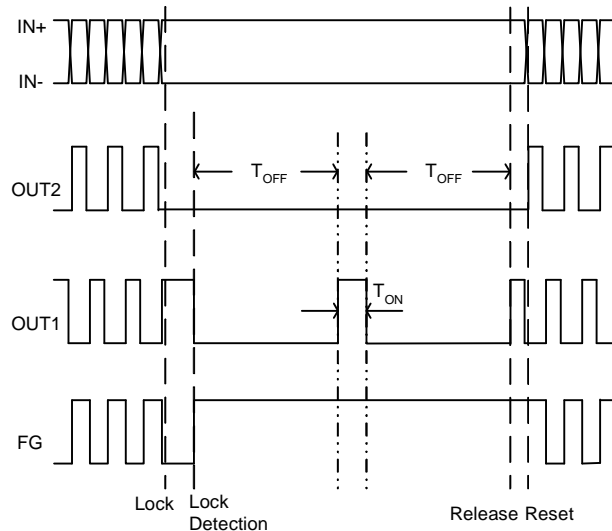

Figure 1. Lock Protection and Automatic Protection Waveform

Quick Start and Standby mode

This IC would enter standby mode when the PWM input keeps at a low level for more than 66.5ms (typ.). In standby mode, it will shutdown amplifier and FG. Thus, the supply current is around 3mA. In standby mode, the lock protection function doesn't work, therefore, the starting fan is unobstructed when releasing standby mode.

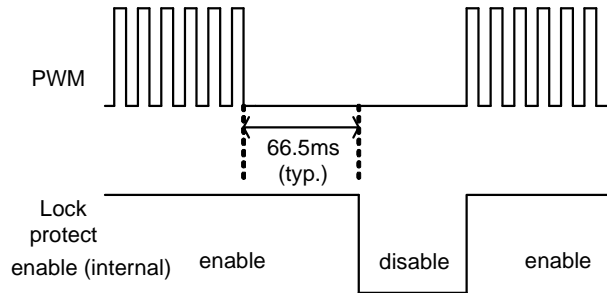

Figure 2. Quick Start Waveform

Frequency Generator Function

The FG pin is an open collector output, connecting a pull up resistor to a high level voltage for the frequency generator function. During the Lock Mode, the FG is always high (switch off) (See Truth Table). The terminal should be opened when not in using.

Thermal Protection

The APX9277 has a thermal protection. When internal junction temperature reaches 165°C, the output devices will be switched off. When the IC's junction temperature cools by 30°C, the thermal sensor will turn the output devices on again, resulting in a pulsed output during continuous thermal protection.

Truth Table

Input			Output			Mode
IN-	IN+	PWM	OUT1	OUT2	FG	
L	H	H	H	L	L	Operation Mode
H	L		L	H	OFF	
H	L	L	L	L	OFF	
L	H		L	L	L	
L	H	-	L	L	OFF	Lock Mode
H	L		L	L	OFF	
-	-	L	OFF	OFF	OFF	Standby Mode

Application Information

Hall Input

Please adjust hall input voltage by the value of resistance so that hall signal contains amplitude input within the range $GND \sim V_{CC}/3$. The output signal of this IC is the amplified hall input signal, therefore, the output signal depends on hall input. When the hall input is small, the output signal becomes gentle. Oppositely, when the input signal is large, the output becomes steep (See Figure 3. Differences of output signal depending on the shape of hall input signal). The input/output gain is 52dB (typ.). Thus, please adjust the amplitude of the hall input to meet the adequate output voltage.

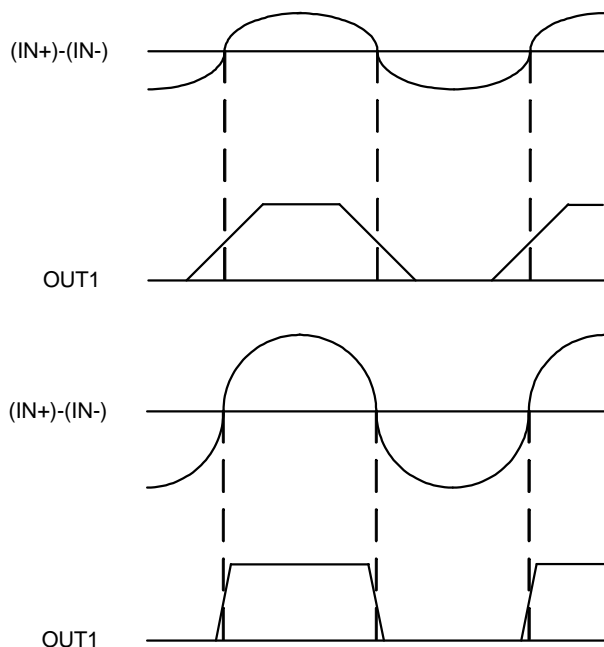

Figure 3. Differences of Output Signal Depending on the Shape of Hall Input Signal

PWM Input

It is possible to change rotation speed of the motor by switching high side output transistor. The on-duty of switching depends on the input signal to the PWM terminal. (See Figure 4. PWM Input Waveform)

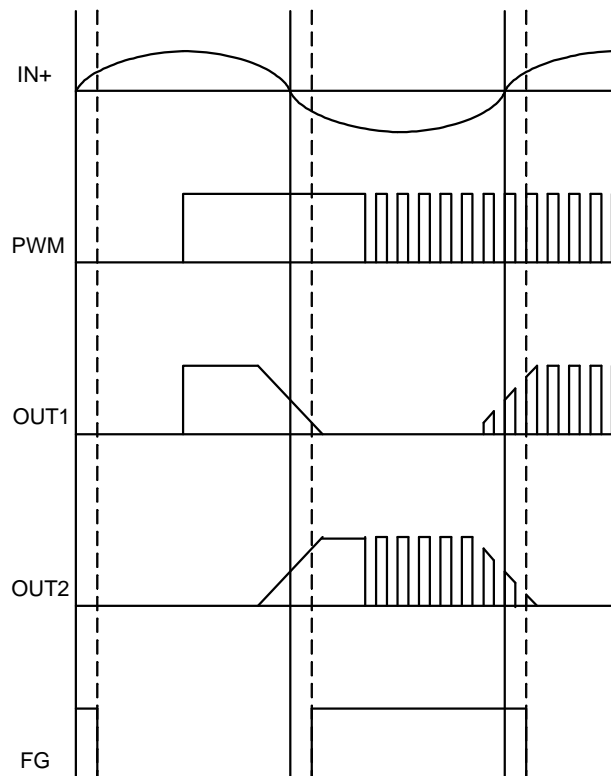

Figure 4. PWM Input Waveform

The input level of PWM terminal is

H : High side output transistor is ON

L : High side output transistor is OFF

When PWM terminal is open, it is equal to H

FG Resistor

The value of the FG resistor could be decided by the following equation:

$$R_{FG} = \frac{V_{CC} - V_{FG}}{I_{FG}}$$

For example:

$$V_{CC} = 12V, I_{FG} = 5mA, V_{FG} = 0.2V, R_{FG} = 2.36k\Omega$$

The value of resistor in the range from 1kΩ to 10kΩ is recommended.

Package Information

MSOP-8

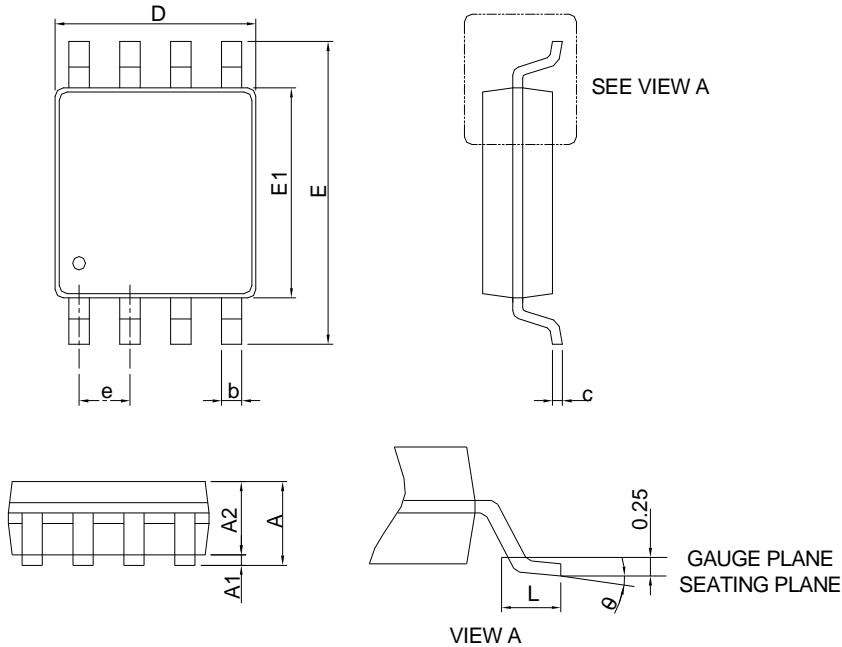

SYMBOL	MSOP-8			
	MILLIMETERS		INCHES	
	MIN.	MAX.	MIN.	MAX.
A		1.10		0.043
A1	0.00	0.15	0.000	0.006
A2	0.75	0.95	0.030	0.037
b	0.22	0.38	0.009	0.015
c	0.08	0.23	0.003	0.009
D	2.90	3.10	0.114	0.122
E	4.70	5.10	0.185	0.201
E1	2.90	3.10	0.114	0.122
e	0.65 BSC		0.026 BSC	
L	0.40	0.80	0.016	0.031
θ	0°	8°	0°	8°

- Note: 1. Follow JEDEC MO-187 AA.
 2. Dimension “D” does not include mold flash, protrusions or gate burrs. Mold flash, protrusion or gate burrs shall not exceed 6 mil per side.
 3. Dimension “E1” does not include inter-lead flash or protrusions. Inter-lead flash and protrusions shall not exceed 5 mil per side.

Package Information

SOP-8

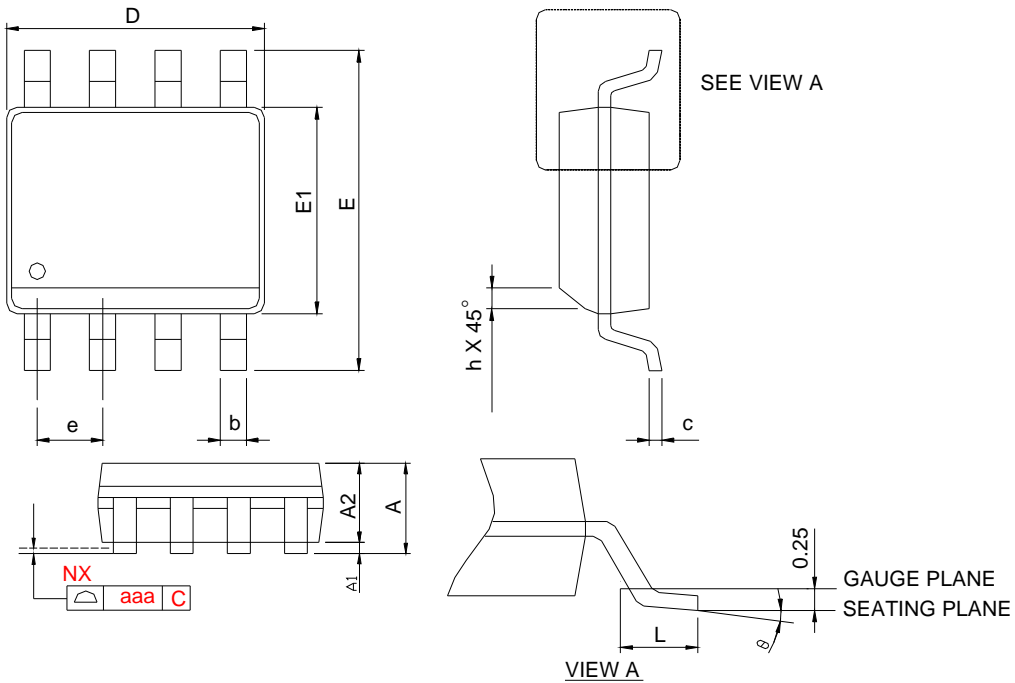

SYMBOL	SOP-8			
	MILLIMETERS		INCHES	
	MIN.	MAX.	MIN.	MAX.
A		1.75		0.069
A1	0.10	0.25	0.004	0.010
A2	1.25		0.049	
b	0.31	0.51	0.012	0.020
c	0.17	0.25	0.007	0.010
D	4.80	5.00	0.189	0.197
E	5.80	6.20	0.228	0.244
E1	3.80	4.00	0.150	0.157
e	1.27 BSC		0.050 BSC	
h	0.25	0.50	0.010	0.020
L	0.40	1.27	0.016	0.050
θ	0°	8°	0°	8°
aaa	0.10		0.004	

- Note: 1. Follow JEDEC MS-012 AA.
 2. Dimension "D" does not include mold flash, protrusions or gate burrs. Mold flash, protrusion or gate burrs shall not exceed 6 mil per side.
 3. Dimension "E" does not include inter-lead flash or protrusions. Inter-lead flash and protrusions shall not exceed 10 mil per side.

Carrier Tape & Reel Dimensions

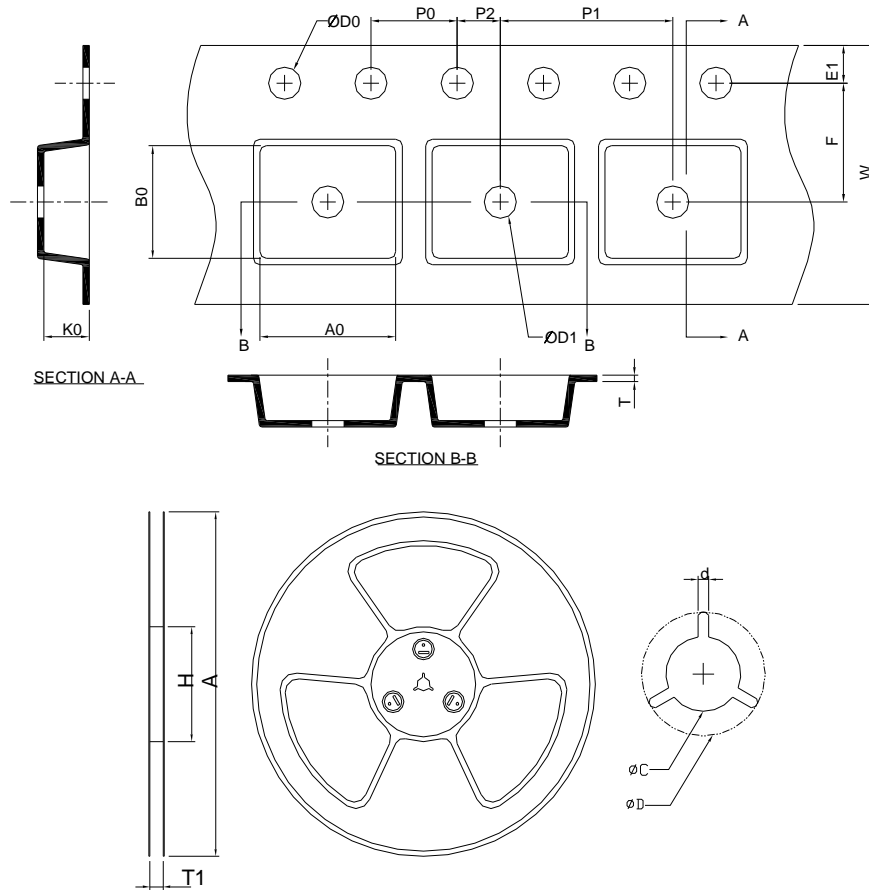

Application	A	H	T1	C	d	D	W	E1	F
MSOP-8	330.0±2.00	50 MIN.	12.4+2.00 -0.00	13.0+0.50 -0.20	1.5 MIN.	20.2 MIN.	12.0±0.30	1.75±0.10	5.5±0.05
	P0	P1	P2	D0	D1	T	A0	B0	K0
	4.00±0.10	8.00±0.10	2.00±0.05	1.5+0.10 -0.00	1.5 MIN.	0.6+0.00 -0.40	5.30±0.20	3.30±0.20	1.40±0.20
Application	A	H	T1	C	d	D	W	E1	F
SOP-8	330.0±2.00	50 MIN.	12.4+2.00 -0.00	13.0+0.50 -0.20	1.5 MIN.	20.2 MIN.	12.0±0.30	1.75±0.10	5.5±0.05
	P0	P1	P2	D0	D1	T	A0	B0	K0
	4.0±0.10	8.0±0.10	2.0±0.05	1.5+0.10 -0.00	1.5 MIN.	0.6+0.00 -0.40	6.40±0.20	5.20±0.20	2.10±0.20

(mm)

Devices Per Unit

Package Type	Unit	Quantity
MSOP-8	Tape & Reel	3000
SOP-8	Tape & Reel	2500

Taping Direction Information

MSOP-8

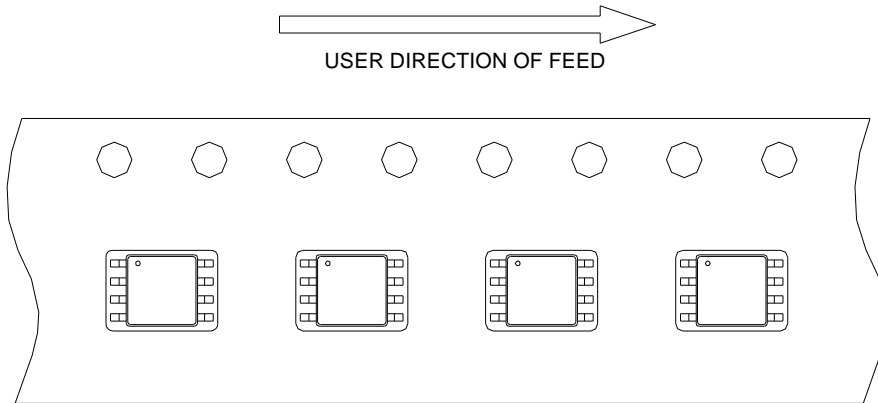

SOP-8

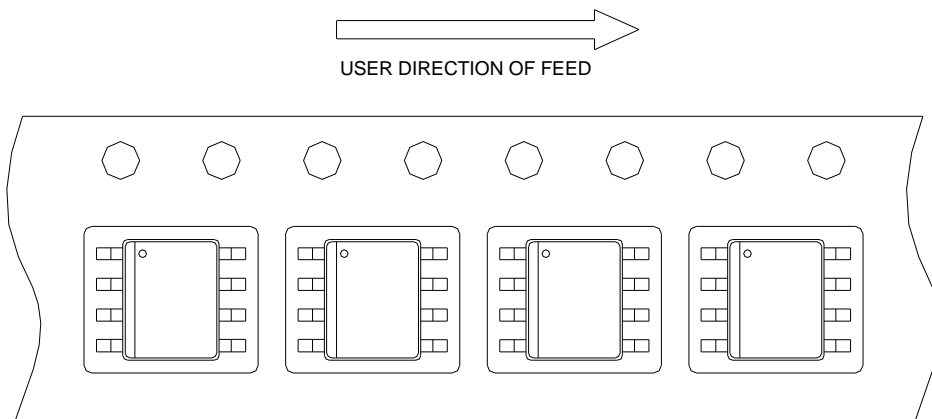

Classification Profile

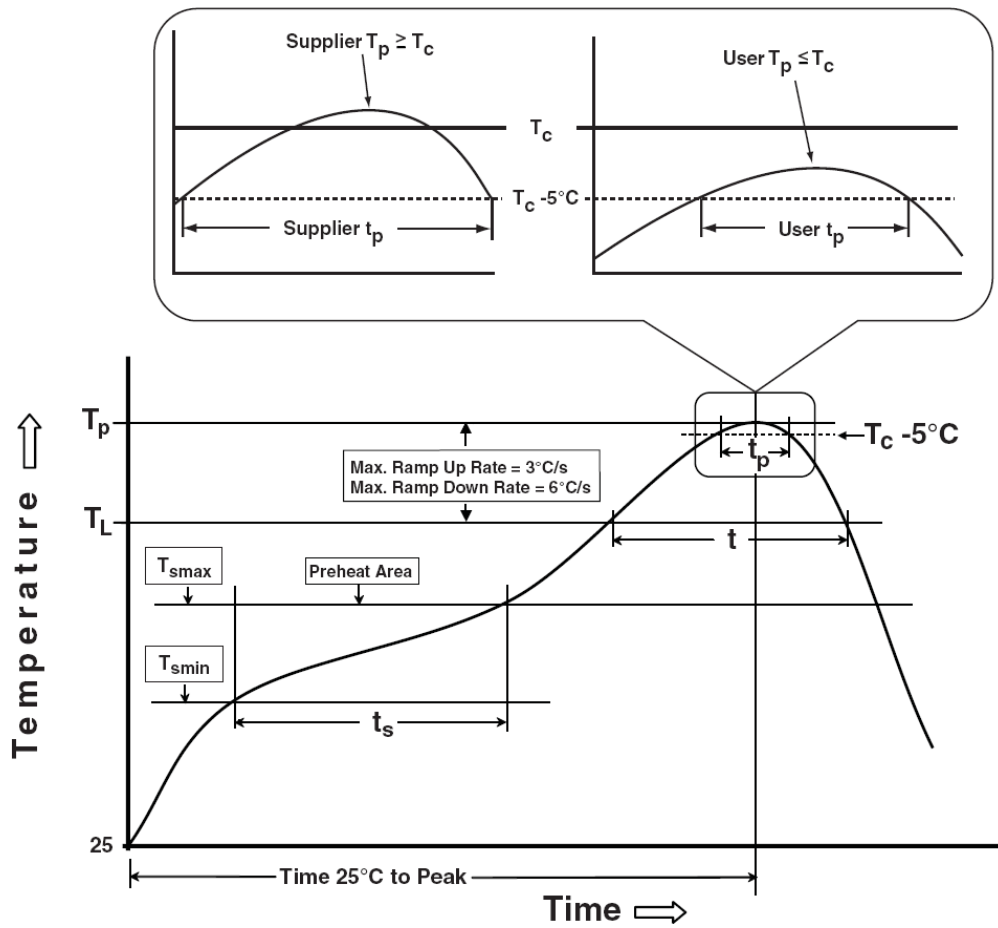

Classification Reflow Profiles

Profile Feature	Sn-Pb Eutectic Assembly	Pb-Free Assembly
Preheat & Soak Temperature min (T_{smin}) Temperature max (T_{smax}) Time (T_{smin} to T_{smax}) (t_s)	100 °C 150 °C 60-120 seconds	150 °C 200 °C 60-120 seconds
Average ramp-up rate (T_{smax} to T_p)	3 °C/second max.	3°C/second max.
Liquidous temperature (T_L) Time at liquidous (t_L)	183 °C 60-150 seconds	217 °C 60-150 seconds
Peak package body Temperature (T_p)*	See Classification Temp in table 1	See Classification Temp in table 2
Time (t_p)** within 5°C of the specified classification temperature (T_c)	20** seconds	30** seconds
Average ramp-down rate (T_p to T_{smax})	6 °C/second max.	6 °C/second max.
Time 25°C to peak temperature	6 minutes max.	8 minutes max.
* Tolerance for peak profile Temperature (T_p) is defined as a supplier minimum and a user maximum. ** Tolerance for time at peak profile temperature (t_p) is defined as a supplier minimum and a user maximum.		

Table 1. SnPb Eutectic Process – Classification Temperatures (T_c)

Package Thickness	Volume mm ³ <350	Volume mm ³ ≥350
<2.5 mm	235 °C	220 °C
≥2.5 mm	220 °C	220 °C

Table 2. Pb-free Process – Classification Temperatures (T_c)

Package Thickness	Volume mm ³ <350	Volume mm ³ 350-2000	Volume mm ³ >2000
<1.6 mm	260 °C	260 °C	260 °C
1.6 mm – 2.5 mm	260 °C	250 °C	245 °C
≥2.5 mm	250 °C	245 °C	245 °C

Reliability Test Program

Test item	Method	Description
SOLDERABILITY	JESD-22, B102	5 Sec, 245°C
HOLT	JESD-22, A108	1000 Hrs, Bias @ $T_j=125^{\circ}C$
PCT	JESD-22, A102	168 Hrs, 100%RH, 2atm, 121°C
TCT	JESD-22, A104	500 Cycles, -65°C~150°C
HBM	MIL-STD-883-3015.7	VHBM ≥ 2KV
MM	JESD-22, A115	VMM ≥ 200V
Latch-Up	JESD 78	10ms, $1_{tr} \geq 100mA$

Customer Service

Anpec Electronics Corp.

Head Office :

No.6, Dusing 1st Road, SBIP,
Hsin-Chu, Taiwan
Tel : 886-3-5642000
Fax : 886-3-5642050

Taipei Branch :

2F, No. 11, Lane 218, Sec 2 Jhongsing Rd.,
Sindian City, Taipei County 23146, Taiwan
Tel : 886-2-2910-3838
Fax : 886-2-2917-3838