

Three-Phase Sensor-Less Fan Motor Driver

Features

- **Three-Phase Full-Wave Sensor-Less Drive Method**
- **Adjustable Forced Commutation Frequency (for Start-up)**
- **Built-In External PWM Speed Control**
- **Built-In Quick Start Function**
- **FG (Rotation Speed Detection) Output (for APX9365D)**
- **RD (Lock Detection) Output (for APX9365E)**
- **1/2FG (Rotation Speed Detection) Output (for APX9365F)**
- **Soft Switching Circuit (for Noise Reducing)**
- **Power Saving Function (PWM Duty Input is 0%)**
- **Built-In Lock Protection and Auto Restart Function**
- **Thermal Shutdown Circuit**
- **Lead Free and Green Devices Available (RoHS Compliant)**

General Description

The APX9365D/E/F provides all the circuitry for sensor-less speed control of three-phase brushless DC motor. The controller functions include start-up circuit, back-EMF commutation control, Pulse Width Modulation (PWM) speed control, lock protection, and thermal shutdown circuit.

The APX9365D/E/F is suitable for both game machine and CPU cooler that need silent drivers. It is available in VTDFN3x3-10 package.

Pin Configuration

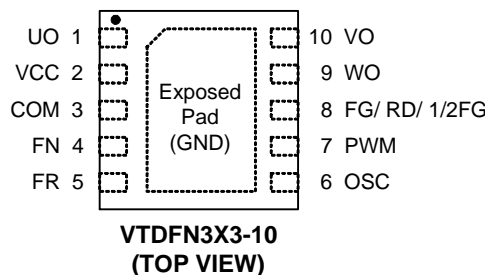

 = Exposed Pad (connected to the ground of power)

Applications

- **Motor Driver For Silent Fan Motors**

Ordering and Marking Information

<p>APX9365D/E/F □□□-□□□</p> <div style="margin-left: 20px;"> <p>└─ Assembly Material</p> <p>└─ Handling Code</p> <p>└─ Temperature Range</p> <p>└─ Package Code</p> </div>	<p>Package Code QF : VTDFN3x3-10</p> <p>Operating Ambient Temperature Range I : -40 to 105 °C</p> <p>Handling Code TR : Tape & Reel</p> <p>Assembly Material G : Halogen and Lead Free Device</p>									
<p>APX9365D/E/F QF :</p> <table style="display: inline-table; border: 1px solid black; text-align: center; margin-right: 10px;"> <tr><td style="padding: 2px;">APX</td></tr> <tr><td style="padding: 2px;">9365D</td></tr> <tr><td style="padding: 2px;">XXXXX</td></tr> </table> <table style="display: inline-table; border: 1px solid black; text-align: center; margin-right: 10px;"> <tr><td style="padding: 2px;">APX</td></tr> <tr><td style="padding: 2px;">9365E</td></tr> <tr><td style="padding: 2px;">XXXXX</td></tr> </table> <table style="display: inline-table; border: 1px solid black; text-align: center;"> <tr><td style="padding: 2px;">APX</td></tr> <tr><td style="padding: 2px;">9365F</td></tr> <tr><td style="padding: 2px;">XXXXX</td></tr> </table>	APX	9365D	XXXXX	APX	9365E	XXXXX	APX	9365F	XXXXX	<p>XXXXX - Date Code</p>
APX										
9365D										
XXXXX										
APX										
9365E										
XXXXX										
APX										
9365F										
XXXXX										

Note: ANPEC lead-free products contain molding compounds/die attach materials and 100% matte tin plate termination finish; which are fully compliant with RoHS. ANPEC lead-free products meet or exceed the lead-free requirements of IPC/JEDEC J-STD-020D for MSL classification at lead-free peak reflow temperature. ANPEC defines "Green" to mean lead-free (RoHS compliant) and halogen free (Br or Cl does not exceed 900ppm by weight in homogeneous material and total of Br and Cl does not exceed 1500ppm by weight).

ANPEC reserves the right to make changes to improve reliability or manufacturability without notice, and advise customers to obtain the latest version of relevant information to verify before placing orders.

Absolute Maximum Ratings (Note 1)

Symbol	Parameter	Rating	Unit
V _{CC}	VCC Pin Supply Voltage	-0.3 to 7	V
I _{OUT}	UO/VO/WO Pin Output Current	0 to 1	A
V _{UO/V_{VO}/V_{WO}}	UO/VO/WO Pin Output Voltage	-0.3 to 7	V
V _{FG/RD}	FG/RD Pin Output Voltage	-0.3 to 7	V
I _{FG/RD}	FG/RD Pin Sink Current	0 to 10	mA
V _{FR}	FR Pin Input Voltage	-0.3 to 7	V
T _J	Junction Temperature	-40 to 150	°C
T _{STG}	Storage Temperature	-65 to 150	°C
T _{SDR}	Maximum Lead Soldering Temperature, 10 Seconds	260	°C

Note1: Stresses beyond those listed under "absolute maximum ratings" may cause permanent damage to the device. These are stress ratings only and functional operation of the device at these or any other conditions beyond those indicated under "recommended operating conditions" is not implied. Exposure to absolute maximum rating conditions for extended periods may affect device reliability.

Thermal Characteristics

Symbol	Parameter	Typical Value	Unit
θ _{JA}	Thermal Resistance-Junction to Ambient ^(Note2) VTDFN3x3-10	119	°C/W
P _D	Power Dissipation, T _A =25°C VTDFN3x3-10	1.05	W

Note 2: θ_{JA} is measured with the component mounted on a 55mm x 40mm x 1.6mm glass epoxy board (two-layer) in free air.

Recommended Operating Conditions

Symbol	Parameter	Range	Unit
V _{CC}	VCC Pin Supply Voltage Range	1.8 to 6	V
V _{PWM}	PWM Pin Input Voltage Range	0 to V _{CC}	V
T _A	Ambient Temperature	-40 to 105	°C
I _{OUT}	UO/VO/WO Pin Average Output Current	0 to 400	mA

Electrical Characteristics (V_{CC}=5V, T_A=25°C, unless otherwise specified)

Symbol	Parameter	Test Conditions	APX9365D/E/F			Unit
			Min.	Typ.	Max.	
SUPPLY CURRENT						
I _{CC1}	Operating Current	Rotation Mode	-	3	5	mA
I _{CC2}	Standby Supply Current	PWM=0	-	100	150	µA
PWM INPUT						
V _{PWMH}	PWM Input High Level Voltage		2.5	-	V _{CC} +0.5	V
V _{PWML}	PWM Input Low Level Voltage		0	-	1	V
F _{PWM}	PWM Input Frequency		15	-	50	kHz
OUTPUT DRIVERS						
V _O	Output Driver Saturation Voltage	I _{OUT} =250mA, Upper and Lower total	-	0.3	0.44	V

Electrical Characteristics (Cont.) ($V_{CC}=5V$, $T_A=25^{\circ}C$, unless otherwise specified)

Symbol	Parameter	Test Conditions	APX9365D/E/F			Unit
			Min.	Typ.	Max.	
OUTPUT DRIVERS (CONT.)						
$V_{FG/RD}$	FG/RD Pin Low Voltage	$I_{FG/RD}=5mA$	-	0.2	0.3	V
$I_{FGL/RDL}$	FG/RD Pin Leak Current	$V_{FG/RD}=7V$	-	-	10	μA
V_{FR}	FR Pin Input Threshold Voltage		-	$0.5 \times V_{CC}$	-	V
LOCK PROTECTION						
T_{ON}	Lock Detection On Time		0.85	1	1.15	sec
T_{OFF}	Lock Detection Off Time		4.25	5	5.75	sec
THERMAL SHUTDOWN						
OTS	Over Temperature Shutdown		-	160	-	$^{\circ}C$
	Over Temperature Shutdown Hysteresis		-	30	-	
QUICK START						
T_{QS}	Quick Start Enable Time		-	2	-	ms
T_{MIN}	PWM minimum on time	Standby Mode enable ^(Note3)	-	-	1	μs

Note 3: Be sure PWM on pulse width less than $1\mu s$ if stand by mode enabled.

Typical Operating Characteristics

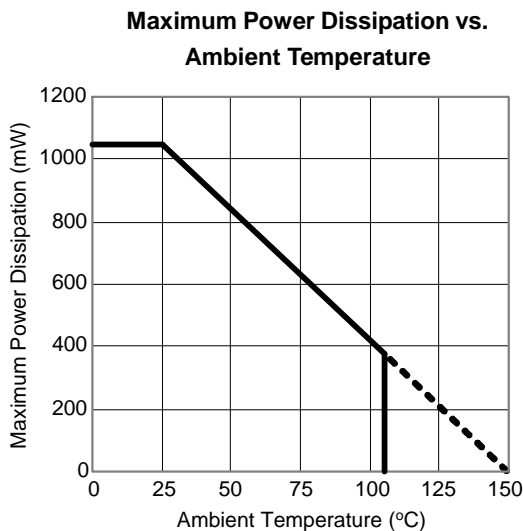
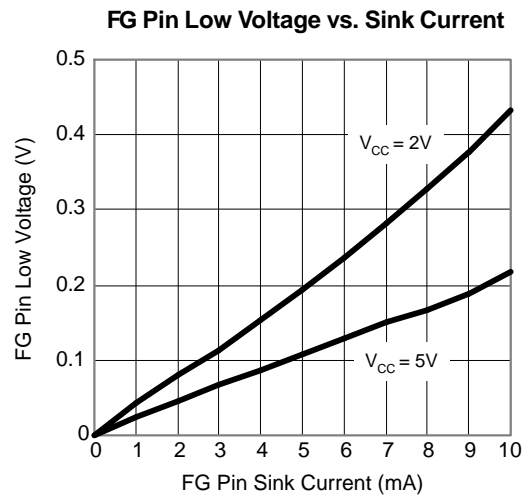
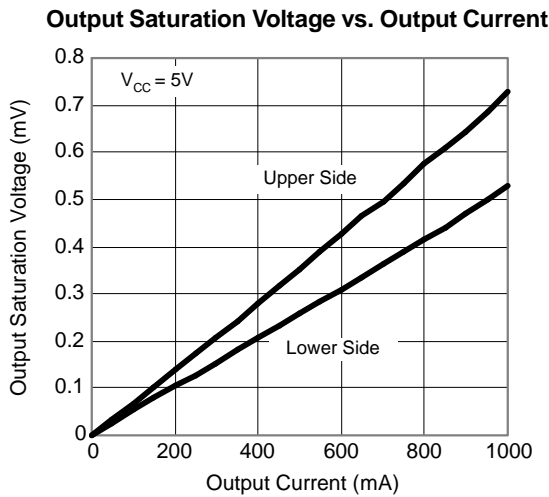
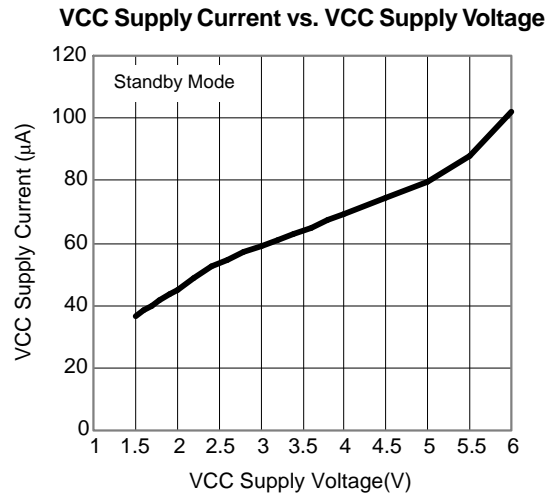
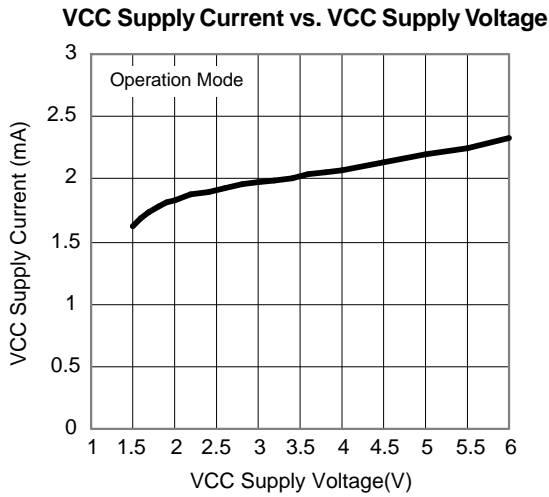

Operating Waveforms

Rotation Mode Waveform (NORMAL)

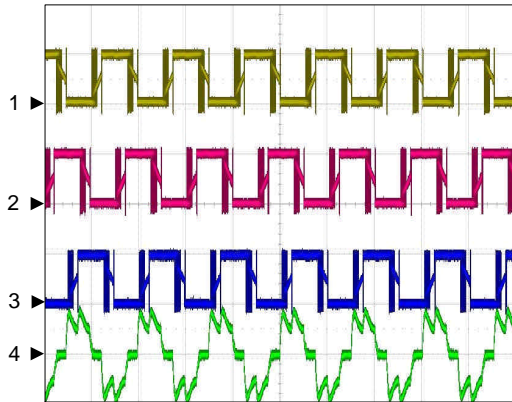

CH1: V_{UO} , 5V/div, DC
 CH2: V_{VO} , 5V/div, DC
 CH3: V_{WO} , 5V/div, DC
 CH4: I_{UO} , 200mA/div, DC
 Time: 5ms/div

Rotation Mode Waveform (PWM)

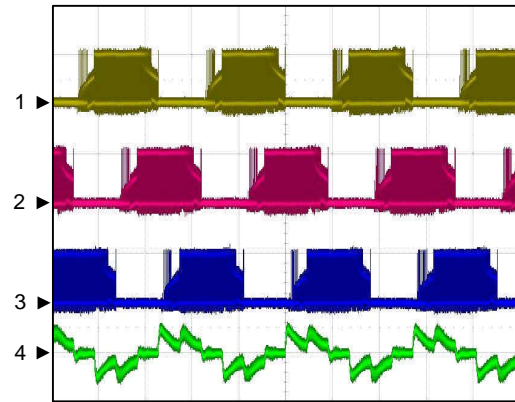

CH1: V_{UO} , 5V/div, DC
 CH2: V_{VO} , 5V/div, DC
 CH3: V_{WO} , 5V/div, DC
 CH4: I_{UO} , 200mA/div, DC
 Time: 5ms/div

Lock Protection Waveform (Lock)

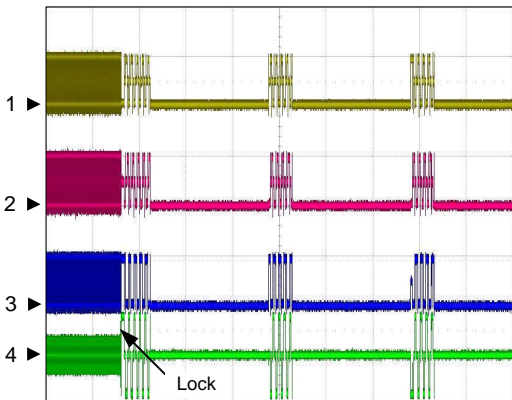

CH1: V_{UO} , 5V/div, DC
 CH2: V_{VO} , 5V/div, DC
 CH3: V_{WO} , 5V/div, DC
 CH4: I_{UO} , 500mA/div, DC
 Time: 2s/div

Lock Protection Waveform (Release)

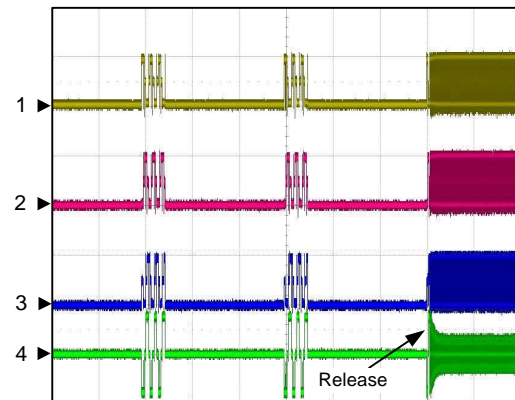

CH1: V_{UO} , 5V/div, DC
 CH2: V_{VO} , 5V/div, DC
 CH3: V_{WO} , 5V/div, DC
 CH4: I_{UO} , 500mA/div, DC
 Time: 2s/div

Pin Description

PIN		FUNCTION
NO.	NAME	
1	UO	Driver Output Pin. Output signal for driving motor phase U.
2	VCC	Supply Voltage Input Pin.
3	COM	Motor Neutral Point Input Pin
4	FN	Motor Floating Terminal Voltage Output.
5	FR	Motor Spin Direction Control Pin. High Level Input: U → V → W Low Level Input: U → W → V
6	OSC	Start-up Commutation Time Setting. Connect a capacitor to GND to set start-up commutation time.
7	PWM	PWM Signal Input Pin. Input PWM signal to control rotation speed.
8	FG(APX9365D)	Rotation Speed Output. This is an open-drain output.
	RD(APX9365E)	Rotation Detection Output. This is an open-drain output.
	1/2FG(APX9365F)	Rotation Speed Output. This is an open-drain output.
9	WO	Driver Output Pin. Output signal for driving motor phase W.
10	VO	Driver Output Pin. Output signal for driving motor phase V.
Exposed Pad	GND	Ground Pin.

Block Diagram

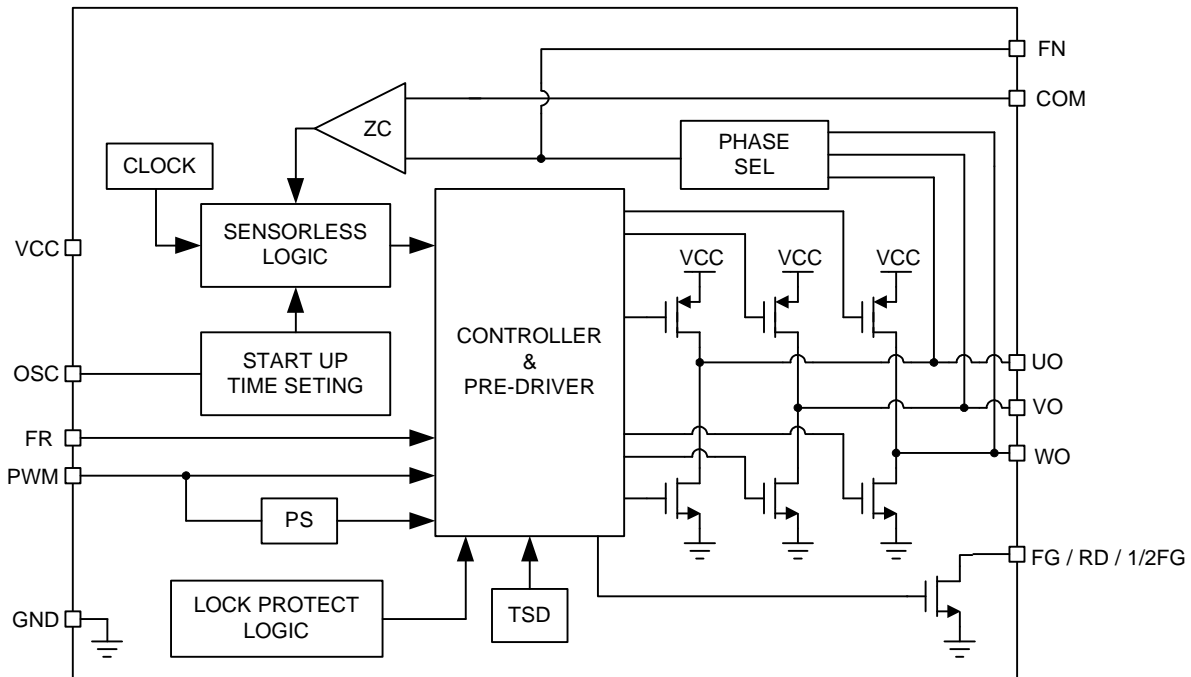

Typical Application Circuit

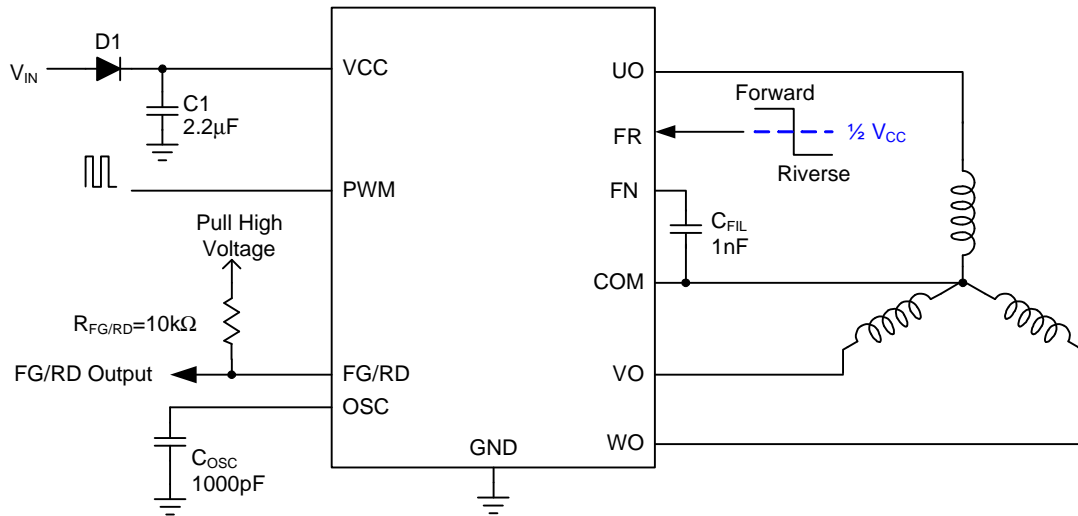

Note : D1 is to prevent the damage from the power reverse connection.

Function Description

PWM Speed Control

It is possible to change rotation speed of the motor by switching high side output transistor. The on-duty of switching depends on the signal from input to PWM terminal. (See Figure 1 PWM Input Waveform)

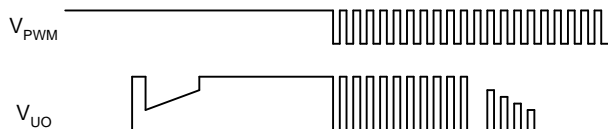

Figure 1. PWM Input Waveform

Quick Start

This IC disables the lock protection function when the PWM input keeps low level for more than 2ms. (See Figure 2 Quick Start Waveform)

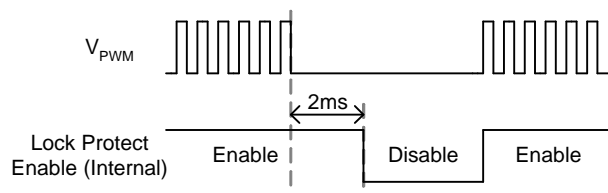

Figure 2. Quick Start Waveform

FG Output

The FG pin is an open-drain output, connecting a pull up resistor to a high level voltage for the speed detection function. When UO pin voltage switches to high, the FG is high (switch off) and the UO pin voltage switches to low then FG is low (switch on). The FG output only works in sensor-less mode. (See Figure 3 FG Output Waveform)

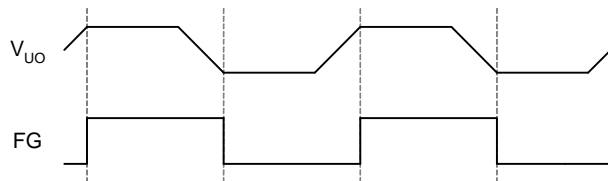

Figure 3. FG Output Waveform

Soft Switch

The APX9365D/E/F is equipped with a soft switch function to make phase current become more gentle, which can reduce the noise of motor in switching interval.

Lock Protection and Automatic Restart

The APX9365D/E/F provides the lock protection and automatic restart functions to prevent the coil burnout while the fan is locked. As the fan is locked, the IC will come into start-up operation for 1 second. Then, the IC will switch to lock protection mode to close output driver for 6 seconds. After lock protection mode, the IC switches to start-up operation again. If the locked condition still remains, the lock-and-restart process will be recurred until the locked condition is released.

Thermal Protection

The APX9365D/E/F has thermal protection. When internal junction temperature reaches 160°C, the output devices will be switched off. When the IC's junction temperature cools down 30°C, the thermal sensor will turn on the output devices again, resulting in a pulsed output during continuous thermal protection.

Application Information

Input Protection Diode & Capacitor

It is necessary to add a protection diode (D1) to prevent the damage from the power reverse connection. However, the protection diode will cause a voltage drop on the supply voltage. The current rating of the diode must be larger than the maximum output current. For the noise reduction purpose, a capacitor (C1) is connected between VCC and GND. (see Typical Application Circuit) It's suggested that C1 should be placed as close as possible in the VCC pin.

OSC Capacitor

The capacitor connects from OSC pin to GND can be determined the frequency of force commutation. The optimal design of the frequency could make sure the motor start-up in succeed. Its capacitance from 1000pF to 3300pF is recommended.

FIL Capacitor

The capacitor connects between FN and COM pin to filter the noise when phase change to make sure phase change correctly. Its capacitance from 10nF to 100nF is recommended.

FG/RD Resistor

The value of FG/RD resistor could be decided by the following equation:

$$R_{FG/RD} = \frac{V_{CC} - V_{FG/RD}}{I_{FG/RD}}$$

For example:

$$V_{CC} = 5V, I_{FG/RD} = 5mA, V_{FG/RD} = 0.2V, R_{FG/RD} = 0.96k\Omega$$

The value of resistor in the range of 1k Ω to 10k Ω is recommended.

Thermal Consideration

Refer to "Maximum Power Dissipation vs. Ambient Temperature", the IC is safe to operate below the curve and it will cause the thermal protection if the operating area is above the line. For example, $T_A = 75^\circ\text{C}$, the MSOP-10 package maximum power dissipation is about 0.48W. The power dissipation can be calculated by the following equation:

$$P_D = (V_{CC} - |V_{UO} - V_{VO}|) \times I_{UO} + V_{CC} \times I_{CC}$$

For example:

$$V_{CC} = 5V, I_{CC} = 3mA, I_{OUT} = 250mA, V_{UO} = 4.85V,$$

$$V_{VO} = 0.15V, \text{ then } P_D = 0.09W$$

The GND pin provides an electrical connection to the ground and channeling heat away. The printed circuit board (PCB) forms a heat sink and dissipates most of the heat into ambient air.

Package Information

VTDFN3x3-10

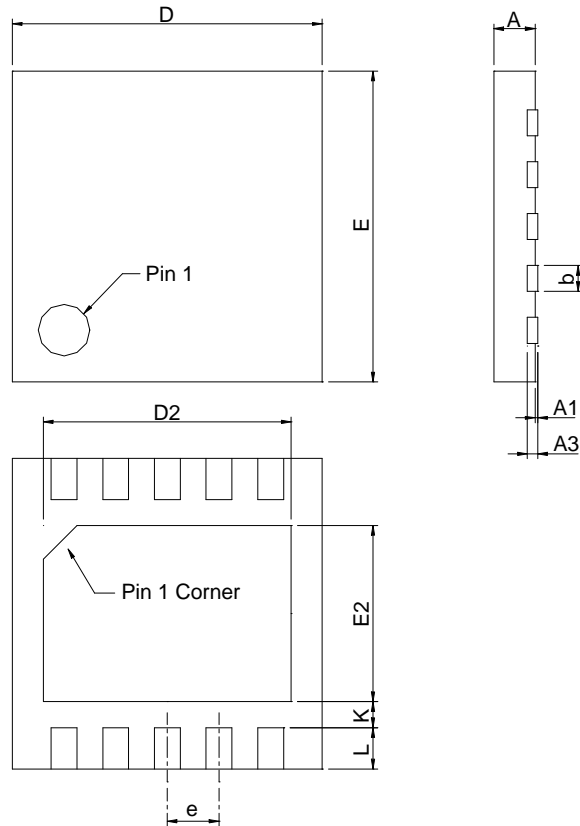

SYMBOL	VTDFN3x3-10			
	MILLIMETERS		INCHES	
	MIN.	MAX.	MIN.	MAX.
A	0.50	0.60	0.020	0.024
A1	0.00	0.05	0.000	0.002
A3	0.20 REF		0.008 REF	
b	0.18	0.30	0.007	0.012
D	2.90	3.10	0.114	0.122
D2	2.20	2.70	0.087	0.106
E	2.90	3.10	0.114	0.122
E2	1.40	1.75	0.055	0.069
e	0.50 BSC		0.016 BSC	
L	0.30	0.50	0.012	0.020
K	0.20		0.008	

Carrier Tape & Reel Dimensions

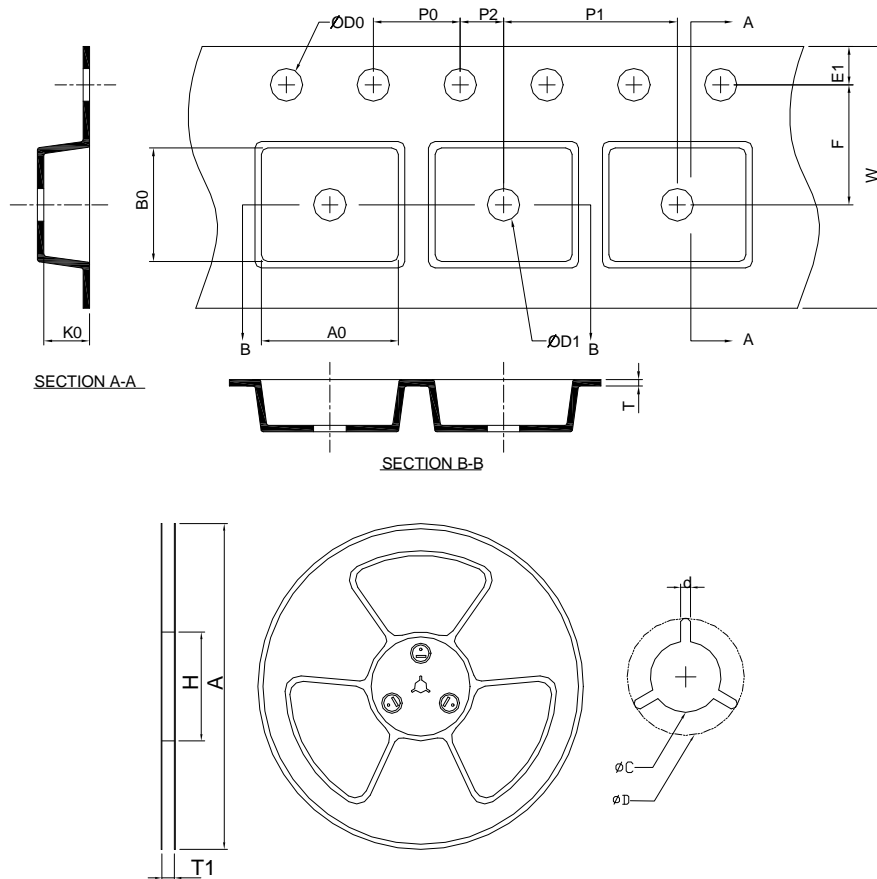

Application	A	H	T1	C	d	D	W	E1	F
VTDFN3x3-10	330.0 ±2.00	50 MIN.	12.4+2.00 -0.00	13.0+0.50 -0.20	1.5 MIN.	20.2 MIN.	12.0 ±0.30	1.75 ±0.10	5.5 ±0.05
	P0	P1	P2	D0	D1	T	A0	B0	K0
	4.0 ±0.10	8.0 ±0.10	2.0 ±0.05	1.5+0.10 -0.00	1.5 MIN.	0.6+0.00 -0.40	3.30 ±0.20	3.30 ±0.20	1.30 ±0.20

(mm)

Devices Per Unit

Package Type	Unit	Quantity
VTDFN3x3-10	Tape & Reel	3000

Taping Direction Information

VTFDN3x3-10

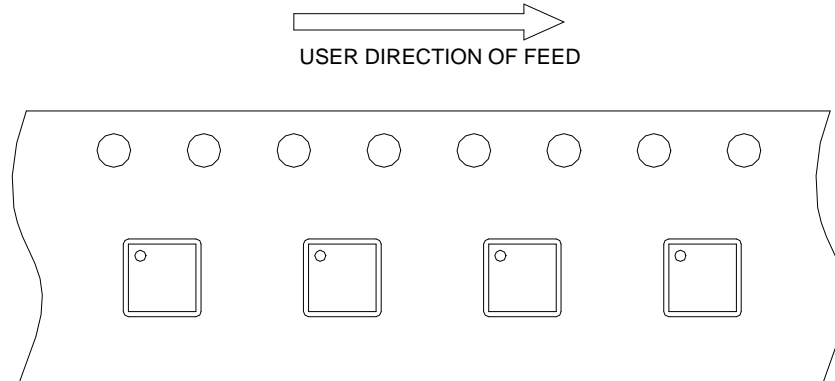

Classification Profile

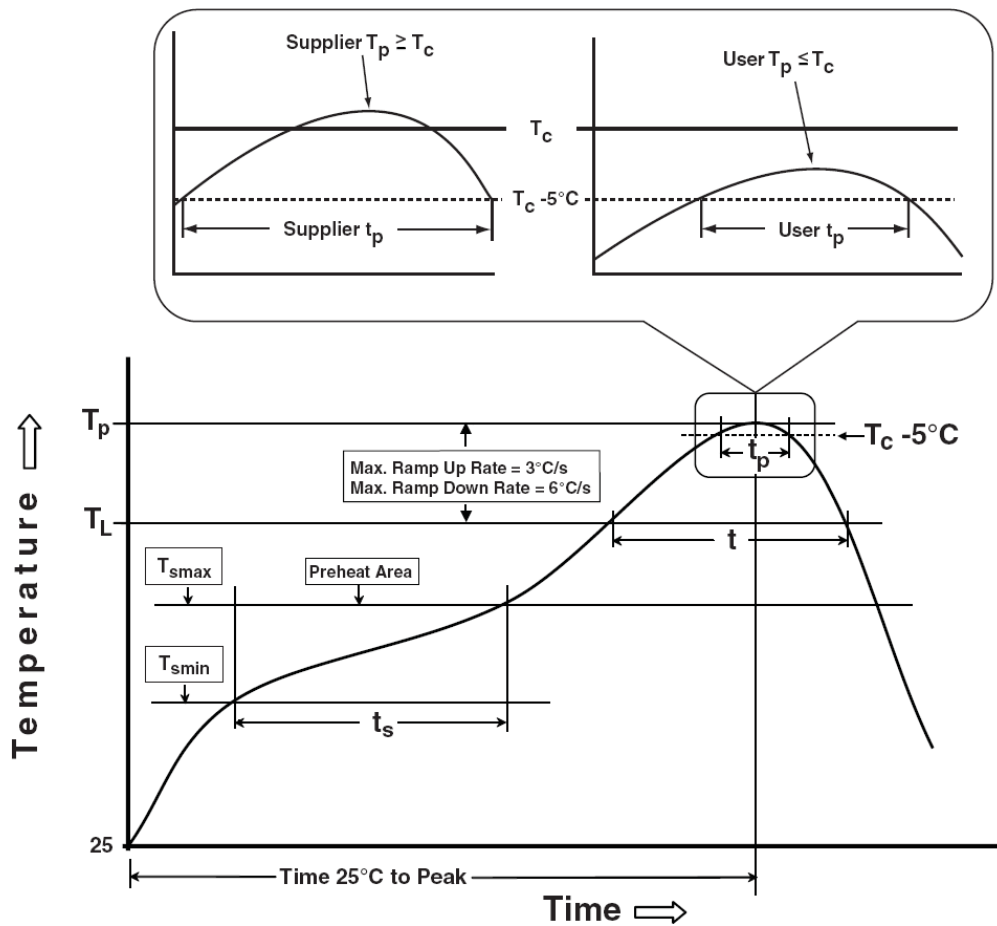

Classification Reflow Profiles

Profile Feature	Sn-Pb Eutectic Assembly	Pb-Free Assembly
Preheat & Soak Temperature min (T_{smin}) Temperature max (T_{smax}) Time (T_{smin} to T_{smax}) (t_s)	100 °C 150 °C 60-120 seconds	150 °C 200 °C 60-120 seconds
Average ramp-up rate (T_{smax} to T_p)	3 °C/second max.	3°C/second max.
Liquidous temperature (T_L) Time at liquidous (t_L)	183 °C 60-150 seconds	217 °C 60-150 seconds
Peak package body Temperature (T_p)*	See Classification Temp in table 1	See Classification Temp in table 2
Time (t_p)** within 5°C of the specified classification temperature (T_c)	20** seconds	30** seconds
Average ramp-down rate (T_p to T_{smax})	6 °C/second max.	6 °C/second max.
Time 25°C to peak temperature	6 minutes max.	8 minutes max.
* Tolerance for peak profile Temperature (T_p) is defined as a supplier minimum and a user maximum. ** Tolerance for time at peak profile temperature (t_p) is defined as a supplier minimum and a user maximum.		

Table 1. SnPb Eutectic Process – Classification Temperatures (T_c)

Package Thickness	Volume mm ³ <350	Volume mm ³ ≥350
<2.5 mm	235 °C	220 °C
≥2.5 mm	220 °C	220 °C

Table 2. Pb-free Process – Classification Temperatures (T_c)

Package Thickness	Volume mm ³ <350	Volume mm ³ 350-2000	Volume mm ³ >2000
<1.6 mm	260 °C	260 °C	260 °C
1.6 mm – 2.5 mm	260 °C	250 °C	245 °C
≥2.5 mm	250 °C	245 °C	245 °C

Reliability Test Program

Test item	Method	Description
SOLDERABILITY	JESD-22, B102	5 Sec, 245°C
HOLT	JESD-22, A108	1000 Hrs, Bias @ $T_j=125^\circ\text{C}$
PCT	JESD-22, A102	168 Hrs, 100%RH, 2atm, 121°C
TCT	JESD-22, A104	500 Cycles, -65°C~150°C
HBM	MIL-STD-883-3015.7	VHBM 2KV
MM	JESD-22, A115	VMM 200V
Latch-Up	JESD 78	10ms, 1 _{tr} 100mA

Customer Service

Anpec Electronics Corp.

Head Office :

No.6, Dusing 1st Road, SBIP,
Hsin-Chu, Taiwan
Tel : 886-3-5642000
Fax : 886-3-5642050

Taipei Branch :

2F, No. 11, Lane 218, Sec 2 Jhongsing Rd.,
Sindian City, Taipei County 23146, Taiwan
Tel : 886-2-2910-3838
Fax : 886-2-2917-3838