

Description

The AR0532P6 is a bi-directional TVS diode, utilizing leading monolithic silicon technology to provide fast response time and low ESD clamping voltage, making this device an ideal solution for protecting voltage sensitive high-speed data lines. The AR0532P6 has an ultra-low capacitance with a typical value at 0.3pF, and complies with the IEC 61000-4-2 (ESD) with $\pm 25\text{kV}$ air and $\pm 25\text{kV}$ contact discharge. It is assembled into an ultra-small 1.6x1.0x0.75mm lead-free DFN package. The small size, ultra-low capacitance and high ESD surge protection make AR0532P6 an ideal choice to protect cell phone, digital video interfaces and other high speed ports.

Features

- Ultra small package: 1.6x1.0x0.75mm
- Ultra low capacitance: 0.3pF typical
- Ultra low leakage: nA level
- Operating voltage: 5V
- Low clamping voltage
- Complies with following standards:
 - IEC 61000-4-2 (ESD) immunity test
 - Air discharge: $\pm 25\text{kV}$
 - Contact discharge: $\pm 25\text{kV}$
 - IEC61000-4-5 (Lightning) 8A (8/20 μs)
- RoHS Compliant

Dimensions and Pin Configuration

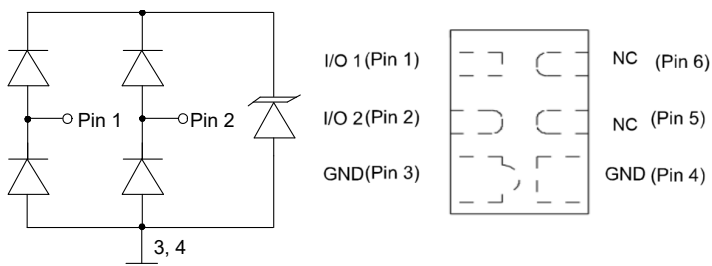

Circuit Schematic

PIN Schematic

Mechanical Characteristics

- Package: DFN1610-6
- Case Material: "Green" Molding Compound.
- Moisture Sensitivity: Level 3 per J-STD-020
- Terminal Connections: See Diagram Below
- Marking Information: See Below

Applications

- Cellular Handsets and Accessories
- Display Ports
- MDDI Ports
- USB Ports
- Digital Visual Interface (DVI)
- PCI Express and Serial SATA Ports

Marking Information



0532P = Device Marking Code

Dot denotes Pin1

Ordering Information

Part Number	Packaging	Reel Size
AR0532P6	3000/Tape & Reel	7 inch

Absolute Maximum Ratings (T_A=25°C unless otherwise specified)

Parameter	Symbol	Value	Unit
Peak Pulse Power (8/20μs)	Ppk	160	W
Peak Pulse Current (8/20μs)	I _{PP}	8	A
ESD per IEC 61000-4-2 (Air) ESD per IEC 61000-4-2 (Contact)	V _{ESD}	±25 ±25	kV
Operating Temperature Range	T _J	-55 to +125	°C
Storage Temperature Range	T _{stg}	-55 to +150	°C

Electrical Characteristics (T_A=25°C unless otherwise specified)

Parameter	Symbol	Min	Typ	Max	Unit	Test Condition
Reverse Working Voltage	V _{RWM}		3.3	5	V	
Breakdown Voltage	V _{BR}	6.5		9.5	V	I _T = 1mA
Reverse Leakage Current	I _R			0.05	μA	V _{RWM} = 3.3V
Reverse Leakage Current	I _R			0.2	μA	V _{RWM} = 5V
Clamping Voltage	V _C			12	V	I _{PP} = 1A (8 x 20μs pulse)
Clamping Voltage	V _C			20	V	I _{PP} = 8A (8 x 20μs pulse)
Junction Capacitance	C _J		0.3	0.4	pF	V _R = 0V, f = 1MHz, Pin 1 to Pin 2

Typical Performance Characteristics (TA=25°C unless otherwise Specified)

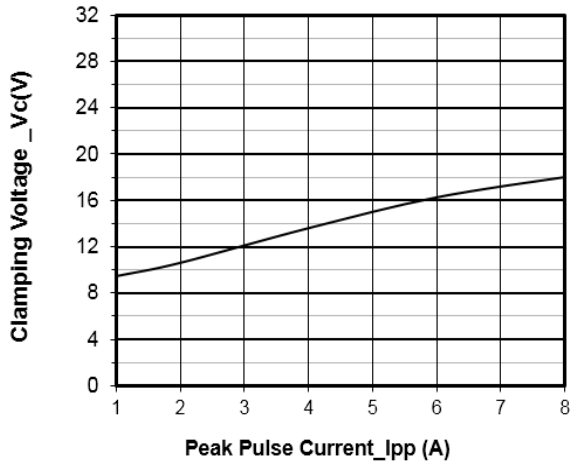

Junction Capacitance vs. Reverse Voltage

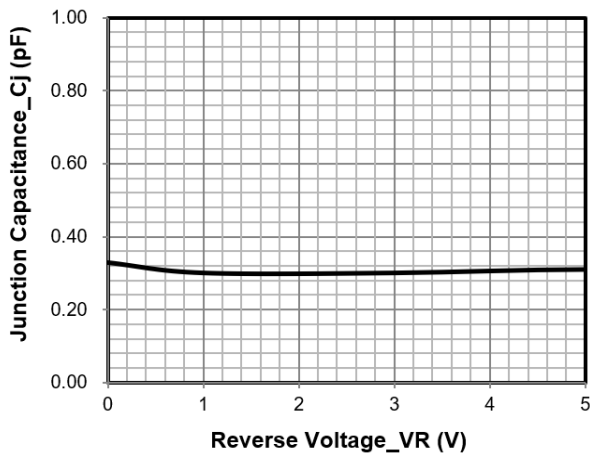

Clamping Voltage vs. Peak Pulse Current

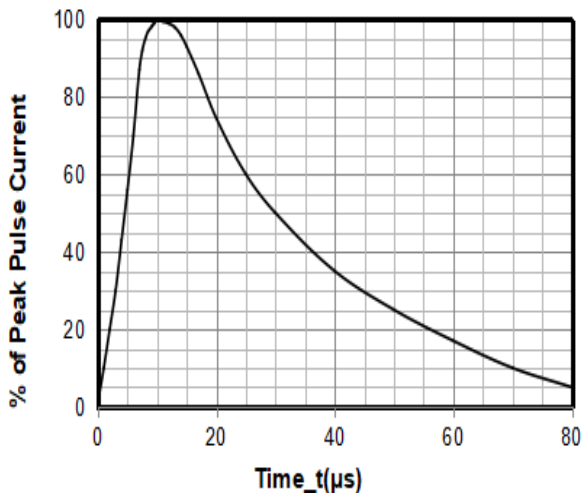

8 X 20μs Pulse Waveform

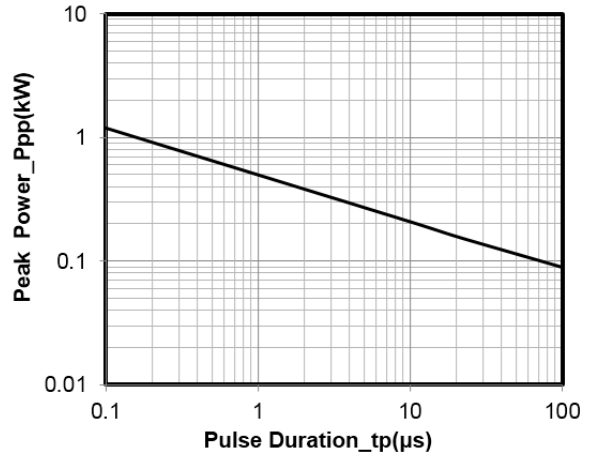

Peak Pulse Power vs. Pulse Time

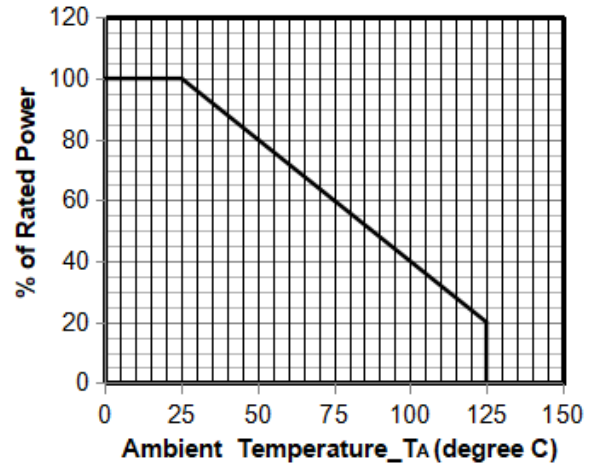

Power Derating Curve

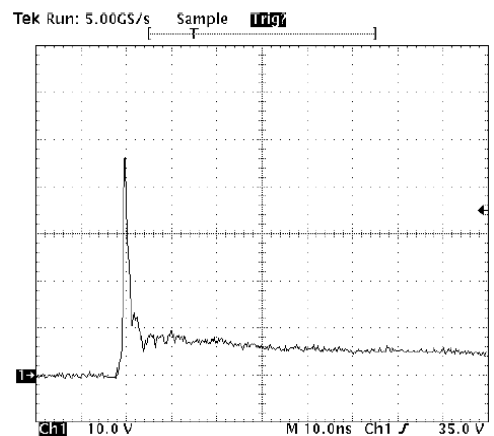

Note: Data is taken with a 10x attenuator

ESD Clamping Voltage

8 kV Contact per IEC61000-4-2

DFN1610-6 Package Outline Drawing

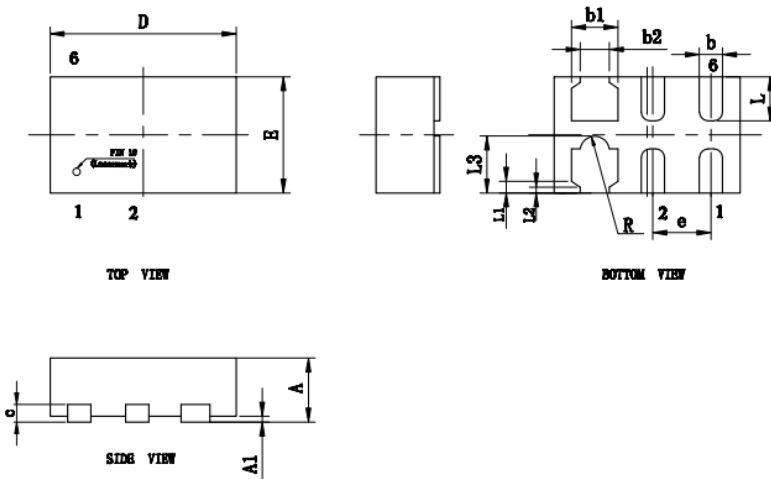

SYM	MILLIMETERS		
	MIN	NOM	MAX
A	0.50	0.55	0.60
A1	--	0.02	0.05
b	0.15	0.20	0.25
b1	0.35	0.40	0.45
b2	0.20	0.25	0.30
c	0.10	0.15	0.20
D	1.55	1.60	1.65
E	0.95	1.00	1.05
e	0.50BSC		
L	0.33	0.38	0.43
L1	0.100REF		
L2	0.05REF		
L3	0.49REF		
R	0.08	0.13	0.18

Suggested Land Pattern

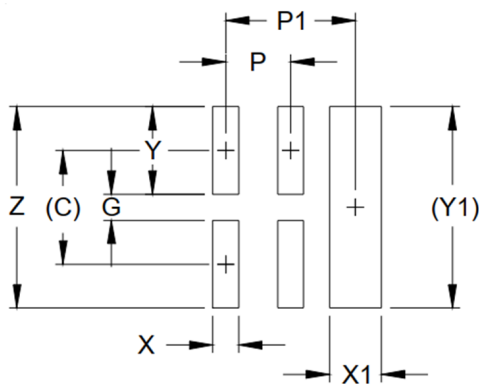

DIMENSIONS		
DIM	INCHES	MILLIMETERS
C	(.034)	(0.87)
G	.007	0.19
P	.020	0.50
P1	.039	1.00
X	.008	0.20
X1	.016	0.40
Y	.027	0.68
Y1	(.061)	(1.55)
Z	.061	1.55

Contact Information

Applied Power Microelectronics Co., Ltd.

Website: <http://www.appliedpowermicro.com>

Email: sales@appliedpowermicro.com

Phone: +86 (0519) 8399 3606