



Eval Kit Manual

AS6200 AS6200C

Adapter Board

AS6200-WL_EK_A

AS6200C-WL_EK_AB

Content Guide

1	Introduction	3
1.1	Kit Content	3
2	Getting Started	4
3	Hardware Description.....	4
3.1	Hardware Architecture	4
3.2	AS6200 Configuration	5
3.3	Power Supply and Connections.....	5
4	Software Description	6
4.1	Index Register	6
4.2	Temperature Register	7
5	Schematics, Layers and BOM	8
5.1	Schematics.....	8
5.2	Layout and Board Dimensions.....	9
5.3	Bill of Materials	10
6	Copyrights & Disclaimer.....	12
7	Revision Information	13

1 Introduction

The AS6200 and AS6200C adapter boards are a small PCB allowing a simple and quick evaluation of the AS6200 and AS6200C digital temperature sensors without the need to design a custom PCB. This small form factor board is fully assembled with the AS6200/C temperature sensor and its necessary external components.

1.1 Kit Content

This kit contains following material listed in

Table 1: Kit Content.

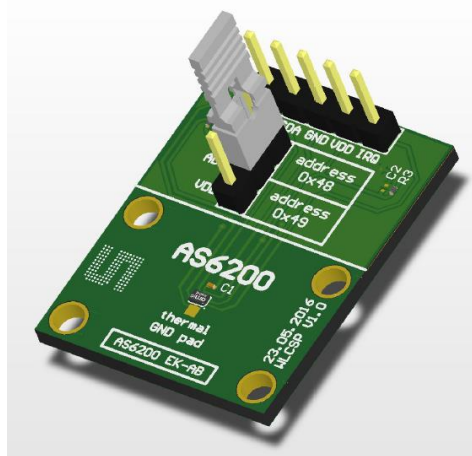

Figure 1: adapter board

Pos.	Item	Comment
1	AS6200-EK-AB or AS6200C-EK-AB	Eval kit adapter board

Table 1: Kit Content

2 Getting Started

The AS6200/C adapter board is ideal for rapid setup of a digital temperature sensor. To get started connect the board to your microcontroller configuration as described in *Figure 3: I²C connection*. Add a command in your source code to request two bytes from the selected I²C address. Finally convert the returned data as described in chapter 4.2 *Temperature Register* to get the actual temperature value.

3 Hardware Description

The P1 connector does provide all relevant signals which can be easily wired to a microcontroller and power supplied with a voltage of 1.8 to 3.6V

Pin	Symbol	Description	Info
1	SCL	I ² C clock	Use R1 if pull-up is required
2	SDA	I ² C data	Use R2 if pull-up is required
3	GND	Ground	
4	VDD	Power supply	1,8 – 3,6 V
5	IRQ	Digital output pin	Alert interrupt output

Table 2 Adapter board pin-out

3.1 Hardware Architecture

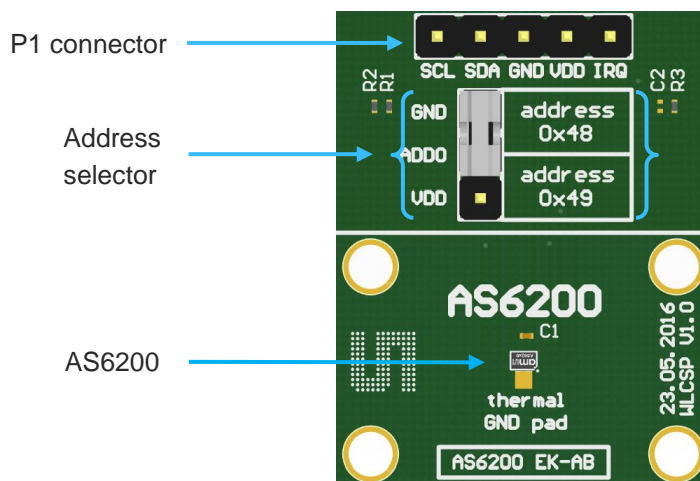

Figure 2: AS6200 adapter board

R1, R2 and R3 are pull-up resistors for the I²C interface and the Alert pin.

Depending on the application, it is recommended to either populate the decoupling capacitor C1 or C2.

3.2 AS6200/C Configuration

With the address selector, it is possible to choose the I²C address of the device. The included jumper is an easy way of setting the I²C address of the sensor. The address selector must not be left open.

	Address Selector	Device Address
<p>Diagram showing the address selector jumper connected to the GND pin. The jumper is positioned over the 'address 0x48' pin.</p>	GND	100 1000 0x48
<p>Diagram showing the address selector jumper connected to the VDD pin. The jumper is positioned over the 'address 0x49' pin.</p>	VDD	100 1001 0x49

Table 3: I²C address

3.3 Power Supply and Connections

The PCB has to be connected to an external microcontroller. P1 is populated with a 1x5 pin header and is required for power supply as well as I²C communication. In addition to that it can be used to monitor the interrupt status via pin 5 (IRQ).

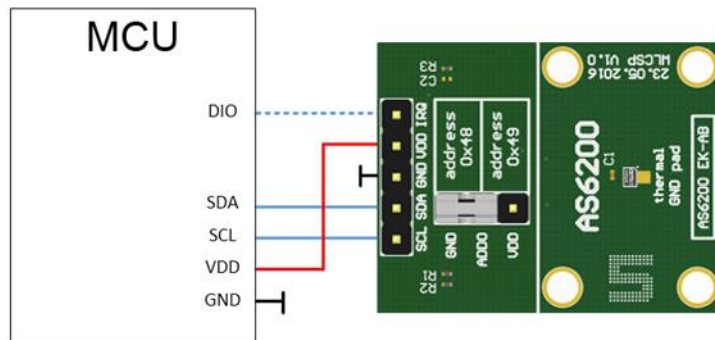
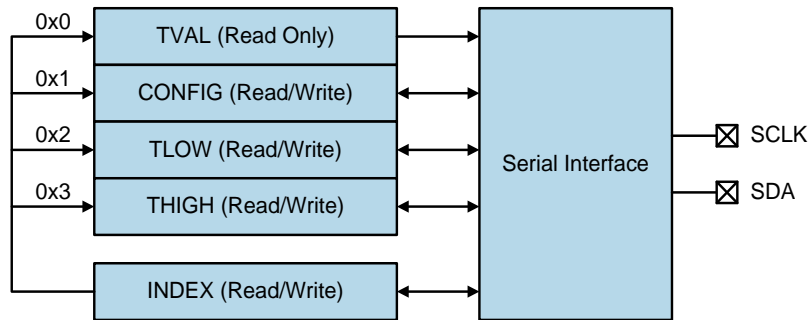

Figure 3: I²C connection

4 Software Description

The AS6200/C has 4 data registers. With the use of the index register, it is possible to address the specific data register. When powered up the address register is set to 0x0.



For additional configuration settings the Config register (0x1) has to be addressed. Please refer the data sheet for details.

Address	Symbol	Register	Description
0x0	TVAL	Temperature Register	Contains the temperature value
0x1	CONFIG	Configuration Register	Configuration settings of the temperature sensor
0x2	TLOW	T _{LOW} Register	Low temperature threshold value
0x3	THIGH	T _{HIGH} Register	High temperature threshold value

Table 4: Configuration Register

4.1 Index Register

The index register contains 8 bit, but only D0 and D1 are used.

Bit	D7	D6	D5	D4	D3	D2	D1	D0
Value	0	0	0	0	0	0	Address Bits	

Table 5: Index Register

4.2 Temperature Register

D15	D14	D13	D12	D11	D10	D9	D8	D7	D6	D5	D4	D3	D2	D1	D0
T11	T10	T9	T8	T7	T6	T5	T4	T3	T2	T1	T0	0	0	0	0
MSB Byte								LSB Byte							

Table 6: Temperature Register

The temperature register contains the digitally converted temperature value. It consists of 2 byte and can be converted according to the following formula:

Positive values= $|\text{Value}| / \text{LSB}$

Negative values= $\text{Complement}(|\text{Value}| / \text{LSB}) + 1$

Example +75°C

$$75^{\circ}\text{C} / 0.0625^{\circ}\text{C} = 1200 = \text{Binary } 0100\ 1011\ 0000 = \text{Hex } 4B0$$

Example -40°C

$$\overline{|-40^{\circ}\text{C}|} / 0.0625^{\circ}\text{C} + 1 = \overline{640} + 1 = \text{Binary } \overline{0010\ 1000\ 0000} + 1 = 1101\ 0111\ 1111 + 1 = 1101\ 10000\ 0000 = \text{Hex } D80$$

5 Schematics, Layers and BOM

The schematics, layout and BOM of the adapter board are shown below for reference.

5.1 Schematics

The schematics of the board is shown below in *Figure 4: Schematics*.

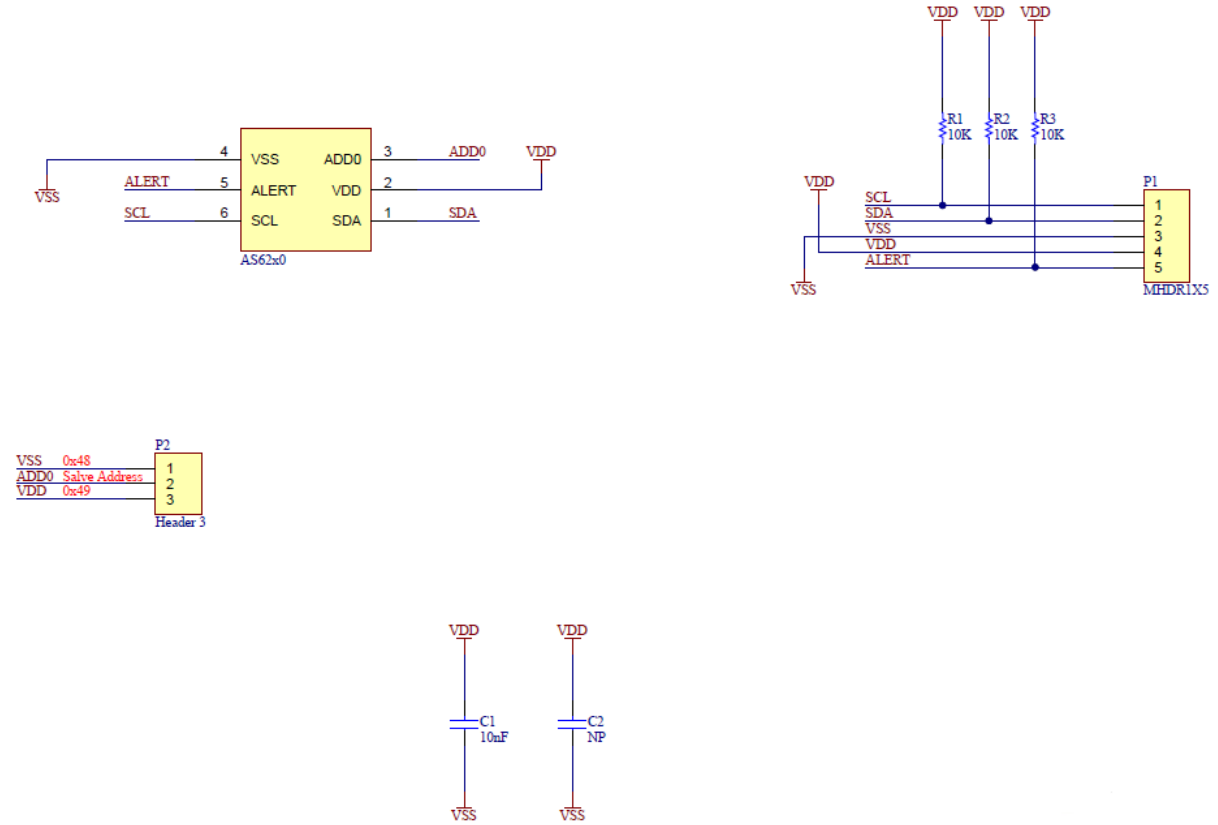

Figure 4: Schematics

5.2 Layout and Board Dimensions

The PCB layout is shown below in *Figure 5: Top Layer* and *Figure 6: Bottom Layer*.

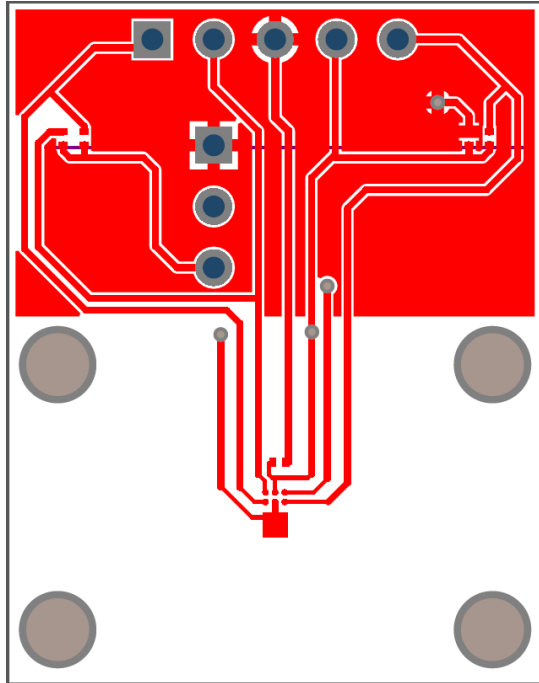

Figure 5: Top Layer

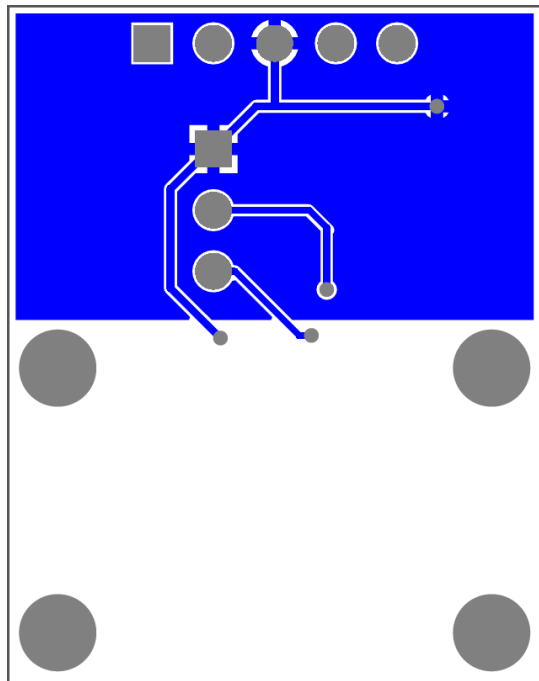

Figure 6: Bottom Layer

The board dimensions are shown below in *Figure 7: Dimensions*.

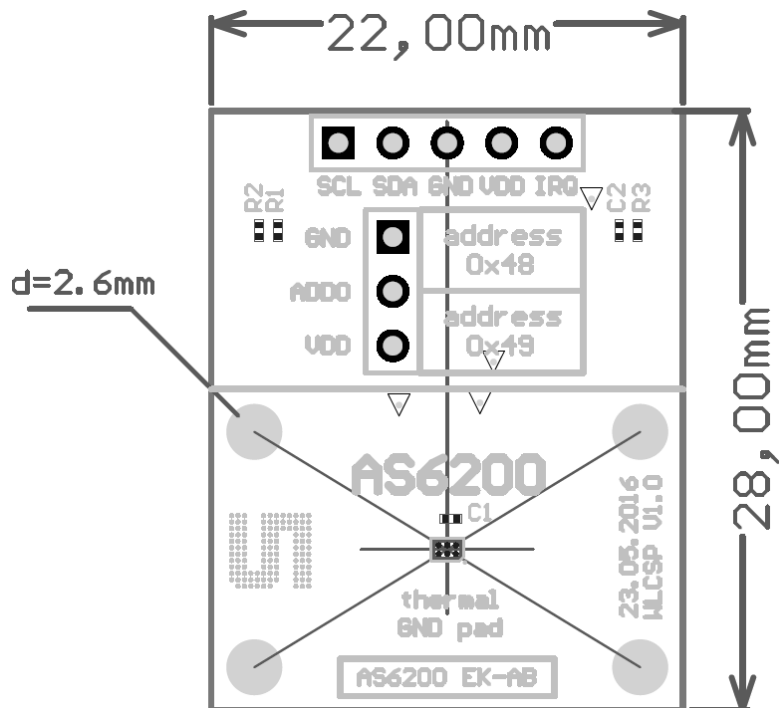

Figure 7: Dimensions

5.3 Bill of Materials

The BOM of the board is shown below in *Table 7: BOM*.

Position	Name	Value
1	R7	NP
2	R6	NP
3	R5	NP
4	R4	NP
5	R3	10K
6	R2	10K
7	R1	10K
8	P1	Header 5
9	C2	NP
10	C1	10nF
11	AS6200/C	AS6200/C WLCSP

Table 7: BOM

Ordering & Contact Information

Ordering Code	Description
AS6200-WL_EK_A	AS6200 Eval Kit Adapter Board
AS6200C-WL_EK_A	AS6200C Eval Kit Adapter Board

Buy our products or get free samples online at:

www.ams.com/ICdirect

Technical Support is available at:

www.ams.com/Technical-Support

Provide feedback about this document at:

www.ams.com/Document-Feedback

For further information and requests, e-mail us at:

ams_sales@ams.com

For sales offices, distributors and representatives, please visit:

www.ams.com/contact

Headquarters

ams AG

Tobelbaderstrasse 30

8141 Premstaetten

Austria, Europe

Tel: +43 (0) 3136 500 0

Website: www.ams.com

6 Copyrights & Disclaimer

Copyright ams AG, Tobelbader Strasse 30, 8141 Premstaetten, Austria-Europe. Trademarks Registered. All rights reserved. The material herein may not be reproduced, adapted, merged, translated, stored, or used without the prior written consent of the copyright owner.

Demo Kits, Evaluation Kits and Reference Designs are provided to recipient on an “as is” basis for demonstration and evaluation purposes only and are not considered to be finished end-products intended and fit for general consumer use, commercial applications and applications with special requirements such as but not limited to medical equipment or automotive applications. Demo Kits, Evaluation Kits and Reference Designs have not been tested for compliance with electromagnetic compatibility (EMC) standards and directives, unless otherwise specified. Demo Kits, Evaluation Kits and Reference Designs shall be used by qualified personnel only.

ams AG reserves the right to change functionality and price of Demo Kits, Evaluation Kits and Reference Designs at any time and without notice.

Any express or implied warranties, including, but not limited to the implied warranties of merchantability and fitness for a particular purpose are disclaimed. Any claims and demands and any direct, indirect, incidental, special, exemplary or consequential damages arising from the inadequacy of the provided Demo Kits, Evaluation Kits and Reference Designs or incurred losses of any kind (e.g. loss of use, data or profits or business interruption however caused) as a consequence of their use are excluded.

ams AG shall not be liable to recipient or any third party for any damages, including but not limited to personal injury, property damage, loss of profits, loss of use, interruption of business or indirect, special, incidental or consequential damages, of any kind, in connection with or arising out of the furnishing, performance or use of the technical data herein. No obligation or liability to recipient or any third party shall arise or flow out of ams AG rendering of technical or other services.

7 Revision Information

Changes from previous version to current revision 1-01 (2017-Dec-01)	Page
Initial version 1-00	
Added AS6200C 1-01	

Note: Page numbers for the previous version may differ from page numbers in the current revision.
Correction of typographical errors is not explicitly mentioned.