

Features

- No external components except PIN diode
- Supply-voltage range: 4.5V to 5.5V
- High sensitivity due to automatic sensitivity adaption (AGC) and automatic strong signal adaption (ATC)
- High immunity against disturbances from daylight and lamps
- Small size and innovative pad layout
- Available for carrier frequencies between 33kHz to 40kHz; adjusted by zener diode fusing
- TTL and CMOS compatible
- Suitable minimum burst length ≥ 10 pulses/burst

Applications

- Home entertainment applications
- Home appliances
- Remote control equipment

1. Description

The Atmel® IC ATA2525 is a complete IR receiver for data communication that was developed and optimized for use in carrier-frequency-modulated transmission applications. The IC combines small size with high sensitivity as well as high suppression of noise from daylight and lamps. An innovative and patented pad layout offers unique flexibility for assembly of IR receiver modules. The Atmel ATA2525 is available with standard carrier frequencies (33, 36, 37, 38, 40kHz) and 3 different noise suppression regulation types (standard, lamp, noise) covering requirements of different high-volume remote control solutions (please refer to selection guide available for Atmel ATA2525/ATA2526). The Atmel ATA2525 operates in a supply voltage range of 4.5V to 5.5V.

The function of Atmel ATA2525 can be described using the block diagram (see [Figure 1-1 on page 2](#)). The input stage meets two main functions. First, it provides a suitable bias voltage for the PIN diode. Secondly, the pulsed photo-current signals are transformed into a voltage by a special circuit which is optimized for low-noise applications. After amplification by a controlled gain amplifier (CGA), the signals have to pass a tuned integrated narrow bandpass filter with a center frequency f_0 which is equivalent to the chosen carrier frequency of the input signal. The demodulator is used to convert the input burst signal into a digital envelope output pulse and to evaluate the signal information quality, i.e., unwanted pulses will be suppressed at the output pin. All this is done by means of an integrated dynamic feedback circuit which varies the gain as a function of the present environmental condition (ambient light, modulated lamps etc.). Other special features are used to adapt to the current application to secure best transmission quality.

Figure 1-1. Block Diagram

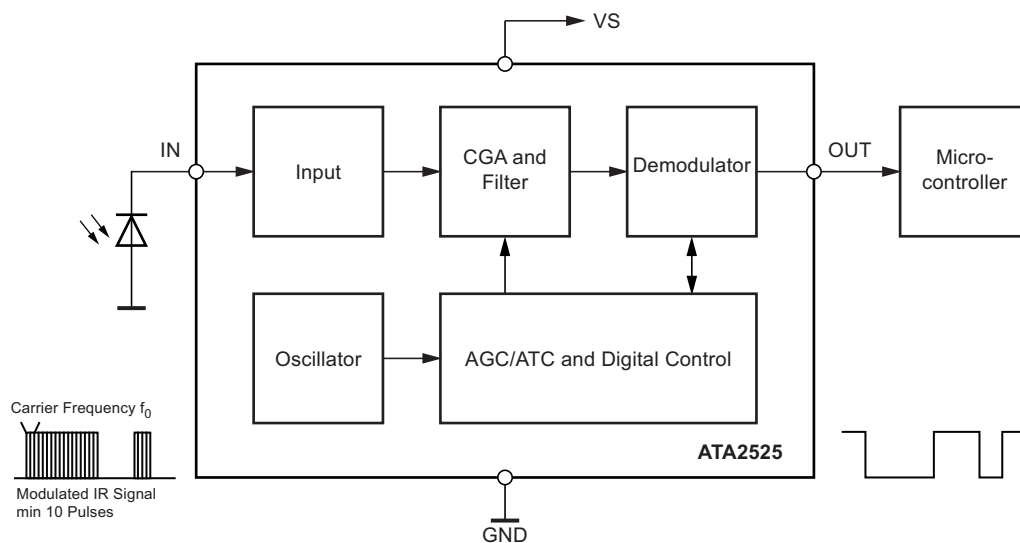

2. Absolute Maximum Ratings

Stresses beyond those listed under “Absolute Maximum Ratings” may cause permanent damage to the device. This is a stress rating only and functional operation of the device at these or any other conditions beyond those indicated in the operational sections of this specification is not implied. Exposure to absolute maximum rating conditions for extended periods may affect device reliability.

Parameters	Symbol	Value	Unit
Supply voltage	V_S	-0.3 to +6	V
Supply current	I_S	3	mA
Input voltage	V_{IN}	-0.3 to V_S	V
Input DC current at $V_S = 5V$	I_{IN}	0.75	mA
Output voltage	V_O	-0.3 to V_S	V
Output current	I_O	10	mA
Operating temperature	T_{amb}	-25 to +85	°C
Storage temperature	T_{stg}	-40 to +125	°C
Power dissipation at $T_{amb} = 25^\circ C$	P_{tot}	30	mW

3. Electrical Characteristics

$T_{amb} = -25^\circ C$ to $+85^\circ C$, $V_S = 4.5V$ to $5.5V$ unless otherwise specified.

No.	Parameters	Test Conditions	Symbol	Min.	Typ.	Max.	Unit	Type*
1	Supply							
1.1	Supply-voltage range		V_S	4.5	5	5.5	V	C
1.2	Supply current	$I_{IN} = 0$	I_S	0.8	1.1	1.4	mA	B
2	Output							
2.1	Internal pull-up resistor	$T_{amb} = 25^\circ C$; see Figure 5-7 on page 8	R_{PU}		40		k Ω	A
2.2	Output voltage low	$I_L = 2mA$; see Figure 5-7 on page 8	V_{OL}			250	mV	B
2.3	Output voltage high	$T_{amb} = 25^\circ C$	V_{OH}	$V_S - 0.25$		V_S	V	A
2.4	Output current clamping	$R_2 = 0$; see Figure 5-7 on page 8	I_{OCL}		8		mA	B
3	Input							
3.1	Input DC current	$V_{IN} = 0$; see Figure 5-7 on page 8	I_{IN_DCMAX}	-85			μA	C
3.2	Input DC current; see Figure 5-1 on page 5	$V_{IN} = 0$; $V_S = 5V$, $T_{amb} = 25^\circ C$	I_{IN_DCMAX}	-530	-960		μA	B
3.3	Minimum detection threshold current; see Figure 5-2 on page 5	Test signal: see Figure 5-6 on page 7 $V_S = 5V$, $T_{amb} = 25^\circ C$, $I_{IN_DC} = 1\mu A$; square pp, burst N = 16, $f = f_0$; $t_{PER} = 10ms$, see Figure 5-6 on page 7 ; BER = 50 ⁽¹⁾	I_{Eemin}		-600		pA	B

*) Type means: A = 100% tested, B = 100% correlation tested, C = Characterized on samples, D = Design parameter

Notes: 1. BER = Bit Error Rate; e.g., BER = 5% means that with P = 20 at the input pin 19...21 pulses can appear at the pin OUT
2. After transformation of input current into voltage

3. Electrical Characteristics (Continued)

T_{amb} = -25°C to +85°C, V_S = 4.5V to 5.5V unless otherwise specified.

No.	Parameters	Test Conditions	Symbol	Min.	Typ.	Max.	Unit	Type*
3.4	Minimum detection threshold current with AC current disturbance $I_{IN_AC100} = 3 \mu A$ at 100 Hz	Test signal: see Figure 5-6 on page 7 $V_S = 5V$, $T_{amb} = 25^\circ C$, $I_{IN_DC} = 1 \mu A$, square pp, burst $N = 16$, $f = f_0$; $t_{PER} = 10ms$, see Figure 5-6 on page 7 ; $BER = 50\%^{(1)}$	I_{Eemin}		-850		pA	C
3.5	Maximum detection threshold current	Test signal: see Figure 5-6 on page 7 $V_S = 5V$, $T_{amb} = 25^\circ C$, $I_{IN_DC} = 1 \mu A$; square pp, burst $N = 16$, $f = f_0$; $t_{PER} = 10ms$, see Figure 5-6 on page 7 ; $BER = 5\%^{(1)}$	I_{Eemax}	-400			μA	D
4	Controlled Amplifier and Filter							
4.1	Maximum value of variable gain (CGA)	$V_S = 5V$, $T_{amb} = 25^\circ C$	G_{VARMAX}		51		dB	D
4.2	Minimum value of variable gain (CGA)	$V_S = 5V$, $T_{amb} = 25^\circ C$	G_{VARMIN}		-5		dB	D
4.3	Total internal amplification ⁽²⁾	$V_S = 5V$, $T_{amb} = 25^\circ C$	G_{MAX}		71		dB	D
4.4	Center frequency fusing accuracy of bandpass	$V_S = 5V$, $T_{amb} = 25^\circ C$	f_{0_FUUSE}	-3	f_0	+3	%	A
4.5	Overall accuracy center frequency of bandpass		f_0	-6.7	f_0	+4.1	%	C
4.6	BPF bandwidth	-3dB; $f_0 = 38kHz$; see Figure 5-4 on page 6	B		3.5		kHz	B

*) Type means: A =100% tested, B = 100% correlation tested, C = Characterized on samples, D = Design parameter

Notes: 1. BER = Bit Error Rate; e.g., BER = 5% means that with $P = 20$ at the input pin 19...21 pulses can appear at the pin OUT
2. After transformation of input current into voltage

4. Reliability

Electrical qualification (1000h at 150°C) in molded SO8 plastic package

5. Typical Electrical Curves at $T_{amb} = 25^{\circ}\text{C}$

Figure 5-1. V_{IN} versus I_{IN_DC} , $V_S = 5\text{V}$

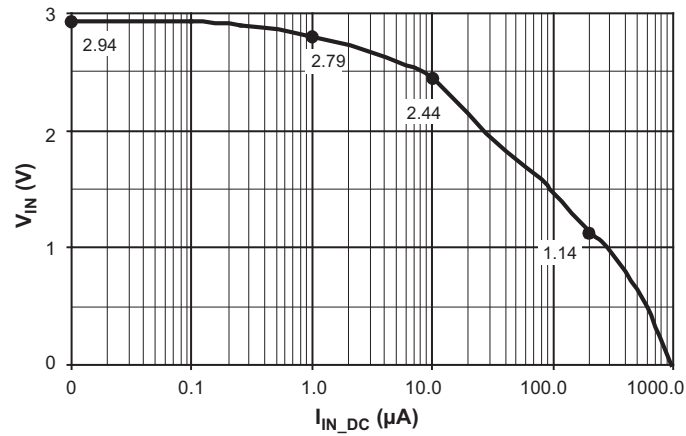

Figure 5-2. I_{Eemin} versus I_{IN_DC} , $V_S = 5\text{V}$

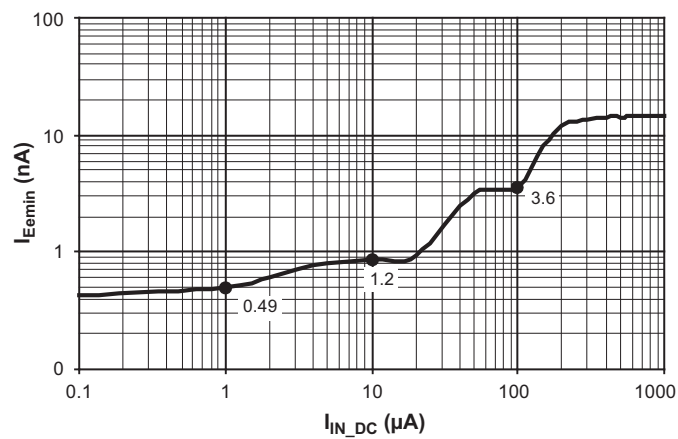

Figure 5-3. Data Transmission Rate, $V_S = 5V$

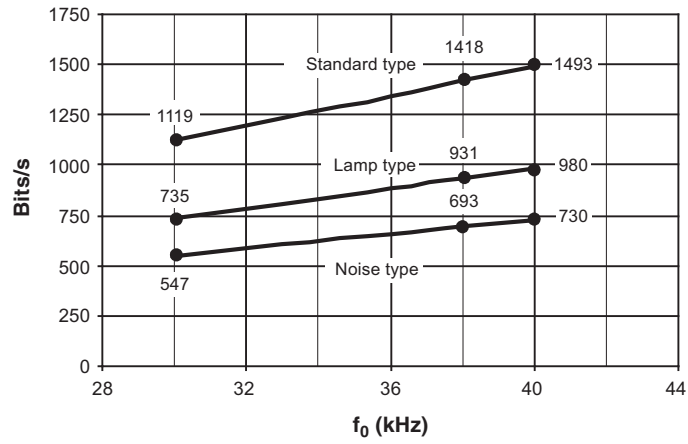
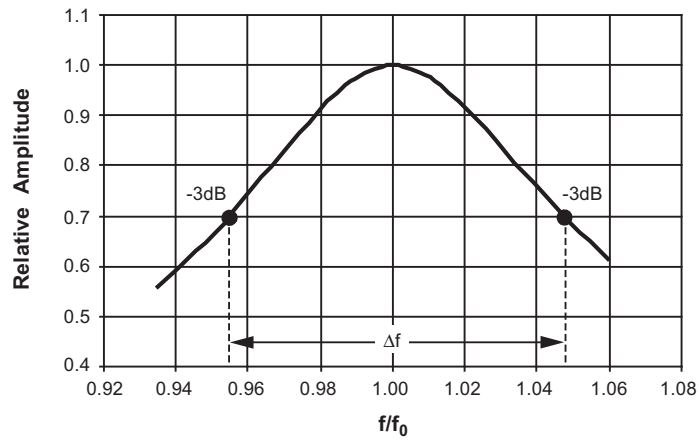
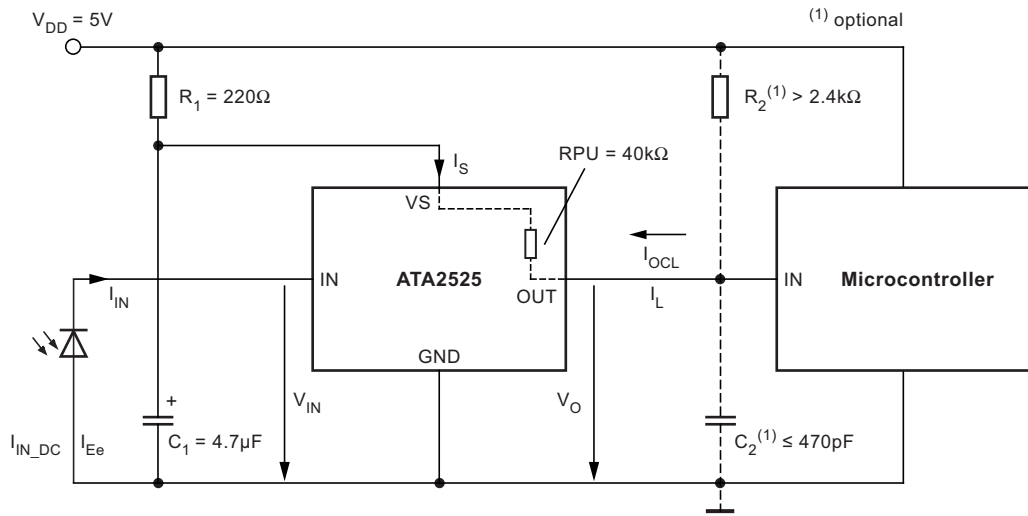

Figure 5-4. Typical Bandpass Curve



$Q = f_0/\Delta f$; $\Delta f = -3\text{dB values}$. Example: $Q = 1/(1.047 - 0.954) = 11$

Figure 5-7. Application Circuit



6. Chip Dimensions

Figure 6-1. Chip Size in μm

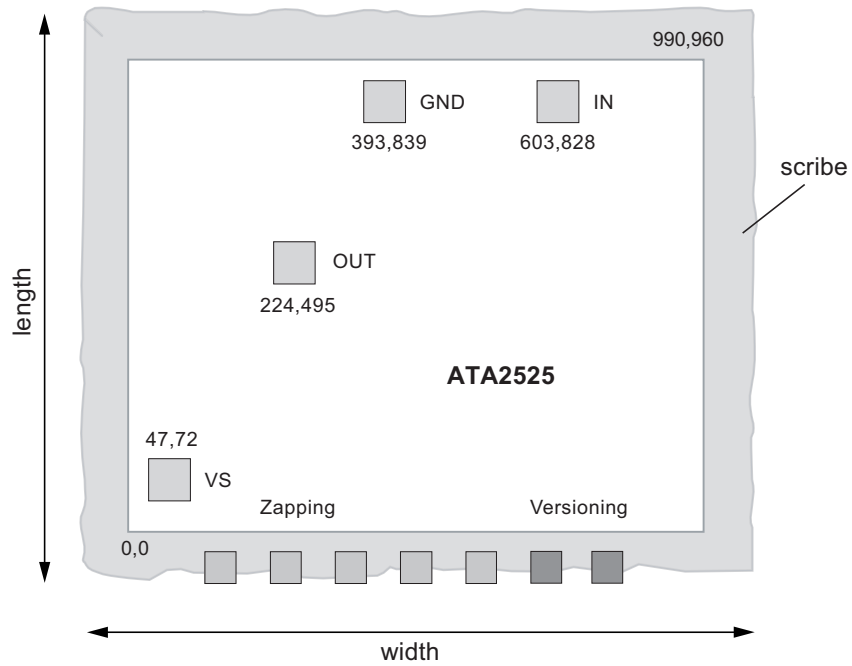

Note: Pad coordinates are for lower left corner of the pad in μm from the origin 0,0

Dimensions	Length inclusive scribe	1.04mm
	Width inclusive scribe	1.11mm
	Thickness	290 $\mu\text{m} \pm 5\%$
	Pads	80 $\mu\text{m} \times 80\mu\text{m}$
	Fusing pads	60 $\mu\text{m} \times 60\mu\text{m}$
Pad metallurgy	Material	AlCu/AlSiTi ⁽¹⁾
	Thickness	0.8 μm
Finish	Material	Si ₃ N ₄ /SiO ₂ ⁽¹⁾
	Thickness	0.7/0.3 μm

Note: 1. Value depends on manufacture location.

7. Ordering Information

Delivery: unsawn wafers (DDW) in box

Extended Type Number	D ⁽²⁾	Type
ATA2525S1xx ⁽¹⁾ C-DDW	1493	Standard type: high data rate
ATA2525S3xx ⁽¹⁾ C-DDW	980	Lamp type: enhanced suppression of disturbances, secure data transmission
ATA2525S5xx ⁽¹⁾ C-DDW	730	Noise type: best suppression of disturbances, low data rate

- Notes:
- xx means the used carrier frequency value (33, 36, 37, 38 or 40kHz)
 - Maximum data transmission rate up to bits/s with $f_0 = 40\text{kHz}$, $V_S = 5\text{V}$ (see [Figure 5-2 on page 5](#))

8. Pad Layout

Figure 8-1. Pad Layout

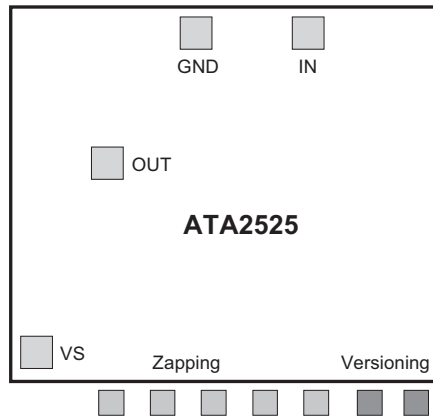

Table 8-1. Pin Description

Symbol	Function
OUT	Data output
VS	Supply voltage
GND	GND
IN	Input pin diode
Zapping	f_0 adjust
Versioning	Type adjust

9. Revision History

Please note that the following page numbers referred to in this section refer to the specific revision mentioned, not to this document.

Revision No.	History
4854H-AUTO-03/14	<ul style="list-style-type: none">• Put datasheet in the newest template
4854G-AUTO-05/10	<ul style="list-style-type: none">• Page 3: Thermal Resistance table deleted• Page 3 and 4: Pin column in Electrical Characteristics table deleted
4854F-AUTO-09/09	<ul style="list-style-type: none">• Put datasheet in newest template• Ordering Information table changed
4854E-AUTO-10/06	<ul style="list-style-type: none">• Features on page 1 changed• Applications on page 1 changed• Section 1 “Description” on page 1 changed• Section 2 “Pin Configuration” on page 2 deleted• Section 4 “Electrical Characteristics” number 3.3 on page 4 changed• Section 4 “Electrical Characteristics” number 3.4 on page 4 changed• Section 6 “ESD” on page 5 deleted• Section 10 “Ordering Information” on page 10 changed
4854D-AUTO-04/06	<ul style="list-style-type: none">• Put datasheet in a new template• Section 10 “Ordering Information” on page 10 changed



Atmel Corporation 1600 Technology Drive, San Jose, CA 95110 USA T: (+1)(408) 441.0311 F: (+1)(408) 436.4200 | www.atmel.com

© 2014 Atmel Corporation. / Rev.: 4854H-AUTO-03/14

Atmel®, Atmel logo and combinations thereof, Enabling Unlimited Possibilities®, and others are registered trademarks or trademarks of Atmel Corporation or its subsidiaries. Other terms and product names may be trademarks of others.

DISCLAIMER: The information in this document is provided in connection with Atmel products. No license, express or implied, by estoppel or otherwise, to any intellectual property right is granted by this document or in connection with the sale of Atmel products. EXCEPT AS SET FORTH IN THE ATMEL TERMS AND CONDITIONS OF SALES LOCATED ON THE ATMEL WEBSITE, ATMEL ASSUMES NO LIABILITY WHATSOEVER AND DISCLAIMS ANY EXPRESS, IMPLIED OR STATUTORY WARRANTY RELATING TO ITS PRODUCTS INCLUDING, BUT NOT LIMITED TO, THE IMPLIED WARRANTY OF MERCHANTABILITY, FITNESS FOR A PARTICULAR PURPOSE, OR NON-INFRINGEMENT. IN NO EVENT SHALL ATMEL BE LIABLE FOR ANY DIRECT, INDIRECT, CONSEQUENTIAL, PUNITIVE, SPECIAL OR INCIDENTAL DAMAGES (INCLUDING, WITHOUT LIMITATION, DAMAGES FOR LOSS AND PROFITS, BUSINESS INTERRUPTION, OR LOSS OF INFORMATION) ARISING OUT OF THE USE OR INABILITY TO USE THIS DOCUMENT, EVEN IF ATMEL HAS BEEN ADVISED OF THE POSSIBILITY OF SUCH DAMAGES. Atmel makes no representations or warranties with respect to the accuracy or completeness of the contents of this document and reserves the right to make changes to specifications and products descriptions at any time without notice. Atmel does not make any commitment to update the information contained herein. Unless specifically provided otherwise, Atmel products are not suitable for, and shall not be used in, automotive applications. Atmel products are not intended, authorized, or warranted for use as components in applications intended to support or sustain life.

SAFETY-CRITICAL, MILITARY, AND AUTOMOTIVE APPLICATIONS DISCLAIMER: Atmel products are not designed for and will not be used in connection with any applications where the failure of such products would reasonably be expected to result in significant personal injury or death ("Safety-Critical Applications") without an Atmel officer's specific written consent. Safety-Critical Applications include, without limitation, life support devices and systems, equipment or systems for the operation of nuclear facilities and weapons systems. Atmel products are not designed nor intended for use in military or aerospace applications or environments unless specifically designated by Atmel as military-grade. Atmel products are not designed nor intended for use in automotive applications unless specifically designated by Atmel as automotive-grade.