

AU9254 A21 USB Hub Controller Technical Reference Manual

Revision 1.1



© 1997-2003 Alcor Micro Corp.
All Rights Reserved

Copyright Notice

Copyright 1997 - 2003
Alcor Micro Corp.
All Rights Reserved.

Trademark Acknowledgements

The company and product names mentioned in this document may be the trademarks or registered trademarks of their manufacturers.

Disclaimer

Alcor Micro Corp. reserves the right to change this product without notice.
Alcor Micro Corp. makes no warranty for the use of its products and bears no responsibility for any errors that appear in this document. Specifications are subject to change without notice.

Contact Information:

Web site: <http://www.alcormicro.com/>

Taiwan

Alcor Micro Corp.
4F-1, No 200, Kang Chien Rd., Nei Hu,
Taipei, Taiwan, R.O.C.
Phone: 886-2-8751-1984
Fax: 886-2-2659-7723

San Clara Office

2901 Tasman Drive, Suite 206
Santa Clara, CA 95054
Phone: (408) 845-9300
Fax: (408) 845-9086

Los Angeles Office

9400 Seventh St., Bldg. A2
Rancho Cucamonga, CA 91730
Phone: (909) 989-3060
Fax: (909) 944-0464

Table of Contents

- 1.0 Introduction..... 1**
 - 1.1. Description..... 1
 - 1.2. Features 1
- 2.0 Application Block Diagram 3**
- 3.0 Pin Assignment..... 5**
- 4.0 System Architecture and Reference Design..... 10**
 - 4.1. AU9254 Block Diagram..... 10
 - 4.2. Sample Schematics11 11
- 5.0 Electrical Characteristics 15**
 - 5.1. Absolute Maximum Ratings..... 15
 - 5.2. Recommended Operating Conditions 15
 - 5.3. General DC Characteristics..... 15
 - 5.4. DC Electrical Characteristics for 5 volts operation..... 16
 - 5.5. DC Electrical Characteristics for 3.3 volts operation..... 16
 - 5.6. Crystal Oscillator Circuit Setup for Characterization..... 17
 - 5.7. USB Transceiver Characteristics 17
 - 5.8. ESD Test Results 22
 - 5.9. Latch-Up Test Results 23
- 6.0 Mechanical Information 25**
 - 6.1 Normal Size Package (Body Size 209 mil).....25
 - 6.2 Small Size Package (Body Size 150 mil).....27

1.0 Introduction

1.1. Description

The AU9254A21 is an integrated single chip USB hub controller designed for the emerging industry-standard Universal Serial Bus (USB). The AU9254A21 supports four USB downstream ports. Each downstream port has power switch control, and over-current sensing.

Single chip integration makes the AU9254A21 the most cost effective stand-alone USB hub solution available in the market. Downstream ports can be used to connect various USB peripheral devices, such as USB printers, modems, scanners, cameras, mice, or joysticks to the system without adding external glue logic.

1.2. Features

- Fully compliant with the Universal Serial Bus Specification, version 1.1.
- USB hub design is compliant with Universal Serial Bus Hub Specification, revision 1.1.
- Single chip integrated USB hub controller with embedded proprietary processor.
- Supports four bus-powered/self-powered downstream ports.
- Built-in 3.3v voltage regulator allows single +5V operating voltage, resulting in reduced overall system cost.
- Runs at 12Mhz frequency.
- 28-pin SSOP package, both normal size (body size 209 mil) and smaller size (body size 150 mil) are available.

This Page Intentionally Left Blank

2.0 Application Block Diagram

The AU9254A21 is a single chip 4-port USB hub controller. The upstream port is connected to the USB system. The downstream ports can be used for a mouse, joystick, scanner, printer or other device.

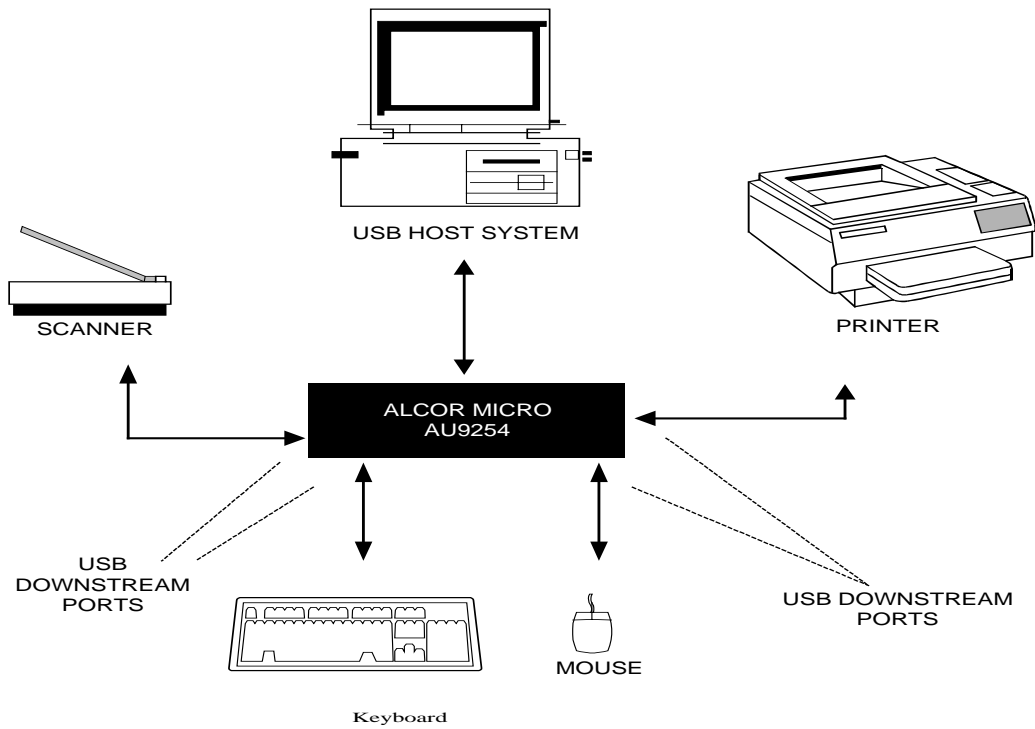

This Page Intentionally Left Blank

3.0 Pin Assignment

The AU9254A21 is packaged as a 28-pin shrink small outline plastic package (SSOP). The figure on the following page shows the signal names for each of the pins on the chip. Accompanying the figure is the table that describes each of the pin signals.

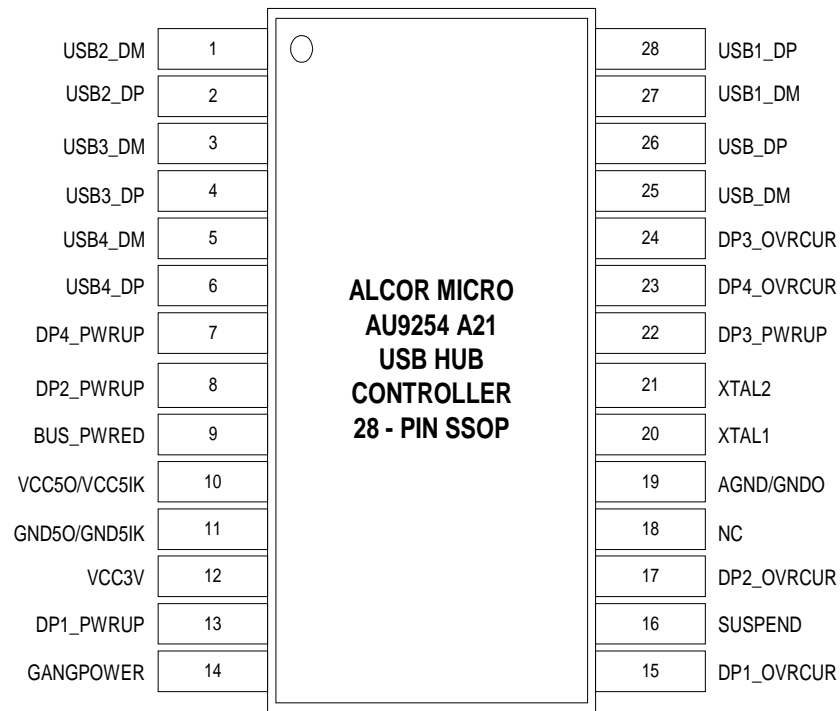

Table 3-1. Pin Descriptions of Au9254A21, 28-pin SSOP

Pin No	Pin Name	Input/Output	Description
1	USB_DM	Input/Output	USB D- for downstream port 2; add 15K Ω pull-down to ground.
2	USB2_DP	Input/Output	USB D+ for downstream port 2; add 15K Ω pull-down to ground.
3	USB3_DM	Input/Output	USB D- for downstream port 3; add 15K Ω pull-down to ground.
4	USB3_DP	Input/Output	USB D+ for downstream port 3; add 15K Ω pull-down to ground.
5	USB4_DM	Input/Output	USB D- for downstream port 4; add 15K Ω pull-down to ground.
6	USB4_DP	Input/Output	USB D+ for downstream port 4; add 15K Ω pull-down to ground.
7	DP4_PWRUP	Output	Downstream port 4 power switch control. Active low.
8	DP2_PWRUP	Output	Downstream port 2 power switch control. Active low.
9	BUS_PWRED	Input	Bus power. Low indicates bus-powered.
10	VCC50/VCC5IK	Power	+5 V power supply.
11	GND50/GND5IK	Power	Ground.
12	VCC3V	Power	3.3V output for upstream D+ pull-up.
13	DP1_PWRUP	Output	Downstream port 1 power switch control. Active low.
14	GANGPOWER	Input	Ganged or individual port power selection. Add a 10k pull down for ganged power. 10k pull up for individual power.
15	DP1_OVRCUR	Input	Downstream port 1 over-current indicator. Active low.

16	SUSPEND	Output	Device is in suspended state: Active high.
17	DP2_OVRCUR	Input	Downstream port 2 over-current indicator. Active low.
18	NC		
19	AGND/GNDO	Power	+5 V power supply.
20	XTAL_1	Input	Crystal in.
21	XTAL_2	Output	Crystal out.
22	DP3_PWRUP	Output	Downstream port 3 power switch control. Active low.
23	DP4_OVRCUR	Input	Downstream port 4 over-current indicator. Active low.
24	DP3_OVRCUR	Input	Downstream port 3 over-current indicator. Active low.
25	USB_DM	Input/Output	USB D- for upstream.
26	USB_DP	Input/Output	USB D+ for upstream port. Need external 1.5K Ω pull-up to 3.3V.
27	USB1_DM	Input/Output	USB D- for downstream port 1; add 15K Ω pull-down to ground.
28	USB1_DP	Input/Output	USB D+ for downstream port 1; add 15K Ω pull-down to ground.

This Page Intentionally Left Blank

4.0 System Architecture and Reference Design

4.1. AU9254A21 Block Diagram

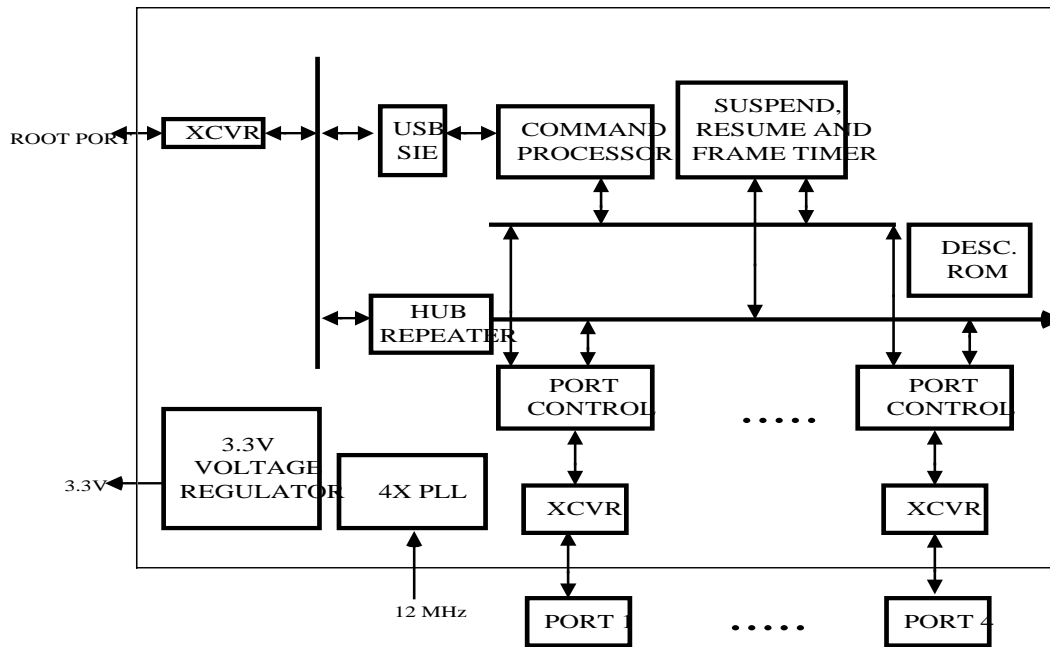

4.2 Sample Schematics

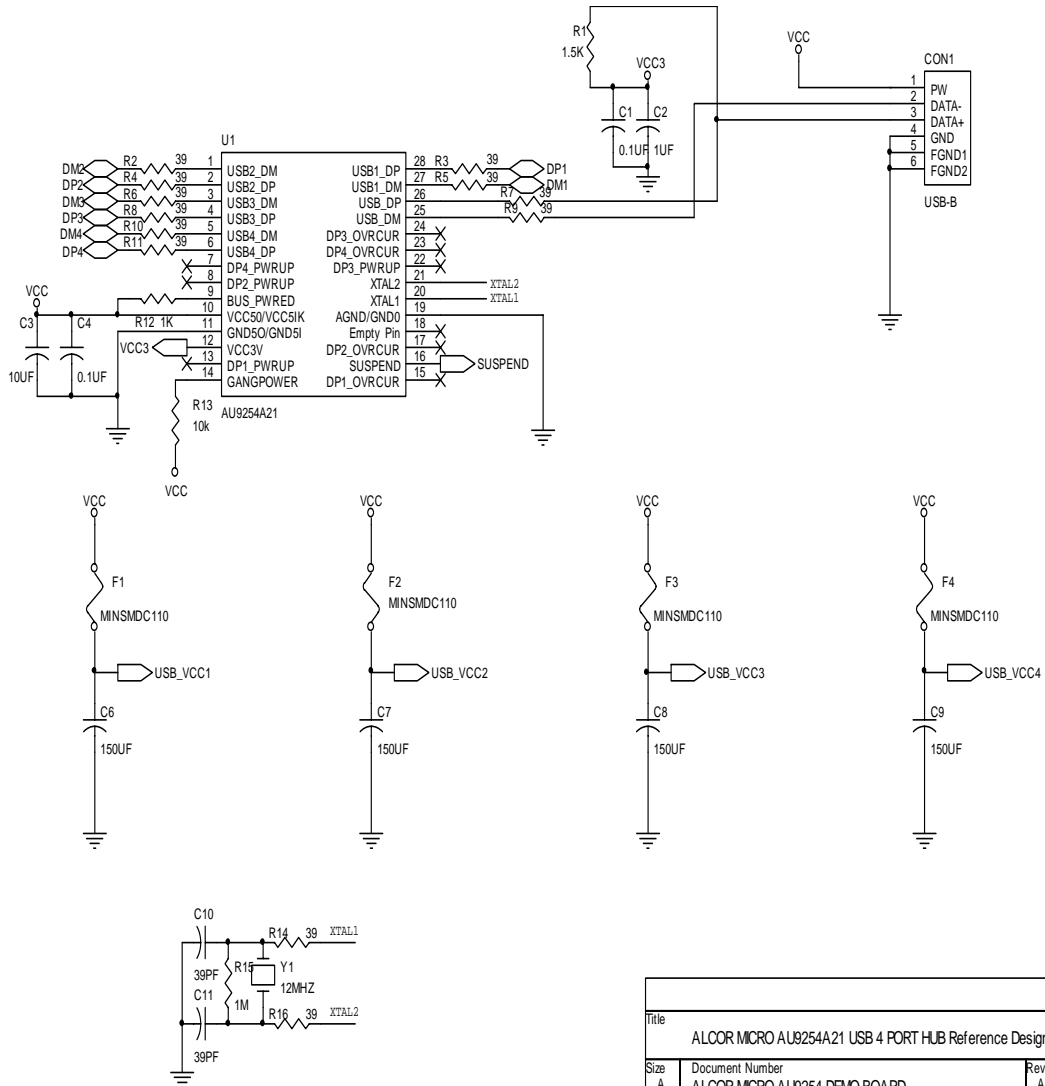

Disclaimer: This schematic is for reference only. Alcor Micro Corp. bears no responsibility for any error that appear in this document. Specifications are subject to change without notice.

Title		
ALCOR MICRO AU9254A21 USB 4 PORT HUB Reference Design		
Size	Document Number	Rev
A	ALCOR MICRO AU9254 DEMO BOARD	A
Date:	Wednesday, December 20, 2000	Sheet 1 of 2

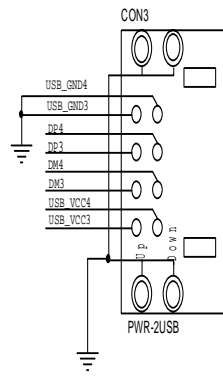
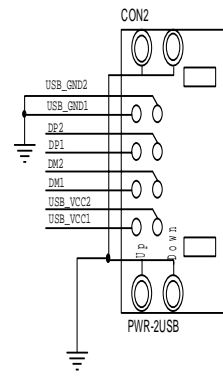
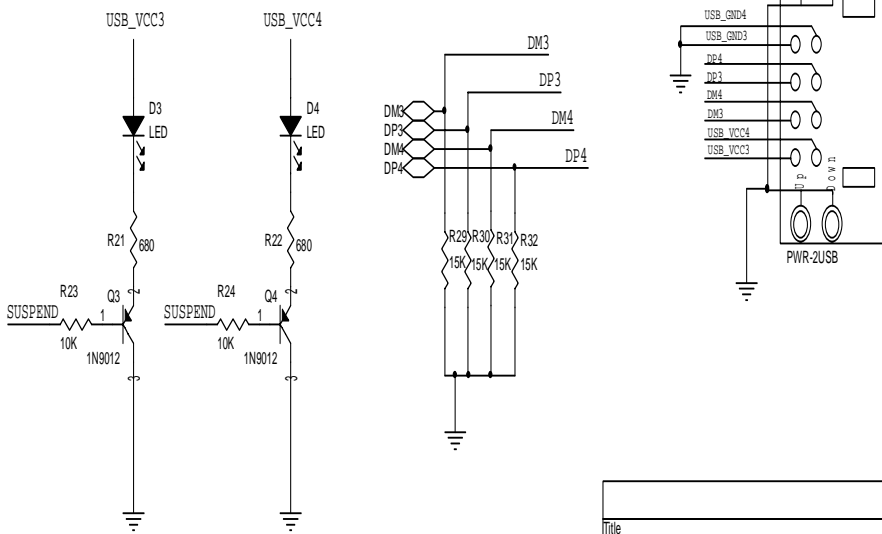
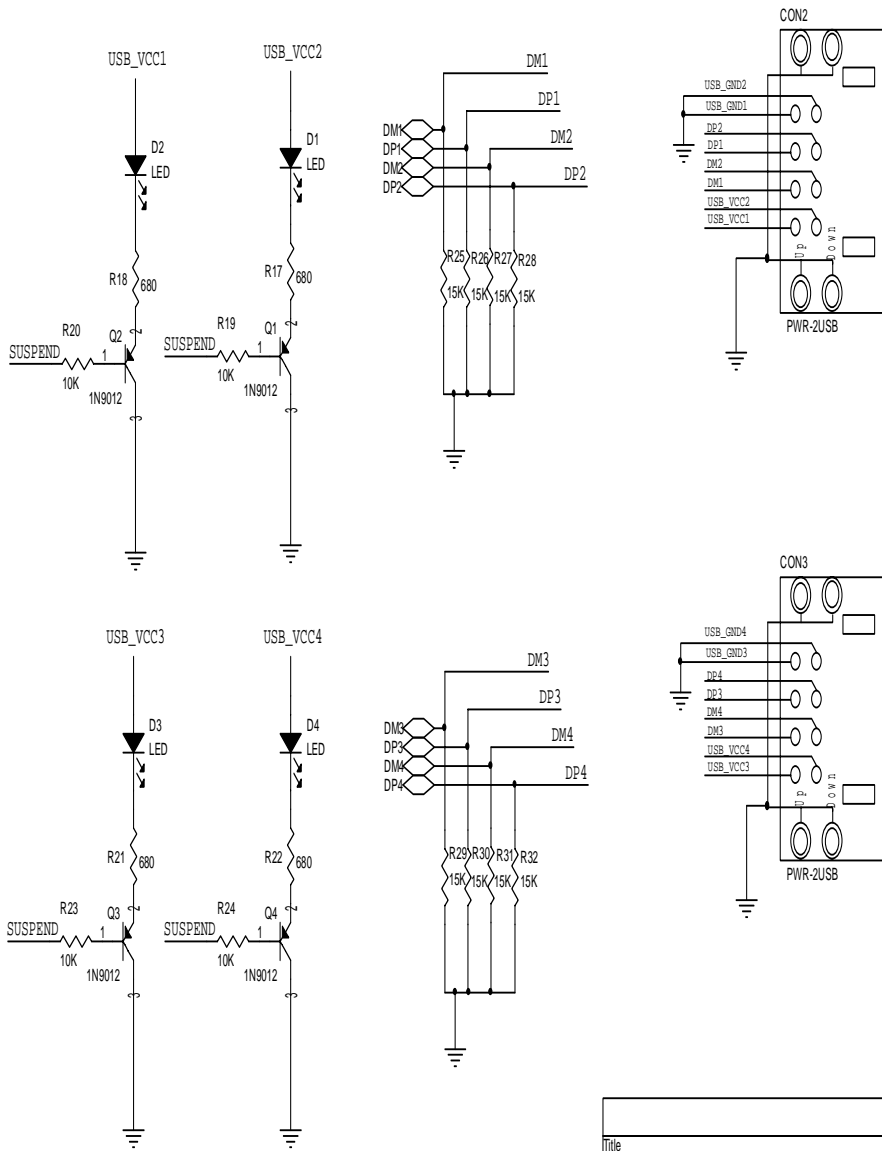

Title		
ALCOR MICRO AU9254A21 USB 4 PORT HUB Reference Design		
Size	Document Number	Rev
A	ALCOR MICRO AU9254 DEMO BOARD	A
Date:	Wednesday, December 20, 2000	Sheet 2 of 2

Disclaimer: This schematic is for reference only. Alcor Micro Corp. bears no responsibility for any error that appear in this document. Specifications are subject to change without notice.

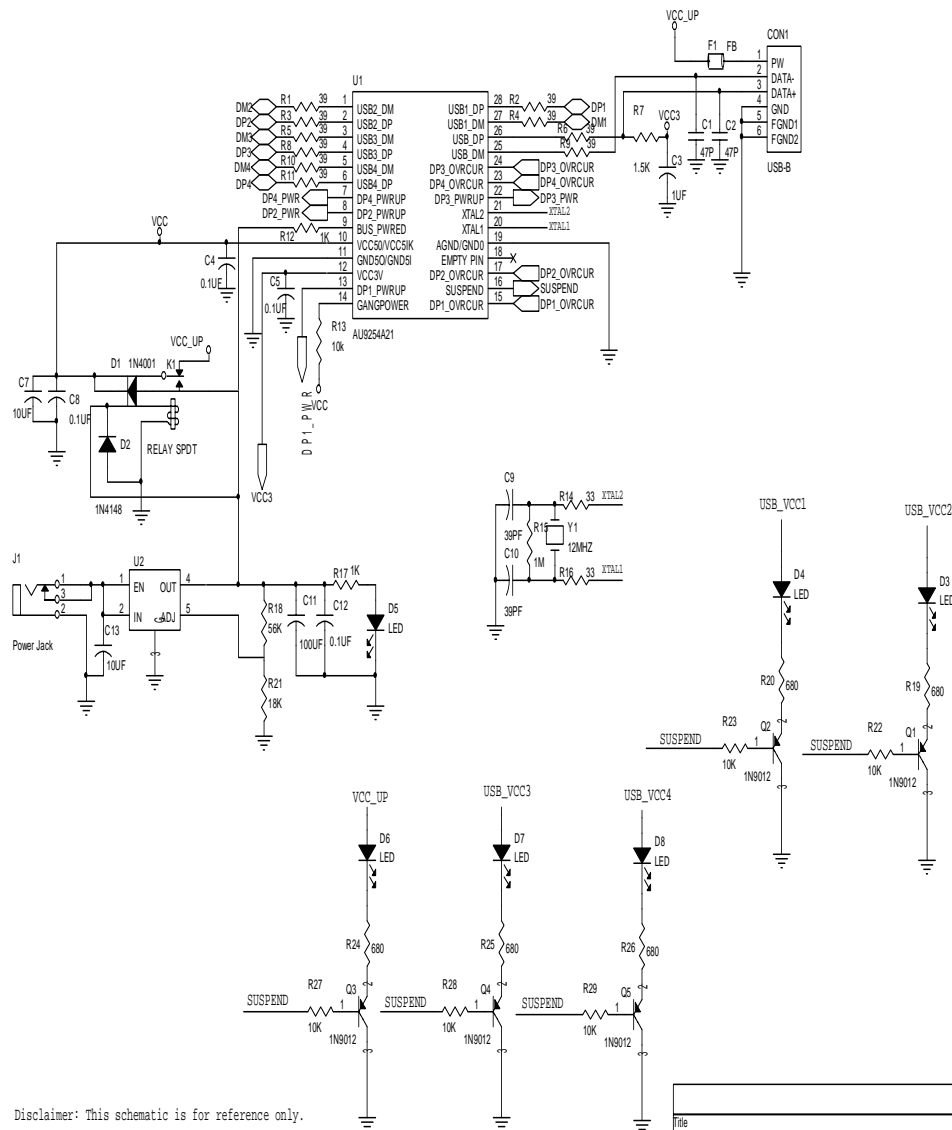

Disclaimer: This schematic is for reference only. Alcor Micro Corp. makes no warranty for the use of its products and bears no responsibility for any error that appear in this document. Specifications are subject to change without notice.

Title		
Alcor Micro Au9254A21 USB 4 Port Hub Reference Design		
Size	Document Number	Rev
A4	Au9254A21 USB Hub Buspower and Selfpower Changed	A
Date:	Thursday, September 13, 2001	Sheet 1 of 2

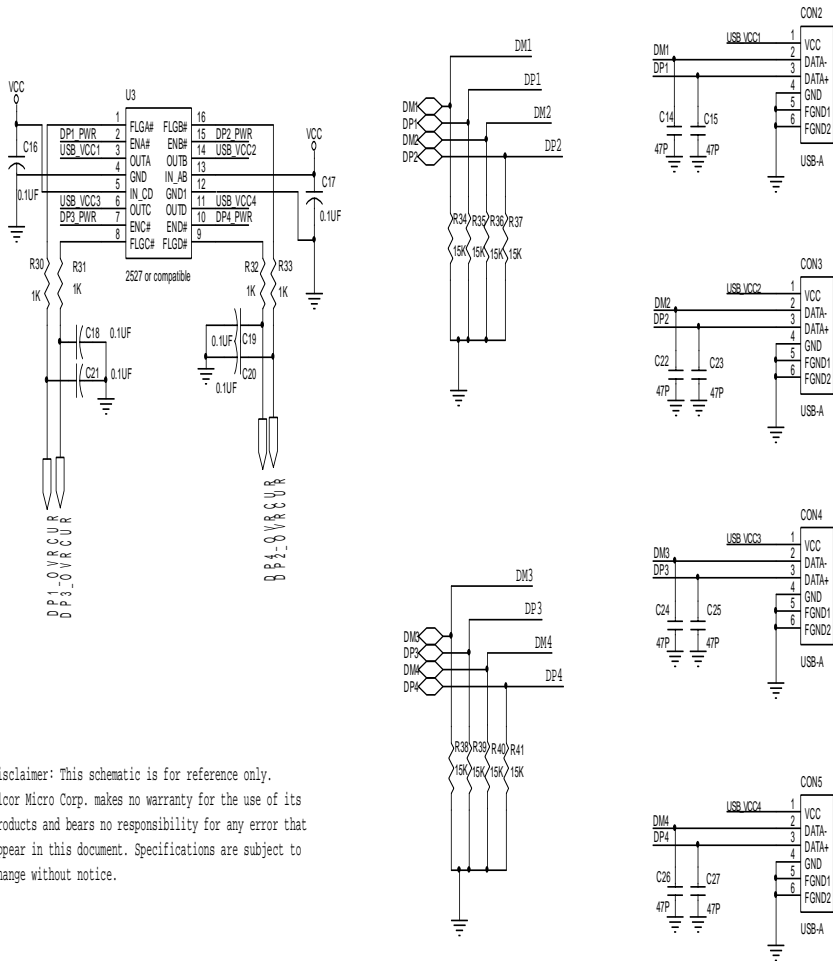

Disclaimer: This schematic is for reference only. Alcor Micro Corp. makes no warranty for the use of its products and bears no responsibility for any error that appear in this document. Specifications are subject to change without notice.

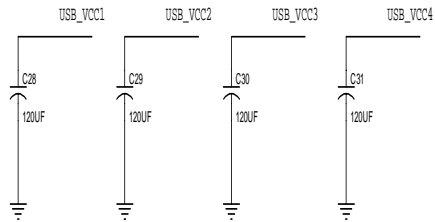

Title		
Alcor Micro Au9254A21 USB 4 Port Hub Reference Design		
Size	Document Number	Rev
A4	Au9254A21 USB Hub Buspower Selfpower Changed	A
Date:	Thursday, September 13, 2001	Sheet 2 of 2

This Page Intentionally Left Blank

5.0 Electrical Characteristics

5.1. Absolute Maximum Ratings

SYMBOL	PARAMETER	RATING	UNITS
V _{CC}	Power Supply	-0.3 to 6.0	V
V _{IN}	Input Voltage	-0.3 to V _{CC} +0.3	V
V _{OUT}	Output Voltage	-0.3 to V _{CC} +0.3	V
T _{STG}	Storage Temperature	-40 to 125	°C

5.2. Recommended Operating Conditions

SYMBOL	PARAMETER	MIN	TYP	MAX	UNITS
V _{CC}	Power Supply	4.5	5.0	5.5	V
V _{IN}	Input Voltage	0		V _{CC}	V
T _{OPR}	Operating Temperature	-5		85	°C

5.3. General DC Characteristics

SYMBOL	PARAMETER	CONDITIONS	MIN	TYP	MAX	UNITS
I _{IL}	Input low current	no pull-up or pull-down	-1		1	μA
I _{IH}	Input high current	no pull-up or pull-down	-1		1	μA
I _{OZ}	Tri-state leakage current		-10		10	μA
C _{IN}	Input capacitance			4		pF
C _{OUT}	Output capacitance			4		pF
C _{BID}	Bi-directional buffer capacitance			4		pF

5.4. DC Electrical Characteristics for 5 volts operation

(Under Recommended Operating Conditions and $V_{CC}=4.5v \sim 5.5v$, $T_j = -40^{\circ}C$ to $+85^{\circ}C$)

SYMBOL	PARAMETER	CONDITIONS	MIN	TYP	MAX	UNITS
V_{IL}	Input Low Voltage	TTL			0.8	V
V_{IL}	Input Low Voltage	CMOS			$0.3 \cdot V_{CC}$	V
V_{IL}	Schmitt input Low Voltage	TTL		1.10		V
V_{IL}	Schmitt input Low Voltage	CMOS		1.84		V
V_{IH}	Input High Voltage	TTL	2.2			V
V_{IH}	Input High Voltage	CMOS	$0.7 \cdot V_{CC}$			V
V_{IH}	Schmitt input High Voltage	TTL		1.87		V
V_{IH}	Schmitt input High Voltage	CMOS		3.22		V
V_{OL}	Output low voltage	$I_{OL}=2, 4, 8, 12, 16, 24$ mA			0.4	V
V_{OH}	Output high voltage	$I_{OH}=2, 4, 8, 12, 16, 24$ mA	3.5			V
R_I	Input Pull-up/down resistance	$V_{il}=0V$ or $V_{ih}=V_{CC}$		50		$K\Omega$

5.5. DC Electrical Characteristics for 3.3 volts operation

(Under Recommended Operating Conditions and $V_{CC}=3.0v \sim 3.6v$, $T_j = -40^{\circ}C$ to $+85^{\circ}C$)

SYMBOL	PARAMETER	CONDITIONS	MIN	TYP	MAX	UNITS
V_{IL}	Input Low Voltage	CMOS			$0.3 \cdot V_{CC}$	V
V_{IL}	Schmitt input Low Voltage	CMOS		1.22		V
V_{IH}	Input High Voltage	CMOS	$0.7 \cdot V_{CC}$			V
V_{IH}	Schmitt input High Voltage	CMOS		2.08		V
V_{OL}	Output low voltage	$I_{OL}=2, 4, 8, 12, 16, 24$ mA			0.4	V
V_{OH}	Output high voltage	$I_{OH}=2, 4, 8, 12, 16, 24$ mA	2.3			V
R_I	Input Pull-up/down resistance	$V_{il}=0V$ or $V_{ih}=V_{CC}$		75		$K\Omega$

5.6. Crystal Oscillator Circuit Setup for Characterization

The following setup was used to measure the open loop voltage gain for crystal oscillator circuits. The feedback resistor serves to bias the circuit at its quiescent operating point and the AC coupling capacitor, C_s , is much larger than C_1 and C_2 .

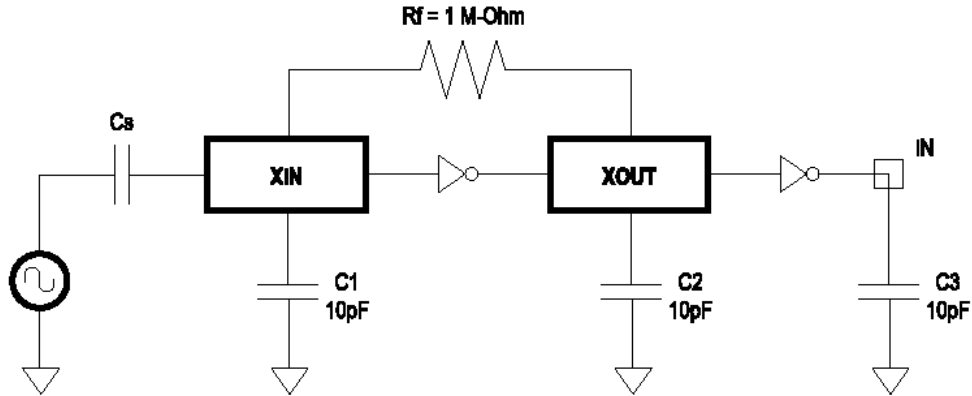

5.7. USB Transceiver Characteristics

RECOMMENDED OPERATING CONDITIONS

SYMBOL	PARAMETER	CONDITIONS	LIMITS		UNIT
			MIN	MAX	
V_{CC}	DC supply voltage		3.0	3.6	V
V_I	DC input voltage range		0	5.5	V
$V_{I/O}$	DC input range for I/Os		0	V_{CC}	V
V_O	DC output voltage range		0	V_{CC}	V
T_{AMB}	Operating ambient temperature range in free air	See DC and AC characteristics for individual device	0	70	C

ABSOLUTE MAXIMUM RATINGS (Notes 1 and 2)

In accordance with the Absolute Maximum Rating System, Voltages are referenced to GND (Ground=0v)

SYMBOL	PARAMETER	CONDITIONS	LIMITS		UNIT
			MIN	MAX	
V_{CC}	DC supply voltage		-0.5	+6.5	V
I_{IK}	DC input diode current	$V_i < 0$		-50	mA
V_i	DC input voltage	Note 3	-0.5	+5.5	V
V_{IO}	DC input voltage range for I/Os		-0.5	$V_{CC} + 0.5$	V
I_{OK}	DC output diode current	$V_o > V_{CC}$ or $V_o < 0$		+/-50	mA
V_o	DC output voltage	Note 3	-0.5	$V_{CC} + 0.5$	V
I_o	DC output source sink current for VP/VM and RCV pins	$V_o = 0$ to V_{CC}		+/-15	mA
I_o	DC output source or sink current for D+/D- pins	$V_o = 0$ to V_{CC}		+/-50	mA
I_{CC}, I_{GND}	DC V_{CC} or GND current			+/-100	mA
T_{STO}	Storage temperature range		-60	+150	C
P_{TOT}	Power dissipation per package				mW

NOTES:

1. Stresses beyond those listed may cause permanent damage to the device. These are stress ratings only and functional operation of the device at these or any other conditions beyond those indicated under "Recommended Operating Conditions" is not implied. Exposure to absolute maximum rated conditions for extended periods may affect device reliability.
2. The performance capability of a high performance integrated circuit in conjunction with its thermal environment can create junction temperatures which are detrimental to reliability. The maximum junction temperature of this integrated circuit should not exceed 150°C.
3. The input and output voltage ratings may be exceeded if the input and output clamp current ratings are observed.

DC ELECTRICAL CHARACTERISTICS

Over recommended operating conditions. Voltages are referenced to GND (Ground=0V).

SYMBOL	PARAMETER	TEST CONDITIONS	LIMITS			UNIT
			-4 °C to +85 °C			
			MIN	TYP	MAX	
VHYS	Hysteresis on inputs	V _{cc} =3.0V to 3.6V (Note 3)	0.3	0.4	0.5	V
VIH	HIGH level input	V _{cc} =3.0V to 3.6V (Note 3)		1.5	2.0	V
VIL	LOW level input	V _{cc} =3.0V to 3.6V (Note 3)	0.8	1.1		V
RoH	Output impedance (HIGH state)	Note 2	28	34	43	ohm
RoL	Output impedance (LOW state)	Note 2	28	35	43	ohm
VOH	HIGH level output (Note 3)	V _{cc} =3.0V I _o =6mA V _{cc} =3.0V I _o =4mA V _{cc} =3.0V I _o =100µA	2.2 2.4 2.8	2.7		V
VOL	LOW level output (Note 3)	V _{cc} =3.0V I _o =6mA V _{cc} =3.0V I _o =4mA V _{cc} =3.0V I _o =100µA		0.3	0.7 0.4 0.2	V
IQ	Quiescent supply current	V _{cc} =3.6V V _I =V _{cc} or GND I _o =0		330	600	µA
I _{sup}	Supply current in suspend	V _{cc} =3.6V V _I =V _{cc} or GND I _o =0			70	µA
IFS	Active supply current (Full Speed)	V _{cc} =3.3V		9	14	mA
ILS	Active supply current (Low Speed)	V _{cc} =3.3V		2		mA
I _{Leak}	Input leakage current	V _{cc} =3.6V V _I =5.5V or GND, not for I/O Pins		+/- 0.1	+/- 0.5	µA
IOFF	3-state output OFF-state current	V _i =V _{ih} or V _{il} ; V _o =V _{cc} or GND			+/-10	µA

NOTES:

1. All typical values are at V_{cc}=3.3V and T_{amb}=25°C.
2. This value includes an external resistor of 24 ohm +/-1%. See "Load D+ and D-" diagram for testing details.
3. All signals except D+ and D-.

AC ELECTRICAL CHARACTERISTICS

GND=0V, $t_r = t_f = 3.0$ ns; $C_L = 50$ pF; $R_L = 500$ Ohms

SYMBOL	PARAMETER	WAVEFORM	LIMITS $T_{(AMB)}$					UNIT
			$0^\circ\text{C to }+25^\circ\text{C}$			$0^\circ\text{C to }+70^\circ\text{C}$		
			MIN	TYP	MAX	MIN	MAX	
tpLH tpHL	VMO/VPO to D+/D- Full Speed	1	0 0		12 12	0 0	14 14	ns
trise tfall	Rise and Fall Times Full Speed	2	4 4	9 9	20 20	4 4	20 20	ns
tRFM	Rise and Fall Time Matching Full Speed		90		110	90	110	%
tpLH tpHL	VMO/VPO to D+/D- Low Speed	1		120 120	300 300		300 300	ns
trise tfall	Rise and Fall Times Low Speed	2	75 75		300 200	75 75	300 200	ns
tRFM	Rise and Fall Time Matching Low Speed		70		130	70	130	%
tpLH tpHL	D+/D- to RCV	3		9 9	16 16		16 16	ns
tpLH tpHL	D+/D- to VP/VM	1		4 4	8 8		8 8	ns
tpHZ tpZH tpLZ tpZL	OE# to D+/D- $R_L =$ 500ohm	4			12 12 10 10		12 12 10 10	ns
tsu	Setup for SPEED	5	0					ns
Vcr	Crossover point'	3	1.3		2.0	1.3	2.0	V

NOTES:

- The crossover point is in the range of 1.3V to 2.5V for the low speed mode with a 50 pF capacitance.

AC WAVEFORM 1.
D+/D- TO VP/VM OR VP/VM TO D+/D-

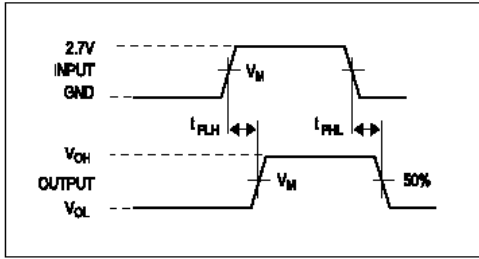

AC WAVEFORM 2.
RISE AND FALL TIMES

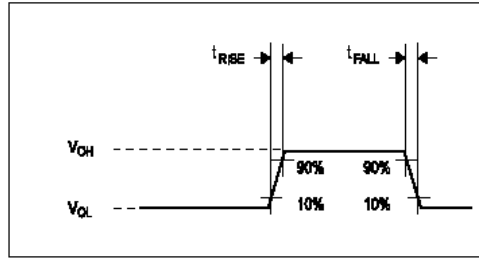

AC WAVEFORM 3.
D+/D- TO RCV

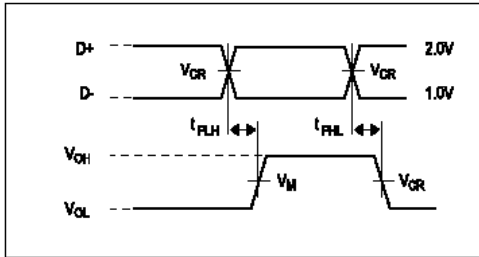

AC WAVEFORM 4.
OE# TO D+/D-

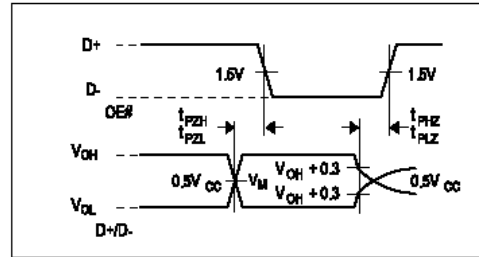

AC WAVEFORM 5.
SETUP FOR SPEED

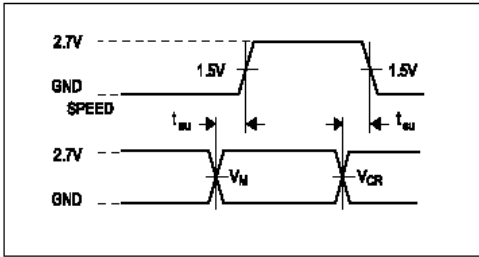

TEST CIRCUIT 1.
LOAD FOR VM/VP AND RCV

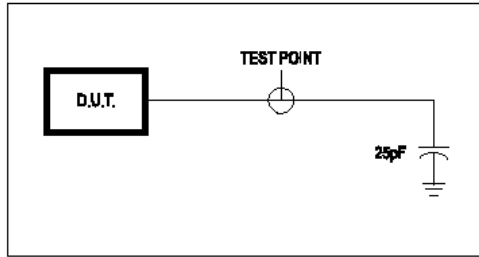

TEST CIRCUIT 2.
LOAD FOR ENABLE AND DISABLE TIMES

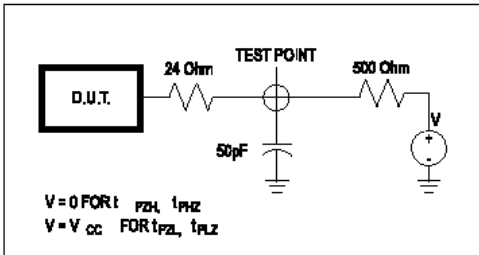

TEST CIRCUIT 3.
LOAD FOR D+/D-

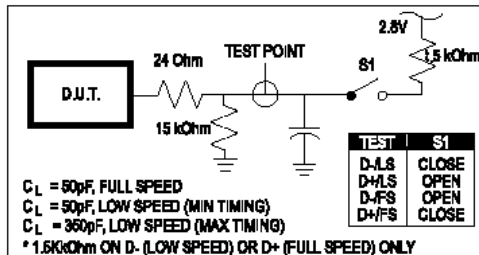

5.8.ESD Test Results

Test Description: ESD Testing was performed on a Zapmaster system using the Human-Body-Model (HBM) and Machine-Model (MM), according to MIL-STD 883 and EIAJ IC-121 respectively.

- Human-Body-Model stresses devices by sudden application of a high voltage supplied by a 100pF capacitor through 1.5k-ohm resistance.
- Machine-Model stresses devices by sudden application of a high voltage supplied by a 200pF capacitor through very low (0 ohm) resistance.

Test Circuit & Condition

- Zap Interval: 1 second
- Number of Zaps: 3 positive and 3 negative at room temperature
- Criteria: I-V Curve Tracing

ESD Data

Model	Iode	S/S	Target	Results
HBM	Vdd, Vss, I/C	15	6000V	PASS
MM	Vdd, Vss, I/C	15	200V	PASS

5.9. Latch-Up Test Results

Test Description: Latch-Up testing was performed at room ambient using an IMCS-4600 system which applies a stepped voltage to one pin per device with all other pins open except Vdd and Vss which were biased to 5Volts and ground respectively.

Testing was started at 5.0V (Positive) or 0V (Negative), and the DUT was biased for 0.5 seconds.

If neither the PUT current supply nor the device current supply reached the predefined limit (DUT=00mA, Icc=100mA), then the voltage was increased by 0.1Volts and the pin was tested again.

This procedure was recommended by the JEDEC JC-40.2 CMOS Logic standardization committee.

Notes:

1. DUT: The device under test.
2. PUT: The pin under test.

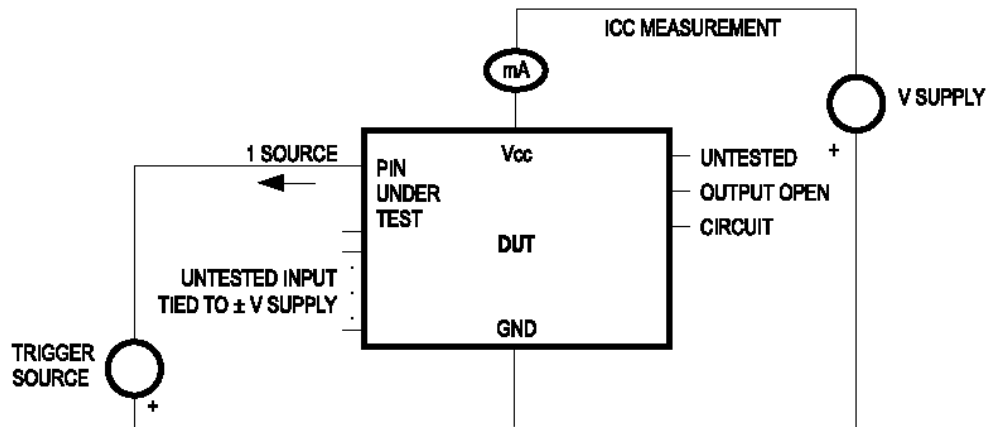

Test Circuit: Positive Input/Output Overvoltage/Overcurrent

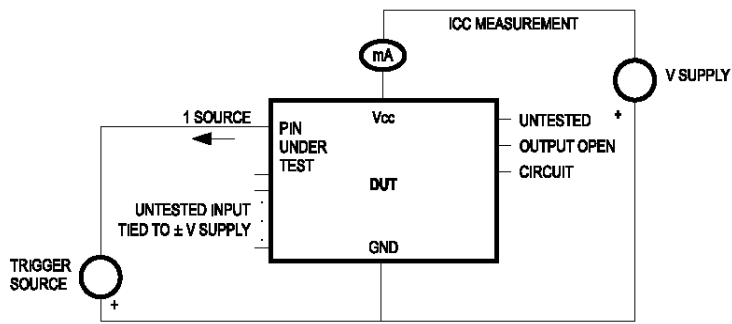

Test Circuit: Negative Input/Output Overvoltage/Overcurrent

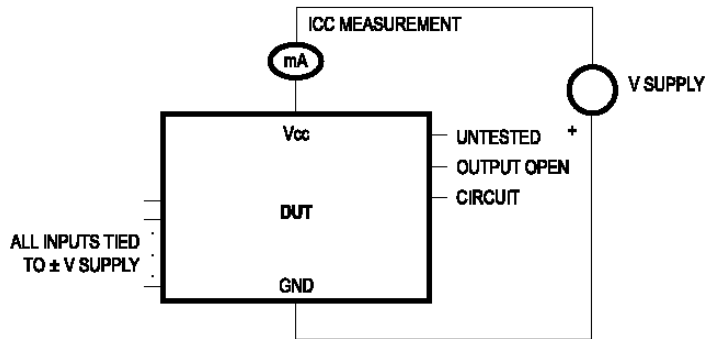

Supply Overvoltage Test

Latch-Up Data

Mode		Voltage (V)	CUITENT(ma)	S/S	Results
Voltage	+	11.0		5	Pass
	-	11.0		5	Pass
Current	+	200		5	Pass
	-	200		5	Pass
Vdd - Vxx		9.0		5	Pass

6.0 Mechanical Information

6.1. Normal Size Package (Body Size 209 mil)

Following diagrams show the dimensions of the normal size 28-pin SSOP package.

Measurements are in inches. Dimensions do not include mold flash and dambar protrusion; allowable mold flash is 0.010 inch.

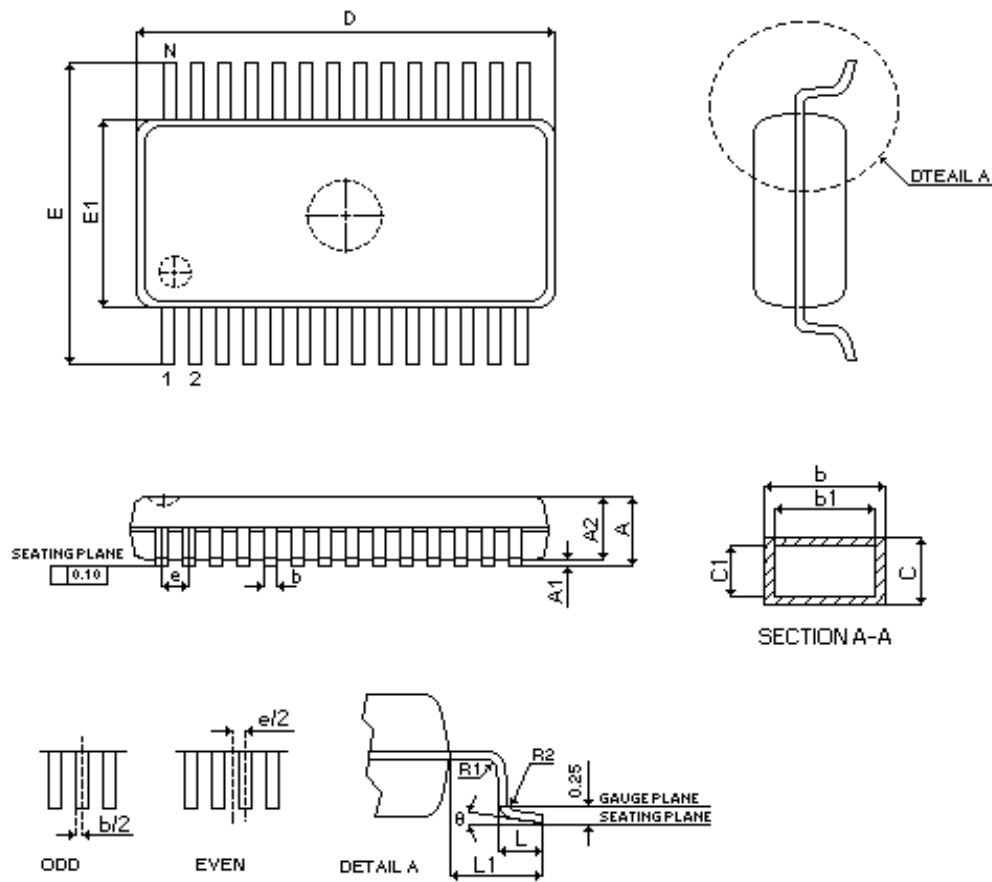

SYMBOL	COMMON DIMENSION MILLIMETERS			COMMON DIMENSION INCH		
	MIN.	NOM.	MAX.	MIN.	NOM.	MAX.
A			2.00			0.079
A1	0.05			0.002		
A2	1.65	1.75	1.85	0.065	0.069	0.073
b	0.22		0.38	0.009		0.015
b1	0.22	0.30	0.33	0.009	0.012	0.013
c	0.09		0.25	0.004		0.010
c1	0.09	0.15	0.21	0.004	0.006	0.008
D	9.9	10.2	10.5	0.390	0.402	0.413
E	7.40	7.80	8.20	0.291	0.307	0.323
E1	5.00	5.30	5.60	0.197	0.209	0.220
e	0.65 BSC			0.0256 BSC		
L	0.55	0.75	0.95	0.021	0.030	0.037
L1	0.25 REF.			0.050 REF.		
R1	0.09			0.004		
θ	0°	4°	8°	0°	4°	8°

6.2. Small Size Package (Body Size 150 mil)

Following diagrams show the dimensions of the small size 28-pin SSOP package.

Measurements are in inches. Dimensions do not include mold flash and dambar protrusion; allowable mold flash is 0.010 inch.

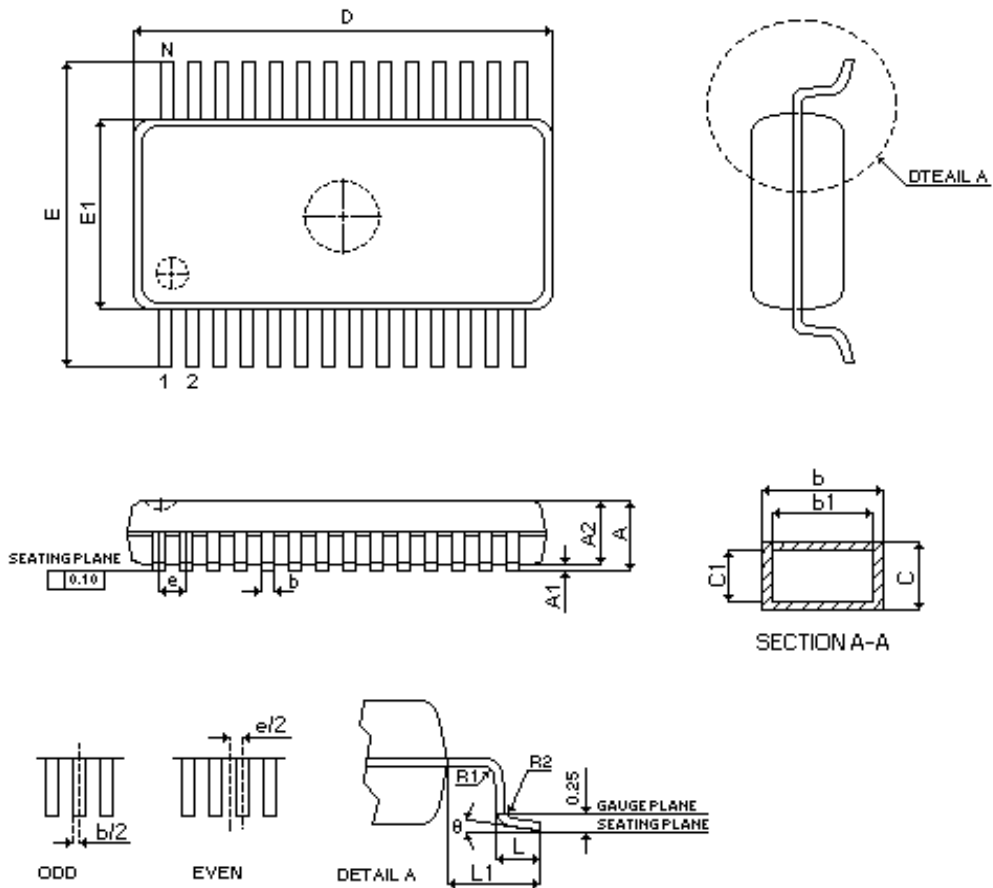

SYMBOL	COMMON DIMENSION MILLIMETERS			COMMON DIMENSION INCH		
	MIN.	NOM.	MAX.	MIN.	NOM.	MAX.
A	1.35	1.63	1.75	0.053	0.064	0.069
A1	0.10	0.15	0.25	0.004	0.006	0.010
A2			1.50			0.059
b	0.20		0.30	0.008		0.012
b1	0.20	0.25	0.27	0.008	0.010	0.011
c	0.18		0.25	0.007		0.010
D	9.8	9.91	10.01	0.386	0.390	0.394
E	5.79	5.99	6.20	0.0228	0.236	0.244
E1	3.81	3.91	3.99	0.150	0.154	0.157
e	0.635 BSC			0.025 BSC		
L	0.41	0.635	1.27	0.016	0.025	0.050
L1	0.838 REF.			0.033 REF.		
R1	0.20			0.008		
θ	0°		8°	0°		8°