

AZ100LVEL33

ECL/PECL ÷4 Divider

FEATURES

- Green / RoHS Compliant / Lead (Pb) Free package available
- Operating Range of 3.0V to 5.5V
- 470ps Propagation Delay
- 5.0+ GHz Toggle Frequency
- Internal Input Pulldown Resistors
- Direct Replacement for ON Semiconductor MC100EL33 & MC100LVEL33
- Transistor Count = 91 Devices
- IBIS Model Files Available on Arizona Microtek Web Site
- >2 kV HBM ESD Protection
- Additional ESD Data Available on Arizona Microtek Website

PACKAGE AVAILABILITY

PACKAGE	PART NUMBER	MARKING	NOTES
MLP 8 (2x2) Green / RoHS Compliant / Lead (Pb) Free	AZ100LVEL33NG	C3G <Date Code>	1,2
SOIC 8 Green / RoHS Compliant / Lead (Pb) Free	AZ100LVEL33DG	AZM100G LVEL33	1,2,3
MSOP 8 Green / RoHS Compliant / Lead (Pb) Free	AZ100LVEL33TG	AZHG LV33	1,2,3

- 1 Add R1 at end of part number for 7 inch (1K parts), R2 for 13 inch (2.5K parts) Tape & Reel.
- 2 Date code format: "Y" or "YY" for year followed by "WW" for week.
- 3 Date code "YWW" or "YYWW" on underside of part.

DESCRIPTION

The AZ100LVEL33 is an integrated ÷4 divider. The RESET pin is asynchronous and clears the output (Q Low, Q High) on the rising edge. Upon power-up, the internal flip-flop will be in a random logic state. RESET allows for the synchronization of multiple LVEL33's in a system.

The LVEL33 provides a V_{BB} output for single-end use or a DC bias reference for AC coupling to the device. For single-ended input applications, the V_{BB} reference should be connected to one side of the CLK/CLK differential input pair. The input signal is then fed to the other CLK/CLK input. The V_{BB} pin can support 1.0mA sink/source current. When used, the V_{BB} pin should be bypassed to ground via a 0.01 μ F capacitor.

NOTE: Specifications in the ECL/PECL tables are valid when thermal equilibrium is established.

PIN DESCRIPTION

PIN	FUNCTION
CLK, CLK	Clock Inputs
RESET	Asynchronous Reset
V_{BB}	Reference Voltage Output
Q, Q	Data Outputs
V_{CC}	Positive Supply
V_{EE}	Negative Supply

LOGIC DIAGRAM

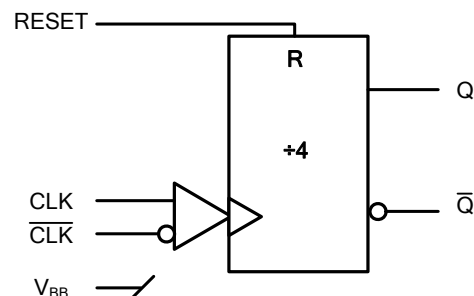

AZ100LEVEL33

Absolute Maximum Ratings are those values beyond which device life may be impaired.

Symbol	Characteristic	Rating	Unit
V _{CC}	PECL Power Supply (V _{EE} = 0V)	0 to +8.0	Vdc
V _I	PECL Input Voltage (V _{EE} = 0V)	0 to +6.0	Vdc
V _{EE}	ECL Power Supply (V _{CC} = 0V)	-8.0 to 0	Vdc
V _I	ECL Input Voltage (V _{CC} = 0V)	-6.0 to 0	Vdc
I _{OUT}	Output Current --- Continuous --- Surge	50 100	mA
T _A	Operating Temperature Range	-40 to +85	°C
T _{STG}	Storage Temperature Range	-65 to +150	°C

ECL DC Characteristics (V_{EE} = -3.0V to -5.5V, V_{CC} = GND)

Symbol	Characteristic	-40°C			0°C			25°C			85°C			Unit
		Min	Typ	Max	Min	Typ	Max	Min	Typ	Max	Min	Typ	Max	
V _{OH}	Output HIGH Voltage ¹	-1085	-1005	-880	-1025	-955	-880	-1025	-955	-880	-1025	-955	-880	mV
V _{OL}	Output LOW Voltage ¹	-1830	-1695	-1555	-1810	-1705	-1620	-1810	-1705	-1620	-1810	-1705	-1620	mV
V _{IH}	Input HIGH Voltage	-1165		-880	-1165		-880	-1165		-880	-1165		-880	mV
V _{IL}	Input LOW Voltage	-1810		-1475	-1810		-1475	-1810		-1475	-1810		-1475	mV
V _{BB}	Reference Voltage	-1380		-1260	-1380		-1260	-1380		-1260	-1380		-1260	mV
I _{IH}	Input HIGH Current			150			150			150			150	μA
I _{IL}	Input LOW Current CLK, CLK RESET	-150 0.5			-150 0.5			-150 0.5			-150 0.5			μA
I _{EE}	Power Supply Current		27	33		27	33		27	33		31	37	mA

1. Each output is terminated through a 50Ω resistor to V_{CC} - 2V.

LVPECL DC Characteristics (V_{EE} = GND, V_{CC} = +3.3V)

Symbol	Characteristic	-40°C			0°C			25°C			85°C			Unit
		Min	Typ	Max	Min	Typ	Max	Min	Typ	Max	Min	Typ	Max	
V _{OH}	Output HIGH Voltage ^{1,2}	2215	2295	2420	2275	2345	2420	2275	2345	2420	2275	2345	2420	mV
V _{OL}	Output LOW Voltage ^{1,2}	1470	1605	1745	1490	1595	1680	1490	1595	1680	1490	1595	1680	mV
V _{IH}	Input HIGH Voltage ¹	2135		2420	2135		2420	2135		2420	2135		2420	mV
V _{IL}	Input LOW Voltage ¹	1490		1825	1490		1825	1490		1825	1490		1825	mV
V _{BB}	Reference Voltage ¹	1920		2040	1920		2040	1920		2040	1920		2040	mV
I _{IH}	Input HIGH Current			150			150			150			150	μA
I _{IL}	Input LOW Current CLK, CLK RESET	-150 0.5			-150 0.5			-150 0.5			-150 0.5			μA
I _{EE}	Power Supply Current		27	33		27	33		27	33		31	37	mA

1. For supply voltages other than 3.3V, use the ECL table values and ADD supply voltage value.

2. Each output is terminated through a 50Ω resistor to V_{CC} - 2V.

PECL DC Characteristics (V_{EE} = GND, V_{CC} = +5.0V)

Symbol	Characteristic	-40°C			0°C			25°C			85°C			Unit
		Min	Typ	Max	Min	Typ	Max	Min	Typ	Max	Min	Typ	Max	
V _{OH}	Output HIGH Voltage ^{1,2}	3915	3995	4120	3975	4045	4120	3975	4045	4120	3975	4045	4120	mV
V _{OL}	Output LOW Voltage ^{1,2}	3170	3305	3445	3190	3295	3380	3190	3295	3380	3190	3295	3380	mV
V _{IH}	Input HIGH Voltage ¹	3835		4120	3835		4120	3835		4120	3835		4120	mV
V _{IL}	Input LOW Voltage ¹	3190		3525	3190		3525	3190		3525	3190		3525	mV
V _{BB}	Reference Voltage ¹	3620		3740	3620		3740	3620		3740	3620		3740	mV
I _{IH}	Input HIGH Current			150			150			150			150	μA
I _{IL}	Input LOW Current CLK, CLK RESET	-150 0.5			-150 0.5			-150 0.5			-150 0.5			μA
I _{EE}	Power Supply Current		27	33		27	33		27	33		31	37	mA

1. For supply voltages other than 5.0V, use the ECL table values and ADD supply voltage value.

2. Each output is terminated through a 50Ω resistor to V_{CC} - 2V.

AZ100LEVEL33

AC Characteristics ($V_{EE} = -3.0V$ to $-5.5V$; $V_{CC} = GND$ or $V_{EE} = GND$; $V_{CC} = +3.0V$ to $+5.5V$)

Symbol	Characteristic	-40°C			0°C			25°C			85°C			Unit
		Min	Typ	Max	Min	Typ	Max	Min	Typ	Max	Min	Typ	Max	
f_{max}	Maximum Toggle Frequency	4.2			4.2			4.2			4.2			GHz
t_{PLH}/t_{PHL}	Propagation Delay CLK, CLK to Q/Q RESET to Q/Q	360 310	450 460	540 610	320 340	460 460	550 580	380 360	470 460	560 560	400 380	490 480	580 580	ps
t_{RR}	Reset Recovery	300			300			300			300			ps
t_{skew}	Within-Device Skew			20			20			20			20	ps
$V_{PP}(AC)$	Input Swing ¹	150		1000	150		1000	150		1000	150		1000	mV
V_{CMR}	Common Mode Range ² $V_{pp} < 500mV$ $V_{pp} \geq 500mV$	$V_{EE} +$ 1.2 1.4		$V_{CC} -$ 0.4 0.4	$V_{EE} +$ 1.1 1.3		$V_{CC} -$ 0.4 0.4	$V_{EE} +$ 1.1 1.3		$V_{CC} -$ 0.4 0.4	$V_{EE} +$ 1.1 1.3		$V_{CC} -$ 0.4 0.4	V
t_r/t_f	Output Rise/Fall Times Q/Q (20% - 80%)	100		260	100		260	100		260	100		260	ps

- V_{PP} is the peak-to-peak differential input swing for which AC parameters are guaranteed.
- V_{CMR} is defined as the range within which the V_{IH} level may vary, with the device still meeting the propagation delay specification. The V_{IL} level must be such that V_{PP} is within the differential input swing range specified.

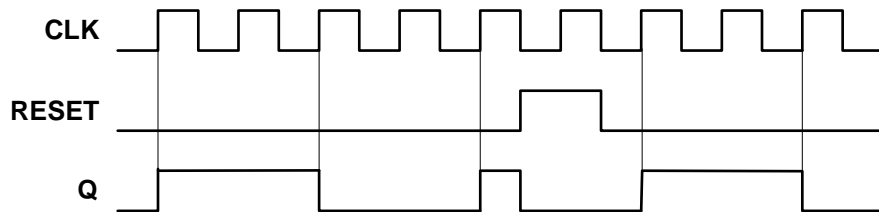
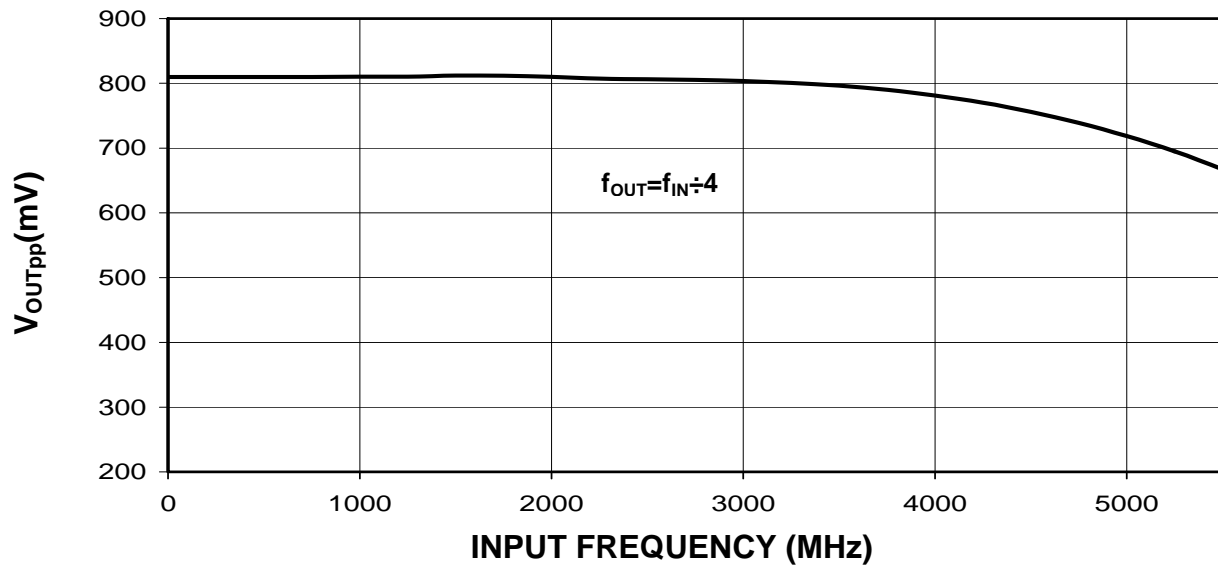

Figure 1. Timing Diagram

Typical Large Signal Output Swing, Q/Q



Measured with 750mv D input, Q/Q each terminated to $V_{CC}-2V$ via 50Ω resistors.

**PACKAGE PINOUTS
TOP VIEW**

AZ100LVEL33N

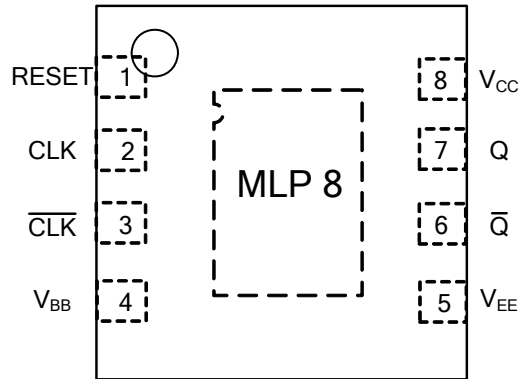

Bottom Center Pad may be left open or tied to V_{EE} .

**AZ100LVEL33D
AZ100LVEL33T**

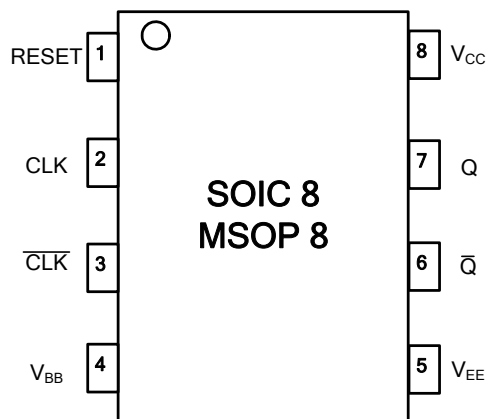

**PACKAGE DIAGRAM
SOIC 8**

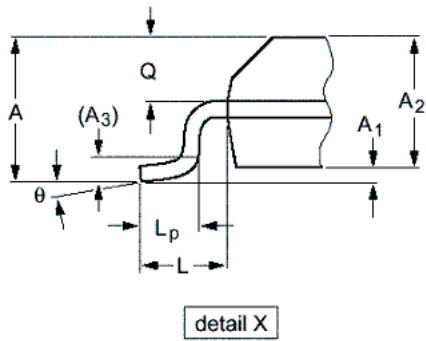
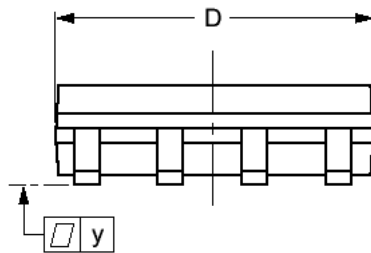
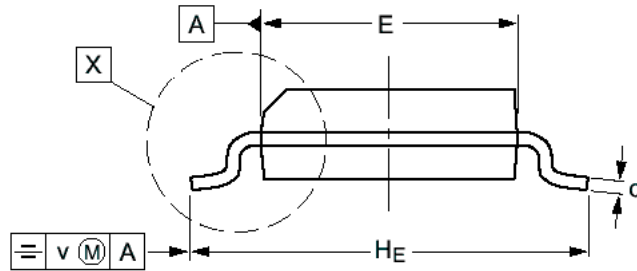
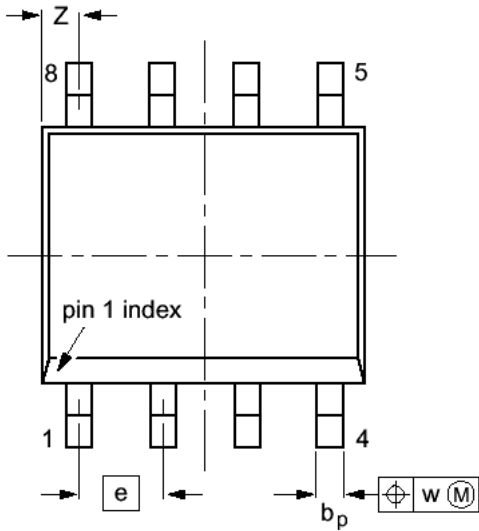

NOTES:

1. DIMENSIONS D AND E DO NOT INCLUDE MOLD PROTRUSION.
2. MAXIMUM MOLD PROTRUSION FOR D IS 0.15mm.
3. MAXIMUM MOLD PROTRUSION FOR E IS 0.25mm.

DIM	MILLIMETERS		INCHES	
	MIN	MAX	MIN	MAX
A		1.75		0.069
A ₁	0.10	0.25	0.004	0.010
A ₂	1.25	1.45	0.049	0.057
A ₃	0.25		0.01	
b _p	0.36	0.49	0.014	0.019
c	0.19	0.25	0.0075	0.0100
D	4.8	5.0	0.19	0.20
E	3.8	4.0	0.15	0.16
e	1.27		0.050	
H _E	5.80	6.20	0.228	0.244
L	1.05		0.041	
L _p	0.40	1.00	0.016	0.039
Q	0.60	0.70	0.024	0.028
v	0.25		0.01	
w	0.25		0.01	
y	0.10		0.004	
Z	0.30	0.70	0.012	0.028
θ	0°	8°	0°	8°

**PACKAGE DIAGRAM
MSOP 8**

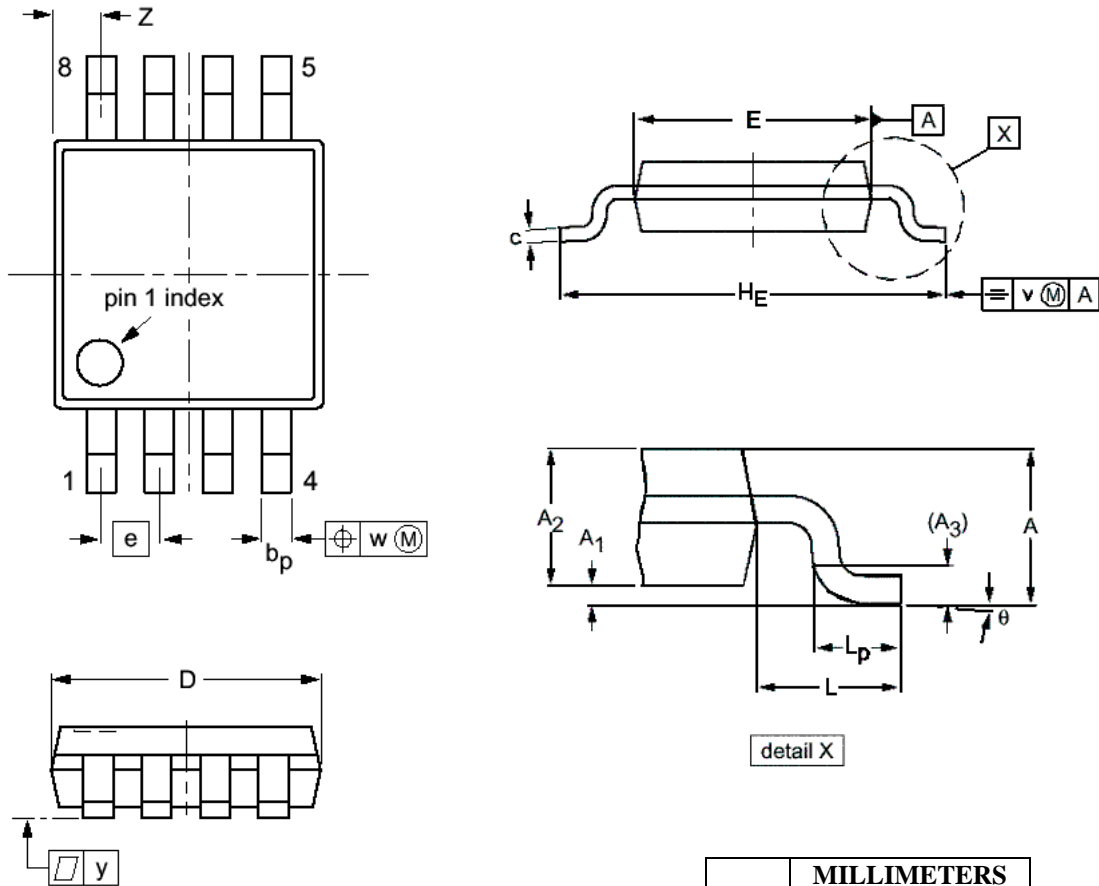

- NOTES:
1. DIMENSIONS D AND E DO NOT INCLUDE MOLD PROTRUSION.
 2. MAXIMUM MOLD PROTRUSION FOR D IS 0.15mm.
 3. MAXIMUM MOLD PROTRUSION FOR E IS 0.25mm.

DIM	MILLIMETERS	
	MIN	MAX
A		1.10
A ₁	0.05	0.15
A ₂	0.80	0.95
A ₃	0.25	
b _p	0.25	0.45
c	0.15	0.28
D	2.90	3.10
E	2.90	3.10
e	0.65	
H _E	4.70	5.10
L	0.94	
L _p	0.40	0.70
v	0.10	
w	0.10	
y	0.10	
Z	0.35	0.70
θ	0°	6°

PACKAGE DIAGRAM
MLP 8 2x2mm

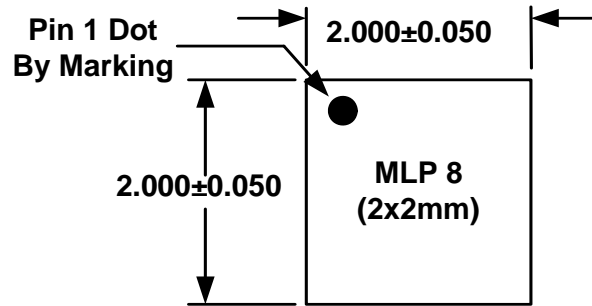

TOP VIEW

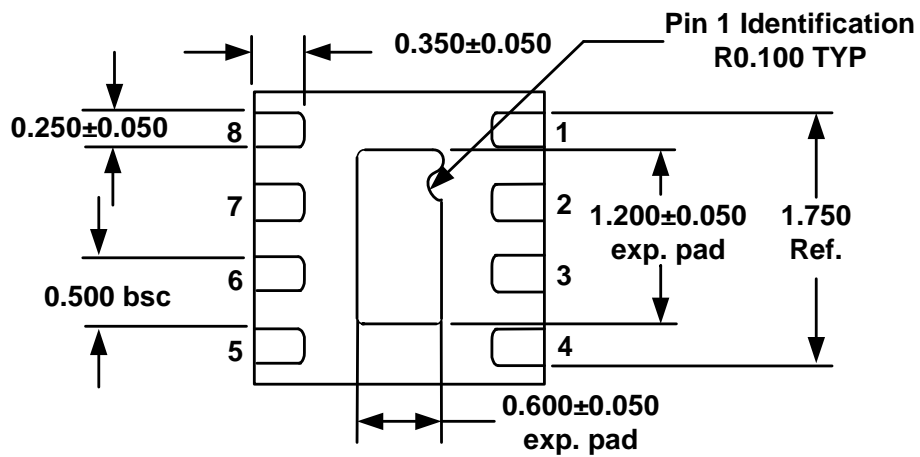

BOTTOM VIEW

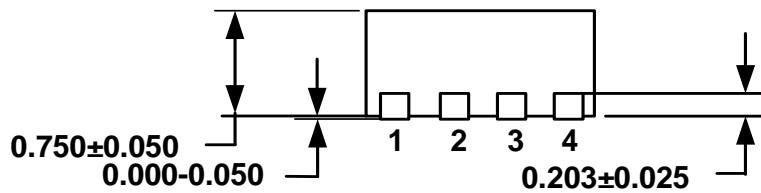

SIDE VIEW

Note: All dimensions are in mm

Arizona Microtek, Inc. reserves the right to change circuitry and specifications at any time without prior notice. Arizona Microtek, Inc. makes no warranty, representation or guarantee regarding the suitability of its products for any particular purpose, nor does Arizona Microtek, Inc. assume any liability arising out of the application or use of any product or circuit and specifically disclaims any and all liability, including without limitation special, consequential or incidental damages. Arizona Microtek, Inc. does not convey any license rights nor the rights of others. Arizona Microtek, Inc. products are not designed, intended or authorized for use as components in systems intended to support or sustain life, or for any other application in which the failure of the Arizona Microtek, Inc. product could create a situation where personal injury or death may occur. Should Buyer purchase or use Arizona Microtek, Inc. products for any such unintended or unauthorized application, Buyer shall indemnify and hold Arizona Microtek, Inc. and its officers, employees, subsidiaries, affiliates, and distributors harmless against all claims, costs, damages, and expenses, and reasonable attorney fees arising out of, directly or indirectly, any claim of personal injury or death associated with such unintended or unauthorized use, even if such claim alleges that Arizona Microtek, Inc. was negligent regarding the design or manufacture of the part.