

# AM radio / FM IF stereo system IC

## BA1451F

The BA1451F is a tuner system IC for electronic tuning for AM radios, FM IF, and MPX. It has been developed for HiFi component applications.

The MPX VCO circuit requires no adjustment, which will enable a reduction in the number of production line processes. In particular, the laser lock technique used in the VCO means that no external adjustment is required.

### ●Applications

Synthesized tuner for HiFi components.

### ●Features

- 1) Built-in AM monaural radio, FM IF amplifier/detector, and FM stereo demodulator.
- 2) DTS (both SD and IF count) compatible.
- 3) Built-in reference voltage power supply provides good shortwave band frequency stability.
- 4) Good FM stability.
- 5) The FM MPX VCO uses laser locking making adjustment and external components unnecessary.
- 6) Built-in forced monaural operation function for MPX (VCO stops, and LED goes off).
- 7) Low cutoff of audio is possible to improve AM fidelity.
- 8) MPX VCO stops in AM mode.
- 9) Audio muting is possible when an IF request is made.

### ●Block diagram

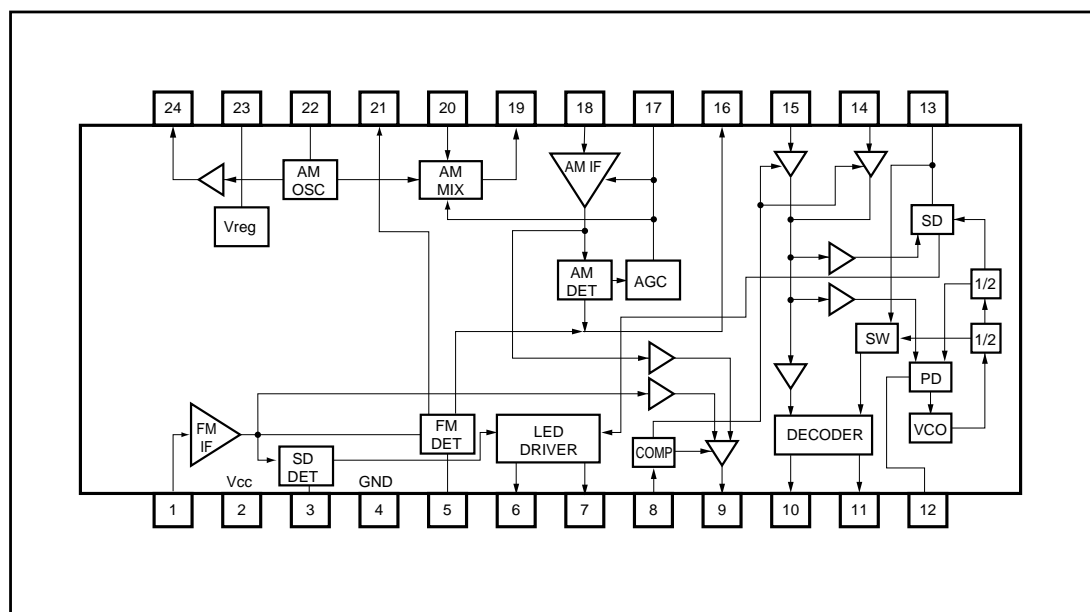

## Audio ICs

## ●Absolute maximum ratings

Parameter	Symbol	Limits	Unit
Power supply voltage	$V_{CC}$	9.0	V
Power dissipation	$P_d$	450*1	mW
Operating temperature	$T_{opr}$	-25~+75	°C
Storage temperature	$T_{stg}$	-55~+125	°C

\*1 Reduced by 4.5mW for each increase in  $T_a$  of 1°C over 25°C.

●Recommended operating conditions ( $T_a=25^\circ\text{C}$ )

Parameter	Symbol	Min.	Typ.	Max.	Unit
Power supply voltage	$V_{CC}$	3.8	5.0	8.0	V

## ●Input and output circuits

Pin No.	Function	Internal circuit	Quiescent voltage (V)	
			FM	AM
1	FM IF amplifier input Connect to an FM ceramic filter.		2.1	2.1
2	$V_{CC}$		5.0	5.0
3	FM tuning ON level adjustment Connect a resistor from this pin to GND to set the required ON level for the tuning indicator.		0.25	0
4	GND		0	0
5	FM discriminator Connect to the discriminator coil.		5.0	5.0
6	Tuning indicator Connect to a tuning indicator display device (eg. LED)		-	-
7	Stereo indicator Connect to a stereo indicator display device (eg. LED)		-	-

Audio ICs

Pin No.	Function	Internal circuit	Quiescent pin voltage (V)	
			FM	AM
8	<ul style="list-style-type: none"> <li>IF request Output the IF signal to pin9 excess of 4.0V. Stops the IF signal at equal to or less than 3.0V.</li> <li>MUTE Apply to muting excess of 2.0V. Off the muting at equal to or less than 1.0V.</li> </ul>		0	0
9	<p>IF output Output for the IF signal.</p>		4.2	4.2
10	R-channel output		1.5	1.5
11	L-channel output		1.5	1.5
12	<ul style="list-style-type: none"> <li>PLL filter Connect to a lag/lead filter.</li> <li>AM / FM band switch AM band when connected to GND.</li> </ul>		2.1	0
13	<ul style="list-style-type: none"> <li>Forced monaural Forced monaural operation connecting to get a resistor to mediate. (Recommended value : 10kΩ to ground.)</li> <li>Pilot filter Connect to a capacitor.</li> </ul>		2.1	2.1

Audio ICs

Pin No.	Function	Internal circuit	Quiescent pin voltage (V)	
			FM	AM
14	MPX input Input the FM detector output .		2.1	2.1
15	MPX input Input the AM detector output after low cut.		2.1	2.1
16	AM/FM detector output Connect to the following stage MPX and FM low pass filter.		2.1	2.1
17	AM AGC Connect to a capacitor.		0	0
18	AM IF input Connect to an AM ceramic filter.		5.0	5.0
19	AM mixer output Connect to primary side of AM IFT.		5.0	5.0
20	AM antenna Connect to AM antenna.		2.1	2.1

## Audio ICs

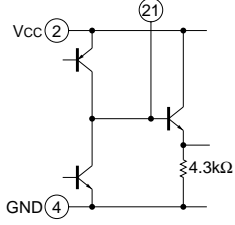
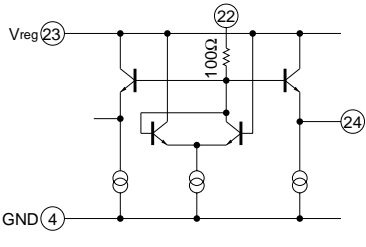
Pin No.	Function	Internal circuit	Quiescent pin voltage (V)	
			FM	AM
21	FM detector bandwidth adjustment Connect a resistor from this pin to the reference voltage supply to set the required detector bandwidth.		2.1	2.1
23	Reference voltage supply Connected to a capacitor.	—	2.1	2.1
22	AM local oscillator Connect to the AM OSC circuit.		2.1	2.1
24	AM local oscillator output AM OSC output.		1.7	1.4

● **Electrical characteristics** (Unless otherwise specified,  $T_a=25^\circ\text{C}$  and  $V_{CC}=5\text{V}$ )

FM IF MPX signal source :  $f_{IN}=10.7\text{MHz}$ , modulation 1kHz, 75kHzdev (100%)

19kHz 7.5kHzdev (10%)

AM :  $f_{IN}=1000\text{kHz}$ , modulation 1kHz 30%

Parameter	Symbol	Min.	Typ.	Max.	Unit	Conditions
Quiescent current FM	$I_{Q(FM)}$	13	21	29	mA	No input
Quiescent current AM	$I_{Q(AM)}$	11	19	27	mA	No input
<FM IF MPX>						
Detector output voltage	$V_O$	340	480	670	mVrms	$V_{IN}=100\text{dB}\mu\text{V}$ , mono
-3dB limiting sensitivity	L.S	34	37	40	$\text{dB}\mu\text{V}$	mono
Signal-to-noise ratio	S / N	72	80	-	dB	$V_{IN}=100\text{dB}\mu\text{V}$ , mono
Channel balance	C.B	-2	0	+2	dB	$V_{IN}=100\text{dB}\mu\text{V}$ , mono
AM suppression ratio	AMR	45	55	-	dB	AM : $V_{IN}=60\text{dB}\mu\text{V}$ , mod=30%, 400Hz
Channel separation	SEP	35	45	-	dB	$V_{IN}=100\text{dB}\mu\text{V}$ , main
Total harmonic distortion	THD	-	0.5	1.6	%	$V_{IN}=100\text{dB}\mu\text{V}$ , main
Station detector sensitivity	$SD_s$	34	39	44	$\text{dB}\mu\text{V}$	Input for pin 6 current $\geq 1\text{mA}$
Station detector bandwidth	$SD_{SW}$	70	100	150	kHz	$V_{IN}=100\text{dB}\mu\text{V}$ , mono
IF OUT output voltage	$V_{IF}$	300	400	530	mV <sub>P-P</sub>	IF request ON
<AM>						
Detector output voltage	$V_O$	70	90	120	mVrms	$V_{IN}=68\text{dB}\mu\text{V}$
Usable sensitivity	Q.S	22	25	28	$\text{dB}\mu\text{V}$	Input for S / N = 20dB
Signal-to-noise ratio	S / N	42	52	-	dB	$V_{IN}=68\text{dB}\mu\text{V}$
Total harmonic distortion	THD	-	0.6	1.8	%	$V_{IN}=68\text{dB}\mu\text{V}$
Station detector sensitivity	$SD_s$	21	26	31	$\text{dB}\mu\text{V}$	Input for pin 6 current $\geq 1\text{mA}$
IF OUT output voltage	$V_{IF}$	300	400	530	mV <sub>P-P</sub>	IF request ON
Local buffer output voltage	$V_{O\text{Buff}}$	140	200	280	mVrms	

● Test circuit

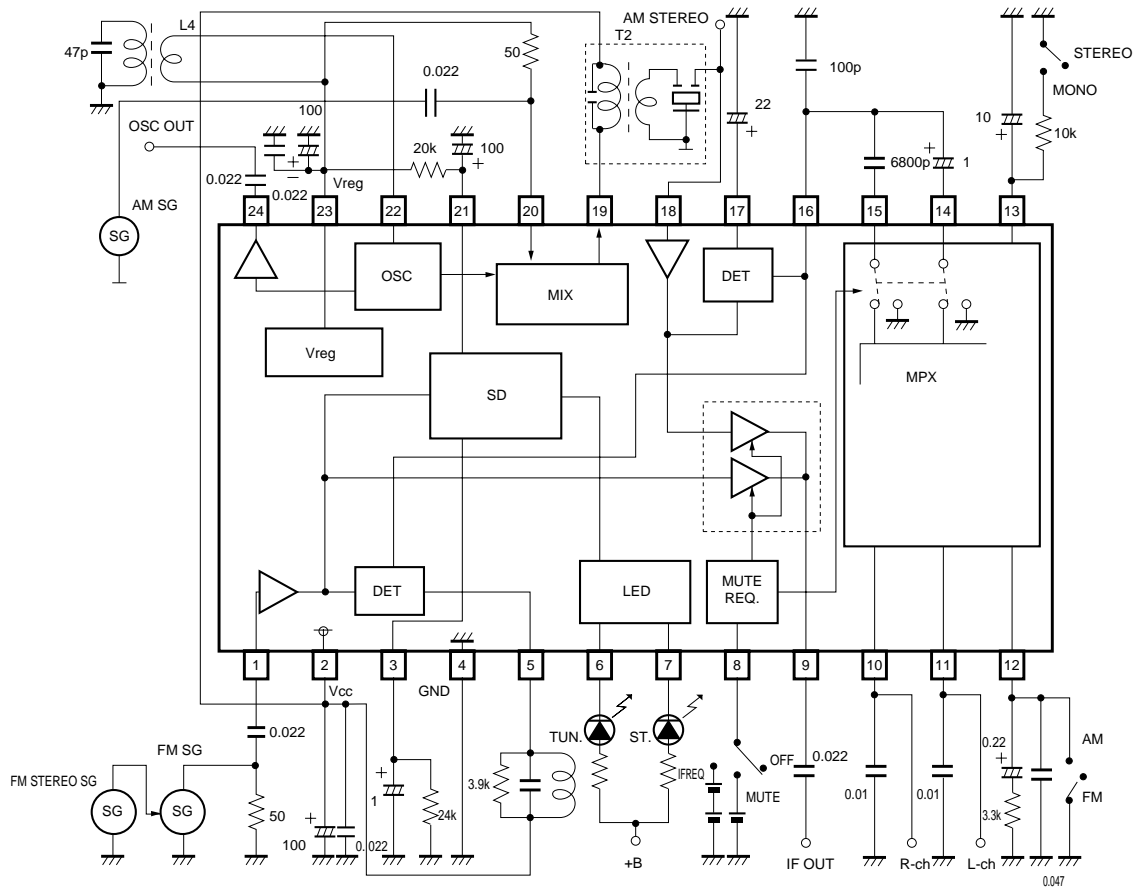

L4 : AM OSC  
 T2 : AM IFT  
 CD1 : FM DISCRIMINATOR COIL

Sumida  
 Toko  
 Toko  
 Sumida  
 Toko

2157-JPS-029  
 A7BRS-12445X  
 CFMA-258  
 0236-JPS-101  
 A119ACS-19197N

Units : R [ $\Omega$ ]  
 C [ $\mu$ F]

Fig. 1

●Application example

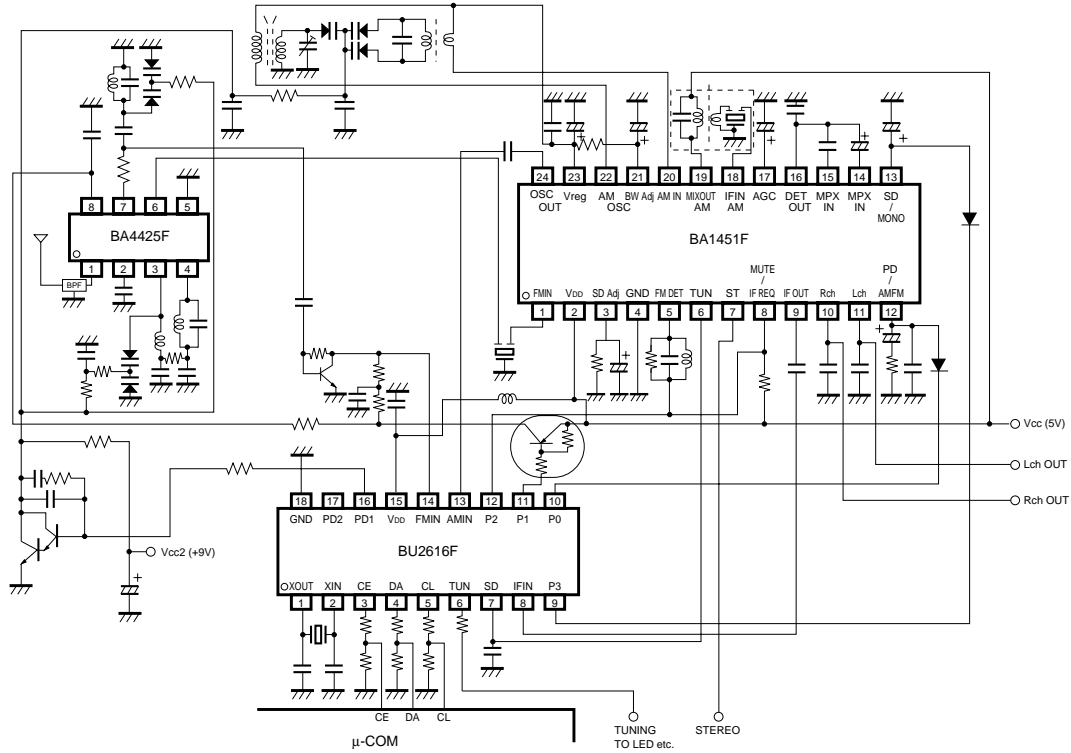

Fig. 2

●Electrical characteristic curves

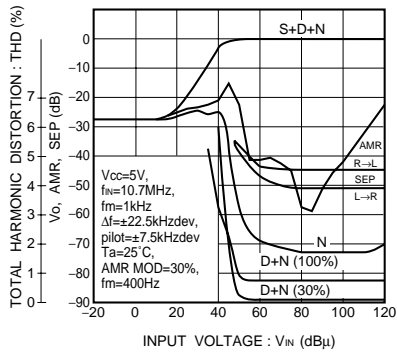

Fig.3 FM input / output characteristics

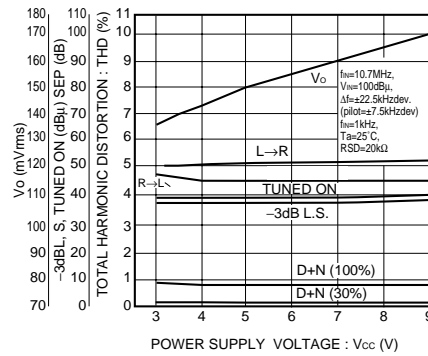

Fig.4 FM characteristics vs. power supply voltage

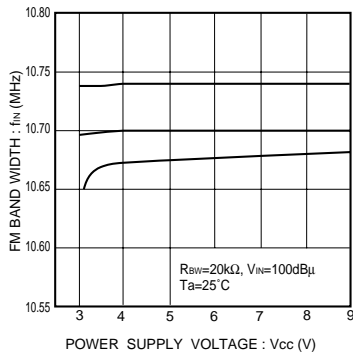

Fig.5 FM bandwidth vs. power supply voltage

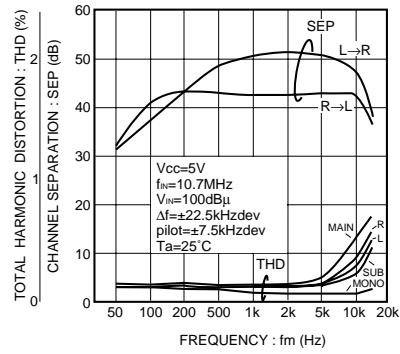

Fig.6 Channel separation and THD vs. frequency

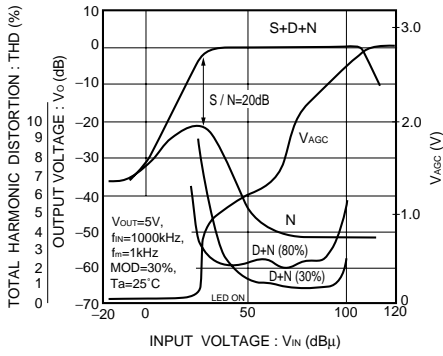

Fig.7 AM input / output characteristics

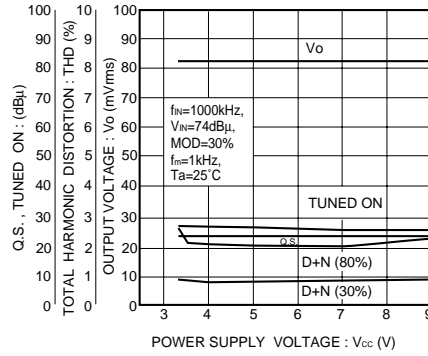

Fig.8 AM characteristics vs. power supply voltage

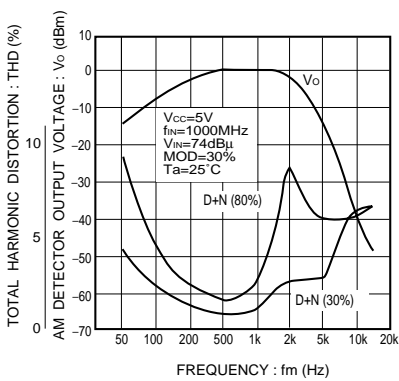
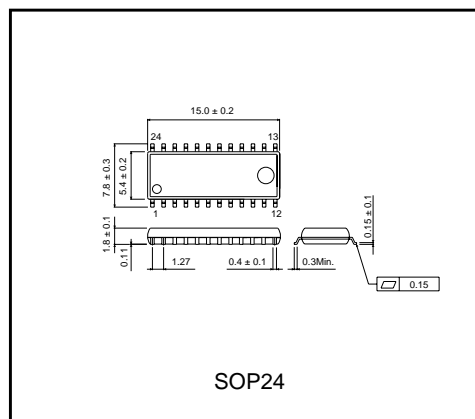

Fig.9 AM detector output and THD vs. frequency

● External dimensions (Units : mm)



SOP24